



The general purpose Hardware Security Module

The SecurityServer Se Gen2 from Utimaco secures cryptographic key material for servers and applications. It includes integration software that supports the industry standards (e.g. PKCS#11, Microsoft CSP/CNG, JCE, ...) which are used in most application scenarios, e.g. Enterprise PKI applications, database encryption, etc. The SecurityServer Se Gen2 is available as PCIe embedded card or as network attached appliance.

Low operational costs

- Highest performance at an attractive price
- Inexpensive starter models for standard industry applications
- Extensive remote administration
- Efficient key management and firmware updates via remote access
- Automation of remote diagnosis through a network management system using SNMP protocol
- Software simulator for evaluation and integration testing

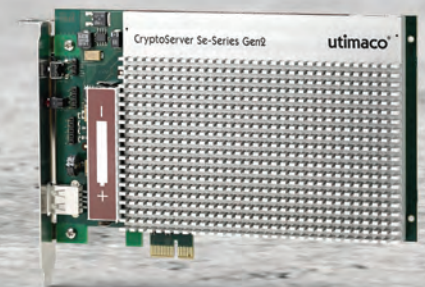

Contact

hsm@utimaco.com
hsm.utimaco.com

EMEA

Utimaco IS GmbH – Headquarter
Germanusstraße 4
52080 Aachen, Germany
Phone + 49 241 1696 200

Americas

Utimaco Inc.
910 E Hamilton Ave., Suite 150
Campbell, CA 95008, USA
Phone +1 844 UTIMACO

APAC

Utimaco IS GmbH – Office APAC
One Raffles Quay, North Tower, Level 25
Singapore 048583
Phone +65 6622 5347

Capabilities

- Secure key storage and processing
- Extensive key management
- Key storage inside HSM or as encrypted key files
- Smartcard for strong authentication
- “n out of m” authentication
- Separation of duties
- Remote management
- Software simulator for evaluation and integration testing
- Supported OS: Windows and Linux
- Multiple integrations with PKI applications, database encryption, etc.
- All capabilities included in product price

Security, safety, environmental compliance

- FIPS 140-2 Level 3
- CE, FCC Class B
- UL, IEC/EN 60950-1
- CB certificate
- RoHS II, WEEE

Physical specifications PCIe card

- Half length, full height single lane PCI Express card
- Supports PCIe 1.1, PCIe 2.0 and PCIe 3.0 slots
- Operating voltage: 3.3V
- Battery 3 V, Lithium, Ø 12 mm, length 600 mm, FDK CR 12600 SE or VARTA CR2NP
- USB interface
- Operating temperature: +10°C to +45°C (+50°F to +113°F)
- Storage temperature: -10°C to +55°C (+14°F to +131°F)
- Relative humidity: 10% to 95% non-condensing
- MTBF 360,000 hours at 25°C / 77°F

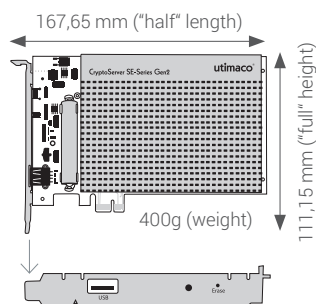

Available models and performance

Se12		Se52		Se500		Se1500	
PCIe	LAN	PCIe	LAN	PCIe	LAN	PCIe	LAN

RSA signature generation (tps*)

2048 Bit	16	16	80	75	690	580	960	780
4096 Bit	2	2	11	11	100	90	160	150

RSA bulk signature generation (tps*)

2048 Bit	16	16	85	80	2200	2100	3400	3200
4096 Bit	2	2	11	11	220	220	360	360

Elliptic Curve signature generation (tps*)

224 Bit	150	140	1000	880	1300	1040	1900	1400
384 Bit	50	50	450	390	950	790	1400	1100

Elliptic Curve bulk signature generation (tps*)

224 Bit	160	160	1400	1300	1800	1700	3500	3100
384 Bit	54	54	490	490	1300	1200	2400	2200

Cryptographic Algorithms

- RSA, DSA, ECDSA with NIST and Brainpool curves
- DH, ECDH with NIST and Brainpool curves
- AES, Triple-DES, DES
- MAC, CMAC, HMAC
- SHA-1, SHA2-Family, SHA3 (as from SecurityServer 4.10), RIPEMD
- Hash-based Deterministic Random Number Generator (DRNG)
- True Random Number Generator (TRNG acc. AIS31 class PTG.2)
- All algorithms included in product price

Application Programming Interfaces (APIs)

- PKCS#11
- Java Cryptography Extension (JCE)
- Microsoft Crypto API (CSP), Cryptography Next Generation (CNG) and SQL Extensible Key Management (SQLEKM)
- Cryptographic eXtended services Interface (CXI)
Utimaco's high performance interface guarantees easy integration of cryptographic functionality into client applications

Physical specifications network appliance

- 19" 2U form factor
- Redundant field-replaceable power supply: 90~264 V, 47~63 Hertz AC, 2 x 320 W
- Power consumption typically: 75 W / 85 VA, max. 90 W / 100 VA
- Heat dissipation: max. 307 BTU/h
- 2 RJ45 1 Gb/s network interfaces
- Operating temperature: +10°C to +50°C (+50°F to +122°F)
- Storage temperature: -10°C to +55°C (+14°F to +131°F)
- Relative humidity: 10% to 95% non-condensing
- MTBF 90,000 hours at 25°C / 77°F

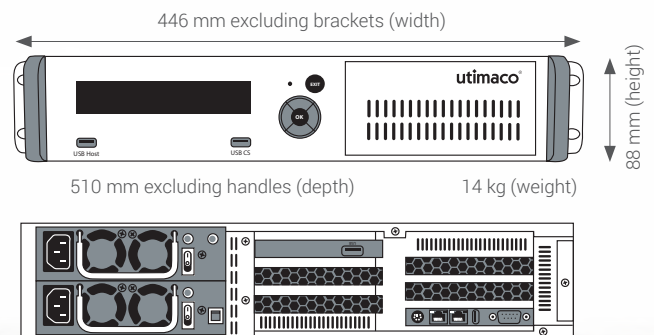

* Transactions per second