

Anexa 36, Densitometru McFarland

DEN-1B, Densitometer, Biosan, Letonia

Parametri solicitati	Parametri oferiti
"Dispozitiv pentru măsurarea turbidității suspensiilor prin metodă optică Domeniu de măsurare 0.1 - 4 McF Acuratețea: $\leq 5\%$ la 2 McF Volum minim măsurat: ≤ 2 ml Posibilitate funcționare de la rețea sau baterii/acumulatori Afișare date pe ecran LCD Diametru eprubete acceptate: 16 mm Accesorii livrate: baterii/acumulator,, cablu alimentare, bloc alimentare(în caz de alimentare de la sursă externă), set standarde pentru calibrare (în cazul necesității calibrării periodice)."	Dispozitiv pentru măsurarea turbidității suspensiilor prin metodă optică Domeniu de măsurare 0.00 - 15 McF Acuratețea: 3% pentru interbalul 0-6 McF Volum minim măsurat: 2 ml Posibilitate funcționare de la rețea sau baterii/acumulatori Afișare date pe ecran LCD Diametru eprubete acceptate: 16 mm Accesorii livrate: baterii/acumulator,, cablu alimentare si bloc alimentare(pentru alimentare de la sursă externă), 1x set standarde pentru calibrare (în cazul necesității calibrării periodice). Model CKG16 for glass tubes with diameter 16 mm, set of 0.5; 1.0; 2.0; 3.0; 4.0 McFarland Turbidity Standards (latex particles). Cat.Nr.: BS-050102-BK

DEN-1B, Densitometer (suspension turbidity detector)

DESCRIPTION

Densitometer is designed for measurement of cell suspension's turbidity in the range of 0.0–6.0 McFarland units (0 – 180×10^7 cells/ml).

Densitometers provide the opportunity to measure solution turbidity in a wider range (up to 15.0 McFarland units) however, it is necessary to remember that in this case the standard deviation values increase.

A densitometer is used for measurement of cell concentration (bacterial, yeast cells) during fermentation process, determination of microorganism sensitivity to antibiotics, microorganism identification using various test-systems, for measurement of absorption at the definite wavelength, as well as for quantitative estimation of concentration of colour solution, absorbing green light.

The operation principle is based on measurement of optical density with digital presentation of results in McFarland units. The unit is calibrated at the factory (for operation with 16 mm diameter glass tubes) and keeps calibration without power supply. However, if necessary it is possible to calibrate the unit by 2–6 points in 0.0–6.0 McFarland unit range. We recommend to use Biosan standards to ensure full reliability, but it is acceptable to use other commercial as well as self prepared standards (e.g. BaSO₄). Possibility to restore factory calibration settings.

Following calibration kits are available on request:

- **CKG16** for glass tubes with diameter 16 mm, set of 0.5; 1.0; 2.0; 3.0; 4.0 McFarland Turbidity Standards (latex particles).
Cat.Nr.: BS-050102-BK
- Calibration kit for glass tubes with diameter 18 mm, set of 0.5; 1.0; 2.0; 3.0; 4.0; 5.0 McFarland Turbidity Standards (BaSO₄).
Cat.Nr.: 70900
- Calibration kit for glass tubes with diameter 12 mm, set of 0.0 (blank); 0.5; 2.0; 3.0 McFarland Turbidity Standards (latex particles).
Cat.Nr.: 21255

Two versions of the product are available:

1. **DEN-1** powered from external energy supply;
2. **DEN-1B** powered both from external energy supply and from batteries (AA).



CAT. NUMBER

BS-050104-AAF	230VAC 50/60Hz Euro plug
BS-050104-AAK	100-240VAC 50/60Hz Multi plug (EU, UK, AU, US)
BS-050104-AK	IQ OQ document
BS-050104-BK	PQ document

SPECIFICATIONS

Measurement range	0.00–15.00 McF
Display resolution	0.01 McF
Light source	LED
Measurement wavelength (λ)	$\lambda = 565 \pm 15$ nm
Accuracy (0.0–6.0 McF)	$\pm 3\%$
Measurement time	1 s
Sample volume	not less than 2 ml
Tube external diameter	12 mm, 16 mm (using A-12, A-16 adapter) or 18 mm (without adapter)
Possibility to restore factory calibration settings	+
Display	LCD
Independent power supply	3 × AA batteries
Overall dimensions (W×D×H)	165 × 115 × 75 mm
Weight	0.7 kg
Input current/power consumption	12 V, 7 mA / 0.1 W
External power supply	Input AC 100–240 V, 50/60 Hz; Output DC 12 V
Standard set	External power supply, A-16 and 3 × AA batteries

ACCESSORIES



Glass test tubes 16mm
BS-050102-MK

Glass Test Tubes 16x100mm, high borosilicate, PP Cap with silicone pad.
Packing - 100 pcs/box



CKG16
BS-050102-BK
Calibration kit

CKG16 for glass tubes with diameter 16 mm, set of 0.5; 1.0; 2.0; 3.0; 4.0 McFarland Turbidity Standards (latex particles).

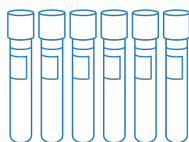

Calibration kit
70900
d18mm

McFarland Turbidity Standards, $\varnothing 18$ mm

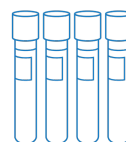

Calibration kit
21255
d12mm

McFarland Turbidity Standards, $\varnothing 12$ mm



Glass test tubes 18mm
BS-050102-NK

Glass Test Tubes 18x100mm, high borosilicate, PP Cap with silicone pad.
Packing - 100 pcs/box



A-12
BS-050102-1K
adapter

A-12, adapter for work with tubes which are 12 mm in external diameter.

EU Declaration of Conformity

Unit type Densitometers

Models DEN-1, DEN-1B, DEN-600

Serial number 14 digits styled XXXXXXYYMMZZZZ, where XXXXXX is model code, YY and MM – year and month of production, ZZZZ – unit number.

Manufacturer SIA BIOSAN
Latvia, LV-1067, Riga, Ratsupites str. 7/2

The objects of the declaration described above is in conformity with the following relevant Union harmonization legislations:

LVD 2014/35/EU	LVS EN 61010-1:2011 Safety requirements for electrical equipment for measurement, control, and laboratory use. General requirements.
EMC 2014/30/EU	LVS EN 61326-1:2013 Electrical equipment for measurement, control and laboratory use. EMC requirements. General requirements.
RoHS3 2015/863/EU	Directive on the restriction of the use of certain hazardous substances in electrical and electronic equipment.
WEEE 2012/19/EU	Directive on waste electrical and electronic equipment.

I declare that the Declaration of Conformity is issued under sole responsibility of the manufacturer and belongs to the above-mentioned objects of the declaration.

Svetlana Bankovska
Managing director



Signature

07.02.2020.

Date

DEN-1, DEN-1B

Densitometers

Suspension turbidity detectors



If you have any feedback on our products or services, we would like to hear from you.
Please send all feedback to:

Manufacturer:

SIA Biosan
Ratsupites 7 k-2, Riga, LV-1067, Latvia

Phone: +371 674 261 37

Fax: +371 674 281 01

<https://biosan.lv>

Marketing: marketing@biosan.lv

Service: service@biosan.lv

Contents

1.	About this edition of user instructions.....	3
2.	Safety precautions	4
3.	General information.....	6
4.	Getting started.....	7
5.	Operation	8
6.	Calibration	10
7.	Specifications	11
8.	Ordering information	12
9.	Care and maintenance	13
10.	Storage and transportation.....	13
11.	Warranty.....	14
12.	EU Declaration of conformity.....	14

1. About this edition of user instructions

1.1 The current edition of the user instructions applies to the following models:

Model and name	Version
DEN-1 , densitometer, suspension turbidity detector	V.3AW
DEN-1B , densitometer, suspension turbidity detector	V.3AW

1.2 Edition 3.02 – January of 2022

2. Safety precautions

2.1 Symbols used in these instructions.



Caution! Make sure you have fully read and understood the present user instructions before using the equipment. Please pay special attention to sections marked by this symbol.

2.2 Symbols and icons used on the unit and packaging.

	CE marking, manufacturer affirms conformity with European health, safety, and environmental protection standards, see 12.1
	WEEE directive marking, see 12.1
	Polarity of the power connector
	Equipment uses direct current

2.3 General safety.

- The protection provided can be ineffective if the operation of the appliance does not comply with the manufacturer's requirements.
- Save the unit from shocks and falling.
- Store and transport the unit as described in section **Storage and transportation**.
- Use only original parts and accessories, provided by manufacturer for this product.
- Before using any cleaning or decontamination methods except those recommended by the manufacturer, check with the manufacturer that the proposed method will not damage the equipment.
- Do not make modifications in design of the unit.

2.4 Electrical safety.

- Connect only to the mains with voltage corresponding to that on the serial number label.
- Use only the external power supply provided with this product.
- Ensure that the power plug is easily accessible during use.
- Disconnect the unit from the mains before moving.
- If liquid penetrates into the unit, disconnect it from the mains and have it checked by a repair and maintenance technician.
- Do not operate the unit in premises where condensation can form. Operating conditions of the unit are defined in the **Specifications** section.

2.4.1 **Batteries** (only for model **DEN-1B**)



Caution! Risk of fire and explosion!

- Use only AA size batteries, rechargeable or non-rechargeable.
- Replace all used batteries in the unit at the same time. Insert batteries properly, with the plus (+) and minus (–) terminals aligned correctly. In case of doubt, turn off the unit immediately and check the polarity.
- Keep all batteries in a safe place away from children and pets.
- Where possible, recycle the batteries. Contact local government for information about the disposal options in the area.
- Remove batteries from the unit if it will not be used for several months to avoid battery leakage.
- Do not mix old and new batteries, batteries of different brands, or batteries of different types (e.g. zinc chloride and alkaline batteries) in the same unit as this may cause the batteries to leak.
- Do not attempt to recharge non-rechargeable batteries. This can cause batteries to overheat or leak.
- Do not place batteries in a refrigerator. This will not 'recharge', increase storage life, or increase batteries' power.
- Do not exceed storage temperature, it reduces battery performance and may also lead to leakage.
- Do not remove the battery label, or attempt to take the battery apart, or dispose of in a fire as this may lead to rupture and/or chemical burns.

2.5 **During operation.**

- Do not operate the unit in environments with aggressive or explosive chemical mixtures. Please contact manufacturer for possible operation of the unit in specific atmospheres.
- Do not operate the unit if it is faulty or has been installed incorrectly.
- Do not use outside laboratory rooms.
- Use **Select** and **Install** buttons only for calibration of the unit. Pressing the buttons can cause loss of calibration.

2.6 **Biological safety.**

- The user is responsible to carry out appropriate decontamination if hazardous material spills on or penetrates into the equipment.

3. General information

DEN-1 & DEN-1B densitometers are designed for solution turbidity measurement in the range of 0.0 - 6.0 McFarland units or 0 cells/ml – 18×10^8 cells/ml. **DEN-1 & DEN-1B** are capable of measuring solution turbidity in a wider range, up to 15.0 McFarland units, however, it is necessary to remember that in this case the standard deviation values increase.

DEN-1 & DEN-1B densitometers are used for 1) determining concentration of cells (bacterial, yeast cells) in the fermentation process, 2) detection of susceptibility of microorganisms against antibiotics, 3) identification of microorganisms with various test systems, 4) measuring optical density at fixed wavelength and 5) quantitative evaluation of concentration of dyed solutions that absorb green light.

The operation principle is based on optical density measurement with digital result representation in McFarland units.

The unit is calibrated at the factory and saves calibration data when being switched off. However, it can be recalibrated by multiple points in 0.0–6.0 McF range if necessary. We recommend using our Biosan standards for optimal results, but both commercial standards and the cell suspensions prepared in the laboratory (e.g., BaSO_4) can be used for calibration.

Table 1. Interpretation of McFarland Standard results into corresponding numeric values of bacterial suspension concentration and their optical density at 550 nm.

McFarland Standard	Composition	Interpretation	
	Concentration of BaSO_4	Bacterial concentration ¹	Theoretical optical density ² at 550 nm
0.5	2.40×10^{-5} mol/L	150×10^6 cells/mL	0.125
1	4.80×10^{-5} mol/L	300×10^6 cells/mL	0.25
2	9.60×10^{-5} mol/L	600×10^6 cells/mL	0.50
3	1.44×10^{-4} mol/L	900×10^6 cells/mL	0.75
4	1.92×10^{-4} mol/L	1200×10^6 cells/mL	1.00
5	2.40×10^{-4} mol/L	1500×10^6 cells/mL	1.25
6	2.88×10^{-4} mol/L	1800×10^6 cells/mL	1.50

¹ Bacterial concentration depends on microorganism size. The numbers represent an average value valid for bacteria. For yeasts, which are larger, these numbers should be divided by about 30.

² Values correspond to optical densities of bacterial suspensions. The BaSO_4 solutions optical density values differ, because the particle size and form differ from those of bacteria and light is diffracted differently

4. Getting started

4.1 **Unpacking.** Remove packing materials carefully and retain them for future shipment or storage of the unit. Examine the unit carefully for any damage incurred during transit. The warranty does not cover in-transit damage. Warranty covers only the units transported in the original package.

4.2 **Complete set.** Package contents:

4.2.1 Standard set:

- **DEN-1 / DEN-1B** Densitometer, suspension turbidity detector 1 pce.
- **A-16** adapter for Ø16 mm tubes..... 1 pce.
- AA batteries (for **DEN-1B** only) 3 pcs.
- External power supply 1 pce.
- User instructions, declaration of conformity 1 copy

4.2.2 Optional accessories, on request:

- **A-12** adapter for Ø12 mm tubes..... 1 pce.
- **CKG16** calibration kit for Ø16 mm glass tubes 1 set
- Calibration kit for Ø18 mm glass tubes..... 1 set
- Calibration kit for Ø12 mm glass tubes..... 1 set
- Glass test tubes, 16x100 mm 1 set of 100 pcs.
- Glass test tubes, 18x100 mm 1 set of 100 pcs.

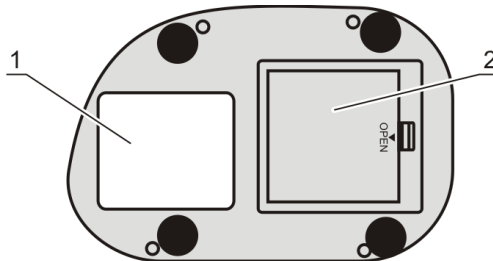

Figure 1. View from below

4.3 **Setup.**

- (for **DEN-1B**) Battery installation. Pull back the pin on the battery compartment (fig. 1/2) on the underside and open lid. Insert batteries as shown on the scheme inside and close the lid.
- Place the unit on horizontal even working surface.
- Connect the external power supply unit into the socket at the rear side of the unit (fig. 3/2) and position the unit for an easy access to the external power supply and the power switch.



Note. For **DEN-1B**, connecting external power supply is optional when the batteries are in use.

- Remove the protective film from the display.

4.4 **Factory calibration.** The device is pre-calibrated at the factory for operation with the glass tubes 16 mm in external diameter (see the label on the bottom side of the unit, fig. 1/1) at temperature range from +15°C to +25°C and saves calibration data when being switched off.



Note. Recalibrate the unit before using the tubes that are different from factory calibrated (e.g. with different outer diameter, bottom shape or different material such as plastic). See the **Calibration** section of this manual.

5. Operation

5.1 Recommendations during operation.

- Remove the tube with the solution from the socket before switching the unit on or off.
- We recommended keeping the unit switched on for 15 minutes before starting the operation in order to stabilize it in the working mode.
- If flat-bottomed tubes are used, the solution level should be higher than 7 mm from a tube bottom; if round-bottomed tubes are used - higher than 12 mm from a tube bottom.
- Check if the A-16 adapter is in the socket (fig. 2/1). The device is calibrated for operation with the glass tubes 16 mm in external diameter. To use different tubes, recalibrate the unit, see the **Calibration** section of the manual.

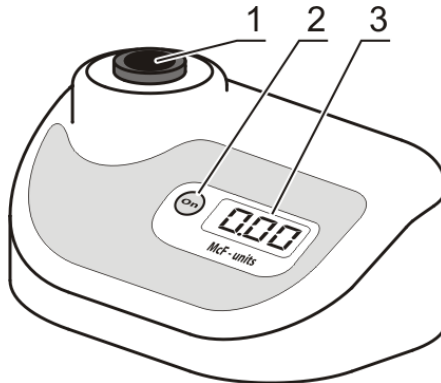

Figure 2. Front view

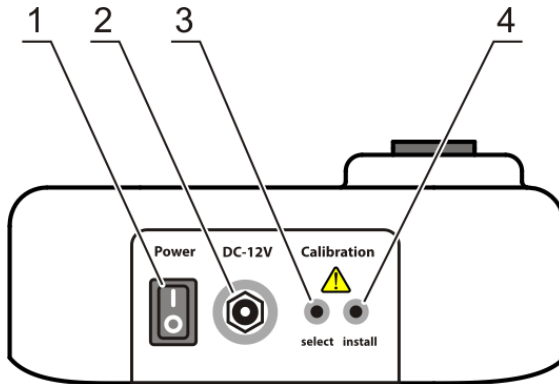

Figure 3. Back view

5.2 Connect the external power supply to electric circuit. Switch on the unit using the **Power** switch (fig. 3/1) on the rear panel.



Note. **DEN-1B** can operate without external power supply on battery power.

5.3 The following indication may be shown on the display (fig. 2/3):

- □.□□ – the unit is calibrated and ready for operation.
- LO BAT (**DEN-1B**) – low batteries, replace the batteries as described in **4.3** or connect the external power supply.



Note. The display of **DEN-1B** switches off if the socket is empty for longer than one minute. Press the **On** key (fig. 2/2) to activate the unit.

5.4 Shake the tube with the solution. It is recommended to use a vortex for shaking, e.g. **Biosan V-1 plus**.

5.5 To ensure measurement precision, check the external diameter of tubes. By default, the unit works with Ø16 mm tubes, with **A-16** adapter.



Caution! Recalibrate the unit before using the tubes that are different from factory calibrated (e.g. with different outer diameter, bottom shape or different material such as plastic). See the **Calibration** section of this manual.

5.6 Insert the tube into the socket of densitometer (fig. 2/1). The McFarland value for the solution will be shown on the display (fig. 2/3).

5.7 After finishing the operation switch off the unit using the **Power** switch (position **O**). If the external power supply is used, disconnect it from electric circuit.

6. Calibration

- 6.1 The unit is pre-calibrated at the factory for operation with the glass tubes 16 mm in external diameter (see the label on the bottom side of the unit, fig. 1/1) at temperature range from +15°C to +25°C and saves calibration data when being switched off. To use different types of tubes, recalibrate the unit as shown below.
- 6.2 Before using the standards, prepare them by the instructions from the manufacturer.
- 6.3 Perform calibration from lower to higher calibration value. Use at least 2 points for calibration. Different calibration points are available: 0.00, 0.50, 1.00, 2.00, 3.00, 4.00, 5.00, 6.00.
- 6.4 Connect the external power supply to electric circuit. Switch on the unit using the **Power** switch (fig. 3/1) on the rear panel.



Note. DEN-1B can operate without external power supply on battery power.



Caution! Make sure that the tube socket is empty. For Ø12 mm or Ø16 mm tubes, place the **A-12** or **A-16** adapters, accordingly.

- 6.5 Press the **Select** button (fig. 3/3) on the rear of the unit.



Note. Use a thin pin of maximum diameter of 2 mm for pressing the **Select** and **Install** buttons.

- 6.6 It is necessary to set values for an empty socket $-. -$ and transparent standard $\square.\square\square$.

- 6.6.1 **Empty socket.** Display shows $-. -$ indication. Press **Install** button (fig. 3/4) to save empty socket value. Display shows next required calibration value.

- 6.6.2 **Transparent standard.** Display shows $\square.\square\square$ indication. Insert standard for **0.00** value into the socket (fig. 2/1) of the unit. If the standard for 0.00 value is not available, fill the tube (of the kind that is used for operations) with distilled water. Use the tube as the **0.00** value standard. Press **Install** button to save transparent standard value. Display shows next required calibration value.



Note. Calibrate the unit using as many points as possible to obtain precise results. Minimum requirement are 2 points closest to the working range limits (e.g. 0.00 and 6.00 for operation in 0.00–6.00 McF range).

- 6.7 **Common calibration rules.** Display shows indication of necessary calibration value. Insert the necessary standard into the socket (fig. 2/1) of the unit and press the **Install** button to save the value for current standard.



Note. If pressing the **Install** button does not switch to the next standard value, it means that the current standard in the socket has lower turbidity value than the previous standard. Shake or replace the standard.

- 6.8 If a standard is not available, press the **Select** button to skip to the next calibration value without recording the value.
- 6.9 Repeat steps **6.7-6.8** until the calibration is complete. After recording or skipping the last value, unit automatically exits calibration mode and is ready for operation.
- 6.10 **Reset to factory calibration.** To reset the calibration of the unit to factory settings, ensure that you are in the working mode and the socket of the unit is empty. Press and hold **Install** key for 5 seconds. The unit displays a dot $.$, then changes it to $\square.\square\square$. The values are now reset.
- 6.11 Switch off the unit using the **Power** switch (position **O**). If an external power supply is used, disconnect it from electric circuit.

7. Specifications

7.1 Biosan is committed to a continuous programme of improvement and reserves the right to alter design and specifications of the equipment without additional notice.

7.2 Measurement specifications

Light source.....	LED
Wavelength	$\lambda = 565 \pm 15 \text{ nm}$
McFarland unit range.....	0.00–15.00 McF
Resolution	0.01 McF
Accuracy, in the factory calibration range.....	$\pm 3\%$ of the full scale
Measurement time.....	1 s
Sample volume.....	2 mL minimum
External diameter of tubes.....	12 mm (with A-12), 16 mm (with A-16) or 18 mm

7.3 General specifications

Display.....	LCD
Dimensions (L x W x H).....	165 x 115 x 75 mm
Weight, within $\pm 10\%$	0.7 kg
Power consumption.....	0.1 W
Input voltage and current.....	12 V, 7 mA
External power supply	input 100–240 V~, 50/60 Hz; output 12 V=
Batteries (only DEN-1B)	3 x AA

7.4 Workroom requirements

Workroom description	Cold rooms and closed laboratory rooms, incubators (except CO ₂ incubators)
Temperature range	+4 °C ... +40 °C
Humidity requirements	Maximum of 80% RH at 31 °C, decreasing linearly to 50% RH at 40 °C. Non-condensing atmosphere.
Operating height, maximum	2000 m ASL
Overvoltage category	I
Pollution degree	2

8. Ordering information

8.1 Models and versions available:

Model	Version	Catalogue number
DEN-1 , densitometer, suspension turbidity detector	V.3AW	BS-050102-AAF
DEN-1B , densitometer, suspension turbidity detector	V.3AW	BS-050104-AAF

8.2 To inquire about or order the optional accessories or the replacement parts, contact Biosan or your local Biosan representative.

8.3 Optional accessories:

Description	Catalogue number
A-12 , adapter for Ø12 mm tubes	BS-050102-IK
CKG16 , calibration kit for Ø16 mm glass tubes. Latex particles	BS-050102-BK
Calibration kit for Ø12 mm glass tubes. Polymer particles	21255
Calibration kit for Ø18 mm glass tubes. BaSO ₄ suspension	70900
Glass Test Tubes 16x100mm, high borosilicate, PP Cap with silicone pad.	BS-050102-MK
Glass Test Tubes 18x100mm, high borosilicate, PP Cap with silicone pad.	BS-050102-NK

8.4 Replacement parts:

Description	Catalogue number
A-16 , adapter for tubes of 16 mm in external diameter	BS-050102-AK

9. Care and maintenance

9.1 Service.

- 9.1.1 If the unit is disabled (e.g., no reaction to tube insertion or key presses, etc) or requires maintenance, disconnect the unit from the mains and contact Biosan or your local Biosan representative.
- 9.1.2 All maintenance and repair operations (except listed below) must be performed only by qualified and specially trained personnel.
- 9.1.3 Operating integrity check. If the unit follow the procedure described in sections **Operation** and **Calibration**, then no additional checks are required.

9.2 Cleaning and disinfection.

- 9.2.1 Use mild soap and water with a soft cloth or sponge for cleaning the exterior. Rinse remaining washing solution with distilled water. Wipe dry the excess water with clean, soft cloth or sponge.
 - 9.2.2 To disinfect the plastic parts, use 75% ethanol or DNA/RNA removing solution (e.g. Biosan **PDS-250**). After disinfecting it is necessary to wipe the surfaces dry.
 - 9.2.3 Internal (optical parts). Do not use liquids to clean optical parts. Use air from a rubber siphon to blow away any particles.
 - 9.2.4 The unit and its accessories are not autoclavable.
- 9.3 **Decommissioning of the unit.** The user is responsible for the decontamination of the unit before decommissioning. Dispose of the appliance as electronic equipment in accordance with the relevant national laws.

10. Storage and transportation

- 10.1 Store and transport the unit in a horizontal position (see package label) at ambient temperatures between -20°C and +60°C and maximum relative humidity of 80%.
- 10.2 After transportation or storage and before connecting it to the electric circuit, keep the unit under room temperature for 2-3 hrs.
- 10.3 For extended storage of the DEN-1B model, remove the batteries (see **4.3**). The DEN-1 model does not require special procedures.

11. Warranty

- 11.1 The Manufacturer guarantees the compliance of the unit with the requirements of Specifications, provided the Customer follows the operation, storage and transportation instructions.
- 11.2 The warranted service life of the unit from the date of its delivery to the Customer is 24 months. Extended storage does not extend the warranty. For extended warranty, see 11.5.
- 11.3 Warranty covers only the units transported in the original package.
- 11.4 If any manufacturing defects are discovered by the Customer, an unsatisfactory equipment report shall be compiled, certified and sent to the local distributor address. To obtain the claim form, visit **Technical support** page on our website at link below.
- 11.5 Extended warranty.
 - For **DEN-1B**, the *Premium* class model, one year of extended warranty is available free of charge after registration, during 6 months from the date of sale. Online registration form can be found in section **Warranty registration** at the link below.
 - For **DEN-1**, the *Basic Plus* class model, extended warranty is a paid service. Contact your local Biosan representative or our service department through the **Technical support** section on our website at the link below.
- 11.6 Description of the classes of our products is available in the **Product class description** section on our website at the link below.

Technical support



biosan.lv/en/support

Registration



biosan.lv/register-en

Product class description



biosan.lv/classes-en

- 11.7 The following information will be required in the event that warranty or post-warranty service comes necessary. Complete the table below and retain for your records.

Model	Serial number	Date of sale
DEN-1, DEN-1B, McFarland Densitometer		

- 11.8 **Production date.** Production date is placed in the serial number, on the label of the unit. Serial number consists of 14 digits styled XXXXXYYMMZZZZ, where XXXXXX is model code, YY and MM – year and month of production, ZZZZ – unit number.

12. EU Declaration of conformity

12.1 Densitometers, suspension turbidity detectors **DEN-1** and **DEN-1B** are in conformity with the following relevant Union legislations:

LVD 2014/35/EU	LVS EN 61010-1:2011 Safety requirements for electrical equipment for measurement, control, and laboratory use. General requirements.
EMC 2014/30/EU	LVS EN 61326-1:2013 Electrical equipment for measurement, control and laboratory use. EMC requirements. General requirements.
RoHS3 2015/863/EU	Directive on the restriction of the use of certain hazardous substances in electrical and electronic equipment.
WEEE 2012/19/EU	Directive on waste electrical and electronic equipment.

12.2 Declaration of Conformity is available for download on the page for the relevant model on our website by links below, in the **Downloads** section:

Biosan SIA

Ratsupites 7 k-2, Riga, LV-1067, Latvia

Phone: +371 67426137 Fax: +371 67428101

<https://biosan.lv>

Edition 3.02 – January of 2022