

## Technical File

Product Name:

### 1. Blood Transfusion Sets for Single Use

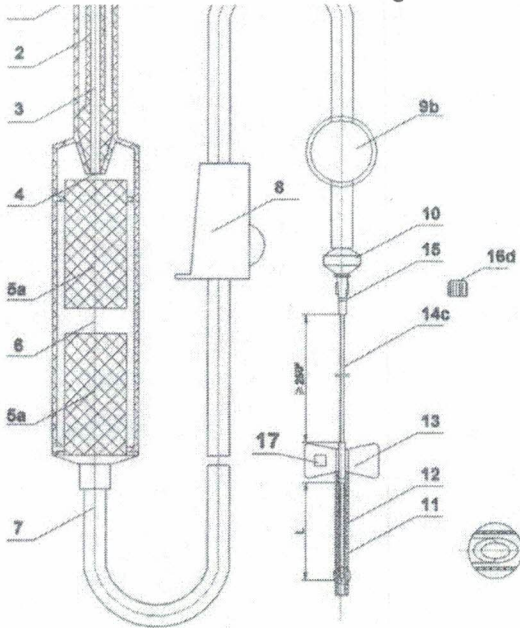

1. Protective cap of closure-piercing device;
2. Closure-piercing device ; 3. Fluid channel
4. Drip tube 5. Blood and blood component filters
6. Drip Chamber 7. Tubing 8. Flow regulator;
9. Injection Set 10. Outer taper joint;
11. Needle Tube 12. Needle protective cap;
13. Needle handle 14. Soft tube;
- 15, Connective Site 16. Protective cap
17. Needle outer carton spec. 18G x 1 1/2 (or special order)

a. Indicates the alternative location of blood and blood component filters, if safe, Other designs work, too

b. Injection site is optional;

c. Soft tube length size is recommended;

d. It may be supplied without a protective cap when assembled with blood transfusion products;

Remark: The connecting site can be equipped with protective devices;

Picture 1 Transfusion Blood Set (with needle) sample

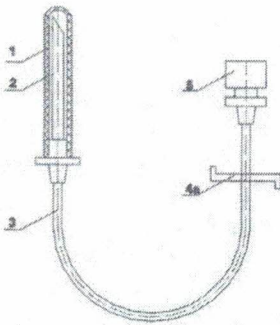

1. Protective cap;
2. Closure-piercing device;
3. Tube channel;
4. clamp;
5. Air intake device with air filter;

Picture 2. Example of a typical intake device



#### 1.1.4 Product Labeling

The product label of blood transfusion device is TS, the number of intravenous infusion needle Z, the nominal outside diameter of the needle tube, the nominal length of the needle tube, the type of the wall of the needle tube and the Angle of the first inclined plane of the needle tip. The type of tube wall is expressed as RW (normal wall), TW (thin wall) or ETW (ultra-thin wall), and the Angle of the first bevel of the tip is expressed as LB (long bevel Angle) or SB (short bevel Angle).

Marking example: TS1-Z 0.8x28 TW SB, indicating a disposable blood transfusion set of model TS1 with a needle. The nominal external diameter of the intravenous infusion needle tube is 0.8mm, the nominal length of the needle tube is 28mm, the wall type of the needle tube is thin wall, and the Angle of the first bevel of the needle tip is short bevel Angle.

#### 2. Performance index

The materials for the manufacture of the blood transfusion set out in Chapter 1, the infusion needle used with the blood transfusion set and the air intake device shall conform to the requirements specified in Chapter 2. The components of the blood transfusion in contact with blood and blood components shall also comply with the requirements set forth in Chapter 3. The needle tube of infusion needle should meet the requirements of GB18457-2001.

2.1 Blood Transfusion Set Blood transfusion set with needle (hereinafter referred to as blood transfusion)

##### 2.1.1 Particulate pollution

Blood transfusion devices should be manufactured with minimal particulate contamination. The surface of the liquid path shall be smooth and clean, and shall not exceed the contamination index when tested as specified in Chapter A.1 of Appendix GB8369-2005.

##### 2.1.2 Leakage

There shall be no gas leakage during the test in accordance with Chapter A. 2 of Appendix GB8369-2005.

##### 2.1.3 Tensile strength

The connection between the components of the blood transfusion fluid channel (excluding the protective sleeve) shall be able to withstand no less than 15N static tension for 15s.

##### 2.1.4 Cork Piercer

2.1.4.1 The size of the cork piercer shall be as shown in Figure 3.

2.1.4.2 Stopper piercers and air intake devices (if used) shall be able to Pierce the stopper of unpierced blood and containers for blood components. It is advisable not to cause shavings during puncture.

## 2.1.5 Air intake device

2.1.5.1 Air intake devices shall meet the requirements of 1.2 and 2.4.1.

2.1.5.2 The intake device shall have an air filter to prevent microorganisms from entering the inserted container.

2.1.5.3 The air intake device shall be separated from the cork piercer.

2.1.5.4 If the end of the air intake device is connected to an air filter through a pipeline, the length of the hose shall not be shorter than 250mm.

2.1.5.5 The air filter shall be installed so that all air entering the rigid vessel passes through it, and the rate of reduction of the outflow from the free intake vessel shall not be greater than 20% when tested in accordance with Appendix A.3 of GB8369-2005.

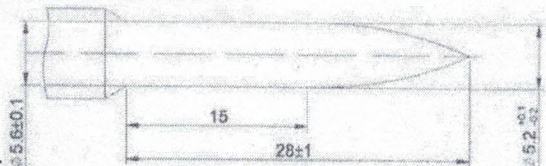

Unit: millimeter

Pic 3 Cork Piercer size

Remark: The size of 15mm in Figure 3 is the measurement basis, and the cross section of the puncture instrument is circular.

### 2.1.6 Pipes

2.1.6.1 Lines made of plastic materials shall be transparent or sufficiently transparent that the boundary between water and air can be observed with normal or corrected vision when bubbles pass through.

2.1.6.2 The length of the pipe from the end to the drip bucket (including injection parts (if any) and external tapered joints) shall not be less than 1550mm.

### 2.1.7 Blood and blood component filters

The blood transfusion device shall have a filter for blood and blood components. Filter mesh should be uniform, the total area should not be less than 10c square meters. When tested according to Appendix A.4 of GB8369-2005, the solid residue on the filter shall be no less than 80% of the mass fraction on the standard filter.

Note: If the tested blood filter wire diameter is not more than 100µm, aperture is not more than 200µm, can be exempted from filtration efficiency test.

### 2.1.8 Dropper and dropper

The drop bucket should allow continuous observation of the droplet. The liquid should pass through a dropper inserted into the dropper into the dropper. The distance between the end of the dropper and the outlet of the dropper shall be no less than 40mm, or the distance between the dropper and the blood and blood component filter shall be no less than 20mm. The distance between the dropper wall and the dropper terminal should not be closer to 5mm. Under the condition of (23±2) °C and flow rate of (50±10) drops/min, 20 drops of distilled water from the dropper should be (1±0.1) mL [(1±0.1) g].

Drops should be helpful in the liquid filling process.

### 2.1.9 Flow regulator

The flow regulator shall be able to regulate the flow of blood and blood components from zero to maximum.

The flow regulator should be able to be used continuously during a transfusion without damaging the line.

The flow regulator and the pipeline contact together when storing does not produce harmful reactions.

### 2.1.10 Flow Rate of blood and blood components

The blood transfusion device should be able to output no less than 1000mL of blood within 30min at (23±2) °C under 10kPa differential pressure. At a pressure of 30kPa above atmospheric pressure, the blood transfusion device should also output no less than 500mL of blood within 2min.

The blood should be collected in a suitable anticoagulant and stored for no less than 2 weeks without large blood clots.

Note: A glucose solution with a mass concentration of 400g/L can be used instead of blood.

### 2.1.11 Injection Kit

If self-sealing injection parts are available, the leakage of water shall not exceed one drop during the test in accordance with Chapter A.5 of Appendix GB8369-2005.

The injection parts should be located near the external taper joint.

### 2.1.12 External taper connector

The end of the pipeline shall have an external tapered joint conforming to GB/T1962.1-2001 or GB/T1962.2-2001.

### 2.1.13 Protective Cover

The protective sleeve of blood transfusion terminal should keep the bottle stopper puncture device, outer conical joint and blood transfusion device sterile, and the protective sleeve should be firm, but easy to remove.

2.2 Intravenous infusion needle for blood transfusion set with needle (hereinafter referred to as infusion needle)

#### 2.2.1 Particulate pollution

The contamination index of infusion needle should not exceed 90 when tested according to Chapter A. 1 of Appendix GB18671-2009.

### 2.2.2 Color scale

The color of the needle handle and/or protective sleeve should be used as the color code for the nominal outside diameter of the syringe. The color shall conform to the requirements of YY/T0296-2013.

### 2.2.3 Connection firmness

2.2.3.1 Apply 20N axial static tension to the connection of infusion needle handle and needle tube for 10s, and it should be opened or loosened continuously.

2.2.3.2 The connection between the hose and the needle handle of the infusion needle and the hose and the connecting seat should be able to withstand the static axial tension of 15N or 50% elongation (if reached first) for 10s, without loosening or separation of each connection.

### 2.2.4 Leakage

Leak.

The inner cavity of infusion needle should be well sealed. There shall be no leakage during the test in accordance with Appendix A.2 of GB 18671-2009

### 2.2.5 Traffic

When tested in accordance with Chapter A.3 of Appendix to GB 18671-2009, the effluent output shall be no less than that specified in Table 2 at A pressure of 20 kpa.

Table 2 Indicators of infusion needle flow

Spec / mm	0.8	0.9	1.1	1.2
Flow / (ml / min)	21.0	36.0	48.0	48.0

### 2.2.6 Needle Length

When the nominal length of the needle is less than or equal to 15mm, the length of the needle (L in Figure 1) should be  $\pm 1.0\text{mm}$  of the nominal value.  
When the nominal length is greater than 15mm, the length of the needle should be  $+1.5\text{mm}$  of the nominal value.  $-2.0\text{mm}$

Table 3 Length of infusion needle

Spec / mm	0.8	0.9	1.1	1.2
Nominal length of needle tube / (mm)	28	28	28	28

### 2.2.7 Needle tip

Infusion needle tip should be sharp, under the condition of 2.5 times magnification, with normal or corrected vision examination, needle tip should be free of defects such as burrs, burrs and bent hooks.

The Angle of the first bevel of the tip is  $(17\pm 2)^\circ$ , generally known as "short bevel Angle".

The evaluation method of needle puncture performance is given in chapter D.3 of Appendix of GB 18671-2009.

### 2.2.8 Lubricant

The needle tube is coated with lubricant To comply with the requirements of the Chinese Pharmacopoeia medical lubricant (dimethyl silicone oil), observed with normal or corrected vision, the outer surface of the needle tube should not be visible accumulation of lubricant.

Note 1: The amount of lubricant on the surface of the needle should not exceed 0.25mg per square centimeter.

### 2.2.9 Connecting seat

The tapered joint of the connecting seat shall conform to the requirements of GB/T 1962.1-2001 or GB/T1962.2-2001.

2.2.10 Needle handle should be complete, marked clearly, and the needle handle should be in the same direction as the Angle of the first bevel of the needle tip (as shown in FIG.1).

The tilt should not be greater than  $30^\circ$ .

### 2.2.11 Hose

The hose of the infusion needle should be soft, transparent and smooth, without obvious mechanical impurities, foreign bodies and kinks, and its transparency should ensure that bubbles and blood return can be observed.

### 2.2.12 Protective Sleeves

Infusion needle protective sleeve should not fall off naturally and be easily removed.

## 2.3 Chemical Requirements

The blood transfusion shall prepare test solution according to Appendix B of GB8369-2005.

Note: Chemical requirements include blood transfusion apparatus and matching infusion needle.

### 2.3.1 Reducing substance

When the reducing substance of blood transfusion is tested in accordance with Chapter B. 2 of Appendix GB8369-2005, the total amount of potassium permanganate solution [ $c(\text{KMnO}_4) = 0.002\text{mol/L}$ ] should not exceed 2.0mL.

### 2.3.2 Metal ions

When determined by atomic absorption spectrophotometry (AAS) or equivalent, the total content of barium, chromium, copper, lead, and tin in the extract should not exceed  $1\mu\text{g/mL}$ . Cadmium content should not exceed  $0.1\mu\text{g/mL}$ .

When tested according to Chapter B.3 of Appendix GB8369-2005, the color of the extract shall not exceed that of the standard control solution containing  $\beta(\text{Pb}^{2+}) = 1\mu\text{g/mL}$ .

### 2.3.3 pH titration

When the pH of the blood transfusion is tested according to Chapter B.4 of Appendix GB8369-2005, any standard solution required for the indicator to turn gray should not exceed 1mL.

### 2.3.4 Evaporation residue

Evaporative residue of blood transfusion apparatus when tested in accordance with Chapter B.5 of Appendix GB8369-2005, the total amount of dry residue shall not exceed 5mg.

### 2.3.5 UV absorbance of the extract

The absorbance of the extract of blood transfusion device should be no more than 0.1 when tested in accordance with Chapter B. 6 of Appendix GB8369-2005.

### 2.3.6 Residual ethylene oxide

When tested according to GB/T14233.1-2008, the residual amount of ethylene oxide should not be greater than 0.5mg per blood transfusion set.

## 2.4 Biological Requirements

Note: Biological requirements include blood transfusion apparatus and matching infusion needle.

### 2.4.1 Sterility

The product shall be sterile according to the test method specified in GB/T14233.2-2005.

### 2.4.2 Pyrogen

Appropriate tests should be performed to evaluate the pyrogen absence of blood transfusion and/or air intake devices, and the results should indicate that the transfusion is pyrogen free. Pyrogen tests shall be performed in accordance with Chapter C.1 of GB8369-2005.

