

354 overhead suspended shield & LED 300DF SC lamp

354/P76/LED3DF-001 (ceiling mounted, 76 cm x 61 cm centre mounted lead acrylic shield with patient contour cut-out & LED 300DF SC surgical lamp)

Static mounted upper body protection

This 76 cm x 61 cm shield uses 0.5 mm equivalent lead acrylic (@150 kV) for effective protection to the upper body. The central mount system allows 360 degrees of rotation ensuring the shields corner cut-out can be effectively positioned over a patient. An optional 0.5 mm Pb equivalent curtain can be added to further reduce scatter emanating from the patient. The LED 300DF SC lamp is a single colour surgical light with a light output of 160,000 lux.

354 x-ray shield, 76 cm x 61 cm with corner cut-out

- > 0.5 mm equivalent lead acrylic (@150 kV).
- > Central mount system allows 360 degrees of rotation.
- > Optional: 0.5 mm Pb equivalent flexible curtain fitted across the 61 cm lower profile (354/P/LR).

LED 300DF SC single colour surgical lamp

- > Light intensity at 1 metre: 160,000 Lux.
- > Colour rendering index R_a 96.
- > Light field size: 19 cm to 26 cm.
- > Electronic dimming.
- > Colour temperature: 4500 Kelvin.
- > Temperature increase at head area: 0.5°C.
- > Total power consumption: max 89W.
- > Light source: 36 LED's.
- > Life span of 60,000 hours.
- > Diameter of lamp head: 55 cm.
- > Detachable sterilizable handle included.

Stationary system

- > Consisting of:
 - 80 cm ceiling column*
 - 2 x two-part suspension arm
 - 76 x 61 cm shield with corner cut-out
 - LED 300DF SC lamp
- > Optional installation aid #300/P/004 can be used to attach a column to Unistrut rails (or equivalent) in a suspended ceiling (see over).
- > Ceiling column can be statically mounted to the ceiling or attached to a moveable carriage in a ceiling track (see over).

* See over - other lengths available.

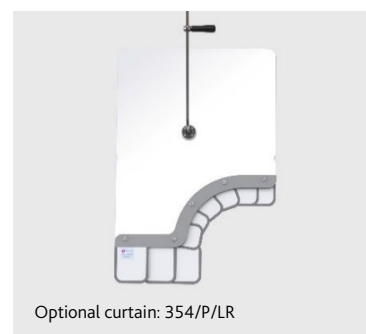

Technical specification

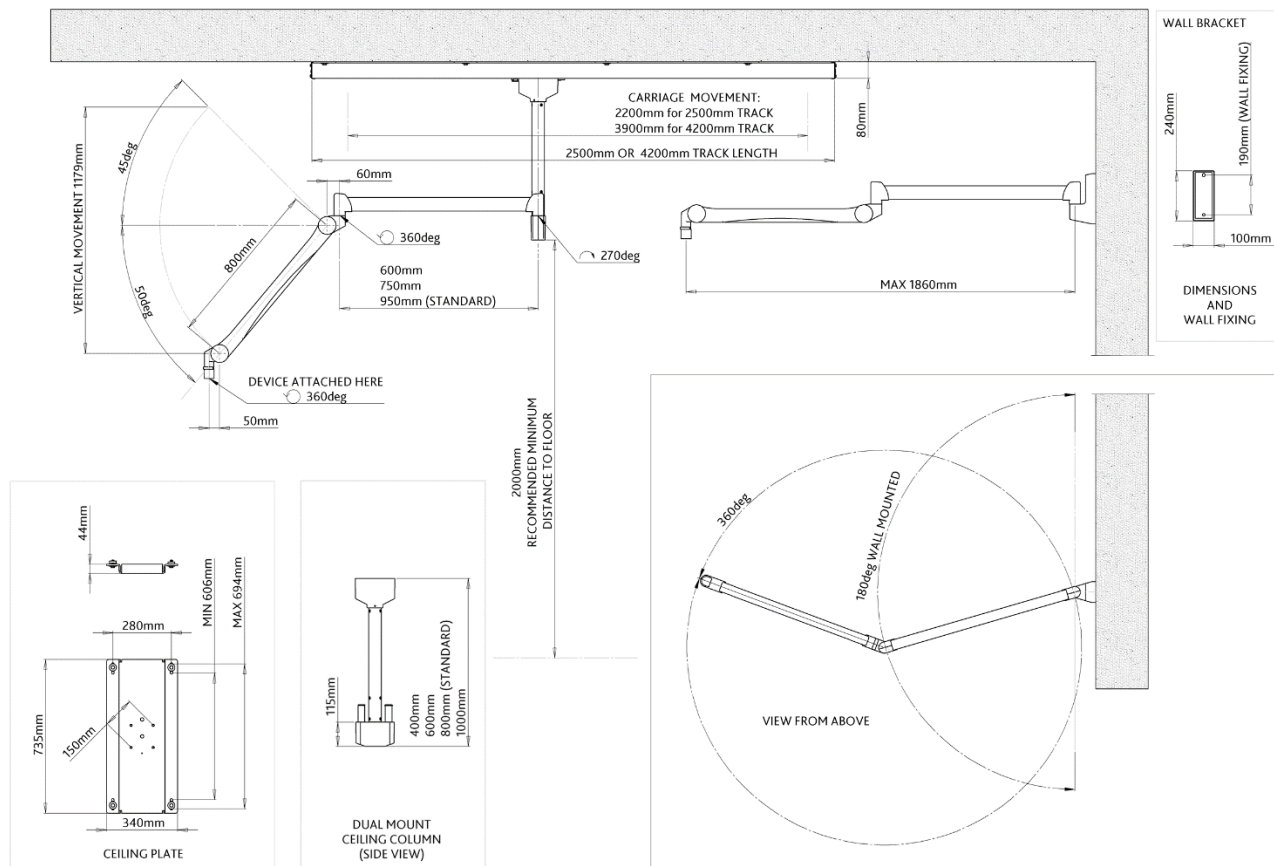

Equipment weights & part numbers

354/P76/LED3DF-001

Power supply in housing

LED 300DF SC lamp head: **12 kg**

76 x 61 cm type 354 shield assembly with corner cut-out: **9.5 kg**

2 x Suspension arm: **10.4 kg** (each)

80 cm dual mount ceiling column: **12.5 kg**

Optional equipment:

Dual mount ceiling column:

40 cm (#300/COLUMN/40): **10 kg**

60 cm (#300/COLUMN/60): **11.2 kg**

100 cm (#300/COLUMN/100): **14.7 kg**

Installation aids:

Ceiling mounting plate (#300/P/004): **14.8 kg**

Ceiling anchorage mount (#300/P/012): **37 kg**

Ceiling void installation (#300/P/014): **7.8 kg**

Ceiling track & carriage:

2.5 m (#3001/TC/250): **50 kg**

4.2 m (#3001/TC/420): **72 kg**

Track cable management:

2.5 m (#3001/TC/250/EC): **1.3 kg**

4.2 m (#3001/TC/420/EC): **1.7 kg**

Additional track carriage:

For use in 2.5 m or 4.2 m track (#3001/3.25): **4.6 kg**

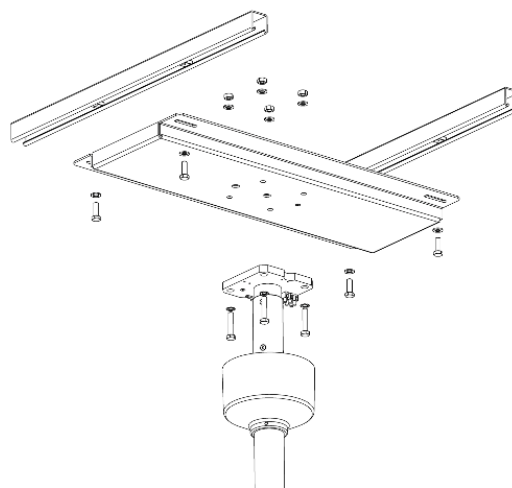

Ceiling mounting plate #300/P/004
(Shown with ceiling rails and ceiling column)