

PART OF THE
TECHNICAL DOCUMENTATION

PRODUCT DESCRIPTION
AGILON®
SHOULDER SYSTEM

PRODUCT-GROUP: PRIMARY SHOULDER ARTHROPLASTY

RISK-CLASS: III

LOCATION: SHOULDER

DATE: 14.02.2022, REV. 2

TABLE OF CONTENTS

1. AGILON® Shoulder System	5
2. Intended Use	8
3. Qualification of the Product as a Medical Device	8
4. Risk-Class: III	8
5. Intended User	8
6. Target Group	8
7. Indications	8
8. Contraindications	9
9. Risk Factors	9
10.1.1 AGILON® Cap	10
10.1.2 AGILON® CTA Cap	11
10.1.3 AGILON® Cap Inverse	11
10.1.4 AGILON® Retentive Cap Inverse	12
10.2 Glenoid Components	13
10.2.1 AGILON® Glenoid Cementless Round (Glenoid Baseplate Round) .	13
10.2.2. AGILON® Glenoid Cementless Anatomical	13
10.2.3. AGILON® Glenoid PE-Insert	14
10.2.4. AGILON® PE-Glenosphere	14
10.3 Humeral Components with Extended Fit	15
10.3.1 AGILON® Screw (REF 382100XX)	15
10.3.2. AGILON® Extension Piece (REF 38210XXX)	15
10.3.3. AGILON® Metaphyseal Component Trauma (REF 382100XX)	15
10.3.4. AGILON® Metaphyseal Component Omarthrosis (REF 382100XX) .	17
10.3.5 AGILON® Stem Cementless (REF 385XXXXX)	17
10.3.6. AGILON® Stem Cemented (REF 384XXXXX)	18
10.4. Humeral Components Without Extended Fit	19
10.4.1. AGILON® Screw (REF 382000XX)	19
10.4.2. AGILON® Extension Piece (REF 38200XXX)	19
10.4.3. AGILON® Metaphyseal Component Trauma (REF 38200001)	19
10.4.4. AGILON® Metaphyseal Component Primary (3820000X)	20
10.4.5. AGILON® Stem Cementless(REF 383XXXXX)	21
10.4.6. AGILON® Stem Cemented (REF 382XXXXX)	21

10.4.7. Safety Screw (REF 38200101)	21
10.5 Metaphyseal Implant	22
10.5.1. AGILON® MI	22
11. Materials	23
12. Coatings / Surfaces	24
12.1 Caps	24
12.2 Glenoid Components	24
12.3 Humeral Components	25
12.4 Metaphyseal Implant	27
13. Sizes and Dimensions	28
13.1. Caps	28
AGILON® Cap	28
AGILON® CTA Cap	29
AGILON® Cap Inverse	30
AGILON® Retentive Cap Inverse	31
13.2 Glenoid Components	32
AGILON® Glenoid Cementless Round	32
AGILON® Glenoid Cementless Anatomical	33
AGILON® Glenoid PE Insert	34
AGILON® PE-Glenosphere	35
13.3 Humeral Components with Extended Fit	36
AGILON® Screw (REF 382100XX)	36
AGILON® Stem Cementless	42
13.4 Humeral Components without Extended Fit	45
AGILON® Screw (REF 382000XX)	45
AGILON® Extension Piece (REF 38200XXX)	46
AGILON® Metaphyseal Component Trauma (REF 38200001)	47
AGILON® Metaphyseal Component Primary (3820000X)	47
AGILON® Stem Cementless (REF 383XXXXX)	49
AGILON® Stem Cemented (REF 382XXXXX)	51
Safety Screw	52
13.5 Metaphyseal Implant	53
AGILON® MI	53
14. Compatibility	54
15. Warnings	54

PRODUCT DESCRIPTION

AGILON® SHOULDER SYSTEM

16. Product List (Identification of the Products)	54
17. Reference to Previous Generations and Similar Devices	54
LIST OF FIGURES	55
LIST OF TABLES	57
LIST OF ABBREVIATIONS	58
DOCUMENT REVISION HISTORY	59



1. AGILON® Shoulder System

The modular AGILON® shoulder system is intended for hemi or total shoulder replacement (Fig. 1). The system consists of different functional components designed to reconstruct the glenohumeral joint. Depending on indication, the humeral component may be used in conjunction with a glenoid component for conventional total shoulder arthroplasty or to articulate directly with the anatomic glenoid in a hemi-shoulder application. The modularity and design of the AGILON® shoulder system allows modular adaption to the anatomical size, inclination, humeral offset, and retrotorsion of the shoulder and thereby enables restoring comfort and function to an arthritic or fractured shoulder.

The humeral component is available in modular design and consists of a humeral stem, a metaphyseal component and a humeral head (AGILON® cap). The AGILON® shoulder system was initially designed as a modular cemented trauma shoulder system for restoring a traumatically damaged shoulder joint. Thus, the metaphyseal component trauma allows the fixation of bone fragments of the trabecular to the prosthesis. In case of existing omarthrosis, the metaphyseal component omarthrosis should be used. The glenoid component is available as an all-polyethylene design or as a metal-back glenoid with a polyethylene insert.

Beside the anatomical design, the AGILON® shoulder system is available as an inverse version which might be necessary in the setting of rotator cuff tear arthropathy (Fig. 1- the third from the left). As a stemless option the AGILON® shoulder system offers a metaphyseal implant made of additive manufactured EPORE® structure (Fig. 1- on the right).



Fig. 1. AGILON SHOULDER SYSTEM OVERVIEW

Biomechanical Characteristics

The need for a modular shoulder endoprosthesis results from the variable anatomical ratios of the proximal humerus. The upper arm has an individually different inclination and retrotorsion with respect to the metaphyseal shaft axis. The AGILON® shoulder system allows modular adaptation to the anatomical size, the inclination, the humeral offset and the retrotorsion of the shoulder.

The inclination angle of the AGILON® shoulder system depends on the anatomical mean values and is 135°. In addition, the non-anatomical inclination angle of 155° is available, which allows a further adaptation to the individual conditions of the patient. Especially, in case of inverse prostheses an inclination angle of 155° provides a greater stability of the prosthesis against dislocation.

The AGILON® shoulder system allows a correction of length and retrotorsion of the prosthesis after implantation of the stem. The proximal length can be increased by using the different extension pieces. To adjust the rotation of the implant, the toothing of the stems, extension pieces and metaphyseal components enables a rotational adaptation to the anatomical retrotorsion in 10° steps.

The centre of the spherical humeral head after resection of the joint surface does not coincide precisely with the cylindrical centre of the humerus diaphysis in the transverse section. The distance between the two centres is designated as humeral offset. Numerous anatomical sizes and offsets can be adjusted due to eccentricity as well as various radii of curvature and heights of the AGILON® cap. The eccentric AGILON® cap enables a variable setting of the humeral offset.

Anatomical vs. inverse Shoulder Prosthesis

The shoulder is one of the most complex joints. In order to ensure its stability and movement, the muscles of the rotator cuff must be functioning. In a healthy shoulder, the rotator cuff muscles help position and power the arm during range of motion. In case of an existing rotator cuff defect, the glenohumeral rotation centre of the shoulder gets anterior-superior decentred and unstable. In that case, an anatomical prosthesis design is not able to achieve a normal shoulder mobility because it uses the rotator cuff muscles to function properly. Whereas, the inverse total shoulder replacement relies on the deltoid muscle, instead of the rotator cuff, to power and position the arm. Therefore, the inverse shoulder joint is indicated for primary shoulder joint replacement or revision due to a rotator cuff insufficiency. By improving the leverage ratios for the deltoid muscle with an inverse shoulder prosthesis, the glenohumeral centre of rotation can be medialized and caudalized to achieve a more favourable biomechanically situation.

The AGILON® shoulder prosthesis inverse consists of a glenoid, fixed in the bone, a spherical element (glenosphere) attached to the glenoid, a concave humerus cap, which articulates with the glenosphere, a metaphyseal component and a humeral stem. The three different heights of the inverse cap (S, M, and L) can be used to increase the tension of the M. deltoids by a lateralizing effect.

A known problem of inverse shoulder prostheses is the close contact between the medial edge of the humeral component and the lateral edge of the scapula, which leads to a so-called notching

PRODUCT DESCRIPTION

AGILON® SHOULDER SYSTEM

phenomenon. Inferior glenoid notching is caused due to a bone erosion caused by the impingement of the prosthesis at the scapula in the adduction of the arm. Beside the mechanical contact, the glenoid notching can result in progressive PE wear and ultimately to progressive osteolytic changes when the liner conventionally made of polyethylene impinges against the scapula. Due to the inversion of the materials, AGILON® provides an effective solution to avoid PE impingement on the scapula.

Components of the AGILON® Shoulder System

The modular AGILON® shoulder system consists of numerous components (Fig. 2). In the following sections the different model variants, design characteristics, sizes and dimensions, coating details as well as component compatibility information of the AGILON® shoulder system are described.

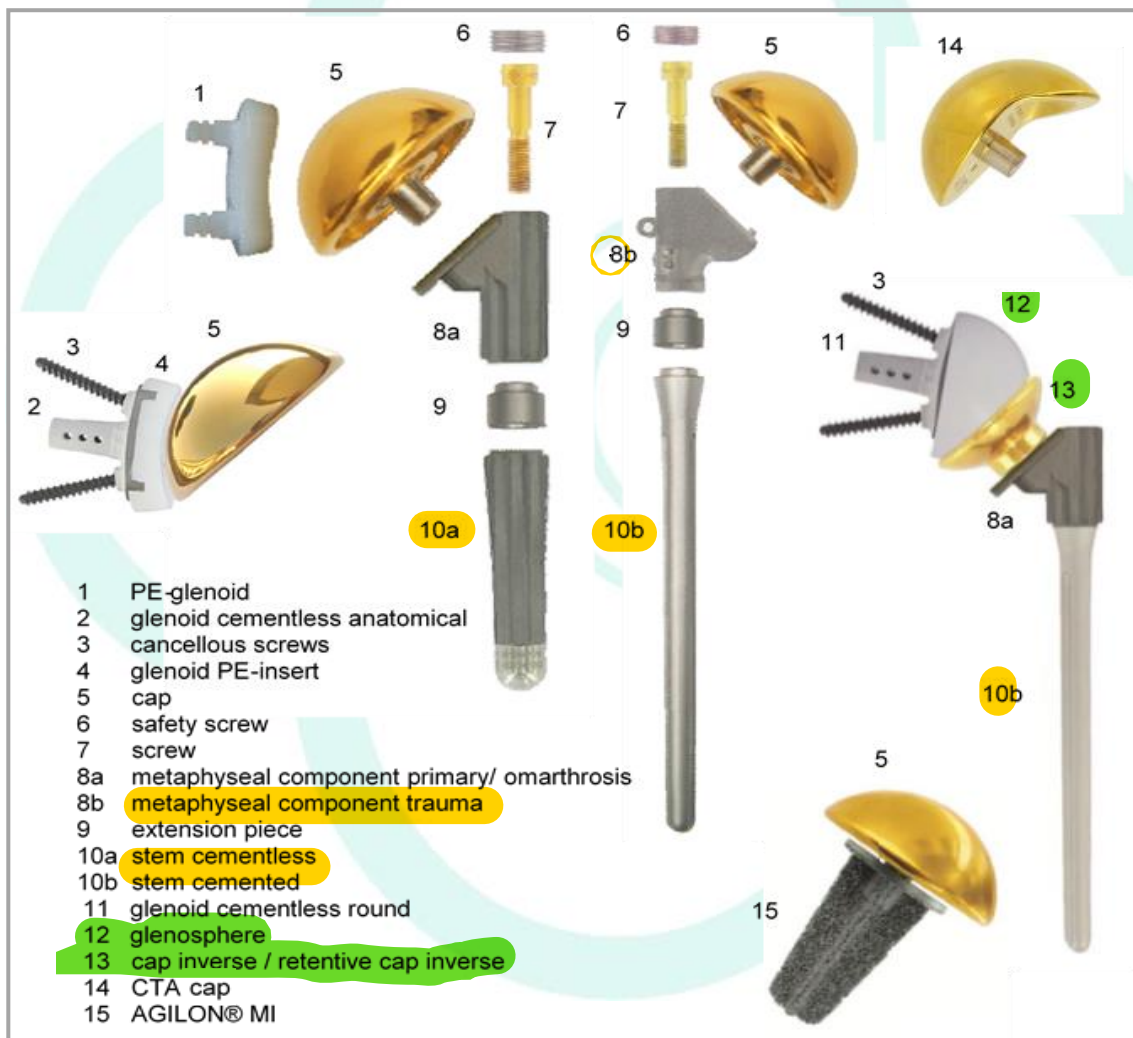

Fig. 2. COMPONENTS OF THE AGILON® SHOULDER SYSTEM

2. Intended Use

⇒ See Doc. „Fbl_423-1-2-4_Zweckbestimmung_AGILON“ in the folder “04 Produktbeschreibung”

3. Qualification of the Product as a Medical Device

The products of the AGILON® System are medical devices in accordance with the Definitions in Article 2 of the Medical Device Regulations MDR (EU) 2017/745 of 05. April 2017. The AGILON System are “medical devices” “for human beings for the specific medical purposes” as described in the Article 2 under (1) of the of the Medical Device Regulations MDR (EU) 2017/745 of 05. April 2017.

4. Risk-Class: III

The risk classification of the AGILON® System can be found in the following document:

⇒ See Doc. „Risk Classification_MDR 2017745_AGILON“ in the folder “01 Produktliste”

5. Intended User

The use of this implant is restricted to persons who, based on their education, knowledge and practical experience, are capable of proper handling and use of the device. Familiarity with the recommended surgical technique and its careful application as well as a pre-operative planning are essential to achieve the best possible outcome. The implantcast GmbH offers special user trainings to ensure an optimal preparation.

6. Target Group

The target group is patients that meet the indications given in these instructions for use and for whom the implantation of the AGILON® Shoulder System is a suitable therapy. The attending medical doctor decides if the product is suitable for the individual patient, and which implant is to be used. This decision depends on several factors, such as the patient’s age and weight, bone quality, shape of the bone and deformation of the joint.

7. Indications

Information about indications of the modular AGILON® Shoulder System can be found in the Instruction for Use.

⇒ See Doc. Instruction for Use “09300031 Schulterendoprothesen” in the folder “05 Kennzeichnung\Gebrauchsinformation”

8. Contraindications

Information about contraindications of the modular AGILON® Shoulder System can be found in the Instruction for Use.

⇒ See Doc. Instruction for Use “09300031 Schulterendoprothesen” in the folder “05 Kennzeichnung\Gebrauchsinformation”

9. Risk Factors

Information about risk factors of the modular AGILON® Shoulder System can be found in the Instruction for Use.

⇒ See Doc. Instruction for Use “09300031 Schulterendoprothesen” in the folder “05 Kennzeichnung\Gebrauchsinformation”

10. Design Description

10.1 Caps

10.1.1 AGILON® Cap

The AGILON® cap is characterized by a spherically design to replace the humeral head. The cap is mounted on a metaphyseal component via a 12/14 taper connection.

The cap can be inserted eccentrically in 12 different angles to facilitate the reconstruction of the human anatomy. The eccentricity of the caps enables the variation of the mediolateral offset (turn of respectively 30° grade) between - 2 mm and + 2 mm. Additional changing of the height of the cap ± 3 mm effects a change of the medial offset ± 2.1 mm.



Fig. 3. AGILON® CAP



Fig. 4. AGILON® CAP INNER SURFACE

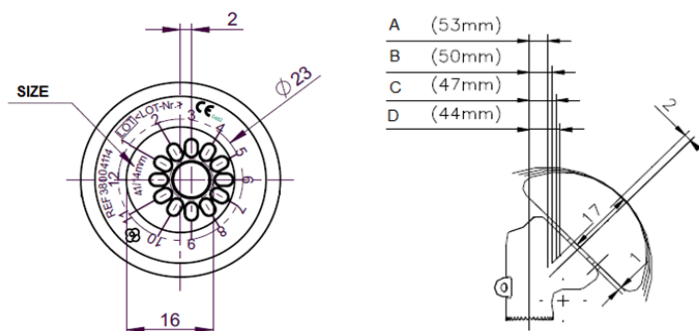

Fig. 5. AGILON® CAP - ECCENTRICITY



ECCENTRICITY		+2 mm (12 o'clock position)	0 mm (3 or 9 o'clock position)	- 2 mm (6 o'clock position)
				
A	53 mm	4.7 mm	6.1 mm	7.5 mm
B	50 mm	5.8 mm	7.2 mm	8.6 mm
C	47 mm	6.8 mm	8.2 mm	9.7 mm
D	44 mm	7.9 mm	9.3 mm	10.7 mm

TABLE 1: MEDIOLATERAL OFFSET DUE TO CAP ECCENTRICITY (17MM CAP)

10.1.2 AGILON® CTA Cap

The CTA cap is characterized by a spherically design with a laterally enlarged articulation surface (by 45°) to replace the humeral head. Due to the lateral enlargement of the articulation surface, the Acromion has a 'sliding partner' in abduction and an impingement of the tubercle is prevented. The CTA cap is mounted on a metaphyseal component via a 12/14 taper connection. CTA caps have no eccentricity.

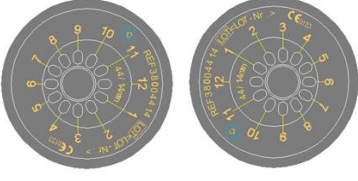

Fig. 6. AGILON® CTA CAP

10.1.3 AGILON® Cap Inverse

A conventional anatomical total shoulder replacement is not as beneficial for patients with large rotator cuff tears who have developed a complex type of shoulder arthritis called "cuff tear arthropathy". For these patients an anatomical total shoulder replacement may result in pain and limited motion, and inverse total shoulder replacement may be an option. In the inverse total shoulder replacement, the socket and the ball are switched. So, the "socket" is attached to the top of the upper arm and the ball is fitted into the shoulder glenoid.

PRODUCT DESCRIPTION

AGILON® SHOULDER SYSTEM

The AGILON® cap inverse is a concave humerus socket that is designed to articulate with a glenosphere (ball) mounted as glenoid component. The inverse cap is available in three different neck lengths (S, M and L) which allows to adjust the humeral offset and can be used to increase the tension of the M. deltoids by a lateralizing effect.



Fig. 7. AGILON® CAP INVERSE

10.1.4 AGILON® Retentive Cap Inverse

The AGILON® retentive cap inverse is a concave humerus socket with increased socket depth for replacement of the humeral head as part of an inverse total shoulder prosthesis. The socket depth is increased by 3 mm and results in an increase in force to dislocate the joint. Due to reduced risk of luxation, AGILON® retentive cap inverse is used in cases of inadequate joint stability. The retentive cap inverse is available in three different neck lengths (S, M and L) which allows to adjust the humeral offset.



Fig. 8. AGILON® RETENTIVE CAP INVERSE

10.2 Glenoid Components

10.2.1 AGILON® Glenoid Cementless Round (Glenoid Baseplate Round)

The AGILON® glenoid cementless round is characterized by a round shape with a conical pin on the backside for cementless anchorage in the bone. It is intended to replace the anatomical glenoid by combination with a glenosphere for an inverse shoulder replacement.

The AGILON® glenoid cementless round is available in two versions – HA coated and uncoated. The uncoated version is named glenoid baseplate.

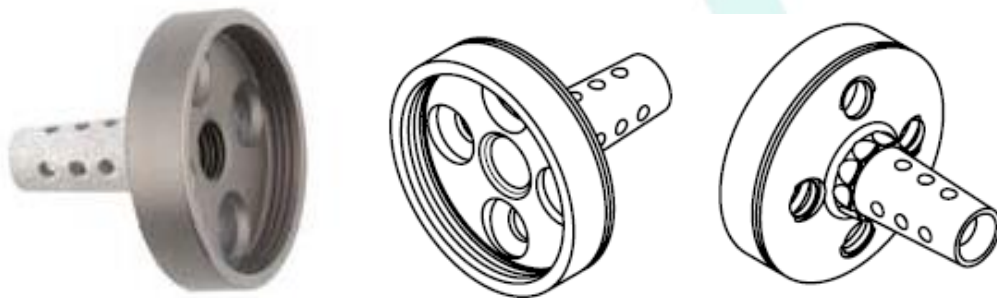

Fig. 9. AGILON® GLENOID CEMENTLESS ROUND

10.2.2. AGILON® Glenoid Cementless Anatomical

The AGILON® glenoid cementless anatomical is characterized by a pear shape with a conical pin on the backside for cementless anchorage in the bone. It is intended to replace the anatomical glenoid by combination with a glenoid PE-insert or a glenosphere for total shoulder replacement (anatomical or inverse). The AGILON® glenoid cementless anatomical is available in two versions – HA coated and uncoated. The uncoated version is named glenoid baseplate

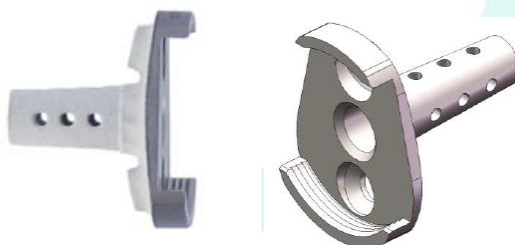

Fig. 10. AGILON® GLENOID CEMENTLESS ANATOMICAL (METAL BACK)

10.2.3. AGILON® Glenoid PE-Insert

The AGILON® glenoid PE-insert is characterized by a pear shape with a conical pin on the backside. It is intended to replace the surface of the anatomical glenoid by combination with an AGILON® glenoid cementless anatomical for total anatomical shoulder replacement. The AGILON® glenoid PE-insert is available in two material versions.



Fig. 11. AGILON® GLENOID PE-INSERT

10.2.4. AGILON® PE-Glenosphere

The AGILON® glenosphere is characterized by a spherically design to replace the glenoid surface in case of an inverse total shoulder arthroplasty. The glenosphere is mounted on an AGILON® glenoid component cementless via a snap-in mechanism. Furthermore, the backside of the glenosphere provides a central pin to enhance stability.

The AGILON® glenosphere is available in two versions – neutral and eccentric design. The eccentric glenospheres decrease the risk of scapula notching, a common complication after reverse shoulder arthroplasty. The inferior overhang of the glenospheres can be selected from 0, 2 or 3 mm. The AGILON® PE-glenosphere is available in two material versions.

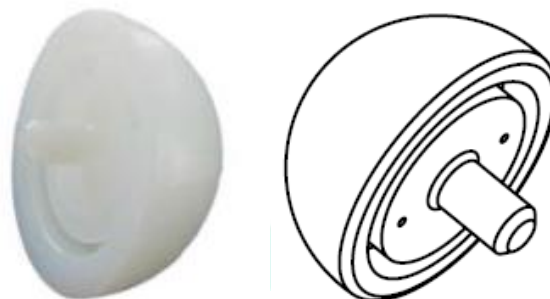

Fig. 12. AGILON® PE-GLENOSPHERE



Fig. 13. AGILON® PE-GLENOSPHERE - ECCENTRICITY PREVENTS SCAULA NOTCHING

10.3 Humeral Components with Extended Fit

10.3.1 AGILON® Screw (REF 382100XX)

The AGILON® screw connects the modular humeral components, consisting of AGILON® stem, if required AGILON® extension piece and AGILON® metaphyseal component.

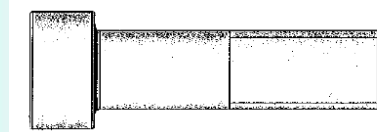

Fig. 14. AGILON® SCREW

10.3.2. AGILON® Extension Piece (REF 38210XXX)

The AGILON® extension piece allows a length extension of the proximal stem from 7.5 mm to 17.5mm in steps of 2.5 mm. This enables an optimized position and alignment of the prosthesis.

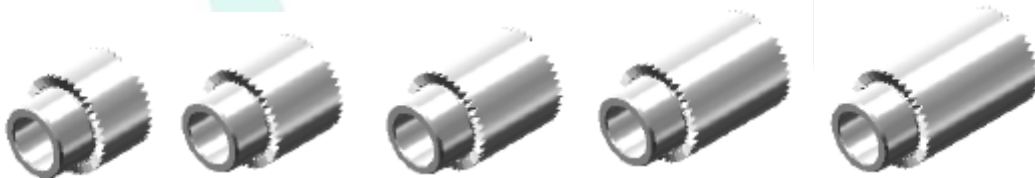

Fig. 15. AGILON® EXTENSION PIECE

10.3.3. AGILON® Metaphyseal Component Trauma (REF 382100XX)

The AGILON® metaphyseal component trauma replaces the metaphyseal part of the humerus in case of a traumatic destroyed shoulder joint (multi-fragment fractures of the humeral head). It enables the fixation of the AGILON® caps, CTA caps, caps inverse and retentive caps inverse on the humeral stem component. The AGILON® metaphyseal component trauma is available in two different inclination

PRODUCT DESCRIPTION

AGILON® SHOULDER SYSTEM

angles (135° and 155°). The tothing on the distal end of the metaphyseal component allows a rotational alignment of 10° steps.

Three proximal ears allow a reposition of bone fragments by using a special suture technique to rebuild the proximal humerus around the metaphyseal part of the prosthesis (Fig.17).



Fig. 16. AGILON® METAPHYSEAL COMPONENT TRAUMA (135° LEFT, 155° RIGHT)

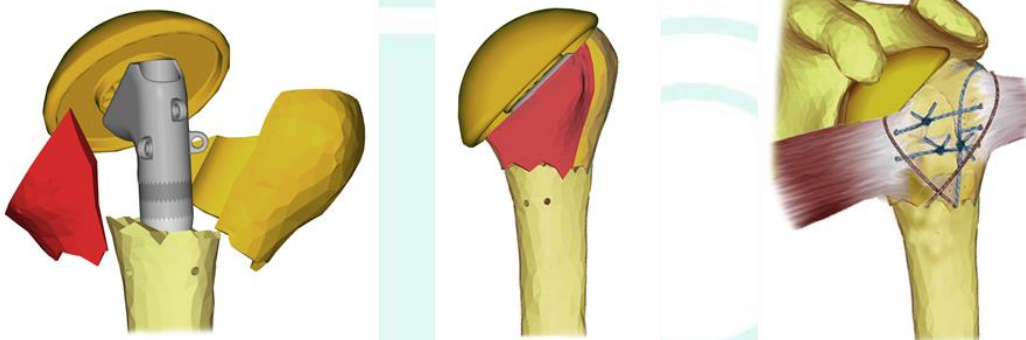

Fig. 17. REBUILD THE PROXIMAL HUMERUS WITH AGILON® METAPHYSEAL COMPONENT TRAUMA

10.3.4. AGILON® Metaphyseal Component Omarthrosis (REF 382100XX)

The AGILON® metaphyseal component omarthrosis replaces the metaphyseal part of the humerus in case of an existing omarthrosis. It enables the fixation of the AGILON® caps, CTA caps, caps inverse and retentive caps inverse on the humeral stem component. The AGILON® metaphyseal component omarthrosis is available in two different inclination angles (135° and 155°) and two different lengths (30 mm and 40 mm). The long version (40mm) is recommend in anatomical use, whereas the short version (30 mm) is recommended in inverse use.

The design of the AGILON® metaphyseal component omarthrosis provides a collar and fins to enhance fixation. The tothing on the distal end of the metaphyseal component allows a rotational alignment of 10° steps.

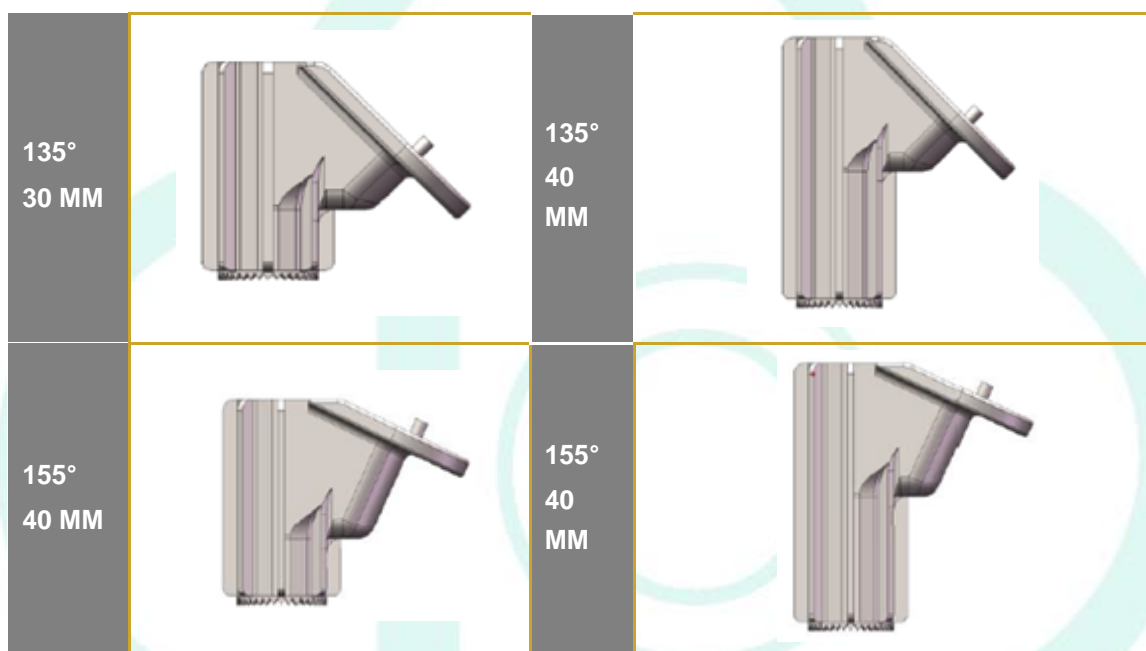

Fig. 18. AGILON® METAPHYSEAL COMPONENT OMARTHROSIS

10.3.5 AGILON® Stem Cementless (REF 385XXXXX)

The AGILON® stems cementless offer the possibility of a cementless fixation in the humerus. The stems are available in a variety of diameters and lengths. The basic shape of the stem (without fins) provides a constant cross section. Due to the fins, the stem has a conical shape in the proximal stem region. The conicity (6°) comes about the different heights of the fins. Though conicity, a safe anchorage of the stem is achieved (press-fit).

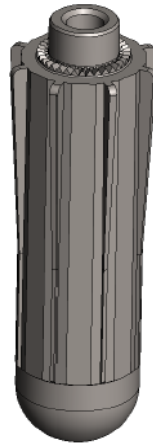

Fig. 19. AGILON® STEM CEMENTLESS

10.3.6. AGILON® Stem Cemented (REF 384XXXXX)

The AGILON® stems cemented are for cemented application only. The stems are available in a variety of diameters and lengths. The stem has a cylindrical constant cross section and has three longitudinal grooves for rotational stability. It is tapered in the proximal region and is designed with a round profile.

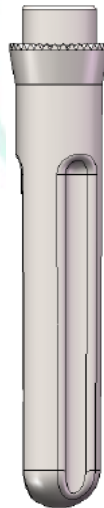

Fig. 20. AGILON® STEM CEMENTED

10.4. Humeral Components Without Extended Fit

10.4.1. AGILON® Screw (REF 382000XX)

The AGILON® screw connects the modular humeral components, consisting of AGILON® stem, if required AGILON® extension piece and AGILON® metaphyseal component.



Fig. 21. AGILON® SCREW

10.4.2. AGILON® Extension Piece (REF 38200XXX)

The AGILON® extension pieces allow an extension of the proximal stem from 5 mm to 17.5 mm in steps of 2.5 mm. The extension of the stem is reached by one or a combination of up to two AGILON® extension pieces. This enables an optimized position and alignment of the prosthesis.



Fig. 22. AGILON® EXTENSION PIECES

10.4.3. AGILON® Metaphyseal Component Trauma (REF 38200001)

The AGILON® metaphyseal component trauma replaces the metaphyseal part of the humerus in case of a traumatic destroyed shoulder joint (multi-fragment fractures of the humeral head). It enables the fixation of the AGILON® caps, CTA caps, caps inverse and retentive caps inverse on the humeral stem component. The AGILON® metaphyseal component trauma is available with an inclination angles of 135°. The tothing on the distal end of the metaphyseal component allows a rotational alignment of 10° steps.

Three proximal ears allow a reposition of bone fragments by using a special suture technique to rebuild the proximal humerus around the metaphyseal part of the prosthesis (Fig. 24).



Fig. 23. AGILON® METAPHYSEAL COMPONENT TRAUMA

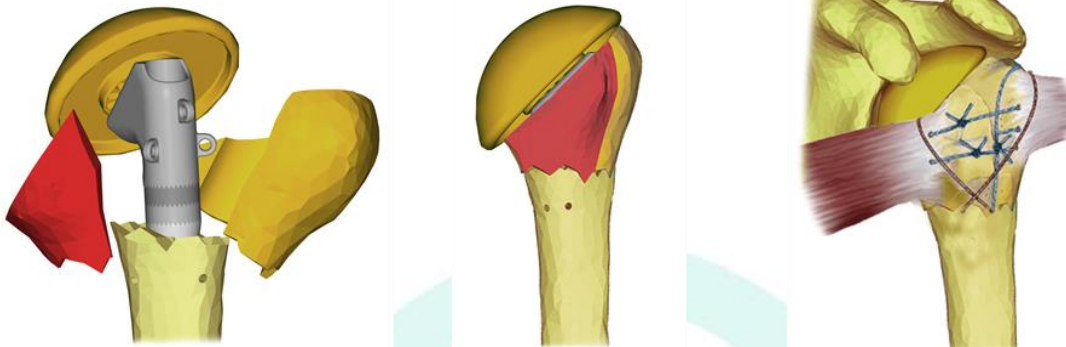

Fig. 24. REBUILD THE PROXIMAL HUMERUS WITH AGILON® METAPHYSEAL COMPONENT TRAUMA

10.4.4. AGILON® Metaphyseal Component Primary (3820000X)

The AGILON® metaphyseal component primary replaces the metaphyseal part of the humerus in case of an existing omarthrosis. It enables the fixation of the AGILON® caps, CTA caps, caps inverse and retentive caps inverse on the humeral stem component. The AGILON® metaphyseal component omarthrosis is available in one size with an inclination angles of 135° and two different lengths (30 mm and 40 mm). The long version (40mm) is recommend in anatomical use, whereas the short version (30 mm) is recommended in inverse use.

The design of the AGILON® metaphyseal component omarthrosis provides a collar and fins to enhance fixation. The tothing on the distal end of the metaphyseal component allows a rotational alignment of 10° steps.



Fig. 25. AGILON® METAPHYSEAL COMPONENT PRIMARY

10.4.5. AGILON® Stem Cementless (REF 383XXXXX)

The AGILON® stems cementless offer the possibility of a cementless fixation in the humerus. The stems are available in a variety of diameters and lengths. The basic shape of the stem (without fins) provides a constant cross section. Due to the fins, the stem has a conical shape in the proximal stem region. The conicity (6°) comes about the different heights of the fins. Though conicity, a safe anchorage of the stem is achieved (press-fit).



Fig. 26. AGILON® STEM CEMENTLESS

10.4.6. AGILON® Stem Cemented (REF 382XXXXX)

The AGILON® stems cemented are for cemented application only. The stems are available in a variety of diameters and lengths. The stem has a cylindrical constant cross section and has three longitudinal grooves for rotational stability. It is taped in the proximal region and is designed with a round profile.



Fig. 27. AGILON® STEM CEMENTED

10.4.7. Safety Screw (REF 38200101)

The safety screw provides an additional safety of the AGILON® screws against loosening. The AGILON® metaphyseal components have a thread to access the safety screw. The safety screw is only available in one size



Fig. 28. SAFETY SCREW

10.5 Metaphyseal Implant

10.5.1. AGILON® MI

The modular AGILON® shoulder system was complemented by the stemless metaphyseal implant. The components of the AGILON® MI are made of additive manufactured EPORE® structure (TiAl6V4) and are available in 5 sizes. The highly porous stem is designed with conical 4 fins. A proximal collar rests on the resected bone surface. All anatomical AGILON® caps and CTA caps can be combined with the MI components.



Fig. 29:AGILON® MI



Fig. 30. AGILON® MI – PROXIMAL VIEW (LEFT), DISTAL VIEW (CENTRE) AND SIDE VIEW (RIGHT)

11. Materials

The AGILON® Cap, AGILON® CTA Cap, AGILON® Cap Inverse and AGILON® Retentive Cap Inverse are manufactured from TiAl6V4 acc. to ISO 5832-3.

The AGILON® Glenoid Cementless Round, AGILON® Glenoid Baseplate Round, AGILON® Glenoid Cementless Anatomical and AGILON® Glenoid Baseplate Cementless Anatomical are manufactured from pure titanium (cpTi) acc. to ISO 5832-2.

The AGILON® Glenoid PE insert implacross® E, AGILON® PE-Glenoid implacross® E Cemented and AGILON® PE-Glenosphere implacross® E are manufactured from crosslinked UHMWPE with vitamin E.

The AGILON® PE-Glenosphere, AGILON® PE-Glenoid Cemented and AGILON® Glenoid PE-Insert are manufactured from UHMW-PE acc. to ISO 5834-2.

The AGILON® Screw is manufactured from CoCrMo acc. to ISO 5832-12.

The AGILON® Extension Piece, AGILON® Metaphyseal Component Trauma, AGILON® Metaphyseal Component Primary, AGILON® Metaphyseal Component Omarthrosis, AGILON® Stem Cementless and Safety Screw are manufactured from TiAl6V4 acc. to ISO 5832-3.

The AGILON® Stem Cemented is manufactured from CoCrMo acc. to ISO 5832-4.

The AGILON® MI is manufactured from TiAl6V4.

12. Coatings / Surfaces

12.1 Caps

AGILON® Cap, AGILON® CTA Cap, AGILON® Cap Inverse and AGILON® Retentive Cap Inverse

All AGILON® Caps provide a Titanium Nitride (TiN) coating, whereas the taper is uncoated and has circular grooves. The articulation surface of the caps has a roughness Ra of 0.05 µm and a roundness of 0.1. The non-articulating surface has a roughness Rz of 4µm and the taper Rz of 6+14 µm.



Fig. 31 AGILON® CAPS

CHARACTERISTICS	VALUE
	TiN (Surface Specification SUR_A1)
COATING PROCESS	PVD-Arc
COATING THICKNESS	5.5 ± 1.5 µm
COATING HARDNESS	2400 ± 400 HV
AVERAGE ROUGHNESS RA	< 0.05 µm
TENSILE STRENGTH	≥ 22 MPa
ADHESIVE STRENGTH ROCKWELL C	0 - 1
ADHESIVE STRENGTH MANDREL BENDING TEST	No layer delamination

TABLE 2 AGILON® CAPS- COATING SPECIFICATIONS FOR TiN

12.2 Glenoid Components

AGILON® glenoid cementless round, AGILON® /glenoid baseplate round, AGILON® glenoid cementless anatomical and AGILON® glenoid baseplate cementless anatomical

The AGILON® glenoid cementless round and AGILON® glenoid cementless anatomical are available in two versions HA coated and uncoated (named glenoid baseplate). Both coated glenoids have a porous, corundum blasted surface on the posterior bone opposing side and provide a Hydroxyapatite (HA) coating that complies with ISO 13779 requirements.



Fig. 32 AGILON® GLENOID CEMENTLESS ROUND



Fig. 33 AGILON® GLENOID CEMENTLESS ANATOMICAL (METAL BACK)

CHARACTERISTICS	VALUE
	HA (Surface Specification SUR_B3)
COATING THICKNESS	90 ± 30 µm
POROSITY	≤ 30%
AVERAGE ROUGHNESS RA	8 ± 3 µm
AVERAGE ROUGHNESS RT	50 ± 20 µm
TENSILE STRENGTH	≥ 15 MPa
SHEAR STRENGTH	≥ 20 MPa

TABLE 3: GLENOID CEMENTLESS ROUND / ANATOMICAL- COATING SPECIFICATION FOR HA

AGILON® Glenoid PE insert

The Glenoid PE insert has a roundness of 0.1 µm and an articulation surface of Ra 2 µm. The Glenoid PE insert is uncoated.

AGILON® PE-Glenosphere

The AGILON® PE glenosphere has a sphericity of 0.1 µm and a roughness Ra of 2 µm. The Glenoid PE insert is uncoated.

12.3 Humeral Components

AGILON® Screw

The AGILON® screw has a sandblasted surface and is completely Titanium Nitride (TiN) coated.



Fig. 34. AGILON® SCREW

CHARACTERISTICS	VALUE
	TiN (Surface Specification SUR_A1)
COATING PROCESS	PVD-Arc
COATING THICKNESS	5.5 ± 1.5 µm
COATING HARDNESS	2400 ± 400 HV
AVERAGE ROUGHNESS RA	< 0.05 µm
TENSILE STRENGTH	≥ 22 MPa
ADHESIVE STRENGTH ROCKWELL C	0 - 1
ADHESIVE STRENGTH MANDREL BENDING TEST	No layer delamination

TABLE 4: COATING SPECIFICATION FOR TiN

AGILON® Extension Piece

The AGILON® extension piece has a sandblasted surface and is uncoated.

AGILON® metaphyseal Component trauma and AGILON® metaphyseal component omarthrosis

The AGILON® metaphyseal components have a sandblasted surface and are uncoated.

AGILON® stem cementless

The AGILON® stems cementless is uncoated and at the distal end, the stem tip is rounded and highly polished (Ra 0.1). The remaining surface is corundum blasted.

AGILON® stem cemented

The AGILON® stems cemented are available uncoated and with a Titanium Nitride (TiN) coating that is applied circumferentially on the stem. These stems have a matt surface and at the distal end, the stem tip is rounded. The remaining surface is sandblasted.



Fig. 35. AGILON® STEM CEMENTED

Safety screw

The safety screw is uncoated and has a sandblasted surface.



Fig. 36.SAFETY SCREW

12.4 Metaphyseal Implant

AGILON® MI

The AGILON® MI is uncoated and provide an EPORE® structure. The EPORE® structure has a high porosity and a low modulus of elasticity so it can enhance biological ingrowth the structure is characterized by rods of 330-390µm thickness which are arrayed in a way that resembles cancellous bone structures

CHARACTERISTICS	VALUE
	EPORE® <i>(Surface Specification G1)</i>
MANUFACTURING PROCESS	Additive Manufacturing
POROSITY	61% ± 8%
SPECIFIC E-MODULE	3.1 GPa ± 0.6 GPa
ROD DIAMETER	360 µm ± 50 µm
COATING THICKNESS	/
TENSILE STRENGTH	/
PHASE COMPOSITION ACC. TO FTIR	/

TABLE 5 EPORE® SPECIFICATION

13. Sizes and Dimensions

13.1. Caps

AGILON® Cap

AGILON® caps are available in 15 sizes ranging from 41 to 53 mm in diameter and 14 to 20 mm in height. To have the closest reconstruction of the anatomical circumstances and to optimize the alignment of the prosthesis there is the choice between 5 different cap diameters (41 mm, 44 mm, 47 mm, 50mm and 53 mm) with respectively 3 different heights (14 mm, 17 mm, 20 mm).

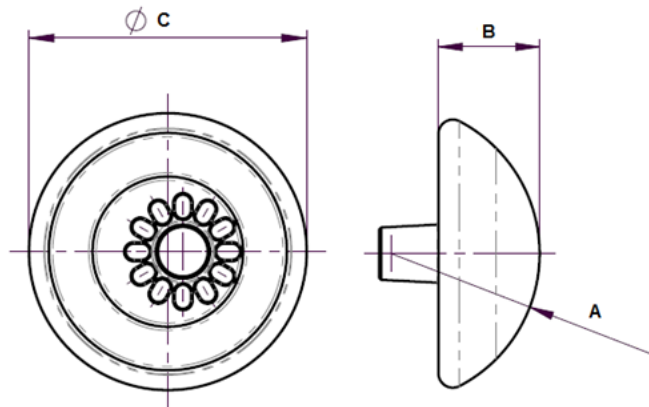

Fig. 37. AGILON® CAP DIMENSIONS

SIZE	41/14	41/17	41/20	44/14	44/17	44/20	47/14	47/17	47/20
RADIUS OF CURVATURE A [MM]	20,6	20,6	20,6	22	22	22	23,5	23,5	23,5
CALOTTE HEIGHT B [MM]	14	17	20	14	17	20	14	17	20
DIAMETER C [MM]	36,9	39,4	40,7	38,6	41,5	43,2	40,3	43,5	45,6
SIZE	50/14	50/17	50/20	53/14	53/17	53/20			
RADIUS OF CURVATURE A [MM]	25	25	25	26,5	26,5	26,5			
CALOTTE HEIGHT B [MM]	14	17	20	14	17	20			
DIAMETER C [MM]	42	45,4	47,8	43,5	47,3	50			

TABLE 6: SIZES AND DIMENSIONS AGILON® CAP

AGILON® CTA Cap

AGILON® CTA caps are available in 12 sizes ranging from 44 to 53 mm in diameter and 14 to 20 mm in height. To have the closest reconstruction of the anatomical circumstances and to optimize the alignment of the prosthesis there is the choice between 4 different cap diameters (44 mm, 47 mm, 50mm and 53 mm) with respectively 3 different heights (14 mm, 17 mm, 20 mm).

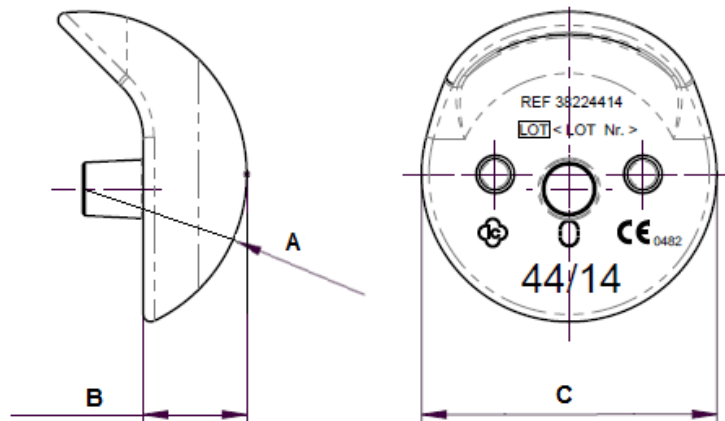

Fig. 38. AGILON® CTA CAP DIMENSIONS

SIZE	44/14	44/17	44/20	47/14	47/17	47/20	50/14	50/17	50/20	53/14	53/17	53/20
RADIUS OF CURVATURE A [MM]	22	22	22	23,5	23,5	23,5	25	25	25	26,5	26,5	26,5
CALOTTE HEIGHT B [MM]	14	17	20	14	17	20	14	17	20	14	17	20
DIAMETER C [MM]	39,95	42,25	43,57	41,80	44,43	46,09	43,57	46,50	48,44	45,27	48,48	50,74

TABLE 7: SIZES AND DIMENSIONS AGILON® CTA CAP

AGILON® Cap Inverse

The AGILON® cap inverse is available in 12 sizes ranging from 32 to 44 mm in diameter (32 mm, 36 mm, 40 mm, and 44 mm) with respectively three different heights (20 mm, 23 mm, 26 mm).

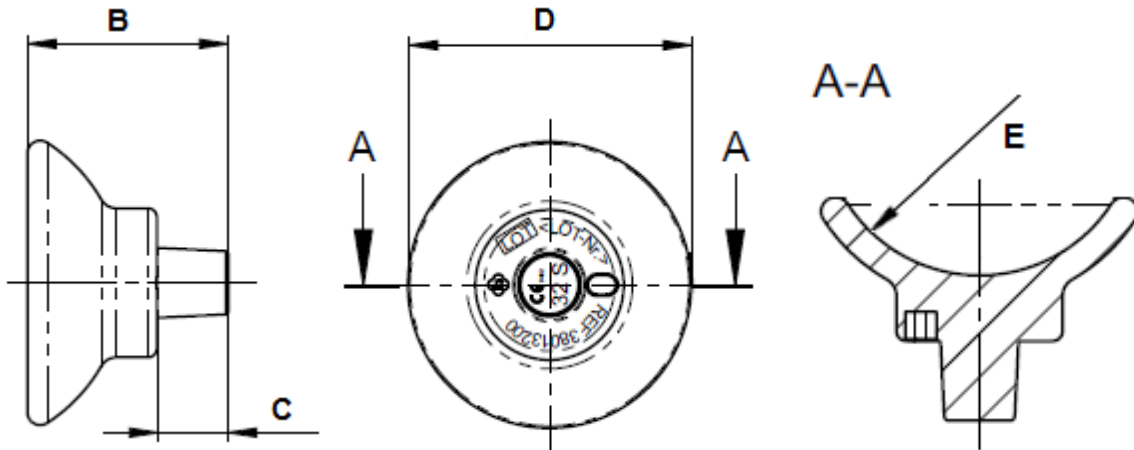

Fig. 39. AGILON® CAP INVERSE DIMENSIONS

SIZE	32 S	32 M	32 L	36 S	36 M	36 L	40 S	40 M	40 L	44 S	44 M	44 L
DIAMETER D [MM]	32,4	32,4	32,4	34,5	34,5	34,5	36,5	36,5	36,5	38,4	38,4	38,4
RADIUS OF CURVATURE E [MM]	16	16	16	18	18	18	20	20	20	22	22	22
HEIGHT (WITH CONE) B [MM]	20	23	26	20	23	26	20	23	26	20	23	26
HEIGHT (WITHOUT CONE) [MM]	12	15	18	12	15	18	12	15	18	12	15	18
LENGHT CONE C [MM]	8	8	8	8	8	8	8	8	8	8	8	8

TABLE 8: SIZES AND DIMENSIONS AGILON® CAP INVERSE

The different neck lengths of the AGILON® cap inverse (S, M, and L) allow to adjust the humeral offset between 0 mm, 3 mm and 6 mm (Fig. 11).

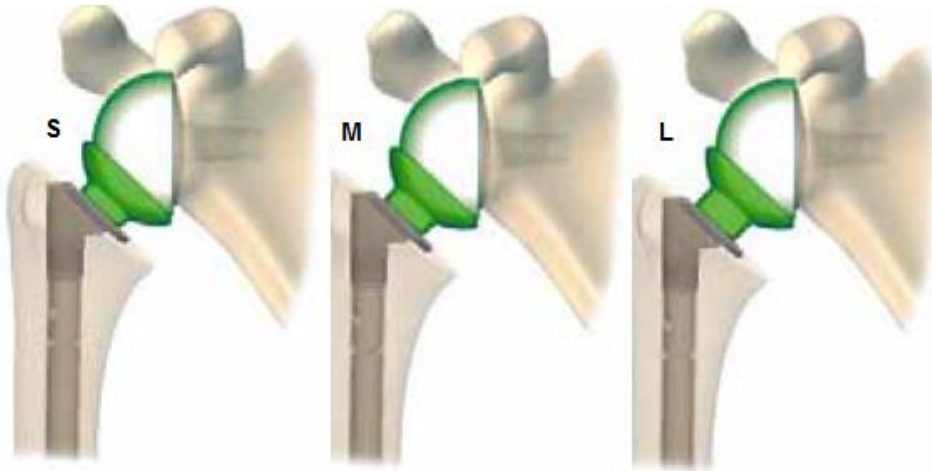

Fig. 40. AGILON® CAP INVERSE WITH DIFFERENT NECK LENGTHS (S, M, L)

AGILON® Retentive Cap Inverse

The AGILON® retentive cap inverse is available in 12 sizes ranging from 32 to 44 mm in diameter (32 mm, 36 mm, 40 mm, and 44 mm) with respectively three different heights (23 mm, 26 mm, 29 mm).

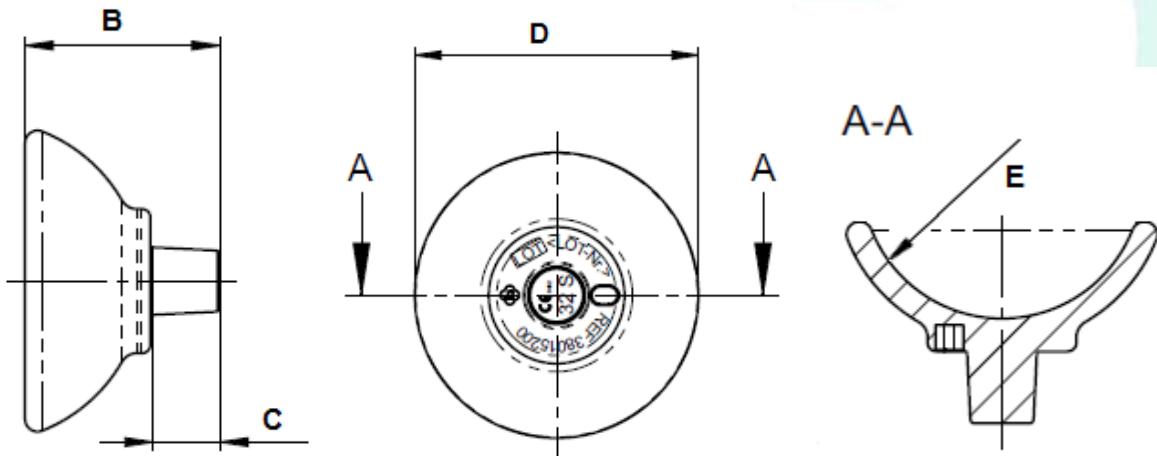

Fig. 41. AGILON® RETENTIVE CAP INVERSE DIMENSIONS

SIZE	32 S	32 M	32 L	36 S	36 M	36 L	40 S	40 M	40 L	44 S	44 M	44 L
DIAMETER D [MM]	35,5	35,5	35,5	38,1	38,1	38,1	40,6	40,6	40,6	42,8	42,8	42,8
RADIUS OF CURVATURE E [MM]	16	16	16	18	18	18	20	20	20	22	22	22
HEIGHT (WITH CONE) B [MM]	20	23	26	20	23	26	20	23	26	20	23	26
HEIGHT (WITHOUT CONE) [MM]	12	15	18	12	15	18	12	15	18	12	15	18
LENGHT CONE C [MM]	8	8	8	8	8	8	8	8	8	8	8	8

TABLE 9: SIZES AND DIMENSIONS AGILON® RETENTIVE CAP INVERSE

13.2 Glenoid Components

AGILON® Glenoid Cementless Round

AGILON® glenoid cementless round is available in one size.

SIZE	Length [mm]	Length of the pin [mm]	Diameter [mm]	Inner snap diameter [mm]
1	26,55	14	24,95	20,82

TABLE 10: SIZES AND DIMENSIONS AGILON® GLENOID CEMENTLESS ROUND

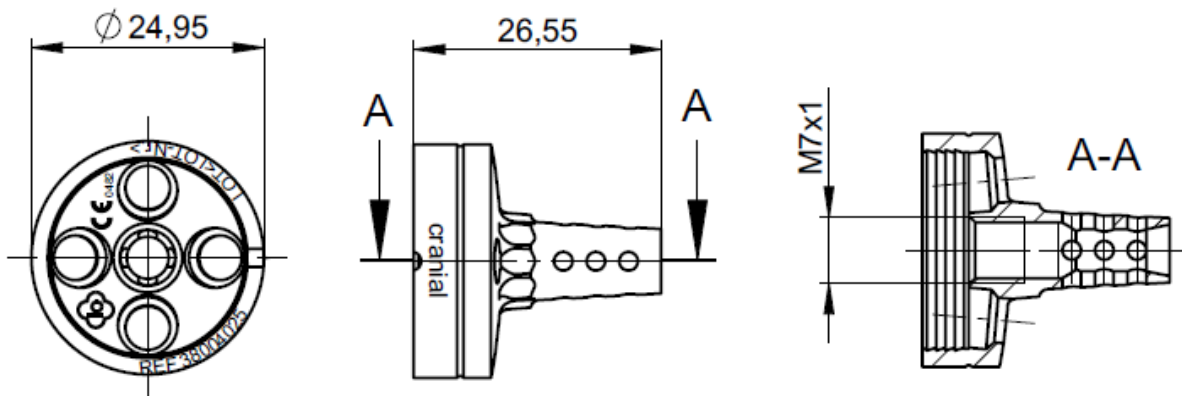

Fig. 42. AGILON® GLENOID CEMENTLESS ROUND SIZE 1

AGILON® Glenoid Cementless Anatomical

The AGILON® glenoid cementless anatomical is available in 4 sizes (two diameter each with a short and a long pin).

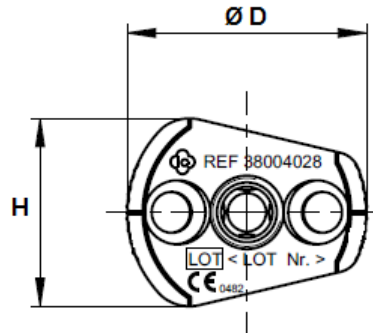

Fig. 43. AGILON® GLENOID CEMENTLESS ANATOMICAL DIMENSIONS

SIZE	Height H [mm]	Ø Diameter D [mm]	Length [mm]	Length of the pin [mm]
2 SHORT	22	27.95	L1 = 24	14
2 LONG	22	27.95	L1 = 29	19
3 SHORT	25	31.95	L2 = 27	17
3 LONG	25	31.95	L2 = 32	22

TABLE 11: SIZES AND DIMENSIONS AGILON® GLENOID CEMENTLESS ANATOMICAL

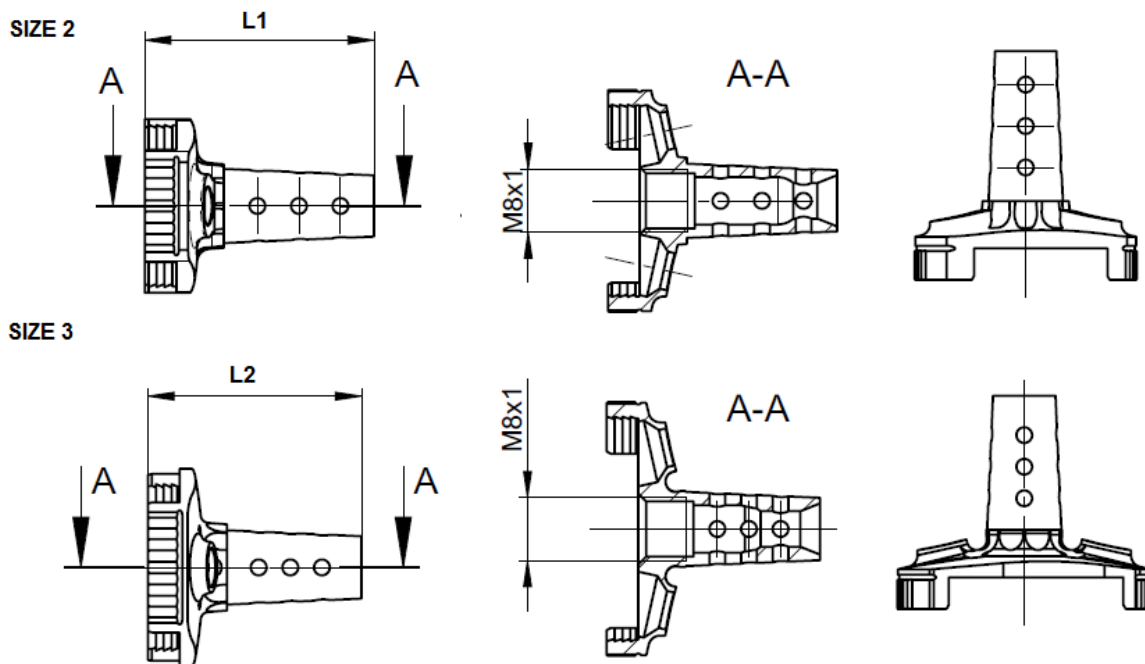

Fig. 44. AGILON® GLENOID CEMENTLESS ANATOMICAL DIMENSIONS (SIZE 2 AND SIZE3)

AGILON® Glenoid PE Insert

AGILON® glenoid PE-insert is available in 3 sizes (2, 3 and 4).

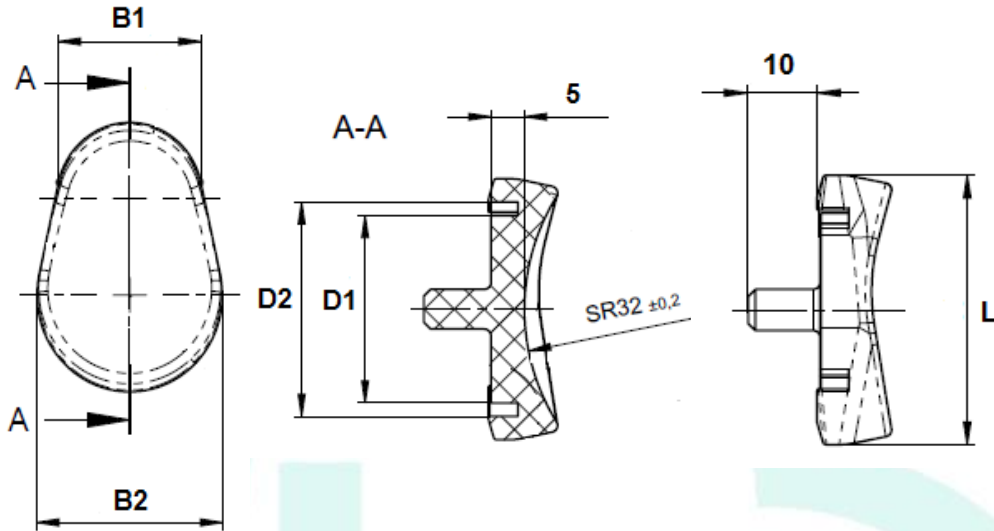

Fig. 45. AGILON® GLENOID PE-INSERT DIMENSIONS

SIZE	Top width B1 [mm]	Bottom width B2 [mm]	Diameter D1 [mm]	Diameter D2 [mm]	Length L [mm]	Radius of curvature [mm]
2	15.76	22.6	24	28.05	33	32
3	18.37	25.06	28	32.05	37	32
4	21.5	28	28	32.05	39	32

TABLE 12: SIZES AND DIMENSIONS AGILON® GLENOID PE-INSERT

AGILON® PE-Glenosphere

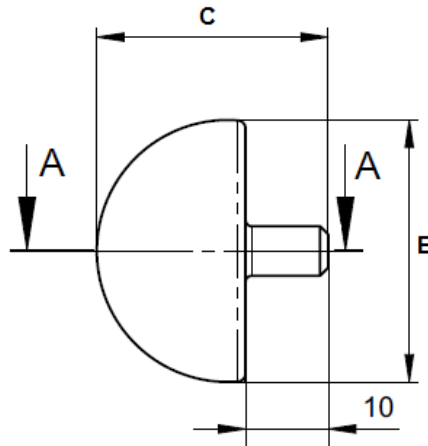

Fig. 46. AGILON® PE-GLENOSPHERE DIMENSIONS

SIZE	Version	Width B [mm]	Length C [mm]	Diameter D1[mm]	Diameter D2 [mm]	Eccentricity E [mm]
1, 32 MM	neutral	31.6	28	21	25.05	0
1, 36 MM	eccentric	35.6	30	21	25.05	2
2, 32 MM	neutral	31.6	28	24	28.05	0
2, 36 MM	eccentric	35.6	30	24	28.05	2
2, 40 MM	eccentric	39.6	32	24	28.05	2
2, 44 MM	eccentric	43.6	34	24	28.05	3
3, 36 MM	neutral	35.6	30	28	32.05	0
3, 40 MM	eccentric	39.6	32	28	32.05	2
3, 44 MM	eccentric	43.6	34	28	32.05	3

TABLE 13: SIZES AND DIMENSIONS AGILON® PE-GLENOSPHERE

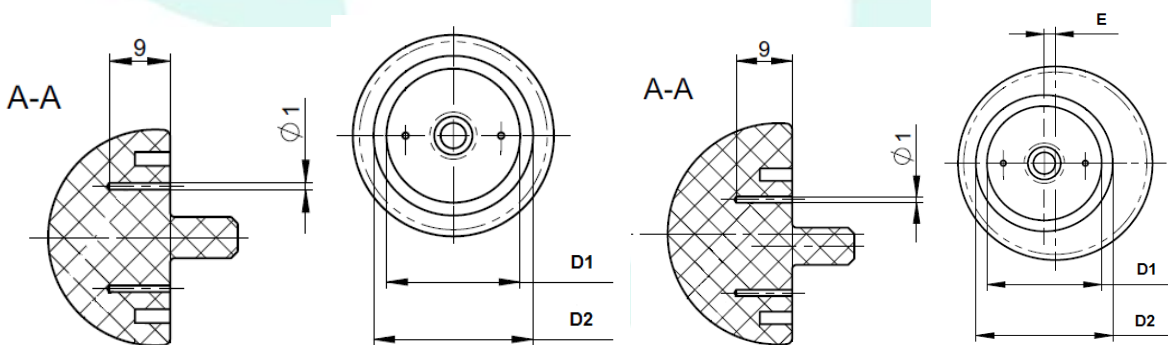

Fig. 47. AGILON® PE-GLENOSPHERE DIMENSIONS – NEUTRAL (LEFT) AND ECCENTRIC (RIGHT)

13.3 Humeral Components with Extended Fit

AGILON® Screw (REF 382100XX)

AGILON® screw is available in 6 sizes ranging from 22.5 to 40 mm in length (22.5 mm, 30 mm, 32.5 mm, 35 mm, 37.5 mm, and 40 mm).

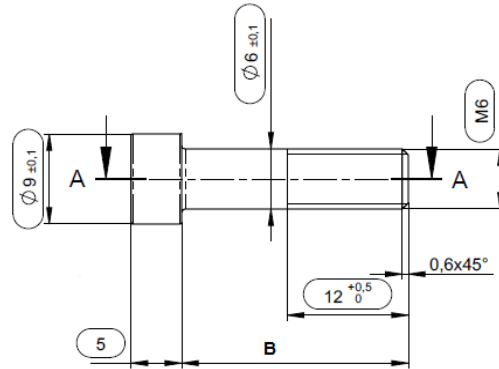

Fig. 48. AGILON® SCREW DIMENSIONS

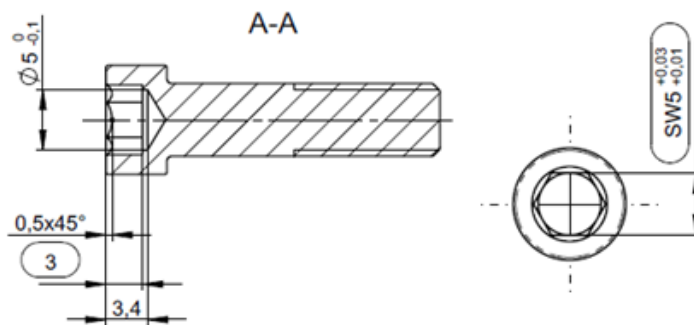

Fig. 49. AGILON® SCREW DIMENSIONS (2)

SIZE	M6 x 22,5	M6 x 30	M6 x 32,5	M6 x 35	M6 x 37,5	M6 x 40
THREAD	M6	M6	M6	M6	M6	M6
SCREW LENGTH B [MM]	22,5	30	32,5	35	37,5	40
THREAD LENGTH [MM]	12	12	12	12	12	12

TABLE 14: SIZES AND DIMENSIONS AGILON® SCREW

AGILON® Extension Piece (REF 38210XXX)

AGILON® extension piece is available in 5 sizes ranging from 7.5 to 17.5 mm in length (7.5 mm, 10 mm, 12.5 mm, 15 mm, and 17.5 mm).

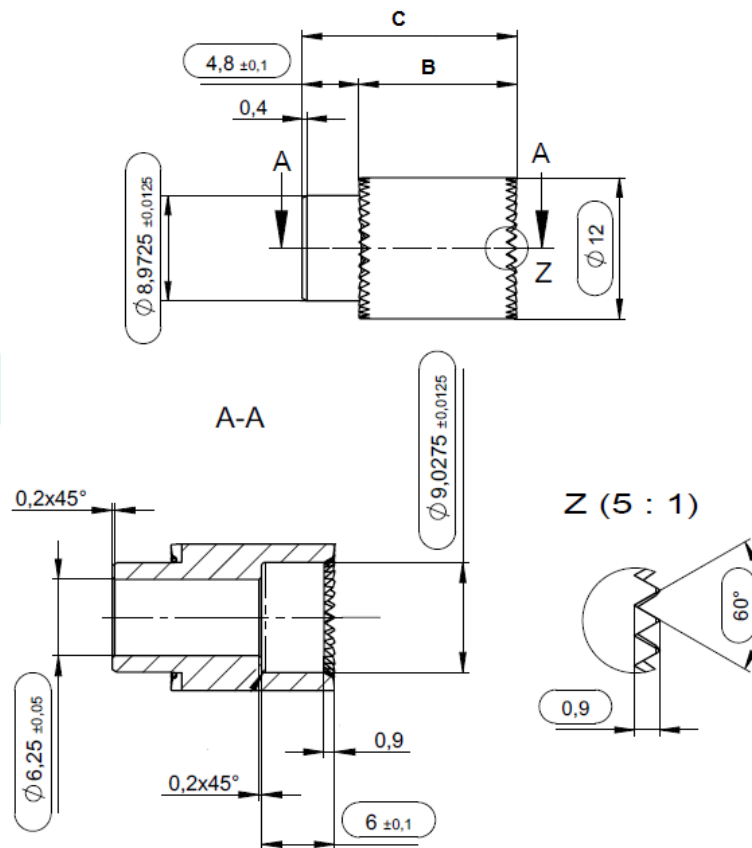

Fig. 50. AGILON® EXTENSION PIECE DIMENSIONS

SIZE	7,5	10	12,5	15	17,5
LENGTH B (WITHOUT FITTING) [MM]	8,4	10,9	13,4	15,9	18,4
LENGTH C (WITH FITTING) [MM]	13,2	15,7	18,2	20,7	23,2
LENGTH OF THE OUTER FITTING [MM]	4,8	4,8	4,8	4,8	4,8
LENGTH OF THE INNER FITTING [MM]	6	6	6	6	6

TABLE 15: SIZES AND DIMENSIONS AGILON® EXTENSION PIECE

PRODUCT DESCRIPTION

AGILON® SHOULDER SYSTEM

AGILON® Metaphyseal component trauma (REF 382100XX)

The AGILON® metaphyseal component trauma is available in two different inclination angles (135° and 155°).

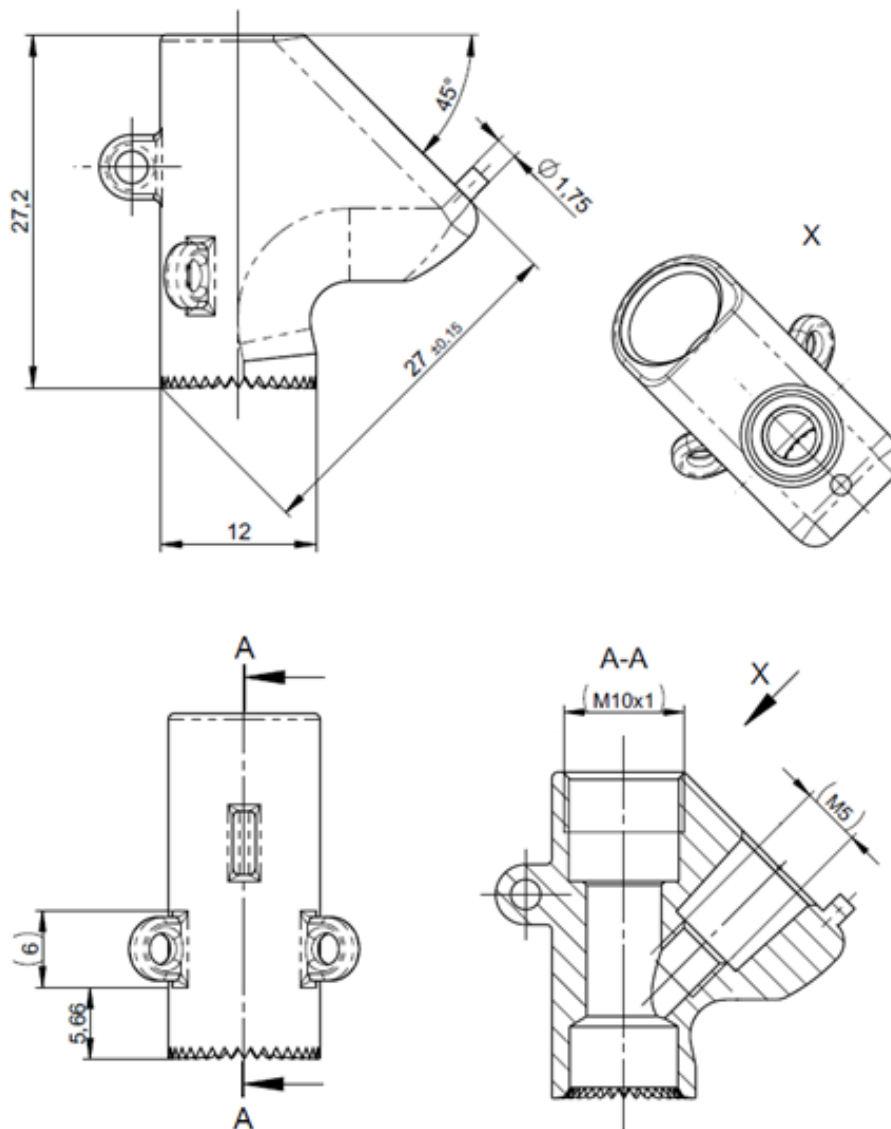

Fig. 51 AGILON® METAPHYSEAL COMPONENT TRAUMA (135°) DIMENSIONS

PRODUCT DESCRIPTION

AGILON® SHOULDER SYSTEM

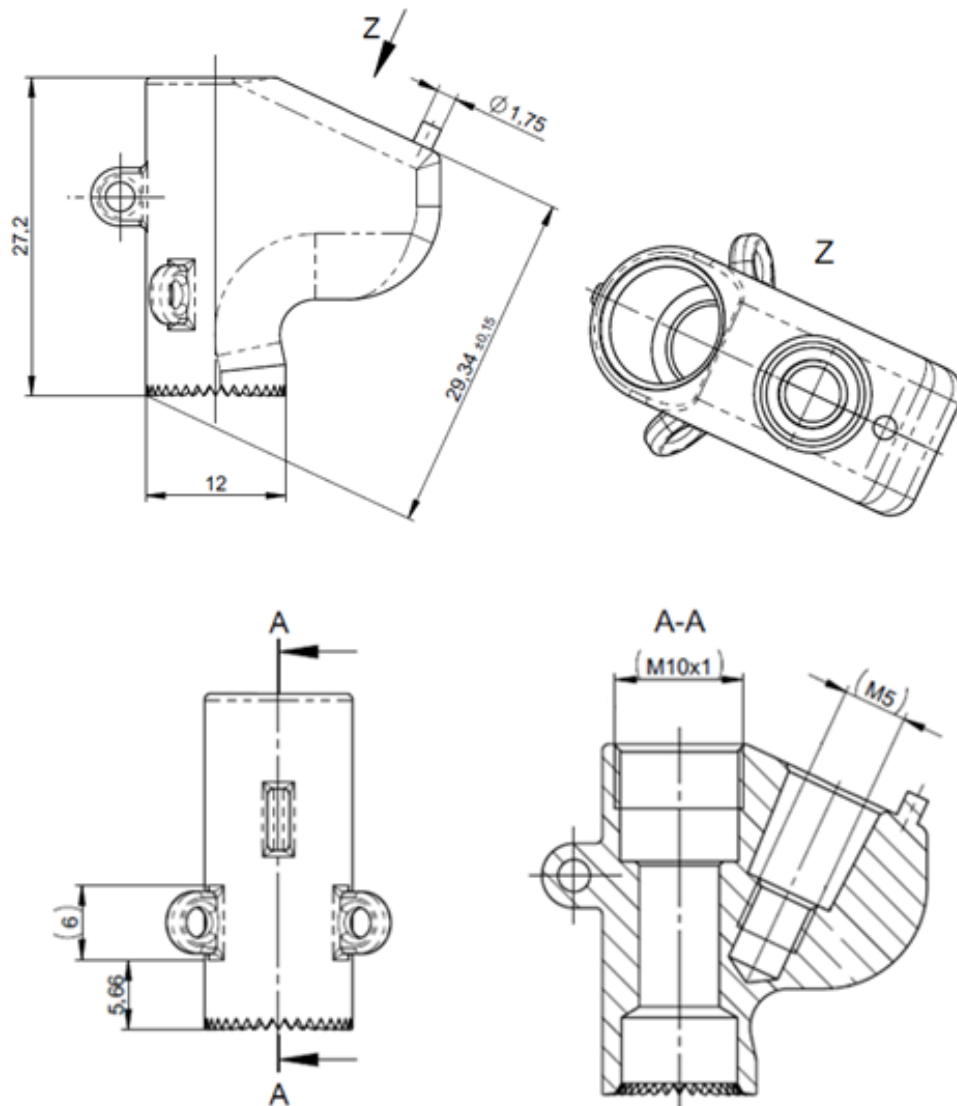

Fig. 52. AGILON® METAPHYSEAL COMPONENT TRAUMA (155°) DIMENSIONS

AGILON® Metaphyseal Component Omarthrose (REF 382100XX)

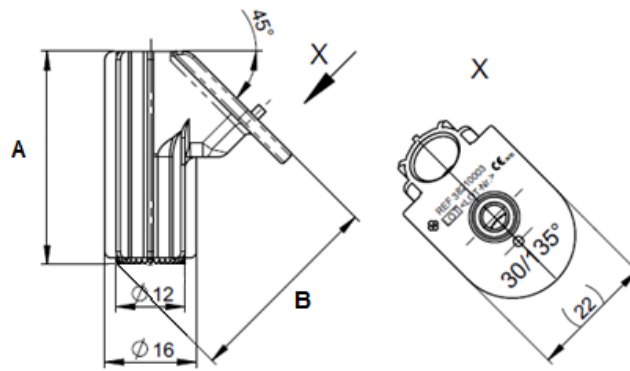

Fig. 53 AGILON® METAPHYSEAL COMPONENT OMARTHROSIS (135°) DIMENSIONS

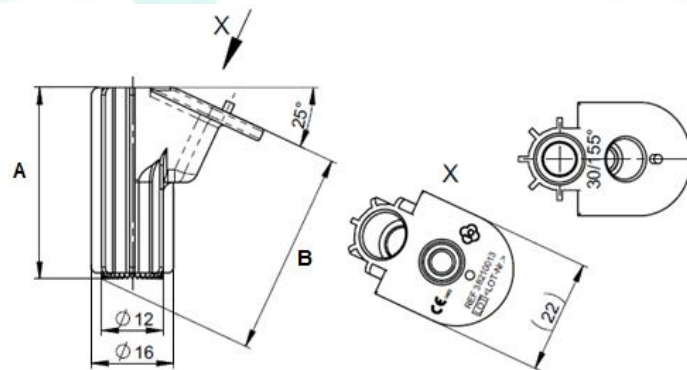

Fig. 54. AGILON® METAPHYSEAL COMPONENT OMARTHROSIS (155°) DIMENSIONS

METAPHYSEAL COMPONENT OMARTHROSIS	Inclination angle	Length A [mm]	Length B [mm]
135° 30 MM	135°	27,2	28,25
135° 40 MM	135°	37,2	35,35
155° 30 MM	155°	27,2	30,61
155° 40 MM	155°	37,2	39,67

TABLE 16: SIZES AND DIMENSIONS AGILON® METAPHYSEAL COMPONENT OMARTHROSIS

PRODUCT DESCRIPTION

AGILON® SHOULDER SYSTEM

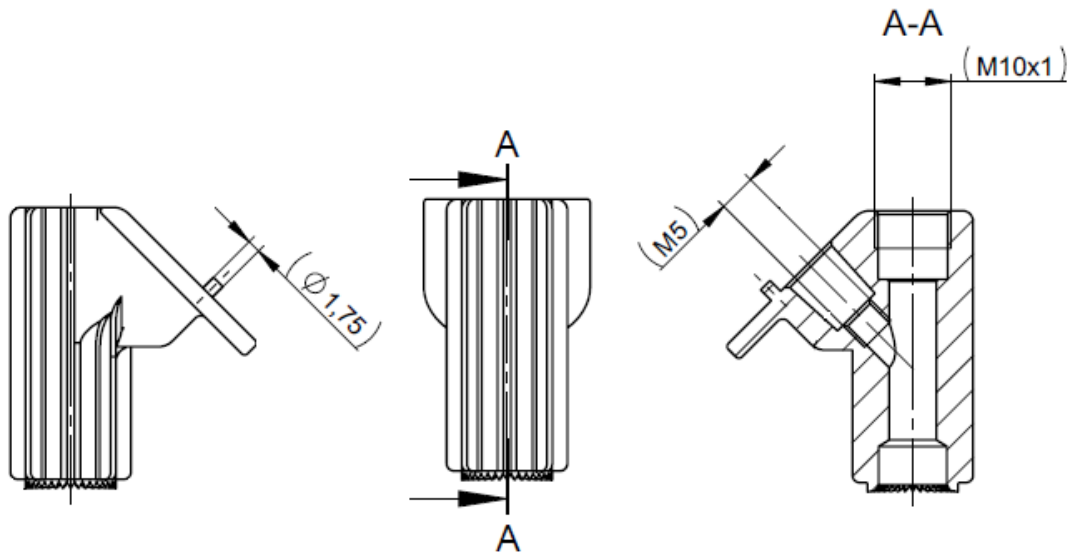

Fig. 55. AGILON® METAPHYSEAL COMPONENT OMARTHROSIS (135°) DIMENSIONS

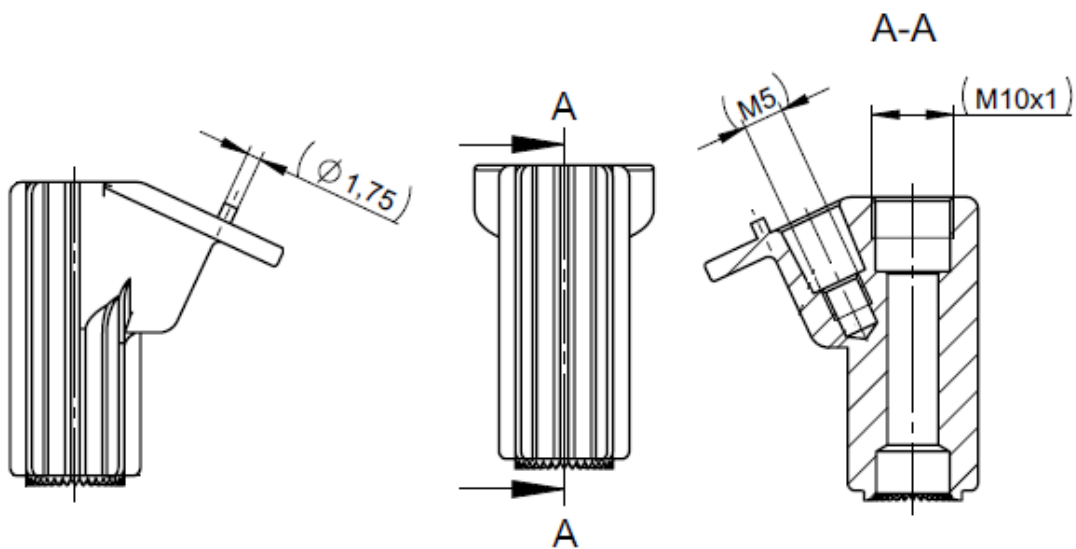

Fig. 56. AGILON® METAPHYSEAL COMPONENT OMARTHROSIS (155°) DIMENSIONS

AGILON® Stem Cementless

The AGILON® stem cementless is available in 43 sizes ranging from 30 to 240 mm in length (30 mm, 60 mm, 120 mm, 180 mm, and 240 mm) and up to 9 different diameters. AGILON® stems cementless 180 and 240 mm in length are provided for complex fractures or revision arthroplasties.

LENGTH [MM]	DIAMETER [MM]									
	9	10	11	12	13	14	15	16	17	18
30		x	x	x	x	x	x	x	x	x
60	x	x	x	x	x	x	x	x	X	x
120	x	x	x	x	x	x	x	X		
180	x	x	x	x	x	x	x	X		
240	x	x	x	x	x	x	x	x		

TABLE 17: SIZES AGILON® STEM CEMENTLESS

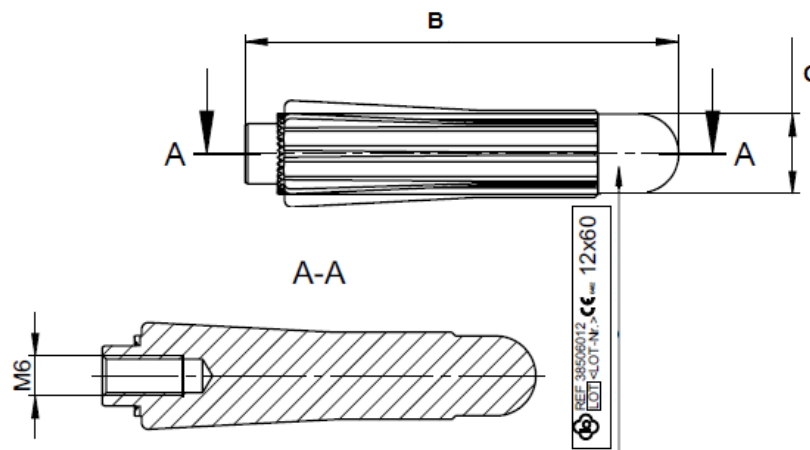

Fig. 57. AGILON® STEM CEMENTLESS 30 MM TO 120 MM

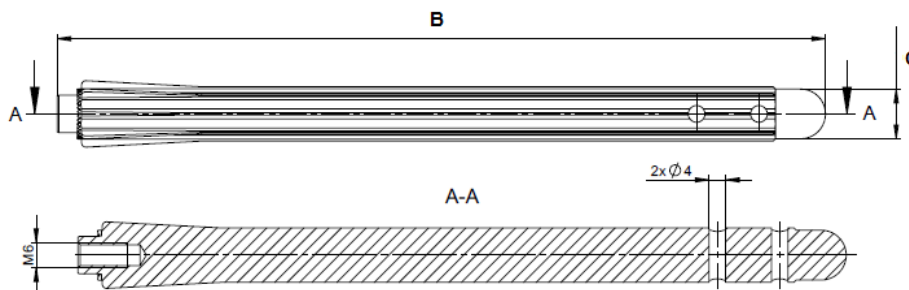

Fig. 58. AGILON® STEM CEMENTLESS 180 MM AND 240 MM

PRODUCT DESCRIPTION

AGILON® SHOULDER SYSTEM

SIZE	30 mm	60 mm	120 mm	180 mm	240 mm
LENGTH B [MM]	34,8	64,8	124,8	184,8	244,8

TABLE 18: LENGTH AGILON® STEM CEMENTLESS

SIZE	Ø 9	Ø 10	Ø 11	Ø 12	Ø 13	Ø 14	Ø 15	Ø 16	Ø 17	Ø 18
DIAMETER C [MM]	8,9	9,9	10,9	11,9	12,9	13,9	14,9	15,9	16,9	17,9

TABLE 19: DIAMETER AGILON® STEM CEMENTLESS

AGILON® Stem Cemented (REF 384XXXXX)

The AGILON® stem cemented is available in 12 sizes ranging from 60 to 120 mm in length (60 mm, 90 mm, and 120 mm) and in 3 diameters (60 mm, 90 mm, and 120 mm).

LENGTH [MM]	DIAMETER [MM]			
	6	8	10	12
60	x	x	x	x
90	x	x	x	x
120	x	x	x	x

TABLE 20: SIZES AGILON® STEM CEMENTLESS

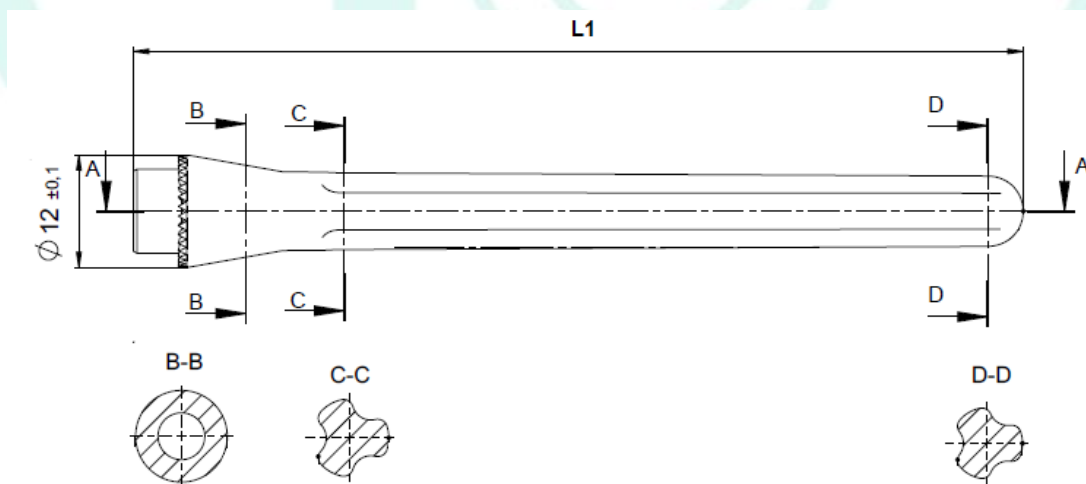

PRODUCT DESCRIPTION

AGILON® SHOULDER SYSTEM

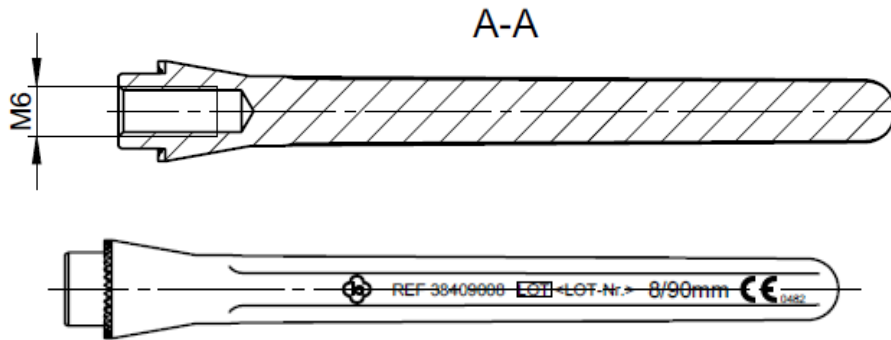

Fig. 59. AGILON® STEM CEMENTED DIMENSIONS

SIZE	LENGTH [MM]
	L1
6 x 60 mm	64,8
8 x 60 mm	64,8
10 x 60 mm	64,8
12 x 60 mm	64,8
6 x 90 mm	94,8
8 x 90 mm	94,8
10 x 90 mm	94,8
12 x 90 mm	94,8
6 x 120 mm	124,8
8 x 120 mm	124,8
10 x 120 mm	124,8
12 x 120 mm	124,8

TABLE 21: AGILON® STEM CEMENTED DIMENSIONS

13.4 Humeral Components without Extended Fit

AGILON® Screw (REF 382000XX)

The AGILON® screw is available in 4 sizes ranging from 25 to 40 mm in length (25 mm, 30 mm, 35 mm, and 40 mm).

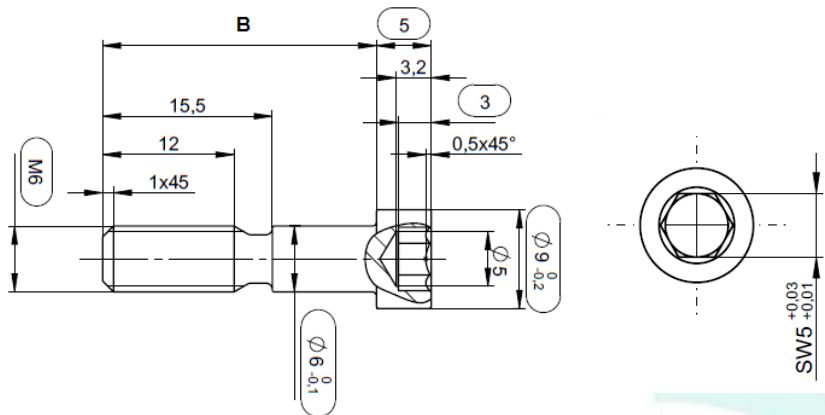

Fig. 60. AGILON® SCREW DIMENSIONS

SIZE	M6 x 25	M6 x 30	M6 x 35	M6 x 40
THREAD	M6	M6	M6	M6
SCREW LENGTH B [MM]	25	30	35	40
THREAD LENGTH [MM]	12	12	12	12

TABLE 22: SIZES AND DIMENSIONS AGILON® SCREW

AGILON® Extension Piece (REF 38200XXX)

The AGILON® extension piece is available in 3 sizes ranging from 5 to 10 mm in length (5 mm, 7.5 mm and 10 mm).

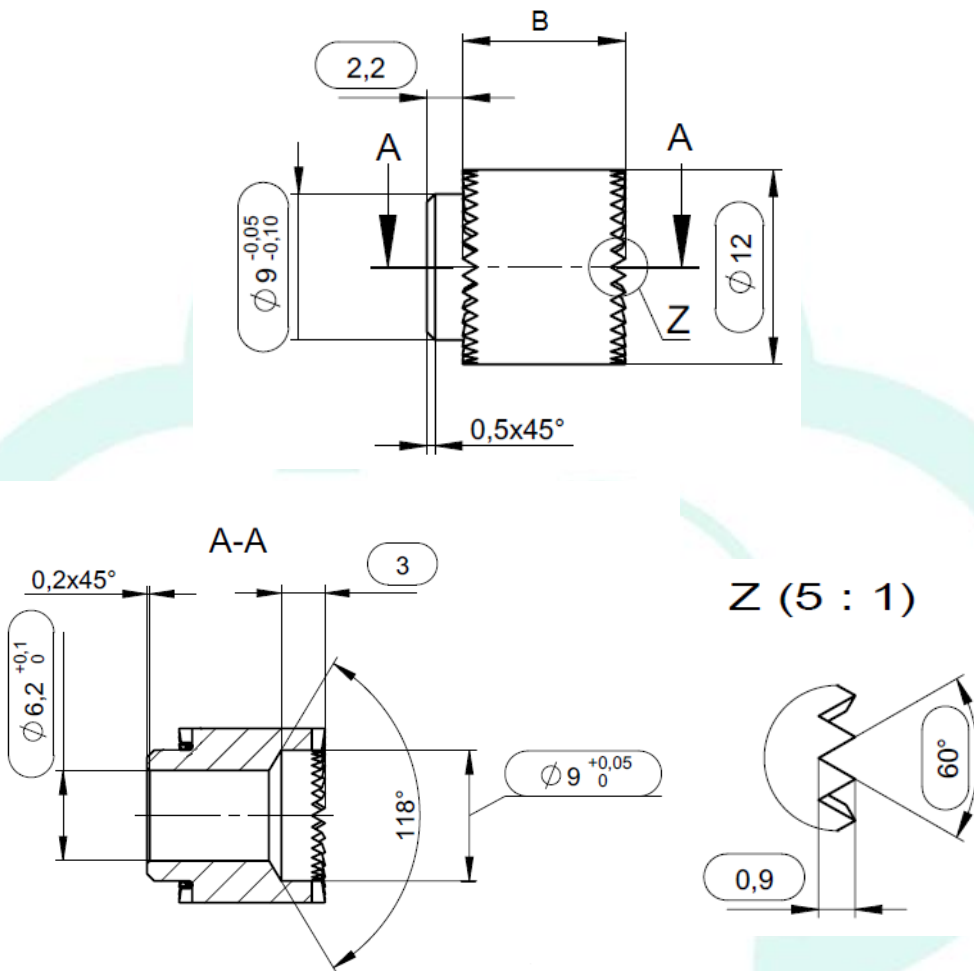

Fig. 61. AGILON® EXTENSION PIECE DIMENSIONS

SIZE	5	7.5	10
LENGTH B (WITHOUT FITTING) [MM]	5	7.5	10
LENGTH OF THE OUTER FITTING [MM]	2.2	2.2	2.2
LENGTH OF THE INNER FITTING [MM]	3	3	3

TABLE 23: SIZES AND DIMENSIONS AGILON® EXTENSION PIECE

AGILON® Metaphyseal Component Trauma (REF 38200001)

The AGILON® metaphyseal component trauma is available in one size with an inclination angle of 135°.

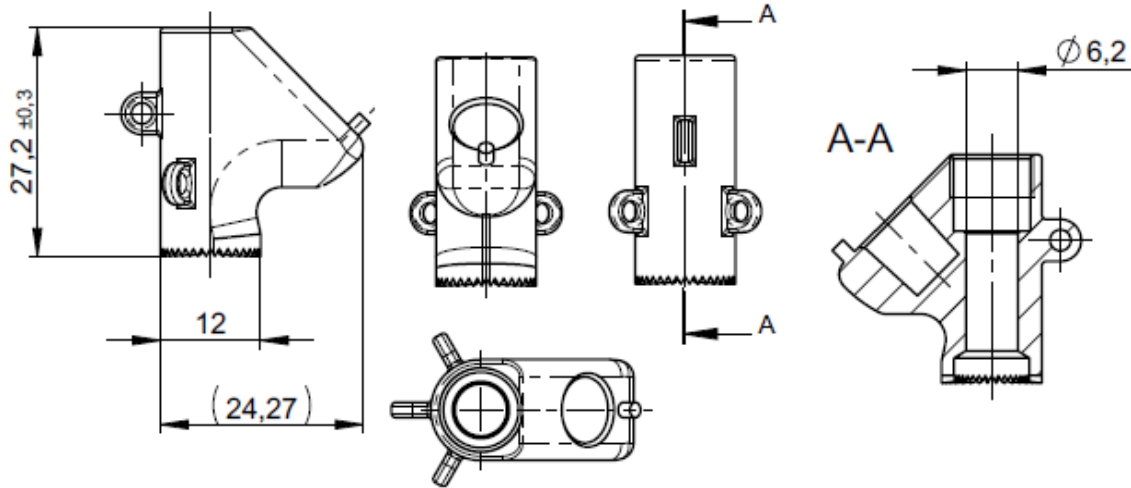

Fig. 62. AGILON® METAPHYSEAL COMPONENT TRAUMA (135°) DIMENSIONS

AGILON® Metaphyseal Component Primary (3820000X)

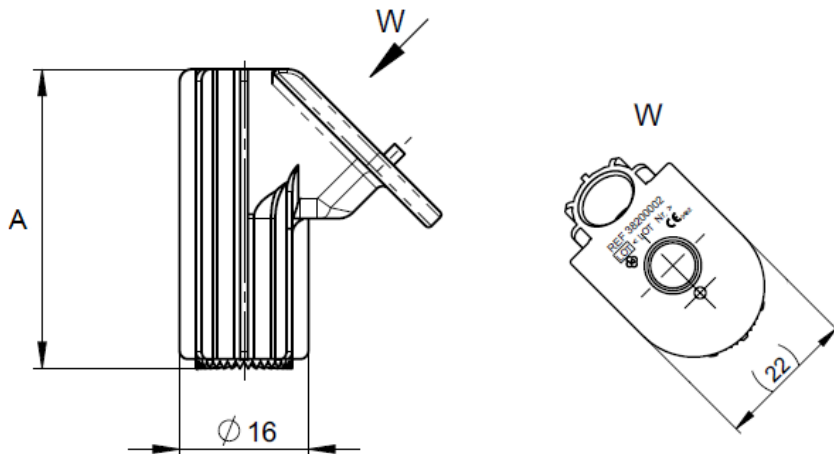

Fig. 63: AGILON® METAPHYSEAL COMPONENT PRIMARY DIMENSIONS

PRODUCT DESCRIPTION

AGILON® SHOULDER SYSTEM

METAPHYSEAL COMPONENT OMARTHROSIS	Inclination angle	Length A [mm]
135° 30 MM	135°	27,2
135° 40 MM	135°	37,2

TABLE 24: SIZES AND DIMENSIONS AGILON® METAPHYSEAL COMPONENT PRIMARY

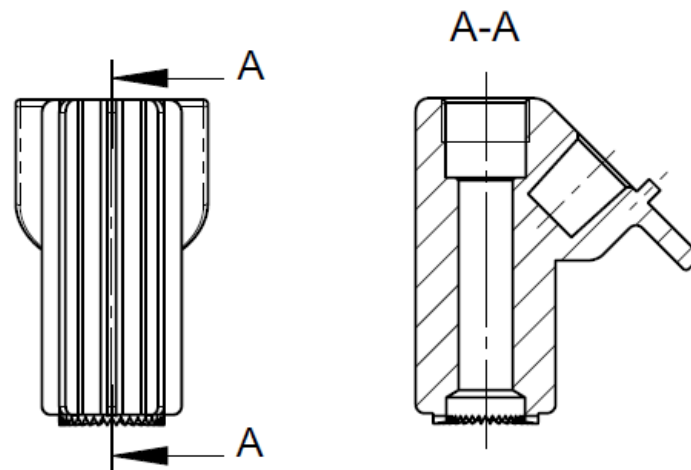

Fig. 64. AGILON® METAPHYSEAL COMPONENT PRIMARY DIMENSIONS

AGILON® Stem Cementless (REF 383XXXXX)

The AGILON® stem cementless is available in 32 sizes ranging from 60 to 240 mm in length (60 mm, 120 mm, 180 mm, and 240 mm) and in up to 9 different diameters. AGILON® stems cementless 180 and 240 mm in length are provided for complex fractures or revision arthroplasties.

LENGTH [MM]	DIAMETER [MM]									
	9	10	11	12	13	14	15	16	17	18
60		x	x	x	x	x	x	x	X	x
120		x	x	x	x	x	x	X		
180	x	x	x	x	x	x	x	X		
240	x	x	x	x	x	x	x	x		

TABLE 25: SIZES AGILON® STEM CEMENTLESS

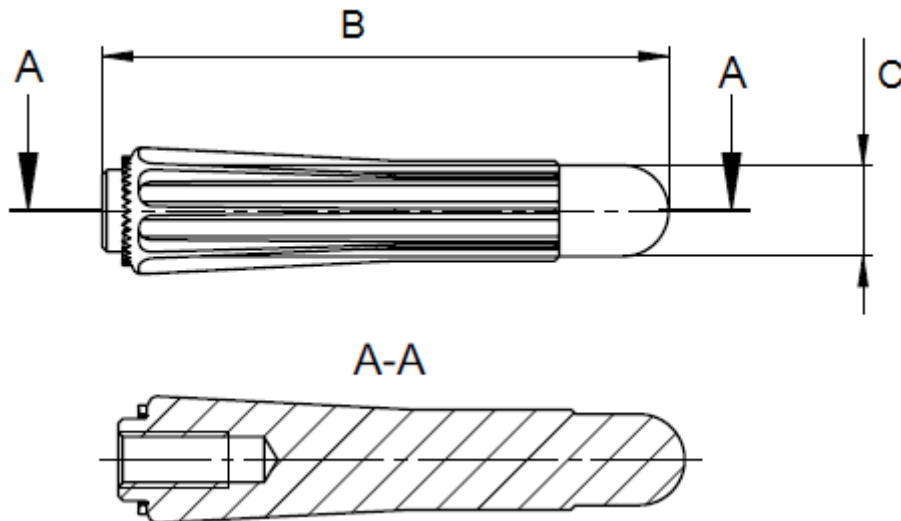

Fig. 65. AGILON® STEM CEMENTLESS 30 MM TO 120 MM

PRODUCT DESCRIPTION

AGILON® SHOULDER SYSTEM

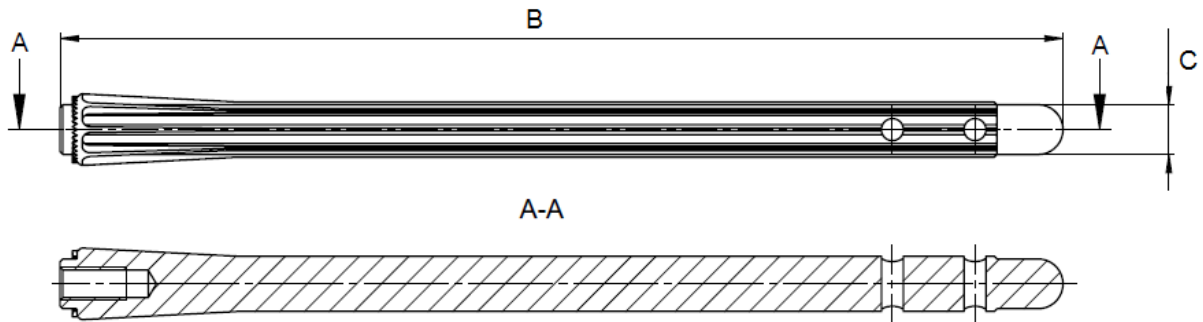

Fig. 66. AGILON® STEM CEMENTLESS 180 MM AND 240 MM

SIZE	60 mm	120 mm	180 mm	240 mm
LENGTH B [MM]	62.2	122.2	182.2	242.2

TABLE 26: LENGTH AGILON® STEM CEMENTLESS

SIZE	Ø 9	Ø 10	Ø 11	Ø 12	Ø 13	Ø 14	Ø 15	Ø 16	Ø 17	Ø 18
DIAMETER C [MM]	9	10	11	12	13	14	15	16	17	18

TABLE 27: DIAMETER AGILON® STEM CEMENTLESS

AGILON® Stem Cemented (REF 382XXXXX)

The AGILON® stem cemented is available in 8 sizes ranging from 90 to 120 mm in length (90 mm, and 120 mm) and in 4 diameters (6 mm, 8 mm, 10 mm and 12 mm) (TABLE 28).

LENGTH [MM]	DIAMETER [MM]			
	6	8	10	12
90	x	x	x	x
120	x	x </tr		

TABLE 28: SIZES AGILON® STEM CEMENTLESS

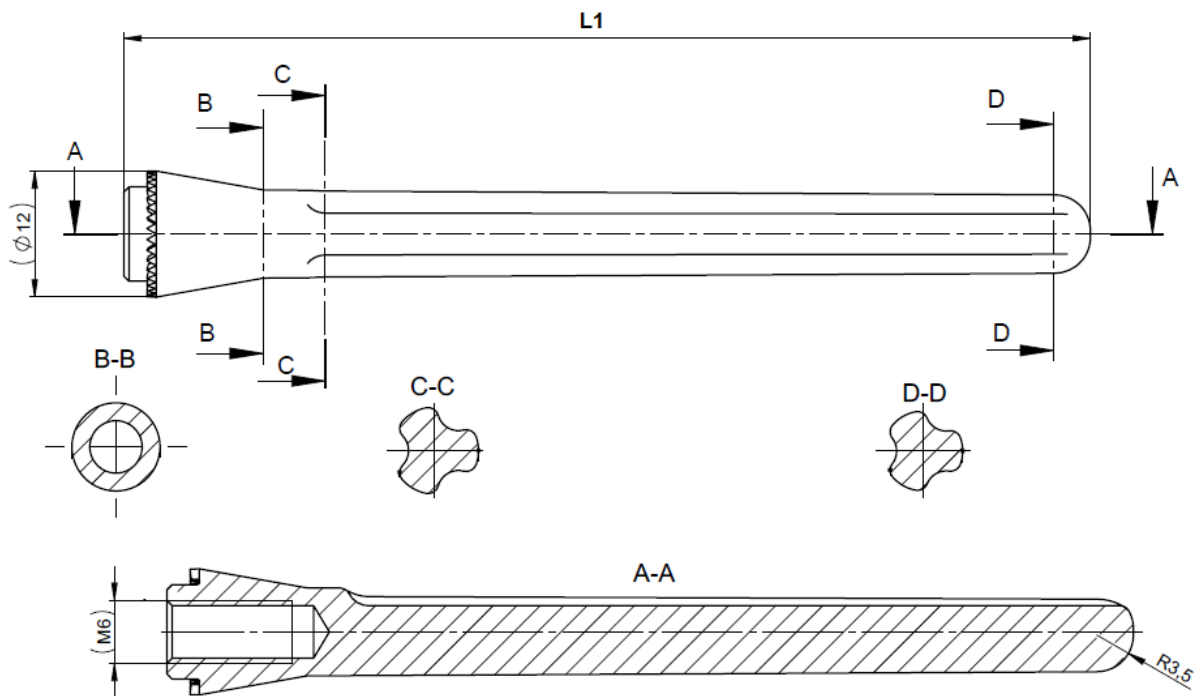

Fig. 67. AGILON® STEM CEMENTED DIMENSIONS

SIZE	LENGTH [MM]
	L1
6 x 90 mm	92.2
8 x 90 mm	92.2
10 x 90 mm	92.2
12 x 90 mm	92.2
6 x 120 mm	122.2
8 x 120 mm	122.2
10 x 120 mm	122.2
12 x 120 mm	122.2

TABLE 29: AGILON® STEM CEMENTED DIMENSIONS

Safety Screw

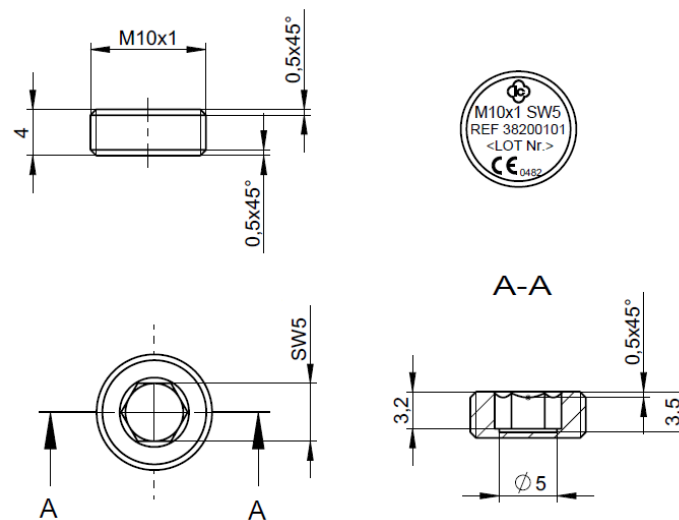

Fig. 68.SAFETY SCREW DIMENSIONS

13.5 Metaphyseal Implant

AGILON® MI

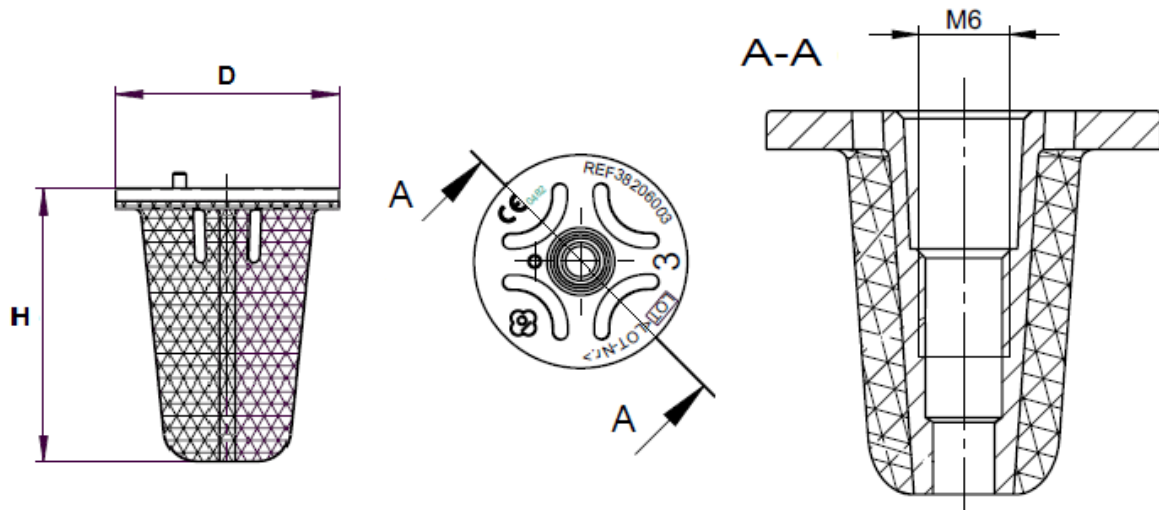

Fig. 69. AGILON® MI DIMENSIONS

SIZE	Diameter D [mm]	Height H [mm]
1	Ø 25.73	25
2	Ø 26.78	30
3	Ø 27.83	35
4	Ø 28.88	40
5	Ø 29.93	45

TABLE 30: SIZES AND DIMENSIONS AGILON® MI

14. Compatibility

The detailed component compatibility is given in the tables of combination. The summary can be found in the attachment of the instructions for use.

- ⇒ See Doc. *“Kombinationstabelle AGILON®”* in the folder *“11 Kombinationstabellen”*
- ⇒ See Doc. *“ 09300042 Schulterendoprothesen_Anhang I”* in the folder *“05Kennzeichnung\Gebrauchsinformation”*

15. Warnings

Information about warnings of the AGILON® System can be found in the Instruction for Use.

- ⇒ See Doc. Instruction for Use *“09300031 Schulterendoprothesen”* in the folder *“05 Kennzeichnung\Gebrauchsinformation”*

16. Product List (Identification of the Products)

For identification of the products by their respective number, please refer to the product list.

- ⇒ See Doc. *“Fbl_732-1-0-14_Produktliste AGILON (Productlist AGILON System) in the folder “02 Produktliste”*

17. Reference to Previous Generations and Similar Devices

Information about previous generations of the products can be found in the product history.

- ⇒ See Doc. *“Fbl_423-1-2-2_Produkthistorie Technische Dokumentation” (Product history Technical Documentation) in the folder “16 Produkthistorie”*

Similar devices available on the markets is the Shoulder Modular Replacement (SMR) Anatomic from Lima Corporate, the SMR Reverse HP from Lima Corporate and the Simpliciti™ Shoulder System from Tornier/Wright Medical

LIST OF FIGURES

Fig. 1. AGILON SHOULDER SYSTEM OVERVIEW	5
Fig. 2. COMPONENTS OF THE AGILON® SHOULDER SYSTEM	7
Fig. 3. AGILON® CAP	10
Fig. 4. AGILON® CAP INNER SURFACE	10
Fig. 5. AGILON® CAP - ECCENTRICITY	10
Fig. 6. AGILON® CTA CAP	11
Fig. 7. AGILON® CAP INVERSE	12
Fig. 8. AGILON® RETENTIVE CAP INVERSE	12
Fig. 9. AGILON® GLENOID CEMENTLESS ROUND	13
Fig. 10. AGILON® GLENOID CEMENTLESS ANATOMICAL (METAL BACK)	13
Fig. 11. AGILON® GLENOID PE-INSERT	14
Fig. 12. AGILON® PE-GLENOSPHERE	14
Fig. 13. AGILON® PE-GLENOSPHERE - ECCENTRICITY PREVENTS SCAPULA NOTCHING	15
Fig. 14. AGILON® SCREW	15
Fig. 15. AGILON® EXTENSION PIECE	15
Fig. 16. AGILON® METAPHYSEAL COMPONENT TRAUMA (135° LEFT, 155° RIGHT)	16
Fig. 17. REBUILD THE PROXIMAL HUMERUS WITH AGILON® METAPHYSEAL COMPONENT TRAUMA	16
Fig. 18. AGILON® METAPHYSEAL COMPONENT OMARTHROSIS	17
Fig. 19. AGILON® STEM CEMENTLESS	18
Fig. 20. AGILON® STEM CEMENTED	18
Fig. 21. AGILON® SCREW	19
Fig. 22. AGILON® EXTENSION PIECES	19
Fig. 23. AGILON® METAPHYSEAL COMPONENT TRAUMA	19
Fig. 24. REBUILD THE PROXIMAL HUMERUS WITH AGILON® METAPHYSEAL COMPONENT TRAUMA	20
Fig. 25. AGILON® METAPHYSEAL COMPONENT PRIMARY	20
Fig. 26. AGILON® STEM CEMENTLESS	21
Fig. 27. AGILON® STEM CEMENTED	21
Fig. 28. SAFETY SCREW	21
Fig. 29. AGILON® MI	22
Fig. 30. AGILON® MI – PROXIMAL VIEW (LEFT), DISTAL VIEW (CENTRE) AND SIDE VIEW (RIGHT)	22
Fig. 31. AGILON® CAPS	24
Fig. 32. AGILON® GLENOID CEMENTLESS ROUND	25
Fig. 33. AGILON® GLENOID CEMENTLESS ANATOMICAL (METAL BACK)	25
Fig. 34. AGILON® SCREW	25
Fig. 35. AGILON® STEM CEMENTED	26
Fig. 36. SAFETY SCREW	27
Fig. 37. AGILON® CAP DIMENSIONS	28
Fig. 38. AGILON® CTA CAP DIMENSIONS	29
Fig. 39. AGILON® CAP INVERSE DIMENSIONS	30
Fig. 40. AGILON® CAP INVERSE WITH DIFFERENT NECK LENGTHS (S, M, L)	31
Fig. 41. AGILON® RETENTIVE CAP INVERSE DIMENSIONS	31
Fig. 42. AGILON® GLENOID CEMENTLESS ROUND SIZE 1	32
Fig. 43. AGILON® GLENOID CEMENTLESS ANATOMICAL DIMENSIONS	33
Fig. 44. AGILON® GLENOID CEMENTLESS ANATOMICAL DIMENSIONS (SIZE 2 AND SIZE3)	33
Fig. 45. AGILON® GLENOID PE-INSERT DIMENSIONS	34
Fig. 46. AGILON® PE-GLENOSPHERE DIMENSIONS	35
Fig. 47. AGILON® PE-GLENOSPHERE DIMENSIONS – NEUTRAL (LEFT) AND ECCENTRICAL (RIGHT)	35
Fig. 48. AGILON® SCREW DIMENSIONS	36
Fig. 49. AGILON® SCREW DIMENSIONS (2)	36
Fig. 50. AGILON® EXTENSION PIECE DIMENSIONS	37
Fig. 51. AGILON® METAPHYSEAL COMPONENT TRAUMA (135°) DIMENSIONS	38
Fig. 52. AGILON® METAPHYSEAL COMPONENT TRAUMA (155°) DIMENSIONS	39

PRODUCT DESCRIPTION

AGILON® SHOULDER SYSTEM

Fig. 53. AGILON® METAPHYSEAL COMPONENT OMARTHROSIS (135°) DIMENSIONS	40
Fig. 54. AGILON® METAPHYSEAL COMPONENT OMARTHROSIS (155°) DIMENSIONS	40
Fig. 55. AGILON® METAPHYSEAL COMPONENT OMARTHROSIS (135°) DIMENSIONS	41
Fig. 56. AGILON® METAPHYSEAL COMPONENT OMARTHROSIS (155°) DIMENSIONS	41
Fig. 57. AGILON® STEM CEMENTLESS 30 MM TO 120 MM.....	42
Fig. 58. AGILON® STEM CEMENTLESS 180 MM AND 240 MM	42
Fig. 59. AGILON® STEM CEMENTED DIMENTSIONS	44
Fig. 60. AGILON® SCREW DIMENSIONS	45
Fig. 61. AGILON® EXTENSION PIECE DIMENSIONS.....	46
Fig. 62. AGILON® METAPHYSEAL COMPONENT TRAUMA (135°) DIMENSIONS.....	47
Fig. 63: AGILON® METAPHYSEAL COMPONENT PRIMARY DIMENSIONS.....	47
Fig. 64. AGILON® METAPHYSEAL COMPONENT PRIMARY DIMENSIONS.....	48
Fig. 65. AGILON® STEM CEMENTLESS 30 MM TO 120 MM.....	49
Fig. 66. AGILON® STEM CEMENTLESS 180 MM AND 240 MM	50
Fig. 67. AGILON® STEM CEMENTED DIMENTSIONS	51
Fig. 68.SAFETY SCREW DIMENSIONS	52
Fig. 69. AGILON® MI DIMENSIONS	53



LIST OF TABLES

TABLE 1: MEDIOLATERAL OFFSET DUE TO CAP ECCENTRICITY (17MM CAP)	11
TABLE 2 AGILON® CAPS- COATING SPECIFICATIONS FOR TiN.....	24
TABLE 3: GLENOID CEMENTLESS ROUND / ANATOMICAL- COATING SPECIFICATION FOR HA	25
TABLE 4: COATING SPECIFICATION FOR TIN	26
TABLE 5 EPORE® SPECIFICATION	27
TABLE 6: SIZES AND DIMENSIONS AGILON® CAP	28
TABLE 7: SIZES AND DIMENSIONS AGILON® CTA CAP	29
TABLE 8: SIZES AND DIMENSIONS AGILON® CAP INVERSE	30
TABLE 9: SIZES AND DIMENSIONS AGILON® RETENTIVE CAP INVERSE	32
TABLE 10: SIZES AND DIMENSIONS AGILON® GLENOID CEMENTLESS ROUND.....	32
TABLE 11: SIZES AND DIMENSIONS AGILON® GLENOID CEMENTLESS ANATOMICAL	33
TABLE 12: SIZES AND DIMENSIONS AGILON® GLENOID PE-INSERT	34
TABLE 13: SIZES AND DIMENSIONS AGILON® PE-GLENOSPHERE	35
TABLE 14: SIZES AND DIMENSIONS AGILON® SCREW	36
TABLE 15: SIZES AND DIMENSIONS AGILON® EXTENSION PIECE	37
TABLE 16: SIZES AND DIMENSIONS AGILON® METAPHYSEAL COMPONENT OMARTHROSIS	40
TABLE 17: SIZES AGILON® STEM CEMENTLESS.....	42
TABLE 18: LENGTH AGILON® STEM CEMENTLESS.....	43
TABLE 19: DIAMETER AGILON® STEM CEMENTLESS.....	43
TABLE 20: SIZES AGILON® STEM CEMENTLESS.....	43
TABLE 21: AGILON® STEM CEMENTED DIMENSIONS.....	44
TABLE 22: SIZES AND DIMENSIONS AGILON® SCREW	45
TABLE 23: SIZES AND DIMENSIONS AGILON® EXTENSION PIECE	46
TABLE 24: SIZES AND DIMENSIONS AGILON® METAPHYSEAL COMPONENT PRIMARY	48
TABLE 25: SIZES AGILON® STEM CEMENTLESS.....	49
TABLE 26: LENGTH AGILON® STEM CEMENTLESS.....	50
TABLE 27: DIAMETER AGILON® STEM CEMENTLESS.....	50
TABLE 28: SIZES AGILON® STEM CEMENTLESS.....	51
TABLE 29: AGILON® STEM CEMENTED DIMENSIONS.....	52
TABLE 30: SIZES AND DIMENSIONS AGILON® MI.....	53
TABLE 31: LIST OF ABBREVIATIONS	58

LIST OF ABBREVIATIONS

ABBREVIATION	ABBREVIATED TERM
TiN	Titanium nitride
cpTi	Commercially Pure Titanium
PE	Polyethylene
UHMWPE	Ultra-high-molecular-weight polyethylene
CoCrMo	Cobalt Chrome Molybdenum
TiAl6V4	Titanium-aluminium-vanadium alloy
HA	Hydroxyapatite
CTA	Cuff tear arthropathy
MI	Metaphyseal implant
✓	Indicates "Combination is approved by implantcast GmbH"
◆	Indicates "Combination is not recommended by implantcast GmbH"
	Indicates "Combination is not approved by implantcast GmbH"

TABLE 31: LIST OF ABBREVIATIONS

DOCUMENT REVISION HISTORY

DATE	REVISION	CHANGES	AUTHOR	COMMENTS
13.06.2017	0	Creation	S. Deutsch	---
14.08.2020	1	ÄA 20-568	J. Müller	---
14.02.2022	2	ÄA 22-098	E. Kavak	---

