

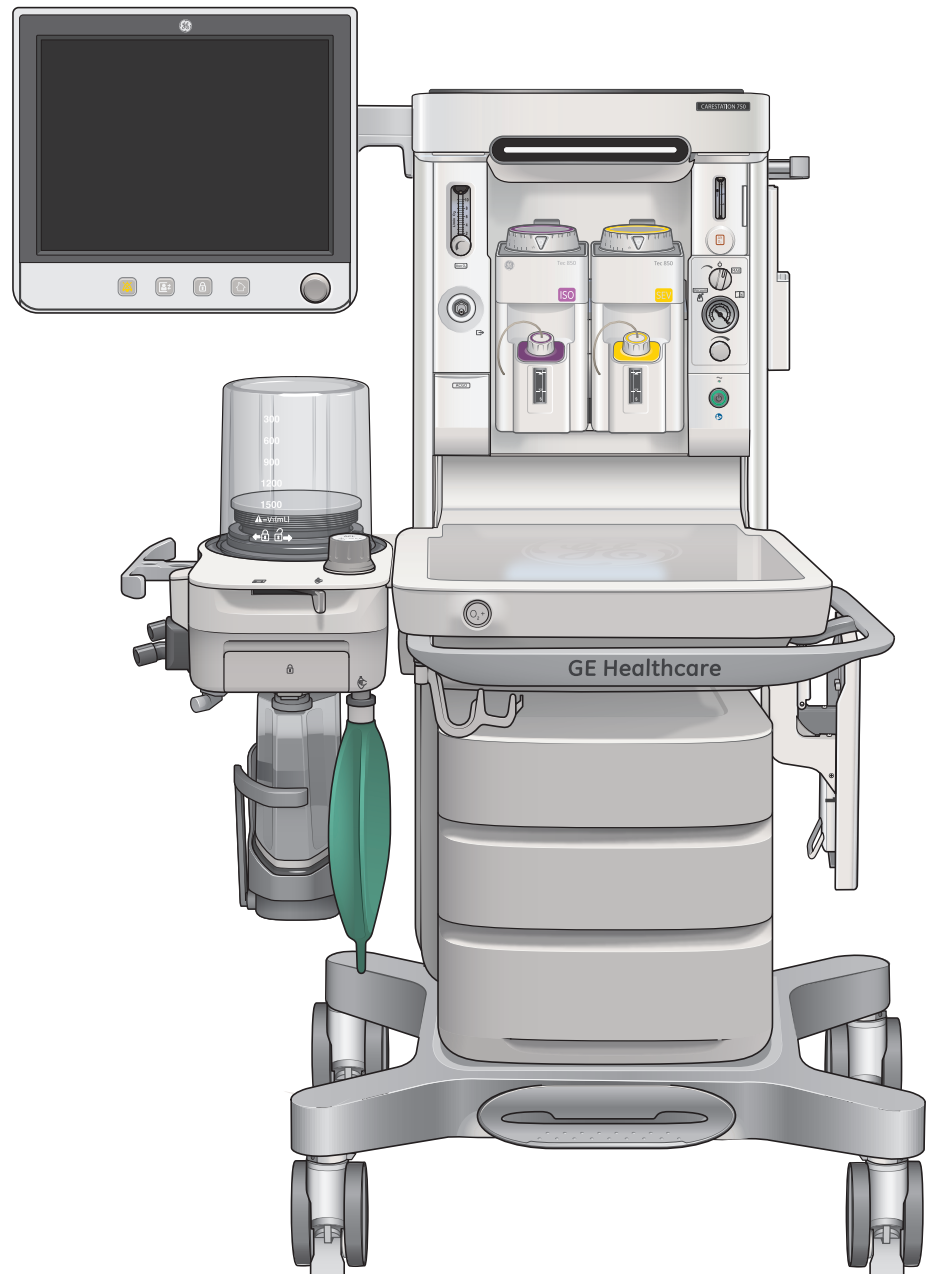

Carestation™ 750 Anesthesia Delivery System

**Clinical Reference Guide
Version 1.0**







Carestation™ 750 Anesthesia Delivery System

Clinical Reference Guide
Version 1.0

Notice

Configurations available for this product depend on local market and standards requirements. Illustrations in this course may not represent all configurations of the product. This guide does not cover the operation of every accessory. Screens displayed in this training are examples only and may vary from your system due to software, options, and database. Always refer to your application for exact screen representation.

The materials contained in this guide are intended for educational purposes only. This guide does not establish specifications, operating procedures, or maintenance methods for any of the products referenced. Always refer to the official written materials (labeling) provided with the product for specifications, operating procedures, and maintenance requirements.

The materials contained in this guide are intended for educational purposes only. These materials may include clinical concepts and definitions.

No diagnostic statements are inferred or included in these materials. All clinical diagnosis should be made by a trained physician or clinician. All patient names or other protected health information or data contained in any image within this material is fictitious. Any similarity to actual persons is coincidental.

Contents

01 System overview	1	Starting manual ventilation	25
Introduction	1	Starting mechanical ventilation	25
Front view components	2	Changing a ventilator mode and settings.....	26
Breathing system components.....	3	06 Alarms and Trends	27
Right side view components	4	Setting alarm limits	27
Rear view components.....	5	Additional alarm settings	28
Left side view components.....	6	Setting Auto Limits	29
Central and caster brakes.....	7	Viewing Trends.....	29
Using the bag support arm.....	8	07 Ventilation modes	30
02 Navigation	9	Volume control mode (VCV).....	30
Display Controls	9	Pressure control mode (PCV).....	30
Touch points.....	10	PCV-VG mode.....	31
Anesthesia system display	11	SIMV VCV mode.....	31
Using menus.....	12	SIMV PCV mode.....	32
Using the ComWheel.....	13	SIMV PCV-VG mode	33
Using quick keys	14	PSVPro™ Ventilation Mode	34
03 Operation overview	15	CPAP + PSV mode.....	34
Turning on the system	15	08 Special features	35
Changing gas settings.....	16	ecoFLOW overview	35
Using the O ₂ flush button	16	ecoFLOW menu components	36
Using the APL valve	17	Activating the ecoFLOW split screen	37
Using the Bag/Vent switch	17	Recruitment Maneuver.....	37
Using the vaporizer	18	Pause Gas Flow	38
Using the ACGO.....	18	Spirometry overview.....	39
Aux O ₂ +Air.....	19	Spirometry loop components	40
04 Checkout	20	Saving, viewing and deleting spirometry loops	40
Checkout overview.....	20	Spirometry setup	41
Checkout full test.....	21	Cardiac Bypass.....	42
05 Starting a case	22	09 End of Case and Standby	43
Start Case menu overview	22	End Case.....	43
Starting a case using default settings.....	23	Standby.....	44
Starting a case using custom settings	24	Turning off the system	45

01 System overview

Introduction

The Carestation 750/750c anesthesia systems combine advanced anesthesia delivery, patient monitoring, and care information management. Optional integrated features include auxiliary common gas outlet, auxiliary O₂ outlet, auxiliary O₂+Air outlet, suction control and respiratory gas monitoring.

Intended use

The Carestation 750/750c anesthesia systems are intended to provide monitored anesthesia care, general inhalation anesthesia and/or ventilatory support to a wide range of patients (neonatal, pediatric, and adult). The anesthesia systems are suitable for use in a patient environment, such as hospitals, surgical centers, or clinics.

The systems are intended to be operated by a clinician qualified in the administration of general anesthesia.

Note: *The Carestation 750 system is the standard trolley system, while the Carestation 750c system is the pendant system. This clinical reference guide will focus on the standard trolley system and use the term “Carestation 750” instead of “Carestation 750/750c”. The operation of both systems is identical.*

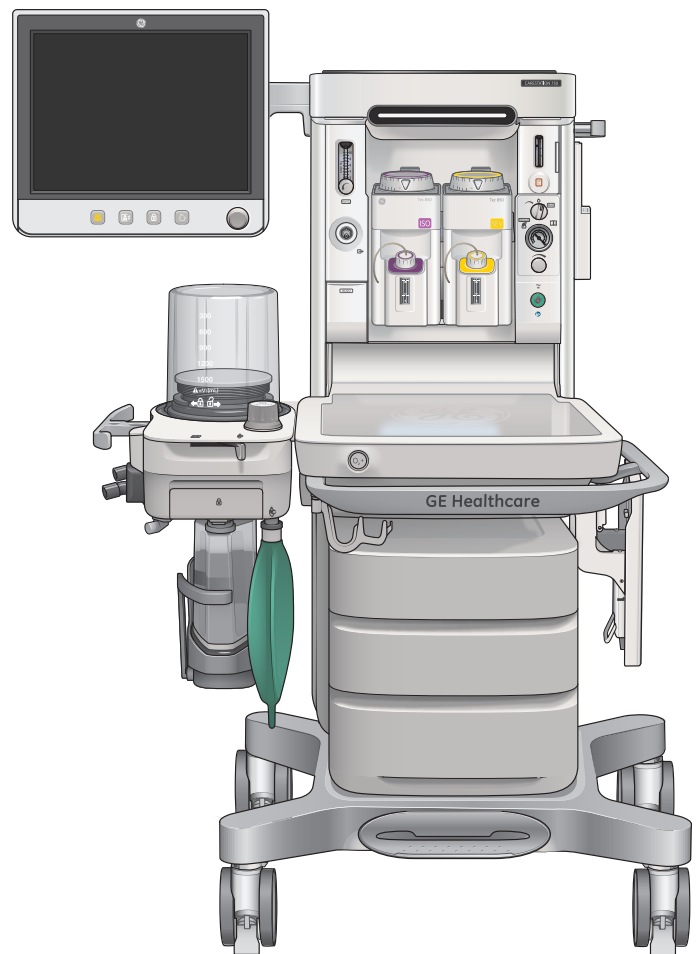

Front view components

- 1. Anesthesia display
- 2. Auxiliary O₂ flow control (optional)
- 3. Alt O₂ flow control
- 4. Suction regulator and control (optional)
- 5. On/Standby switch
- 6. Vaporizer
- 7. Flip-up shelf (optional)
- 8. Drawers
- 9. Central brake
- 10. Caster brakes and cable sweeper
- 11. O₂ flush
- 12. Auxiliary Common Gas Outlet (ACGO) or Auxiliary O₂+Air switch and port (optional)
- 13. Auxiliary O₂ outlet (optional)

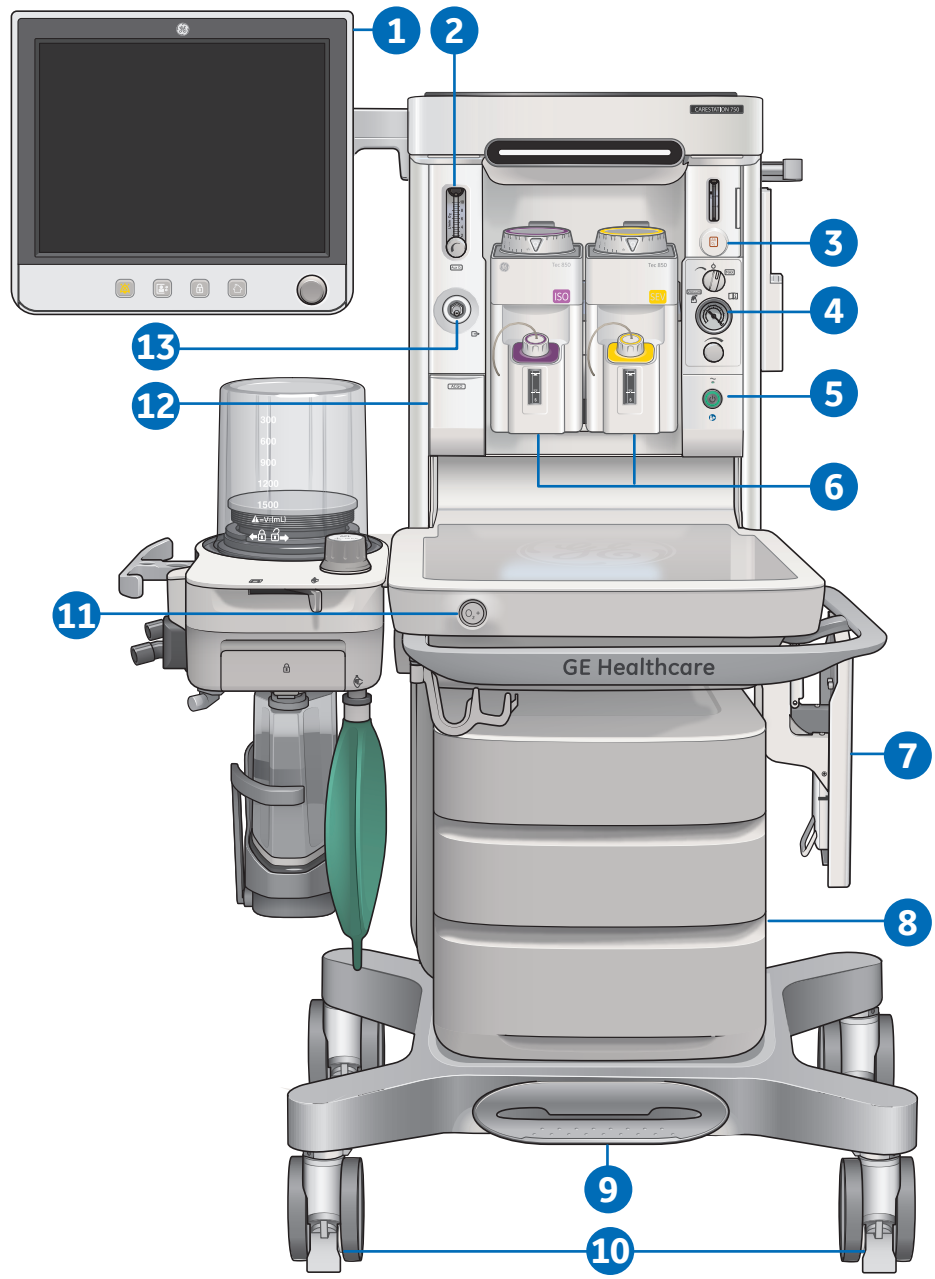

Breathing system components

1. Bellows assembly
2. Adjustable pressure-limiting (APL) valve
3. Bag/Vent switch
4. Bag hose connection
5. Absorber canister
6. Absorber canister lifter handle
7. Leak test plug
8. Inspiratory port
9. Expiratory port
10. Breathing system guard
11. Bag hose
12. Bag support arm (optional)
13. Breathing bag

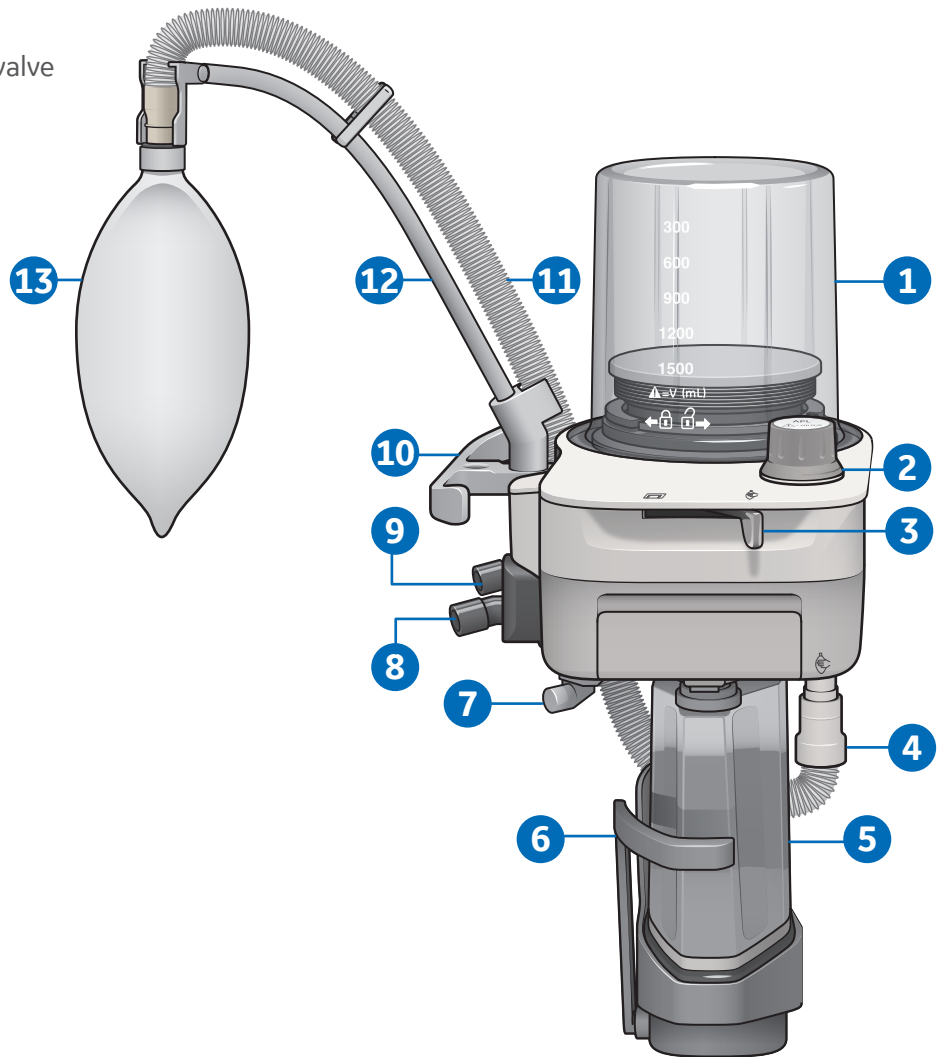

Right side view components

1. Side rail
2. Pipeline connections
3. Right dovetail
4. Mains inlet and Mains power fuses
5. Outlet circuit breakers (optional)

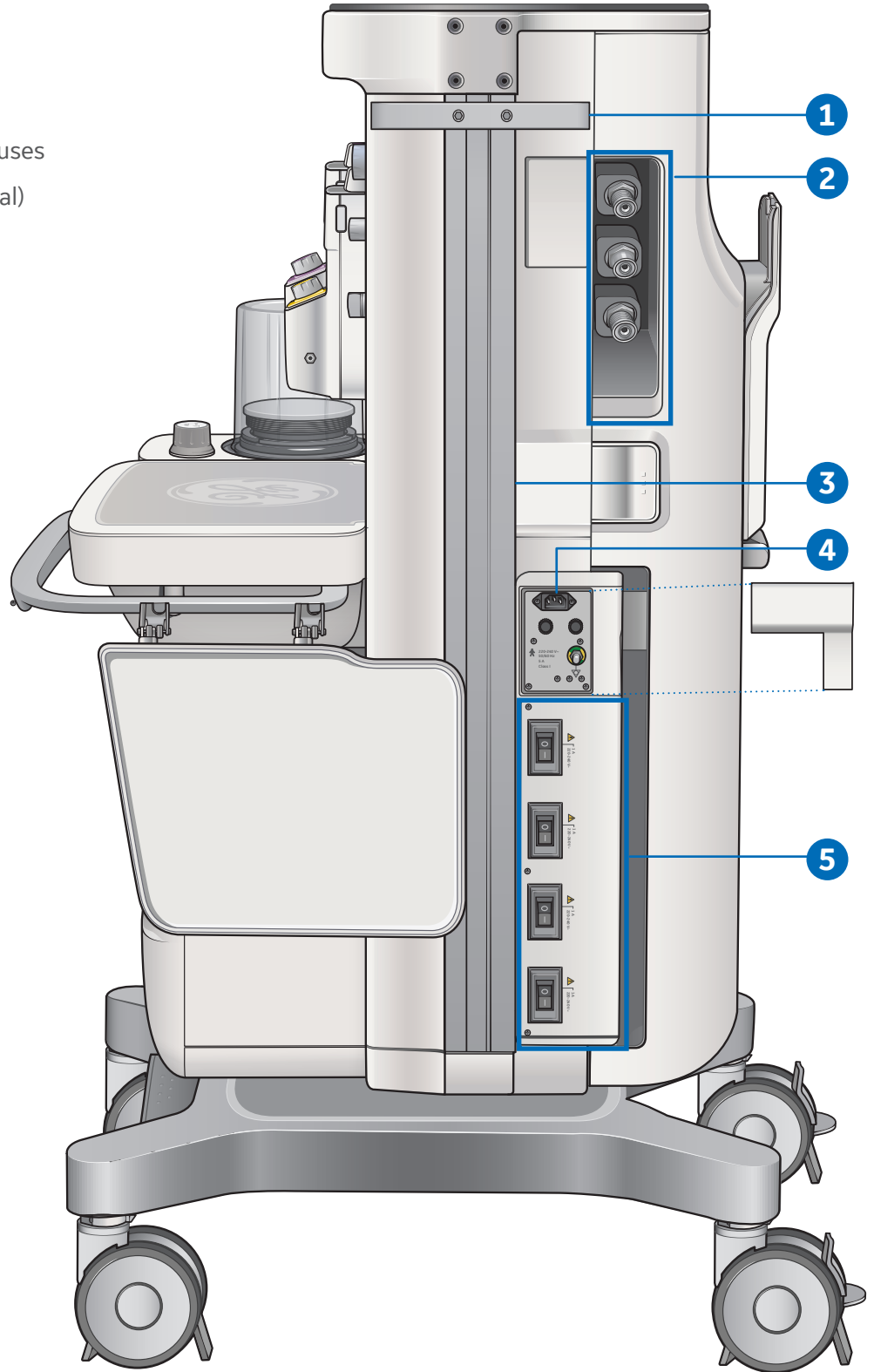

Rear view components

1. Display arm
2. Suction trap
3. Back cover (optional)

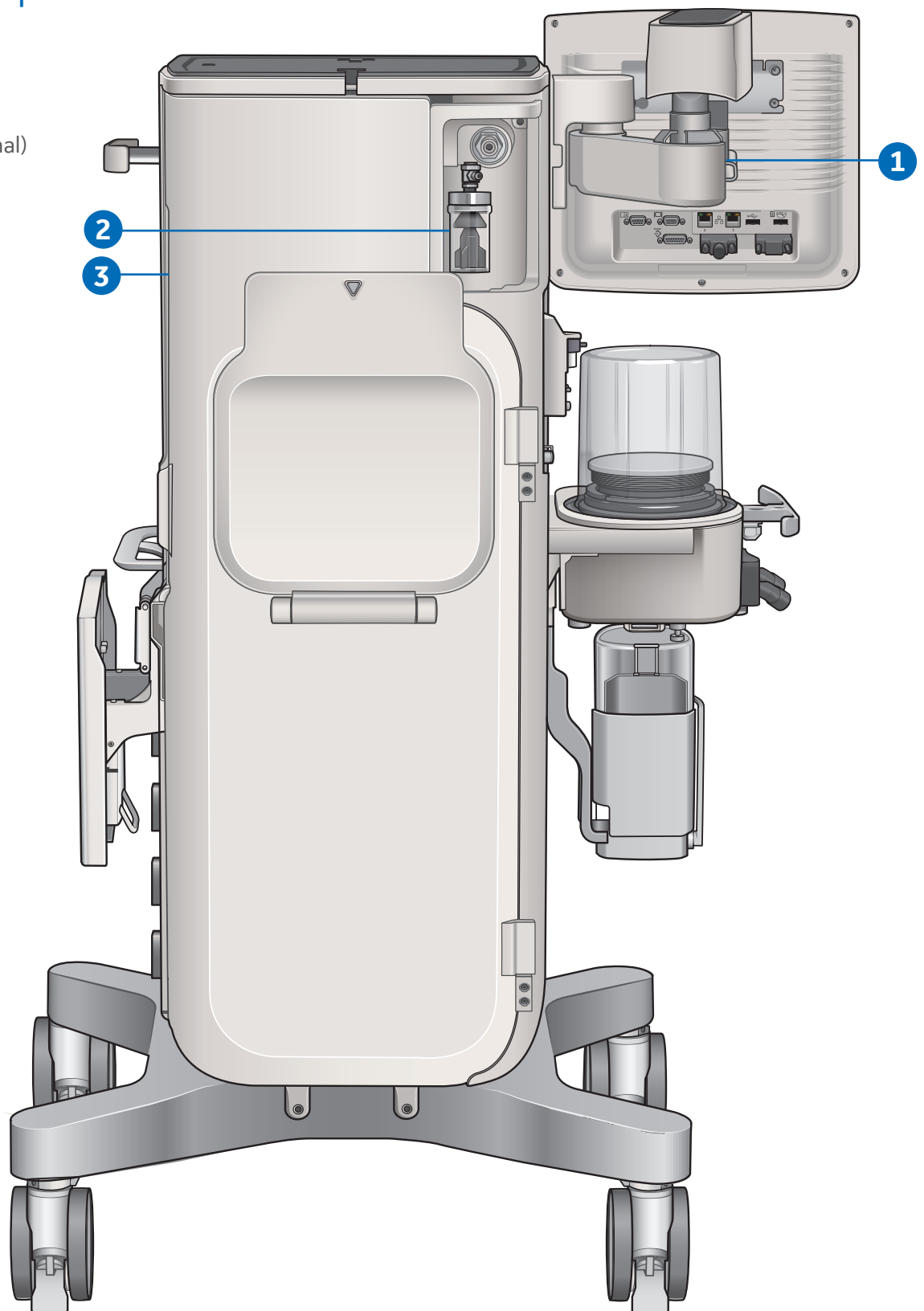

Left side view components

1. Airway module (optional) and sample gas return port
2. Left dovetail
3. Anesthesia Gas Scavenging System (AGSS) connection

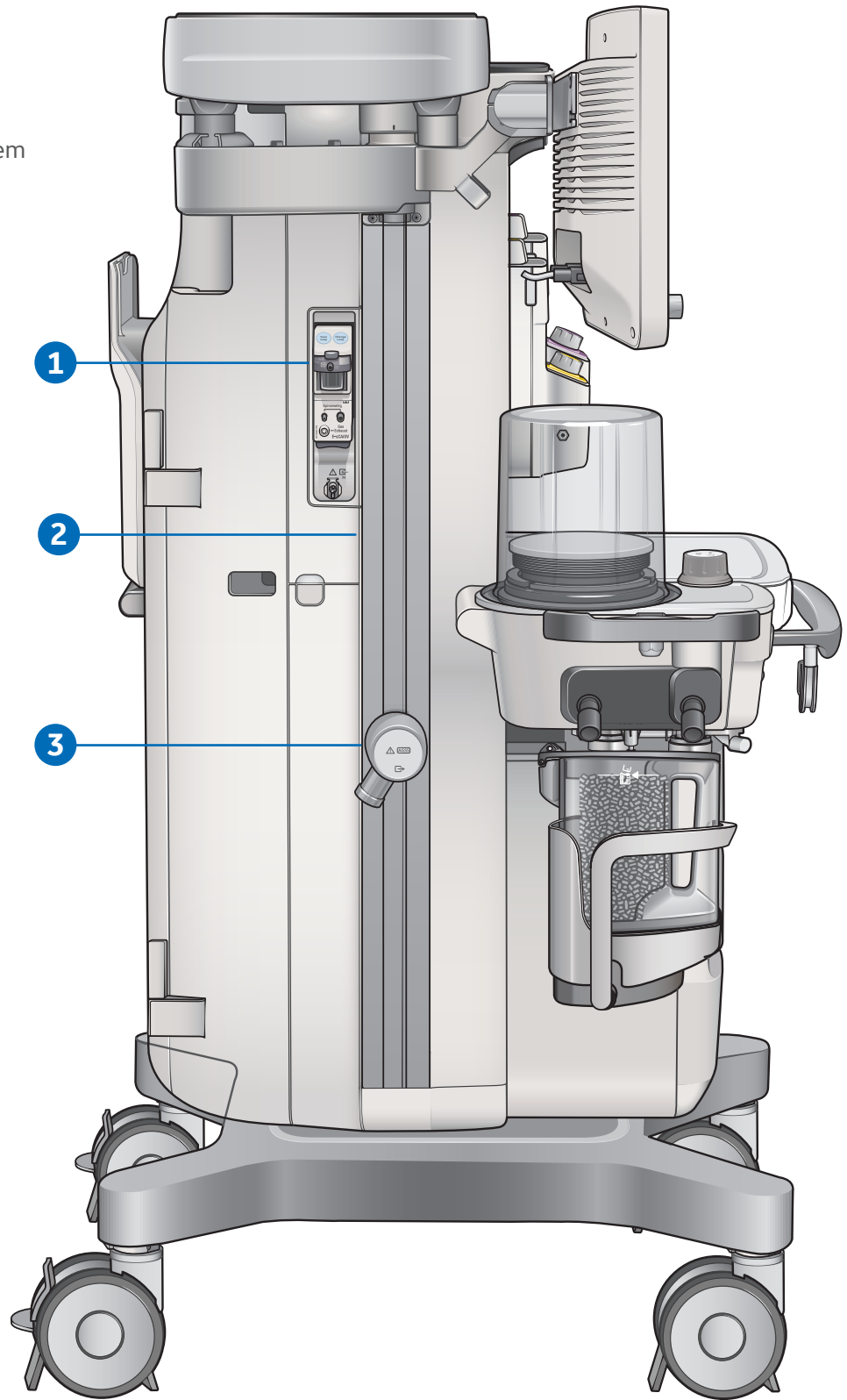

Central and caster brakes

The Carestation 750 system has one central brake with two brakes on the rear casters that hold the system in place.

- 1. Central brake:** Push down on the central brake to lock the system in place. Lift up on the central brake to release the brake.
- 2. Caster brakes:** Push down on the lower portion of the brake pedal to lock the system in place. Push down on the upper portion of the brake to release the brake.

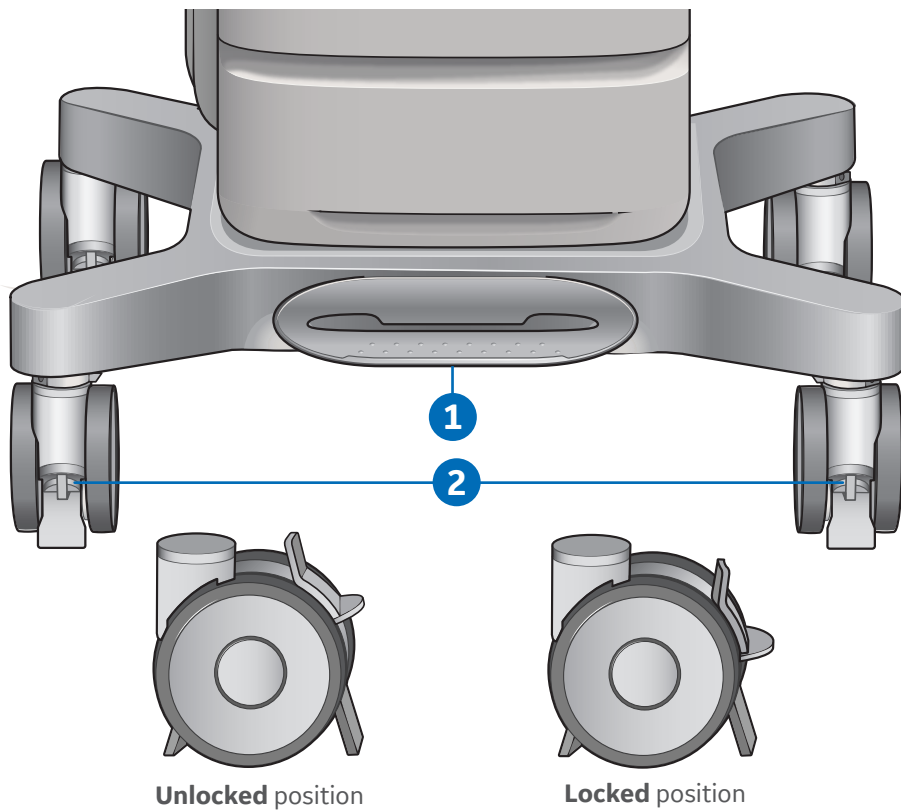

Using the bag support arm

Use the optional bag support arm to hold the breathing circuit bag.

The bag support arm can be moved up or down and left or right.

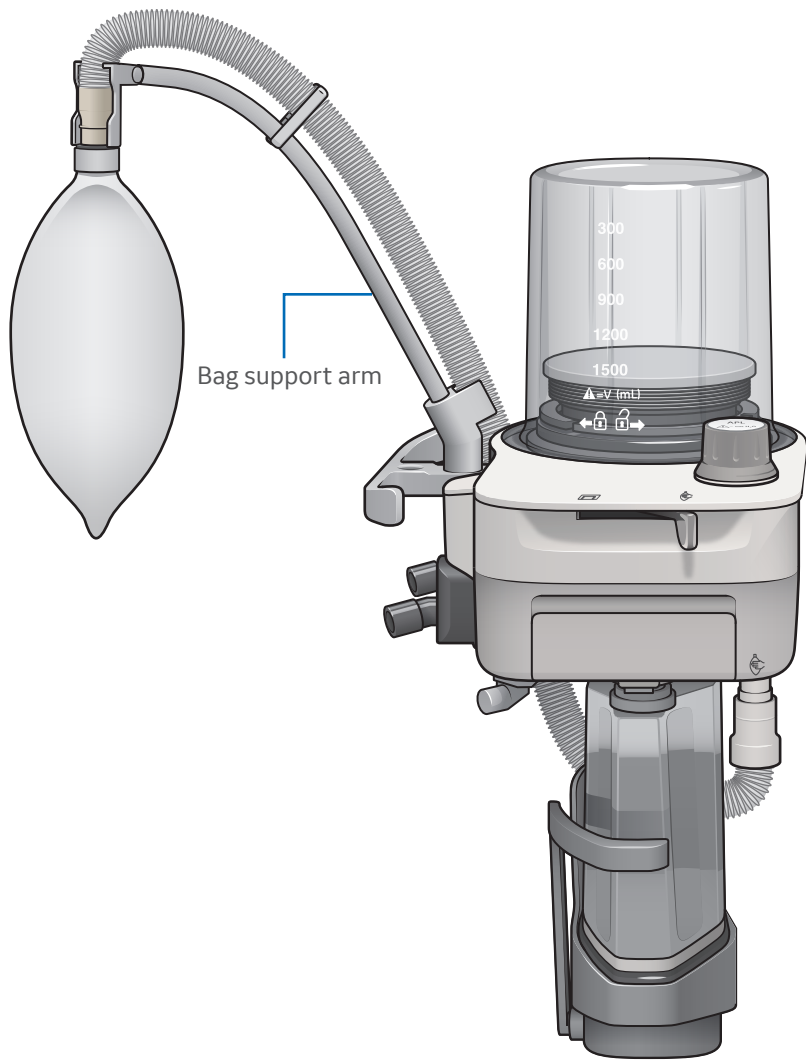

02 Navigation

Display Controls

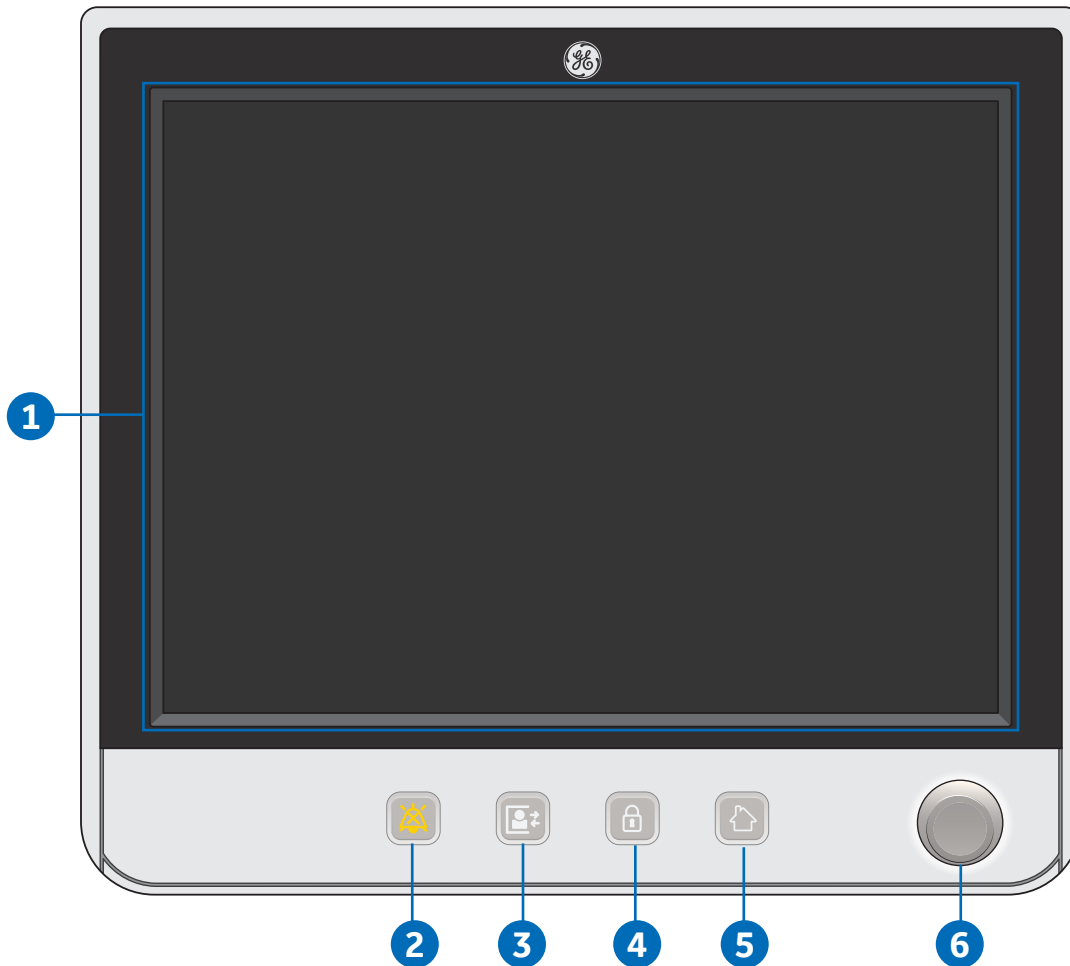

- 1. Touchscreen:** Activates functions when touch areas on the screen are selected.
- 2. Audio Pause key:** Stops audio for 120 seconds for any active, eligible high and medium priority alarms. Prevents audio (audio off) for 90 seconds when no medium or high priority alarms are active.
- 3. Start/End Case key:** Initiates Start or End Case function.
- 4. Screen Lock/Unlock key:** Locks the touchscreen. Toggles between lock and unlock functions.
- 5. Home key:** Removes all menus from the screen.
- 6. ComWheel:** Selects a menu item or confirms a setting. Turn clockwise or counterclockwise to scroll through menu items or change settings.

Touch points

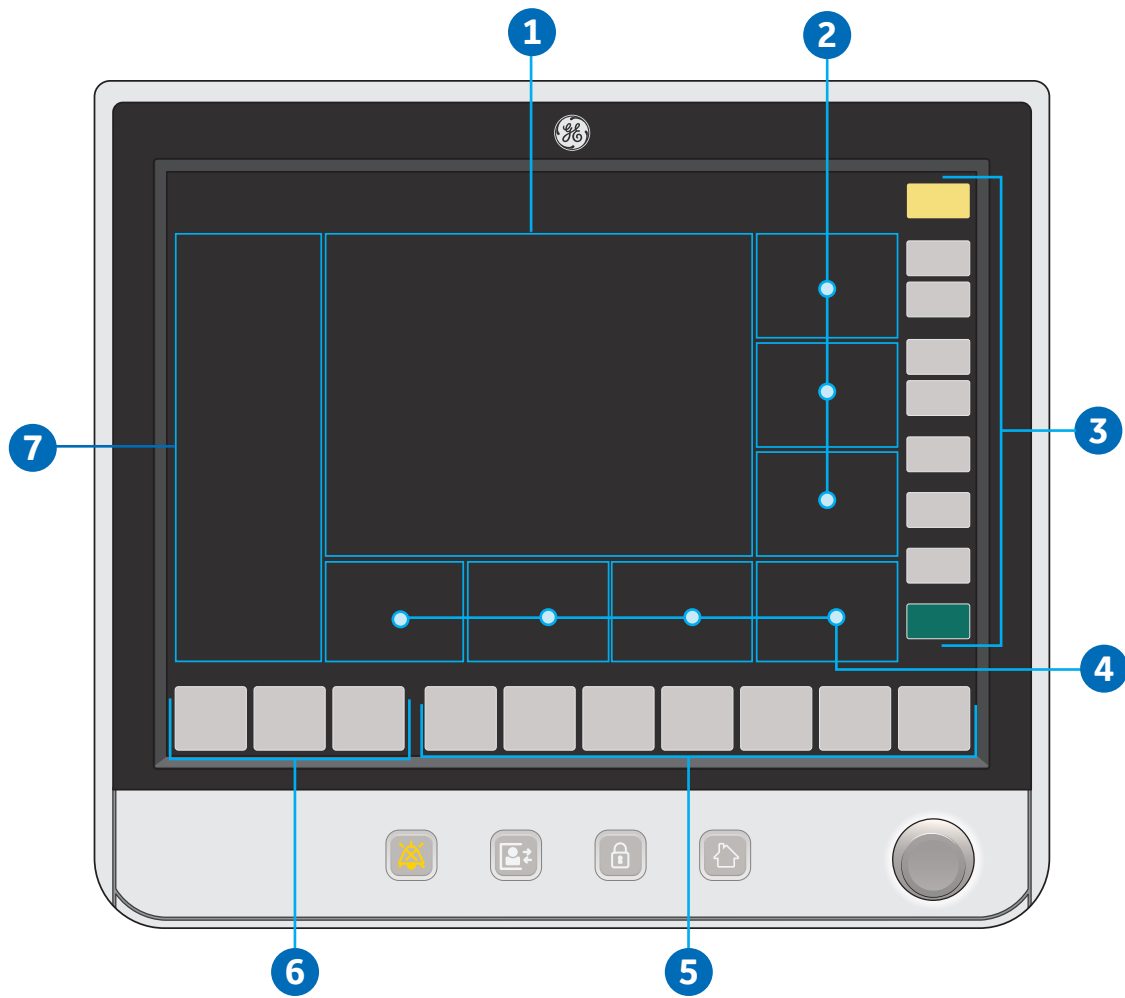

1. Wave fields
2. Measured values
3. Function keys
4. Digit fields
5. Ventilator quick keys
6. Gas quick keys
7. Split screen values

Anesthesia system display

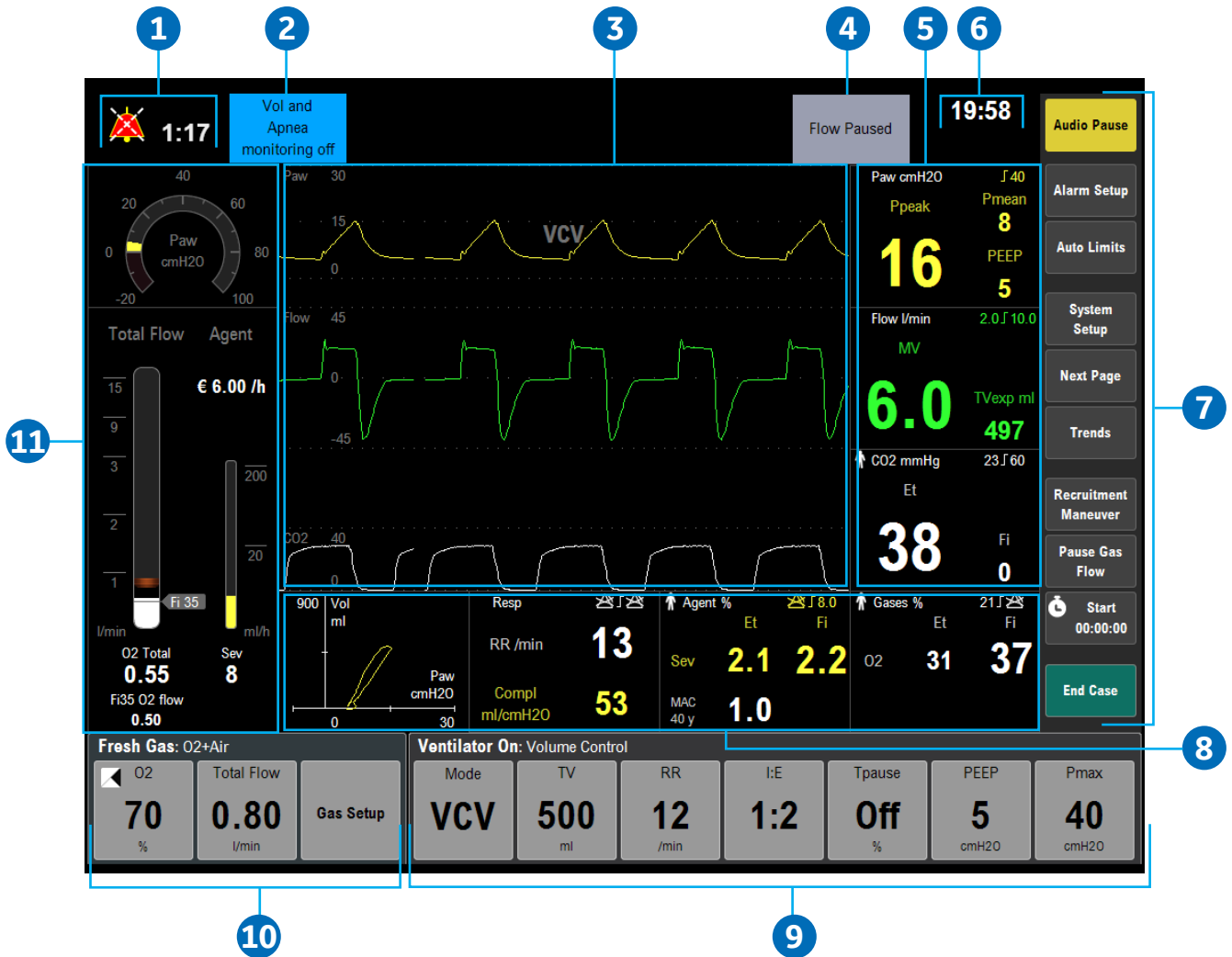

1. **Audio pause symbol and countdown clock:** Indicates when alarm audio is paused and the countdown clock until audio is on.
2. **Alarm message fields:** Displays the active alarms.
3. **Waveform fields:** Displays the waveforms of measured values.
4. **General message fields or lock touchscreen indicator:** Displays general messages and the touchscreen lock indicator.
5. **Measured values fields:** Displays the measured values.
6. **Clock:** Displays the current time.
7. **Function keys:** Select functions such as Audio Pause, Trends, etc.
8. **Digit fields:** Contains information for Spirometry, Resp, Agent, and Gases.
9. **Ventilator quick keys:** Displays Mode, associated ventilation parameters, and More Settings. The selected ventilation mode will be displayed directly above the quick keys.
10. **Gas quick keys:** Displays O₂, Total Flow, and Gas Setup.
11. **Split screen:** Contains airway pressure, gas flow values, compliance, trends, and optional ecoFLOW information.

Using menus

- 1. Menu:** Displays the title of the open menu. For example: Start Case.
- 2. Menu items:** The menu items will vary depending on the selected menu.
- 3. Instructions or help information:** This shows any additional instructions or help messages.

The screenshot shows a dark-themed interface titled "Start Case". A blue box highlights the main menu area, which contains several settings:

- Case Defaults:** A dropdown menu currently set to "ADULT".
- Volume Apnea Alarm:** A dropdown menu set to "On".
- CO2 Alarms:** A dropdown menu set to "On".
- Age:** A text input field containing "40".
- Ideal Weight:** A text input field containing "70".

At the bottom of the interface, there is a large empty rectangular area (indicated by callout 3) and a green button labeled "Start Case Now".

Using the ComWheel

Use the ComWheel to scroll through the quick key settings and function keys, make selections, change settings, and confirm settings.

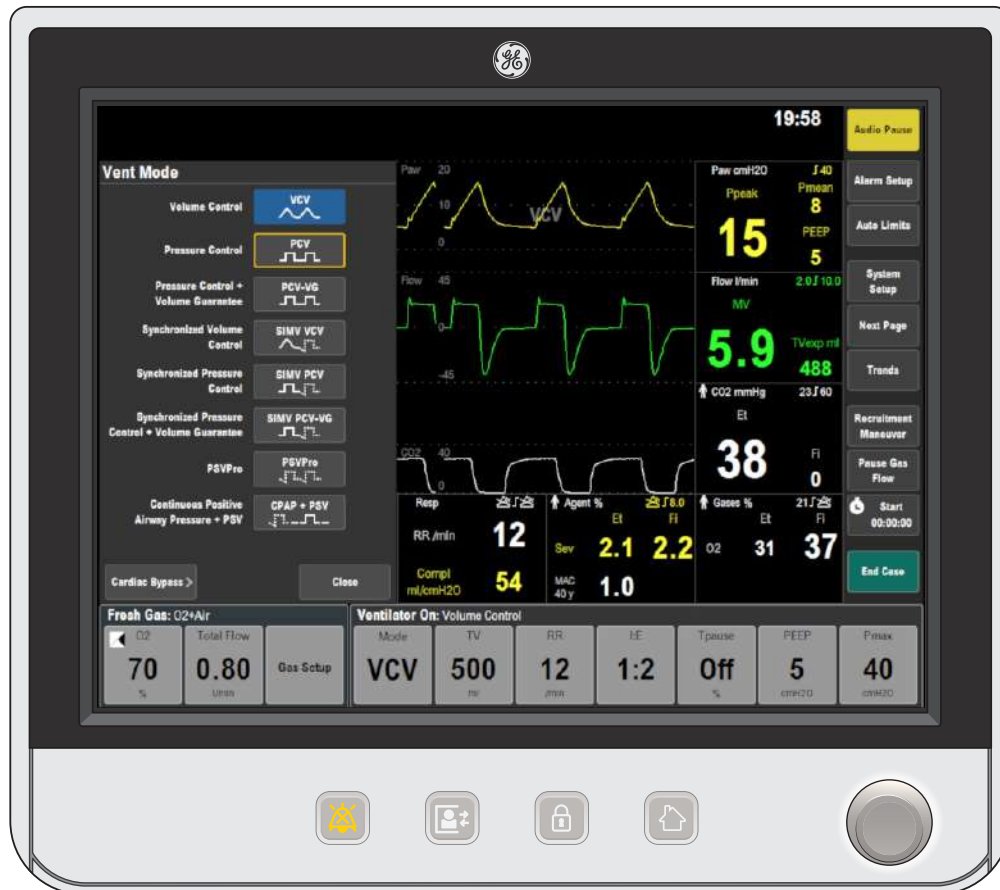

Turn the ComWheel to the right:

- For menu items, the highlight moves down
- For quick keys, the highlight moves to the next key on the right
- For settings, the value changes to the next available setting
- For pull-down selections, the highlight moves to the next available selection
- Push the ComWheel to confirm a setting

Turn the ComWheel to the left:

- For menu items, the highlight moves up
- For quick keys, the highlight moves to the next key on the left
- For settings, the value changes to the previous available setting
- For pull-down selections, the highlight moves to the previous available selection
- Push the ComWheel to confirm a setting

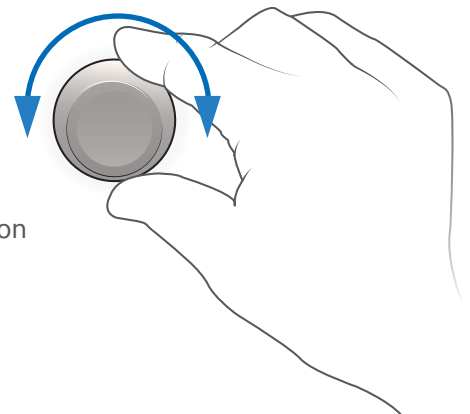

Using quick keys

The gas settings and the main ventilator settings for each ventilation mode can be changed using the quick keys.

1. Select a quick key to open the menu or select a parameter.
2. If **O₂**, **Total Flow**, **Gas Setup**, **Mode** or **More Settings** is selected, a menu displays. Select the desired value on the menu by touching the value. If any other quick key is selected, the value displays with a highlight. Turn the ComWheel left or right to set the desired value.
3. Push the ComWheel or select the quick key to confirm the change.

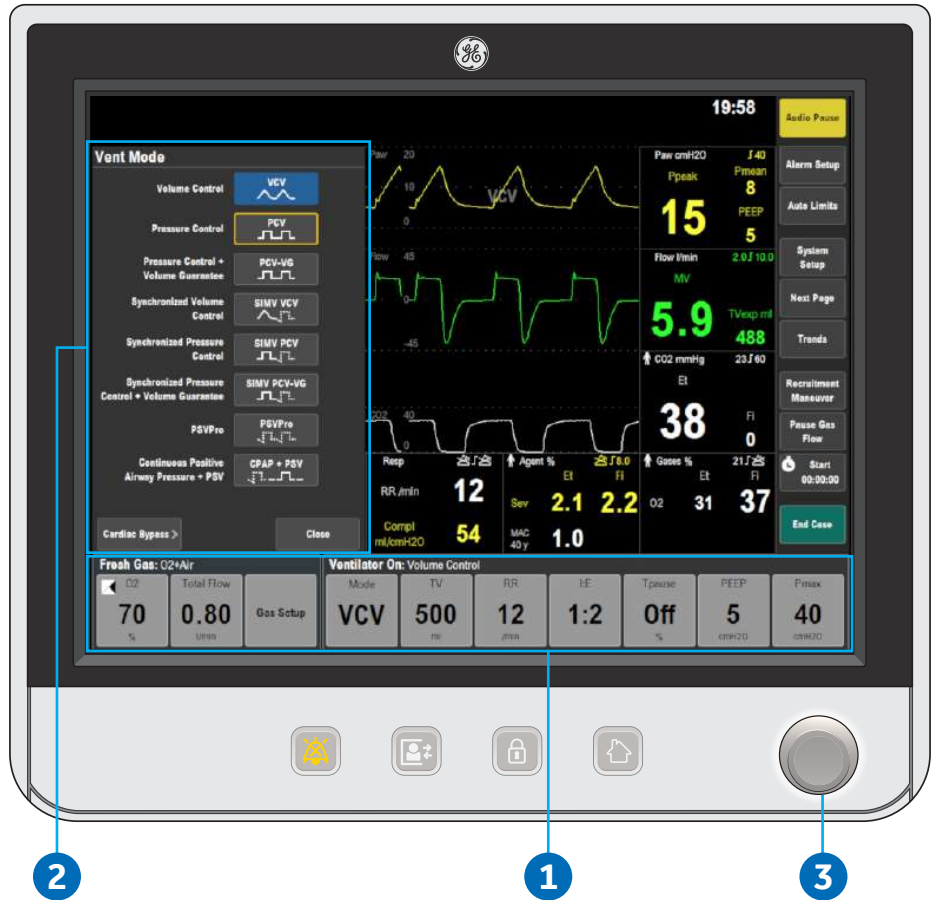

03 Operation overview

Turning on the system

Plug the power cord into an electrical outlet.

1. Make sure the mains indicator light is on.
 - The mains indicator is lit when AC power is connected
 - Battery is charging if it is not already fully charged
2. Push the **On/Standby** switch for 1 second to turn on the system.

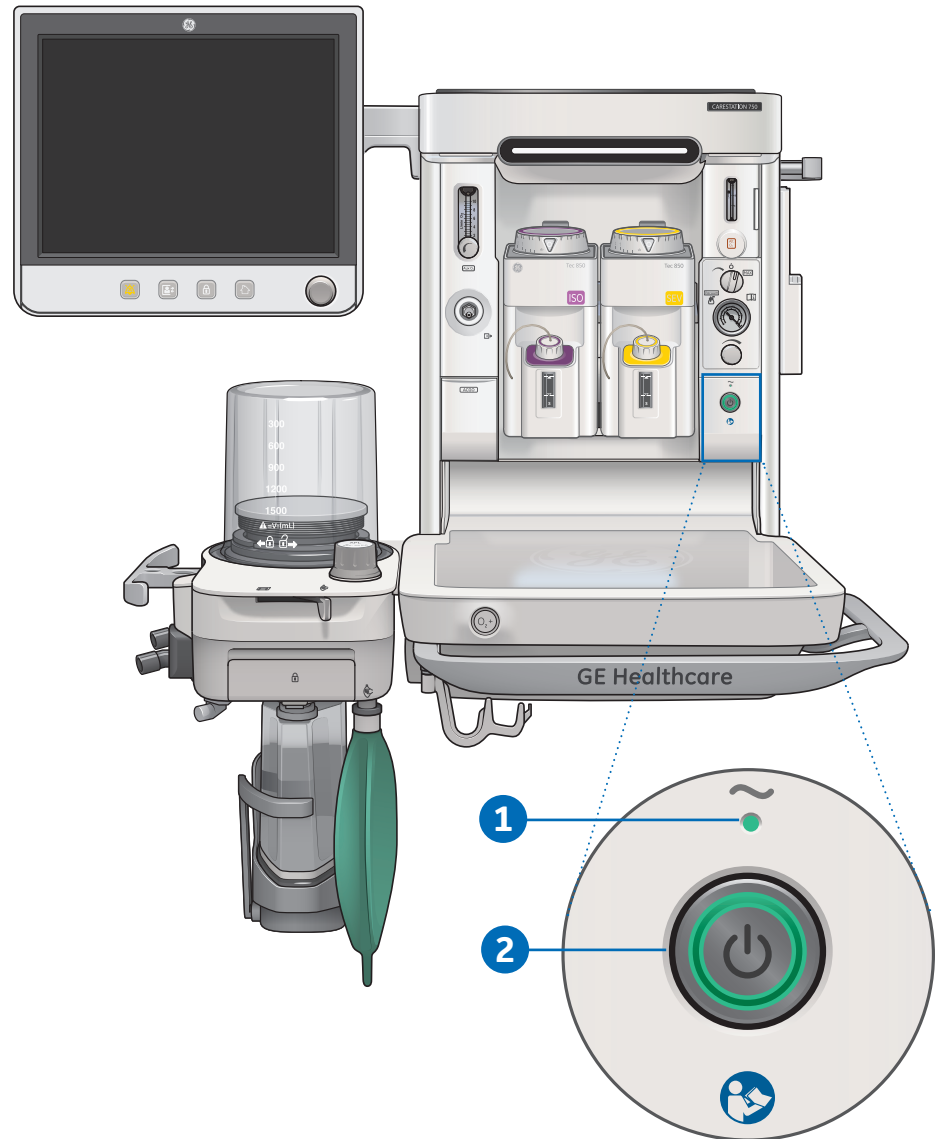

Changing gas settings

1. Select the **Gas Setup** quick key.
2. For **Other Gas**, select the menu item and change using the drop-down menu.
3. For **O₂%**, and **Total Flow**, select the setting and make the change using the ComWheel and push to confirm the setting.

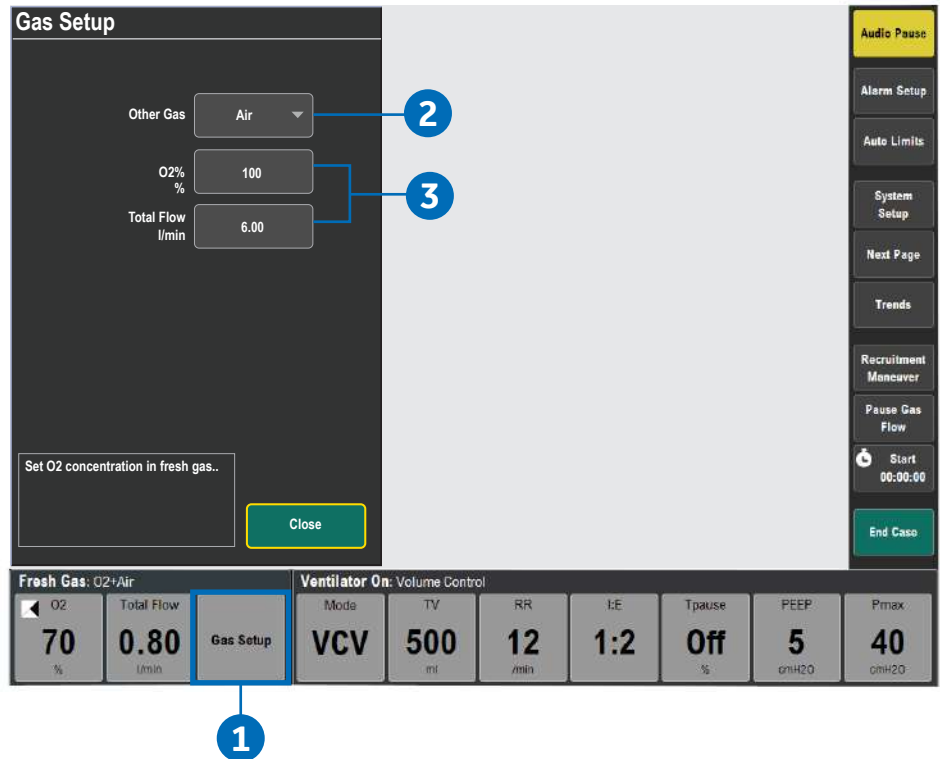

Using the O₂ flush button

The O₂ flush button supplies a high flow of O₂ to the breathing system.

1. Push the **O₂ flush** button to deliver a high flow of O₂.
2. Release the **O₂ flush** button to stop the delivery of a high flow of O₂.

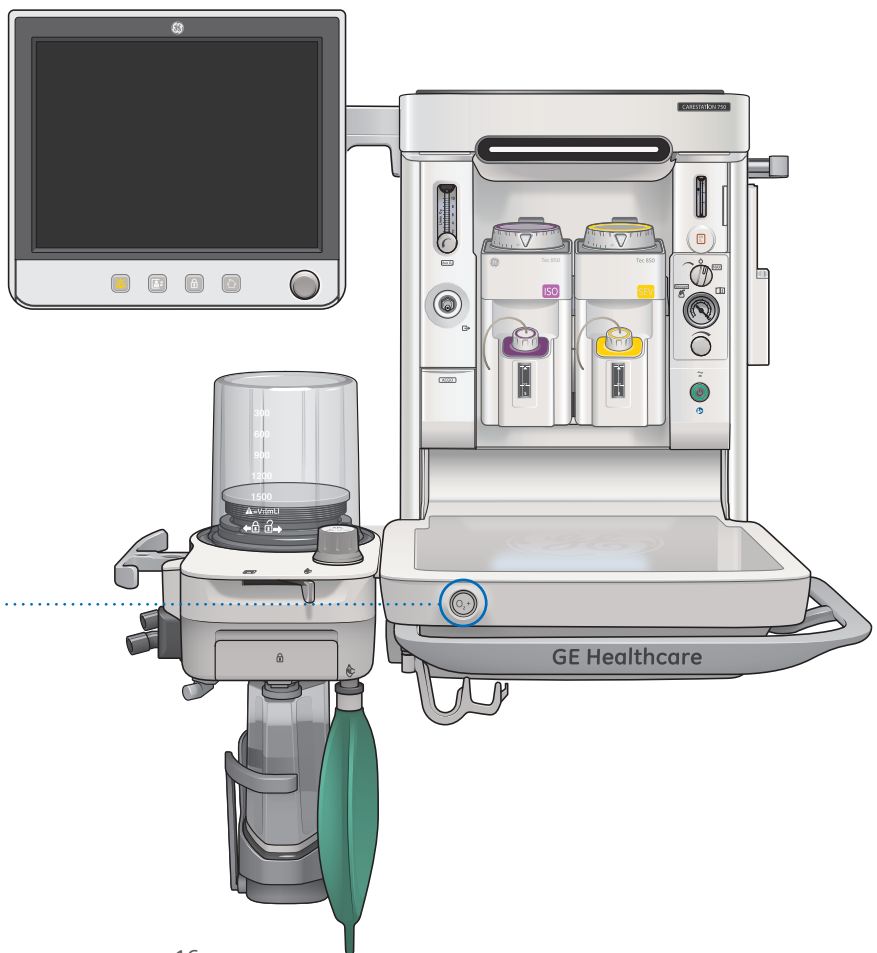
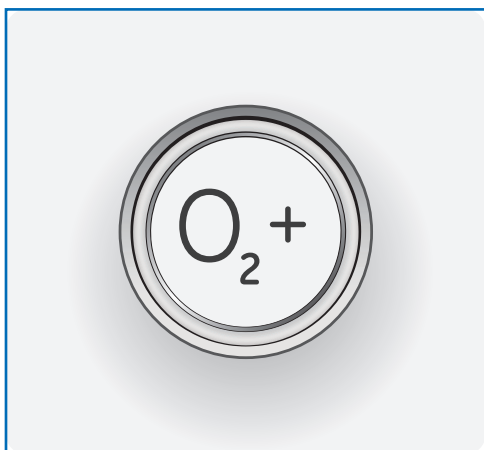

Using the APL valve

The Adjustable Pressure-Limiting (APL) Valve adjusts the breathing system pressure limit during manual ventilation.

Turn the APL valve clockwise to increase the pressure limit, turn the APL valve counterclockwise to decrease the pressure limit.

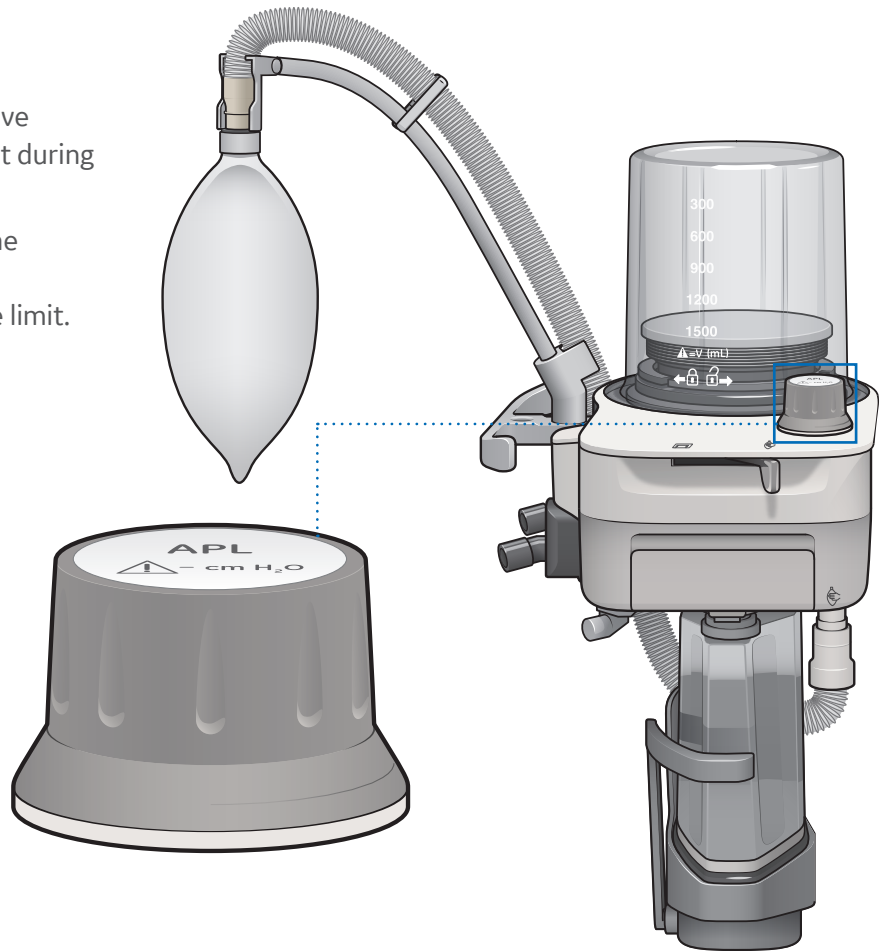

Using the Bag/Vent switch

The Bag/Vent Switch selects between manual ventilation (bag) and mechanical ventilation (ventilator).

1. Slide the switch to the left for **mechanical ventilation**.
2. Slide the switch to the right for **manual ventilation**.

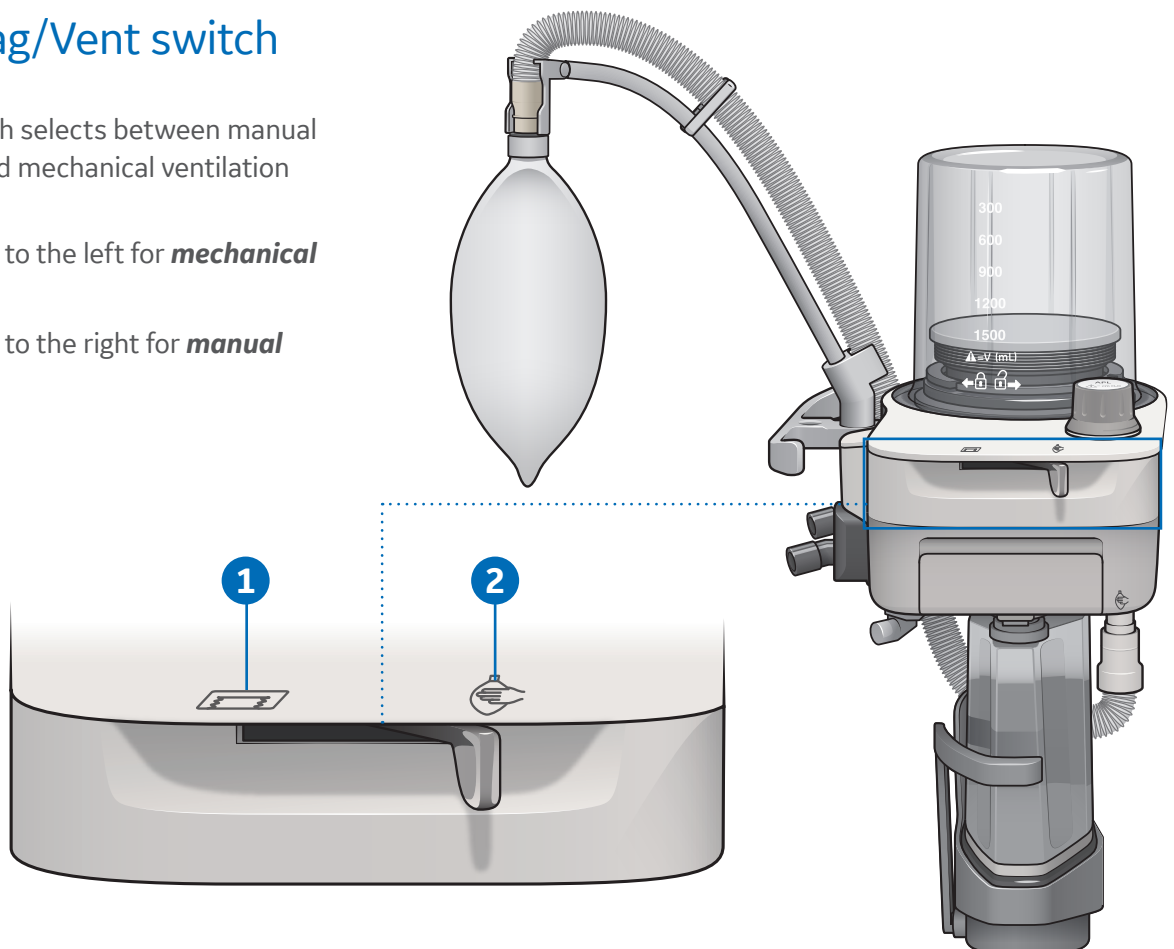

Using the vaporizer

Use only Selectatec™ Series Vaporizers Tec™ 6 Plus Vaporizer or greater.

1. Turn the lock lever full clockwise to lock the vaporizer in position.
2. Push the release and turn the concentration control to set the agent concentration.

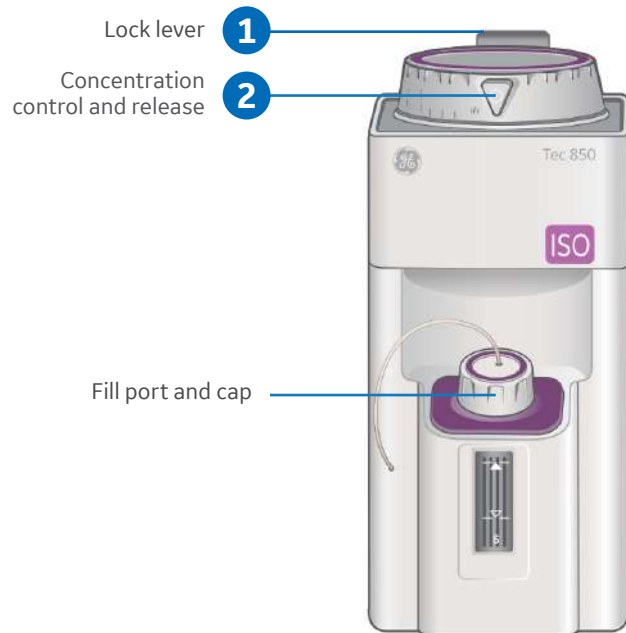

Using the ACGO

1. Open the ACGO switch cover.
2. Set the ACGO switch to the ACGO position.
 - Fresh gas flows through the ACGO port.
 - Fresh gas oxygen concentration is displayed on the screen if the system has the airway module option.
3. Set the alarm limits to clinically appropriate settings.
4. To stop fresh gas flow through the ACGO port, set the ACGO switch to the circle circuit position.

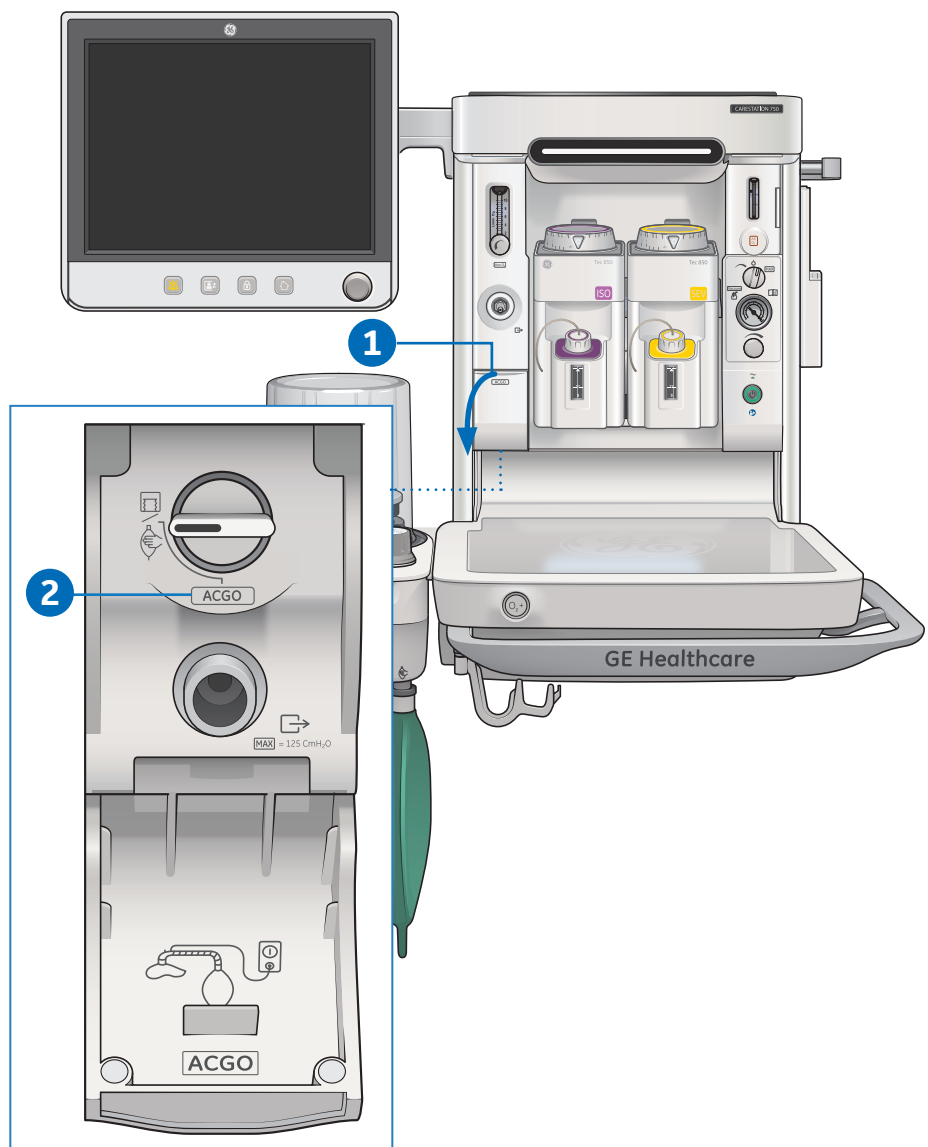

Using Aux O₂+Air

Use the optional Auxiliary O₂+Air (Aux O₂+Air) switch to deliver O₂ and Air through the Aux O₂+Air outlet on the front of the system. No anesthetic agent is delivered through the Aux O₂+Air outlet. When the switch is set to the Aux O₂+Air position during a case, the outlet indicator is lit and N₂O flow is automatically shut off. The Aux O₂+Air outlet provides 100% O₂ or a mixture of O₂ and Air. Select Gas quick keys to adjust the O₂ concentration and total flow.

1. Open the Aux O₂+Air switch cover.
2. Set the Aux O₂+Air switch to the Aux O₂+Air position.
3. Adjust O₂ and Air with selected Gas quick keys.
 - Set O₂%, the default is 100%
 - Set Total Flow, the default is the case default
 - With individual gas control, set the O₂ and Air flow separately
4. Set the switch to the circle circuit position to stop fresh gas flow through the Aux O₂+Air outlet.
 - Total flow or individual flows from Aux O₂ + Air remain
 - Air as Other gas remains

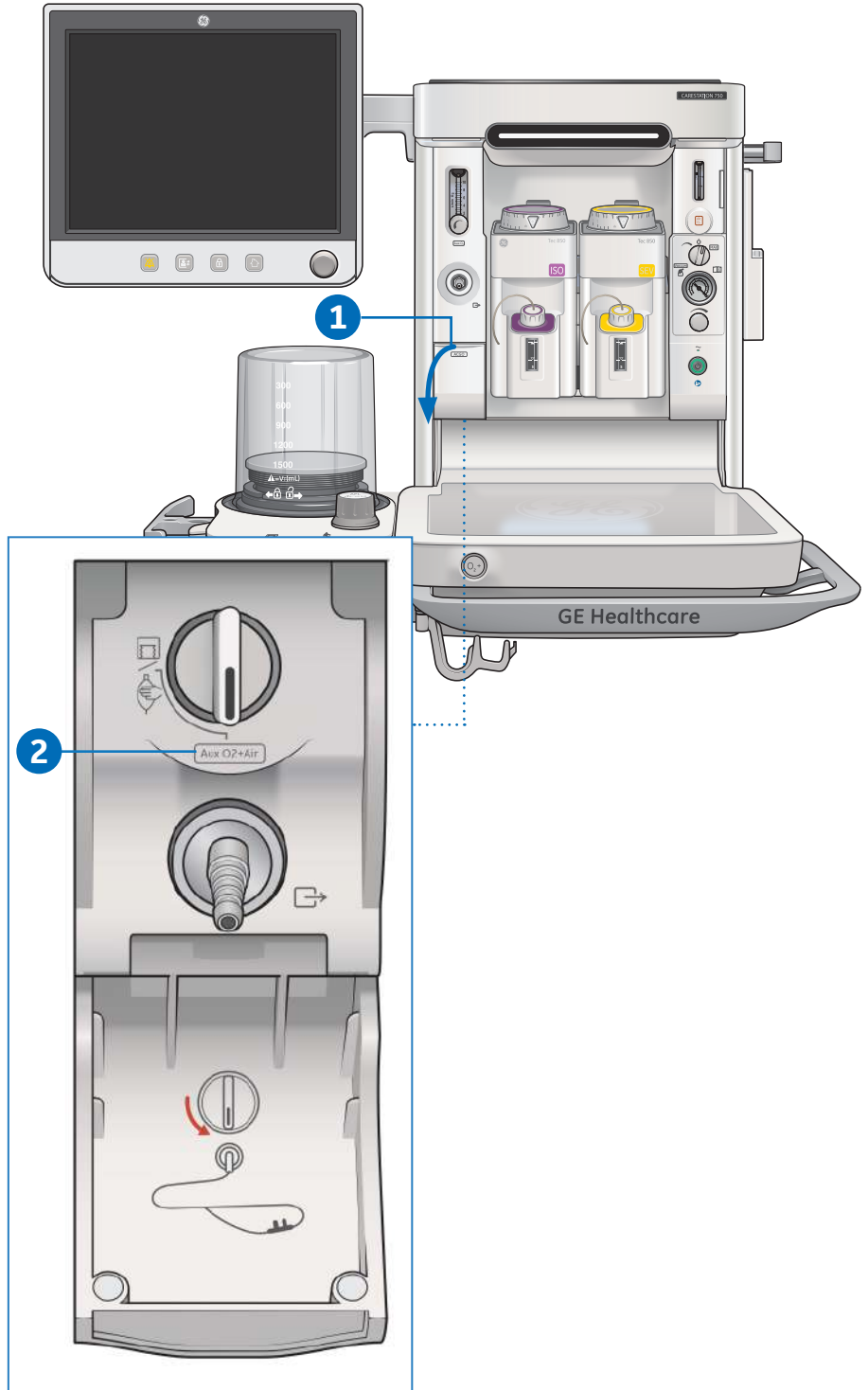

04 Checkout

Checkout overview

The Checkout menu shows on the display after turning on the system. To access the Checkout menu between cases, select **Checkout**. Step-by-step instructions show in the Checkout menu during the tests. Use the Checkout menu to:

- Perform a **Full Test**
- Perform any of the individual tests
- View the **Test Log**
- Start a case

Perform the **Full Test** at the start of each day. The full test runs automatically and beeps to indicate when it is finished or if interaction is required.

The **Full Test** or the individual tests must be performed at least once within every 24-hour period.

Checkout

Full Test

Individual Tests

- Vent and Gas
- Vaporizer Leak
- Circuit Leak
- Calibration
- Start Case

Instructions

⚠ Perform the Checkout prior to use. Do not start a test while the patient is connected.

1. Connect a patient circuit and a manual bag.
2. Check the absorber and the absorbent.
3. Check that the vaporizers are off and filled with agent.
4. Select Full Test and follow the instructions.

Vent and Gas	Pass	15-Jan-2020 19:36
Vaporizer	NA	Not Tested
Circuit Leak	Pass	15-Jan-2020 19:38
Calibration	Last	15-Jan-2020 19:32

Show Log

Checkout full test

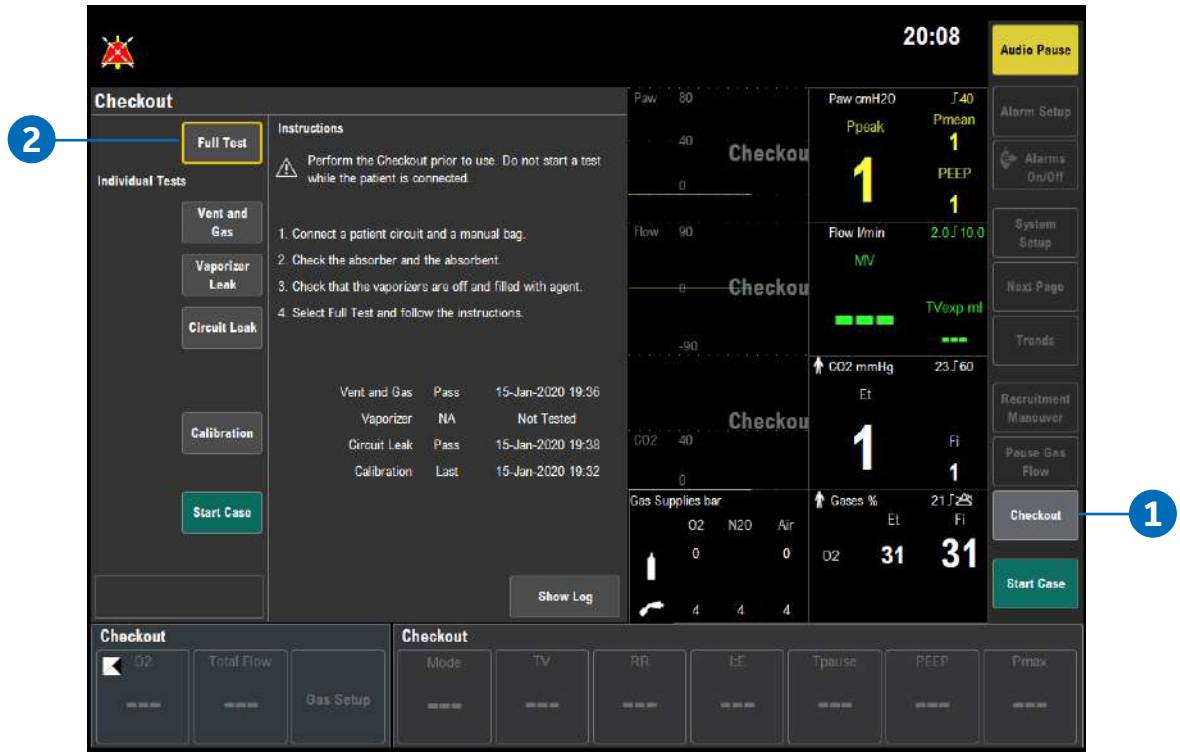

The full test runs automatically and beeps to indicate when it is finished or if interaction is required.

Perform a **Full Test** when any component of the system is changed (breathing system, vaporizers, pipeline inlets).

The **Full Test** does the following tests: **Vent and Gas**, **Vaporizer Leak**, and **Circuit Leak**. When one of the tests is completed, the next test begins.

1. Select **Checkout**.
2. From the Checkout menu, select **Full Test** and follow the instructions.

If a test fails, follow the instructions to perform a retest or accept the results, or select **Help** to follow the troubleshooting tips to check the problem.

Note: In case of a patient emergency, the **Full Test** may be bypassed by selecting **Start Case** and then selecting **Bypass**. The general message **Please Do Checkout** is displayed if a **Full Test** or all of the individual tests are not completed with passing results within **24** hours. The messages **Checkout has not passed** and **Checkout bypass will be recorded to the system log** and will be displayed in Checkout menu when checkout is bypassed.

05 Starting a case

Start Case menu overview

Note: A super user is an authorized personnel who has been trained and qualified to change default settings.

Use the **Start Case** menu to set the case data and start the case. A case can be started using default settings or using custom settings. The default settings are configured by the Super User.

Default Settings selection shows the first of five default case types when the **Start Case** menu is accessed. The **Ideal Weight**, **Age**, and **Volume Apnea Alarm** values are set to the pre-selected settings defined by the Super User corresponding to the case type.

The screenshot displays the 'Start Case' menu interface. At the top, the title 'Start Case' is shown. Below it, there are several configuration options:

- Case Defaults:** A dropdown menu currently set to 'ADULT'.
- Volume Apnea Alarm:** A dropdown menu currently set to 'On'.
- CO2 Alarms:** A dropdown menu currently set to 'On'.
- Age:** A text input field containing the value '40'.
- Ideal Weight:** A text input field containing the value '70'.

At the bottom right of the interface, there is a prominent green button labeled 'Start Case Now' with a yellow border. A large, empty rectangular box is visible at the bottom left of the interface.

Starting a case using default settings

Case Defaults contain five case type selections. Each case type has preset values for **Ideal Weight**, **Age**, and **Volume Apnea Alarm**. The first four default case types are configured and named by the Super User. The fifth default case is **Last Case**.

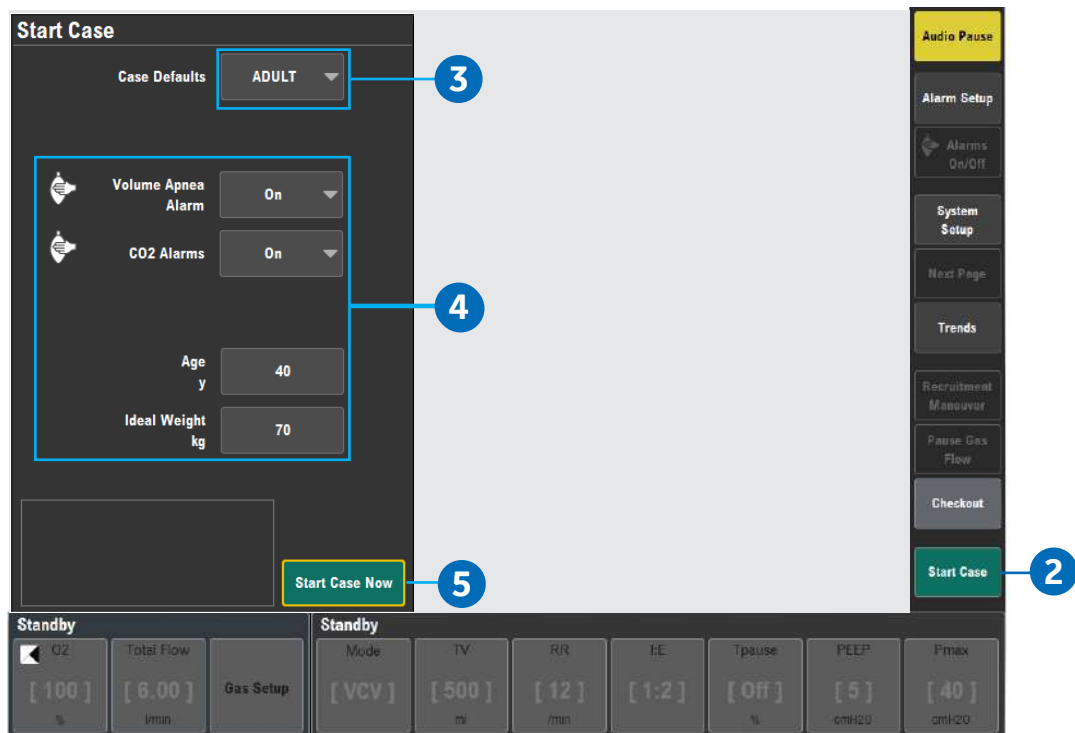

1. Set the Bag/Vent switch to Bag.
2. Select **Start Case**.
 - The **Case Defaults** selection shows the first preset case type
 - **Ideal Weight**, **Age**, **CO2 Alarms**, and **Volume Apnea** Alarm show the default settings that correspond to the case type shown
3. Verify or change the **Case Defaults** selected.
4. Verify the settings are clinically appropriate.
5. Select **Start Case Now**. Gas flow starts.

Starting a case using custom settings

Ideal Weight, Age, CO₂ Alarms, and Volume Apnea Alarm can be custom set on the **Start Case** menu before starting a case.

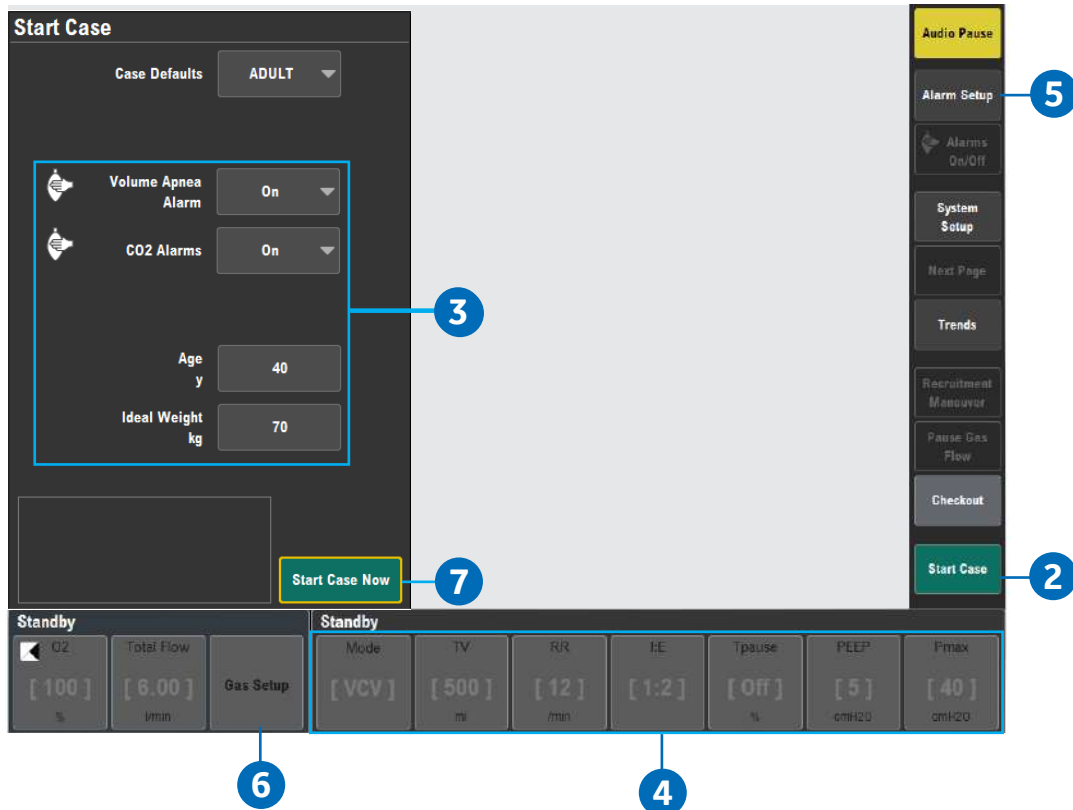

1. Set the Bag/Vent switch to Bag.
2. Select **Start Case**.
 - The **Case Defaults** selection shows the first preset case type
 - **Ideal Weight, Age, CO₂ Alarms, and Volume Apnea Alarm** show the default settings that correspond to the case type shown
3. Change **Ideal Weight, Age, or Volume Apnea Alarm** settings on the menu.
 - The **Case Defaults** changes from the case name to **Preset**
 - If the **CO₂ Alarms** setting on the menu is changed, the **Case Defaults** remains as previously selected
4. To change ventilation mode, select **Mode** and make the change. To change the ventilation settings, select a ventilator quick key or **More Settings** and make the change.
5. To change alarm settings, select **Alarm Setup** and make the change.
6. To change the gas settings or the circuit type, select **Gas Setup** and make the change.
7. From the **Start Case** menu, select **Start Case Now**. Gas flow starts.

Starting manual ventilation

1. Connect a manual breathing circuit.
2. Make sure the APL valve is set to a clinically appropriate value.
3. Set the Bag/Vent switch to **Bag**.

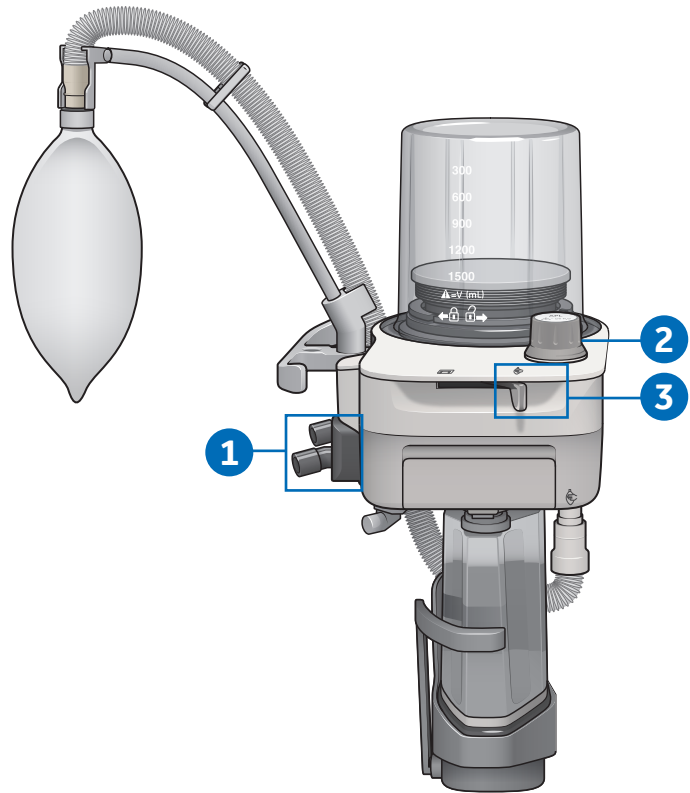

Starting mechanical ventilation

1. Set the ACGO switch to the circle circuit position.
2. Set the Bag/Vent switch.
If Bag/Vent switch is set to Bag, move to Vent position to start mechanical ventilation.
3. If needed, push the O₂ flush button to inflate the bellows.

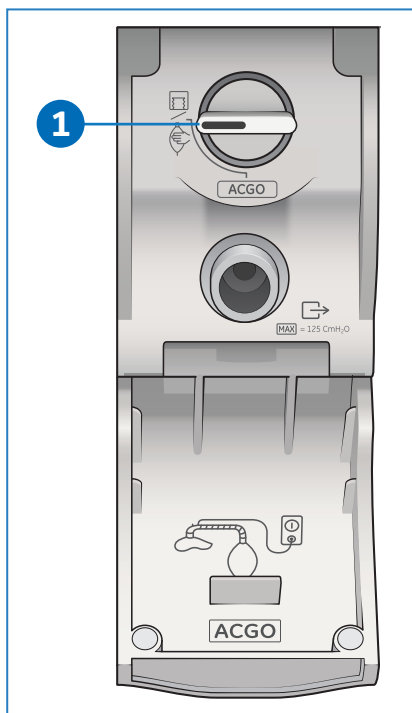
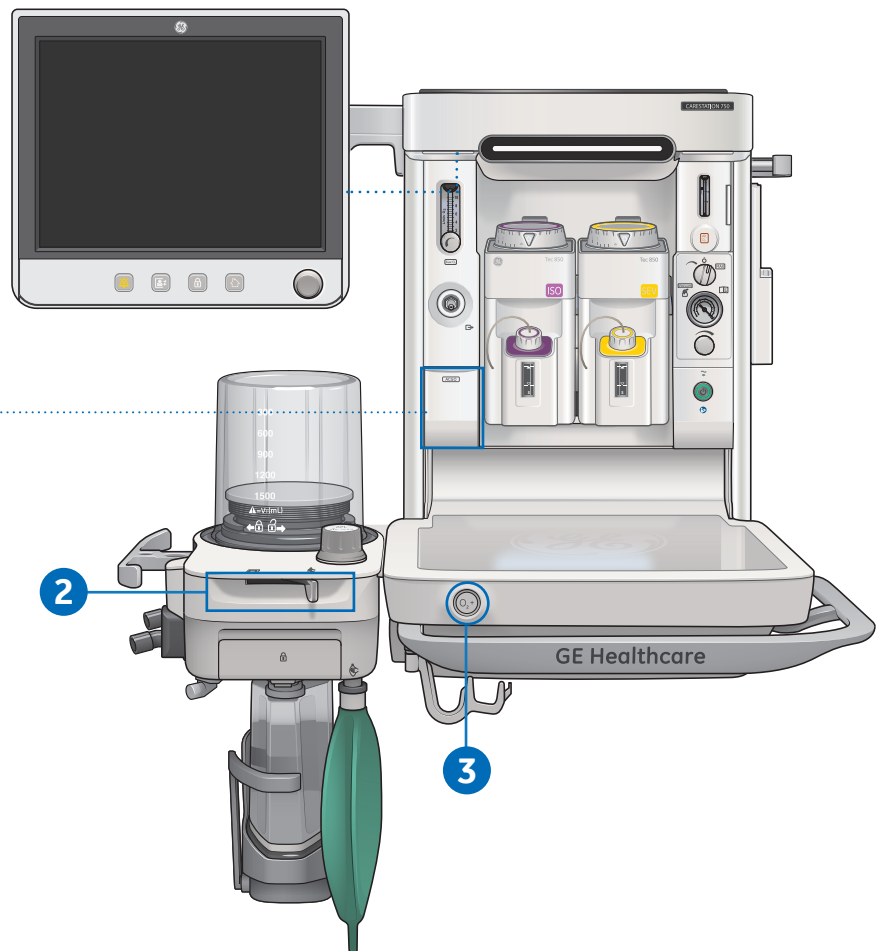

Changing a ventilator mode and settings

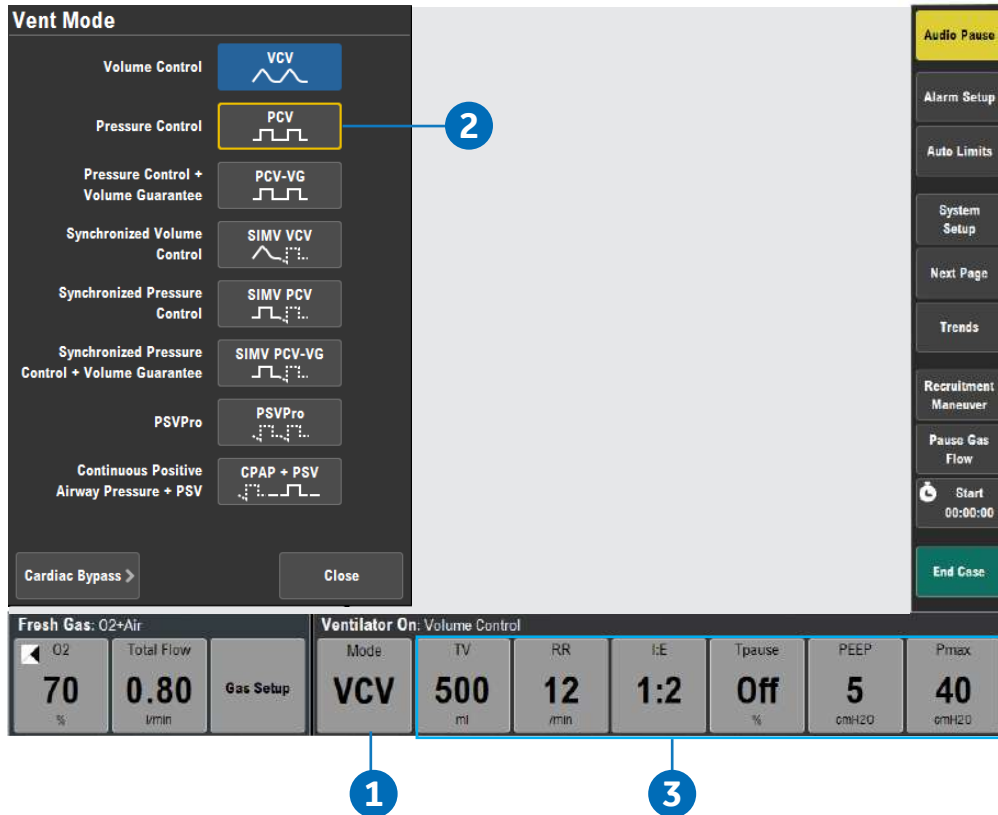

To change a vent mode:

1. Select the **Mode** quick key. The **Vent Mode** menu shows.
2. Select the desired ventilation mode. Set and confirm the primary ventilation setting to activate the ventilation mode.
3. Controls that are frequently used in the ventilation mode can be adjusted with the ventilator quick keys and the **More Settings** quick key. **To change a ventilator setting:** Select the ventilation setting to be adjusted. Set the desired value and then push the ComWheel to activate the change.

06 Alarms and Trends

Setting alarm limits

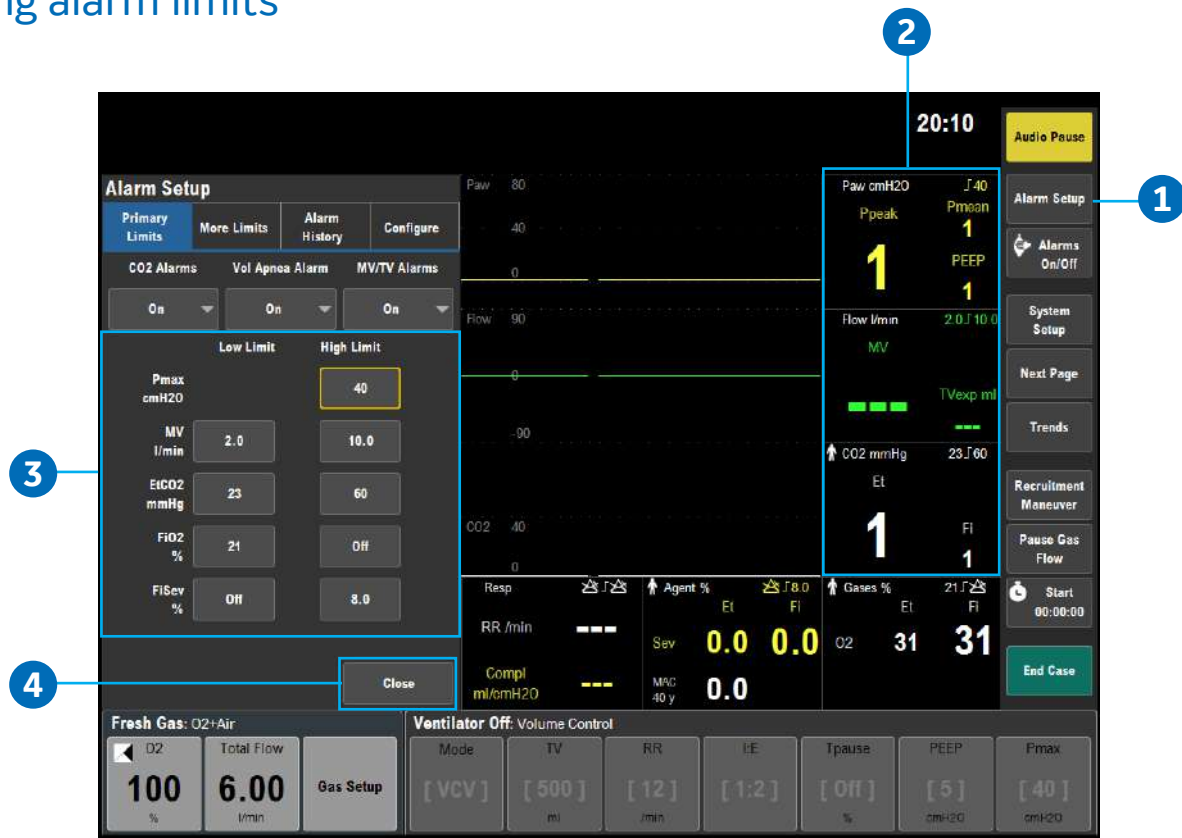

To set an alarm limit:

1. Select **Alarm Setup** or...
2. Select one of the Measured Value fields.
3. From the **Primary Limits** and **More Limits** tabs, select the alarm limit and make the change.
4. Push the **Home** key, touch the waveform area of the display, or select **Close** to close the menu.

Additional alarm settings

The following alarms can be turned off to reduce nuisance alarms during manual ventilation if clinically appropriate:

- 1. CO₂ Alarms:** Use the **CO₂ Alarms** setting to turn off the CO₂ 'Apnea' alarm, **EtCO₂ low**, **EtCO₂ high**, and **FiCO₂ high** and **Absorbent OK?** alarms during manual ventilation.
- 2. Vol Apnea Alarm:** Use the **Vol Apnea Alarm** setting to turn off the volume apnea alarm during manual ventilation.
- 3. MV/TV Alarms:** Use the **MV/TV Alarms** setting to turn off the MV and TV alarms. If **MV/TV Alarms** is set to **Off** during manual ventilation, the alarms remain off until the Bag/Vent switch is set to Vent or the **MV/TV Alarms** is set to **On**. If the **MV/TV Alarms** is set to **Off** during mechanical ventilation, the alarms remain off when manual ventilation starts.

Note: **CO₂ Alarms** and **Apnea Alarm** selection will not be visible unless enabled by a Super User. **CO₂ Alarms** and **Vol Apnea Alarm** can only be turned off while in manual ventilation.

Alarm Setup

Primary Limits | More Limits | Alarm History | Configure

CO₂ Alarms: On | Vol Apnea Alarm: On | MV/TV Alarms: On

	Low Limit	High Limit
Pmax cmH ₂ O		40
MV l/min	2.0	10.0
EtCO ₂ mmHg	23	60
FiO ₂ %	21	Off
FiSev %	Off	8.0

Close

Setting Auto Limits

Use the **Auto Limits** menu to quickly set alarm ranges for 'MV', 'TV', and 'EtCO₂' during mechanical ventilation.

1. Select the **Auto Limits** key. The menu shows the current measured values and the proposed low and high alarm limits. Check the proposed parameters.
2. Select **Confirm** to use the proposed low and high alarm limits.
3. Select **Cancel** to leave the alarm limits unchanged.
4. Select **Case Default Limits** to set the alarm limits to the case default limits.

Auto Limits

	Current Value	Low	High
MV l/min	3.6	1.6	6.0
TV ml	465	Off	700
EtCO ₂ mmHg	36	26	47

Buttons: Cancel, Confirm, Case Default Limits

Bottom Panel: Fresh Gas: O₂+Air (O₂: 70%, Total Flow: 0.80 l/min, Gas Setup), Ventilator On: Volume Control (Mode: VCV, TV: 500 ml, RR: 12 /min, I:E: 1:2, Tpause: Off, PEEP: 5 cmH₂O, Pmax: 40 cmH₂O)

Viewing Trends

Use the **Trends** menu to view patient trends and set the time scale.

1. Select the **Trends** key.
2. Select the desired view.
3. Select **Scroll** to move through the current trend view.
4. Select **Time Scale** to select the desired scale from the dropdown menu.
5. Select **Next Page** to view additional parameters.
6. Select **Close** to close the menu.

Trends

View: Graphical, Measured, Settings

Page 1 Measured Data 16-Jan-2020

Time	O ₂ % Et/Fi	CO ₂ mmHg	AA % Et/Fi	AA ID	N ₂ O% Et/Fi
17:10	41/34	36/1	2.1/2.2	Sev	0/0
17:15	41/34	36/1	2.1/2.2	Sev	0/0
17:20	41/34	36/1	2.1/2.2	Sev	0/0

Page 1 of 3

Buttons: Next Page, Close

Bottom Panel: Fresh Gas: O₂+Air (O₂: 70%, Total Flow: 0.80 l/min, Gas Setup), Ventilator On: Volume Control (Mode: VCV, TV: 500 ml, RR: 12 /min, I:E: 1:2, Tpause: Off, PEEP: 5 cmH₂O, Pmax: 40 cmH₂O)

07 Ventilation modes

Volume control mode (VCV)

- Supplies a set volume to the patient
- Calculates a flow based on the set tidal volume and the length of the inspiratory time
- Can compensate for breathing system compliance, fresh gas flow, and moderate breathing system leaks
- Inspiratory pause is available

VCV mode settings:

- TV
- RR
- I:E
- Tpause
- PEEP
- Pmax

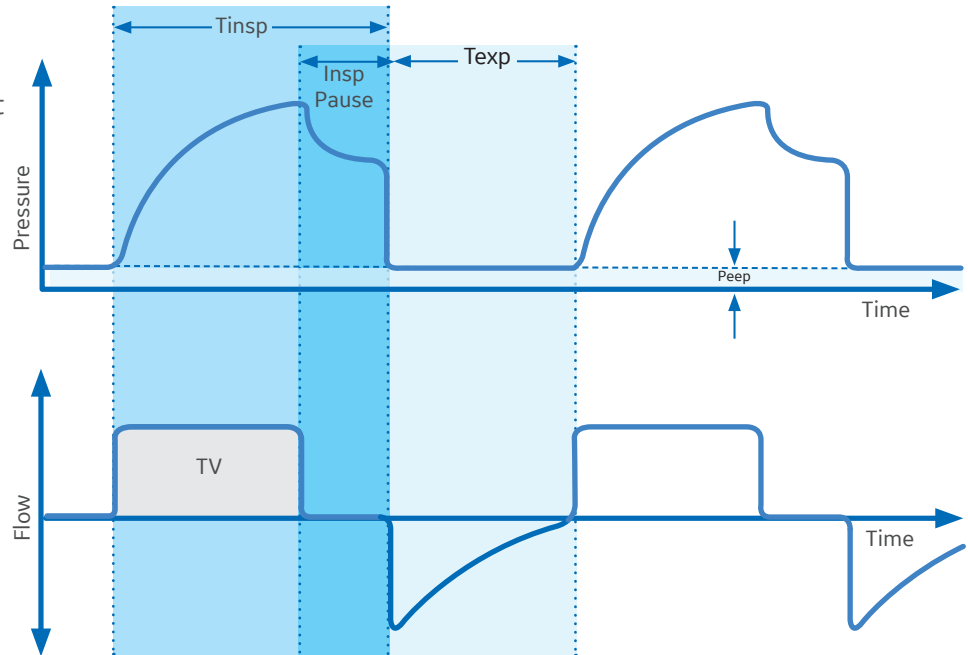

Pressure control mode (PCV)

- Supplies a constant set pressure during inspiration
- Inspiratory time is calculated from the rate and I:E settings
- High initial flow
- Flow is adjusted automatically to maintain set inspiratory pressure

PCV mode settings:

- P_{insp}
- RR
- I:E
- PEEP
- P_{max}
- Rise Rate

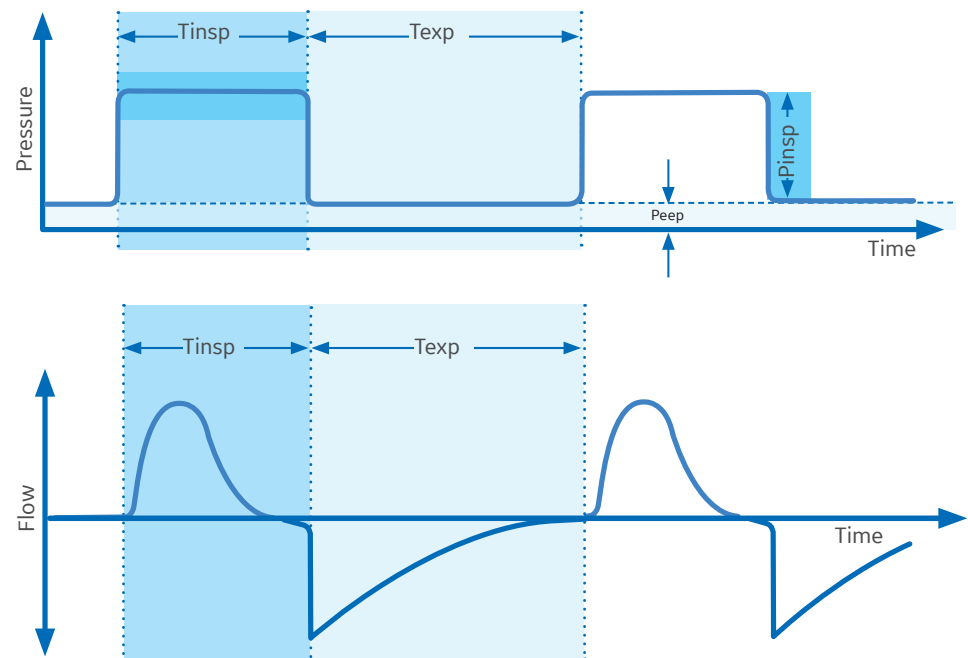

PCV-VG mode

- Tidal volume is set and volume is delivered using a decelerating flow and constant pressure
- The ventilator will adjust the inspiratory pressure needed to deliver the set tidal volume breath-by-breath so that the lowest pressure is used
- The patient's compliance is determined from a volume breath delivered at the set tidal volume, and the inspiratory pressure level is then established for the next PCV-VG

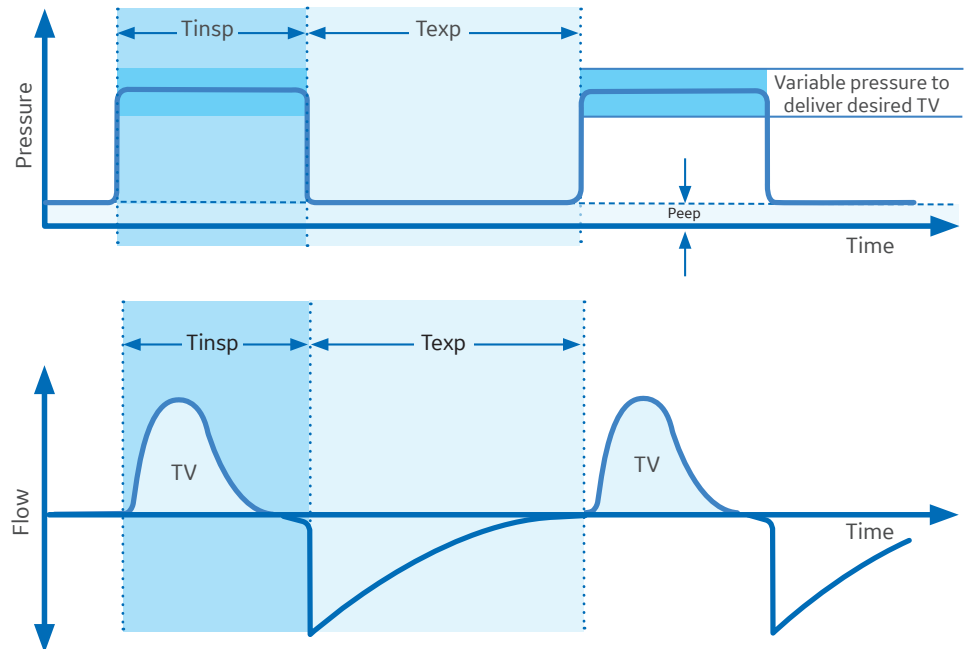

PCV-VG mode settings:

- TV
- RR
- I:E
- PEEP
- Pmax
- Rise Rate

SIMV VCV mode

- Periodic volume breaths are delivered at preset intervals
- Between the machine delivered breaths, the patient can breathe spontaneously
- Spontaneous breaths can be pressure supported
- Spontaneous breaths are indicated by a color change in the waveform

SIMV-VCV mode settings:

- TV
- RR
- T_{insp}
- T_{pause}
- $P_{support}$
- PEEP
- Pmax
- Trig Window
- Flow Trigger
- End of Breath
- Rise Rate

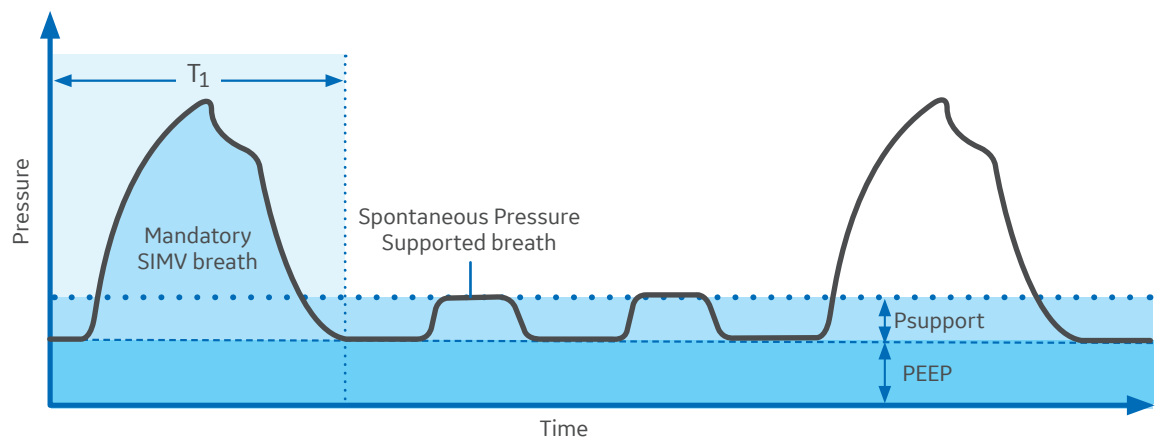

SIMV PCV mode

- Delivers a relatively slow breathing rate with pressure controlled breathing
- Combines mandatory breaths with spontaneous breath support
- If a trigger event occurs within the synchronized window, a new pressure-controlled breath is initiated
- If a trigger event occurs elsewhere during the expiratory phase, a support for a spontaneous breath is provided with pressure support added as set by the clinician.

SIMV PCV mode settings:

- P_{insp}
- RR
- T_{insp}
- P_{support}
- PEEP
- P_{max}
- Trig Window
- Flow Trigger
- End of Breath
- Rise Rate
- Exit Backup

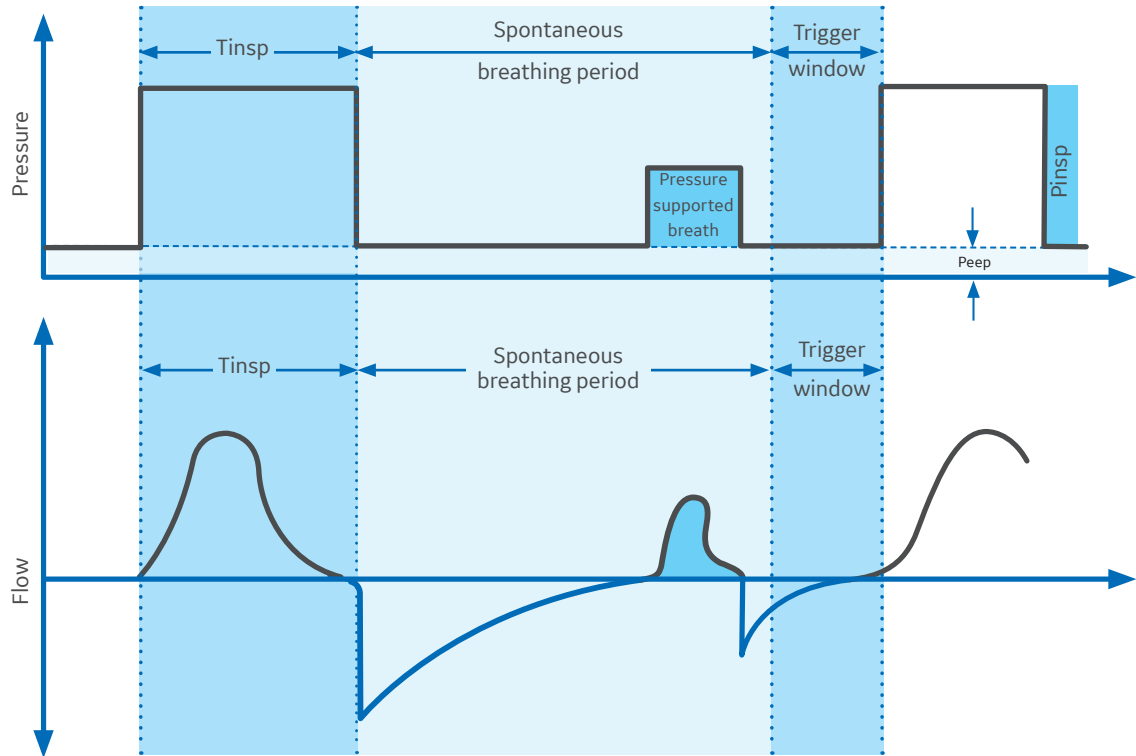

SIMV PCV-VG mode

- Delivers a set rate of pressure controlled breaths with a guaranteed volume
- The ventilator will adjust the inspiratory pressure needed to deliver the set tidal volume breath-by-breath so that the lowest pressure is used.
- The patient's compliance is determined from the volume controlled ventilation breath and the inspiratory pressure level is then established for the next PCV-VG breath.

SIMV PCV-VG mode settings:

- TV
- RR
- Flow Trigger
- P_{support}
- PEEP
- T_{insp}
- P_{max}
- Trig Window
- End of Breath
- Rise Rate
- PSV Rise Rate

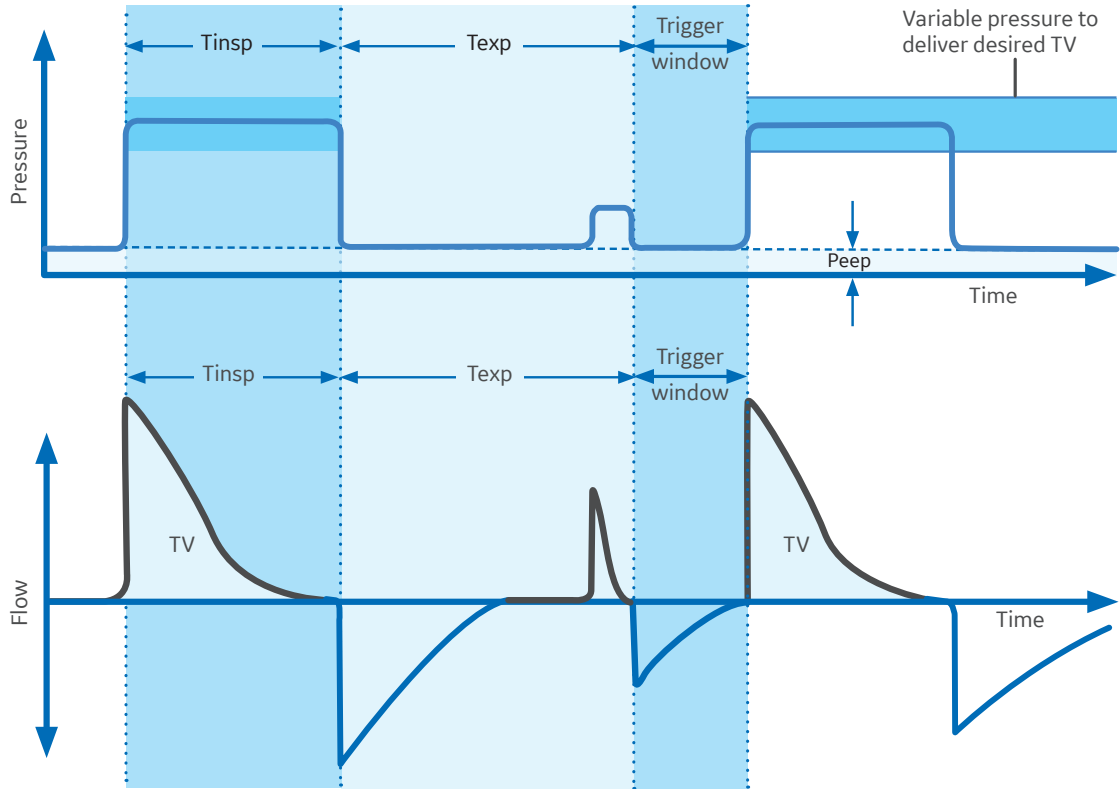

PSVPro™ Ventilation Mode

- Pressure supported ventilation with apnea backup
- Clinician sets the P_{support} and PEEP levels, the patient establishes the rate, inspiratory flow and inspiratory time
- Tidal volume is determined by the pressure, lung characteristics and patient effort
- Apnea backup mode (SIMV PCV) is provided if the patient stops breathing
- In backup mode, the Backup Mode active alarm is shown until PSVPro™ Ventilation Mode is reinstated or another ventilation mode is selected

PSVPro mode settings:

- P_{support}
- PEEP
- Trig Window
- Flow Trigger
- End of Breath
- P_{max}
- Backup Time
- P_{insp}
- RR
- T_{insp}
- Rise Rate
- Exit Backup

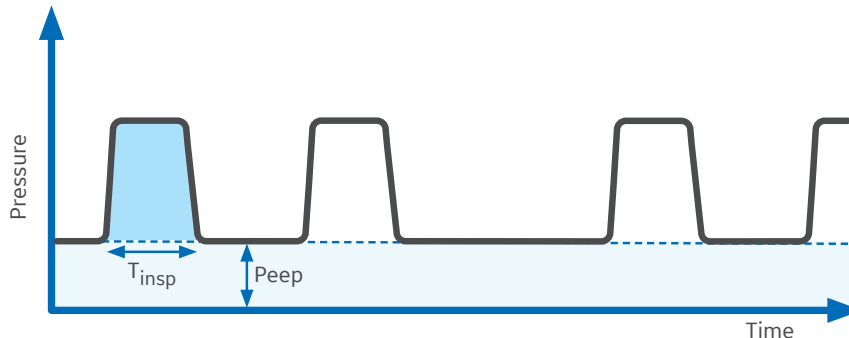

CPAP + PSV mode

- Provides a constant support pressure for spontaneously breathing patients once the ventilator senses an inspiratory effort
- The patient establishes the rate, inspiratory flow, and inspiratory time
- The tidal volume is determined by the pressure, lung characteristics, and patient effort.
- Spontaneous breaths that occur are indicated by a color change in the waveform

CPAP + PSV settings:

- P_{support}
- PEEP
- Flow Trigger
- End of Breath
- P_{max}
- P_{insp}
- Minimum RR
- T_{insp}
- Rise Rate

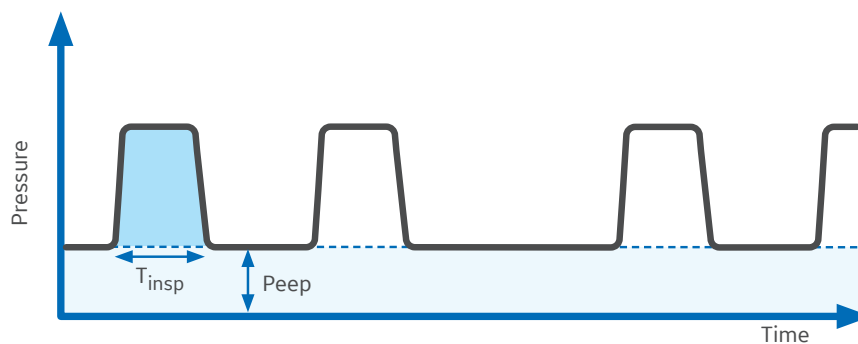

08 Special features

ecoFLOW overview

The ecoFLOW option provides a split screen view that shows the approximate minimum O₂ flow to maintain a preset FiO₂ value. It also shows the approximate agent used per hour and the cost.

The split screen shows the Paw gauge in the upper area and the ecoFLOW gauge in the lower portion of the screen. The ecoFLOW gauge consists of a fresh gas flow tube, an agent flow indicator, and related parameters.

Below the fresh gas flow tube is the measured total O₂ flow to the patient and the calculated FiO₂ flow value. The FiO₂ flow value is based on the FiO₂ setting specified by a Super User. This is the minimum O₂ flow needed to deliver a preset inspired O₂ concentration. O₂ Total flow greater than the Fi25 O₂ flow represents excess flow which can be reduced, while still maintaining desired FiO₂ preset value. The FiO₂ flow value is specific to each patient and case.

The agent flow indicator shows the amount of liquid agent flow as related to the fresh gas setting. The calculated cost of the agent shows above this indicator. This cost is based on agent flow and the values entered in the Super User mode.

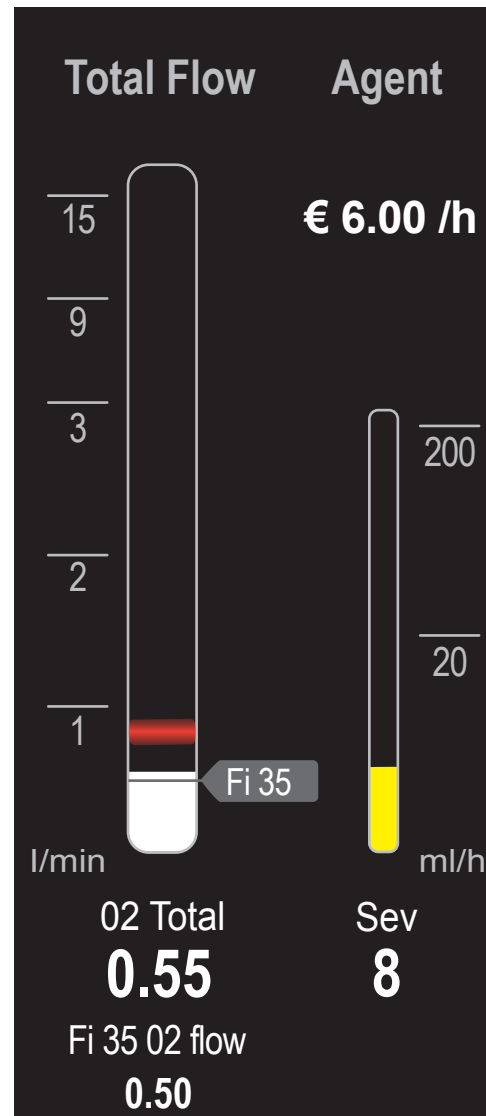

ecoFLOW menu components

1. **Agent:** Shows Agent cost and flow information.
2. **Agent Cost:** The cost of the current agent flow. This value is determined by the agent flow multiplied by the agent cost set by the Super User.
3. **FiO₂ flow marker:** The graphical representation on the flow tube of the FiO₂ flow value. This marker can be removed by the Super User
4. **Agent flow:** The measured value of the liquid agent flow from the vaporizer. The agent flow may have a delayed response.
5. **FiO₂ flow:** The minimum O₂ flow needed to maintain the set inspired O₂ flow. This item can be disabled by the Super User.
6. **O₂ total (numeric):** The O₂ total equals the set of O₂ flow. If N₂O is the balance gas, this equals the set O₂ flow. If Air is the balance gas, this is the set of O₂ flow plus 21% of the Air flow.
7. **O₂ total (graphical):** The graphical representation of the total O₂ flow.
8. **N₂O total and N₂ total:** The N₂O total equals the set N₂O flow. The N₂ total equals the N₂ in the Air flow.
9. **Flow bobbin:** The height of this represents the total fresh gas flow delivered to the breathing system.
10. **Total flow:** Shows Total Flow information.

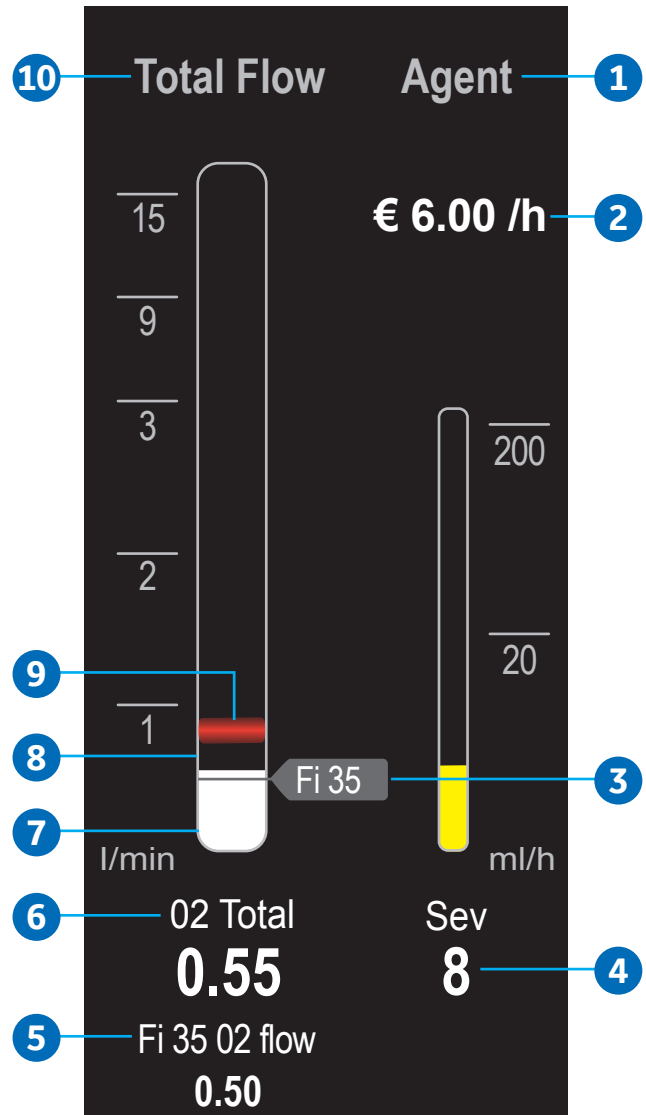

Activating the ecoFLOW split screen

1. Select **System Setup > Screen Setup**.
2. Select the **Layout** tab.
3. Select Split Screen and select **ecoFLOW** from the drop-down menu.
4. Select **Close**.

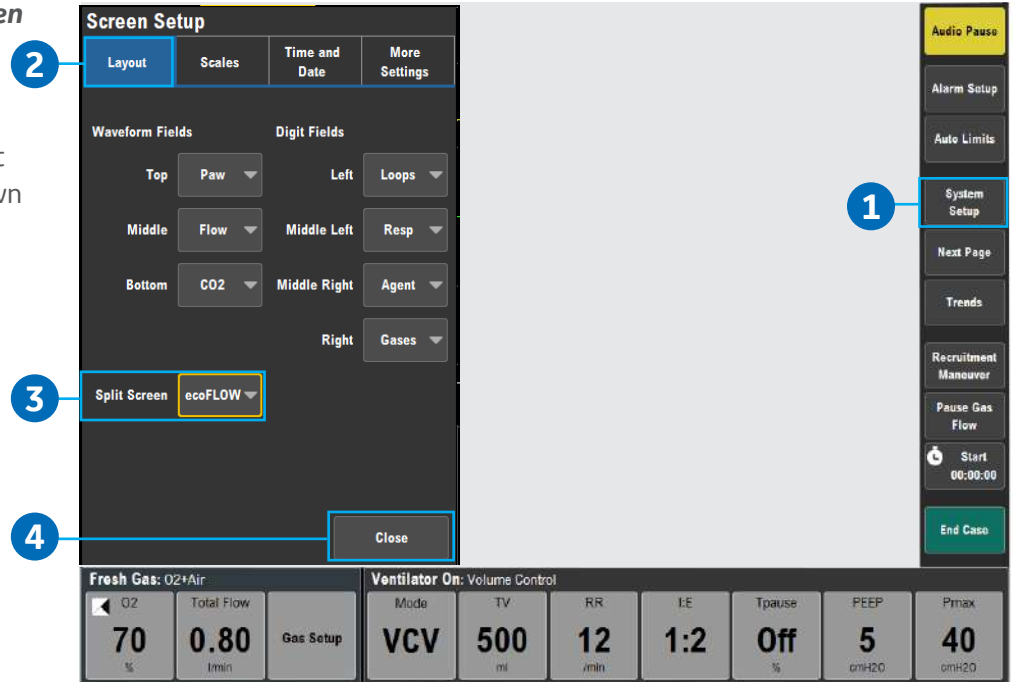

Recruitment Maneuver

Use the Single Step recruitment maneuver to deliver a pressure breath for a set time during mechanical ventilation, without making multiple ventilator setting changes.

Use the Multi Step recruitment maneuver to deliver pressure breaths through a series of ventilation steps during mechanical ventilation, without making multiple ventilator setting changes.

1. Select **Recruitment Maneuver**.
2. Select **Single Step** or **Multi Step**.
3. Adjust any required settings.
4. Select **Start Maneuver**. Stop maneuver anytime by selecting **Stop Maneuver**.
5. Select **Close**.

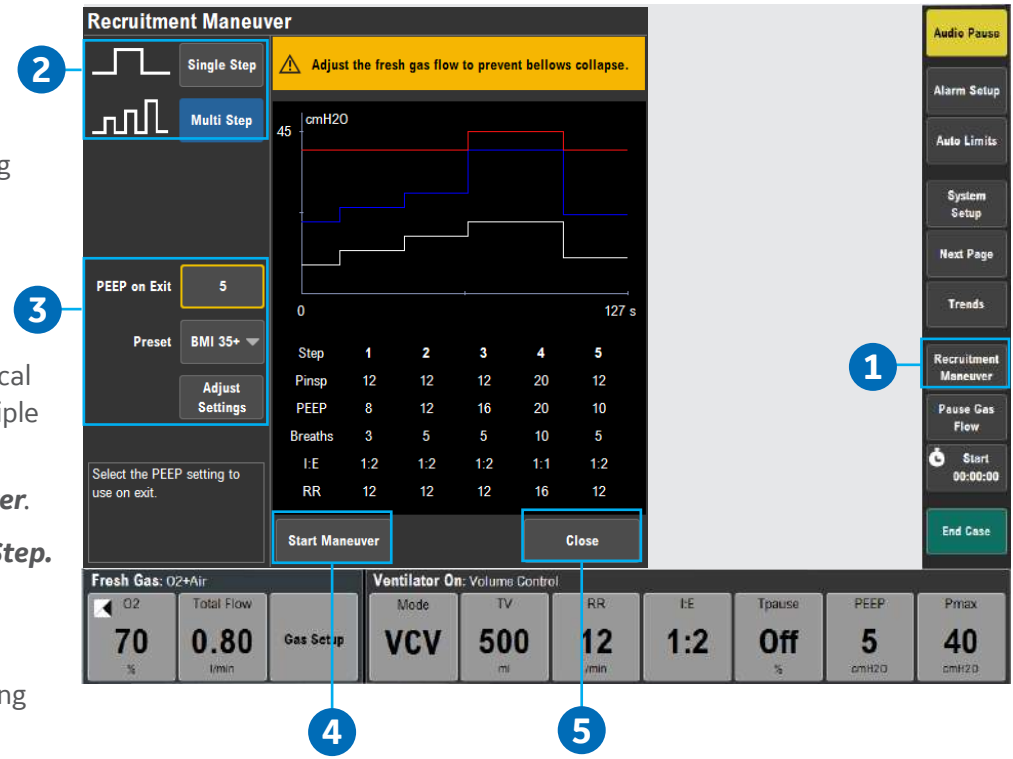

Note: The image shown is for the **Multi Step** maneuver only.

Pause Gas Flow

Use Pause Gas Flow to temporarily suspend the flow of gas during a case. Using Pause Gas Flow while the breathing circuit is disconnected prevents the flow of gas into the room. Pause Gas Flow is available during both mechanical ventilation and manual ventilation.

1. Select the **Pause Gas Flow** function key, and then select **Pause Gas Flow** from the Pause Gas Flow menu.
2. The amount of time remaining in the gas flow pause shows in the window.
 - Gas flow stops for 1 minute and automatically resumes after 1 minute.
 - If mechanical ventilation is on, mechanical ventilation stops for 1 minute and then automatically resumes after 1 minute.
3. Resume the flow of gas at any time during the pause by selecting **Restart Gas Flow**.

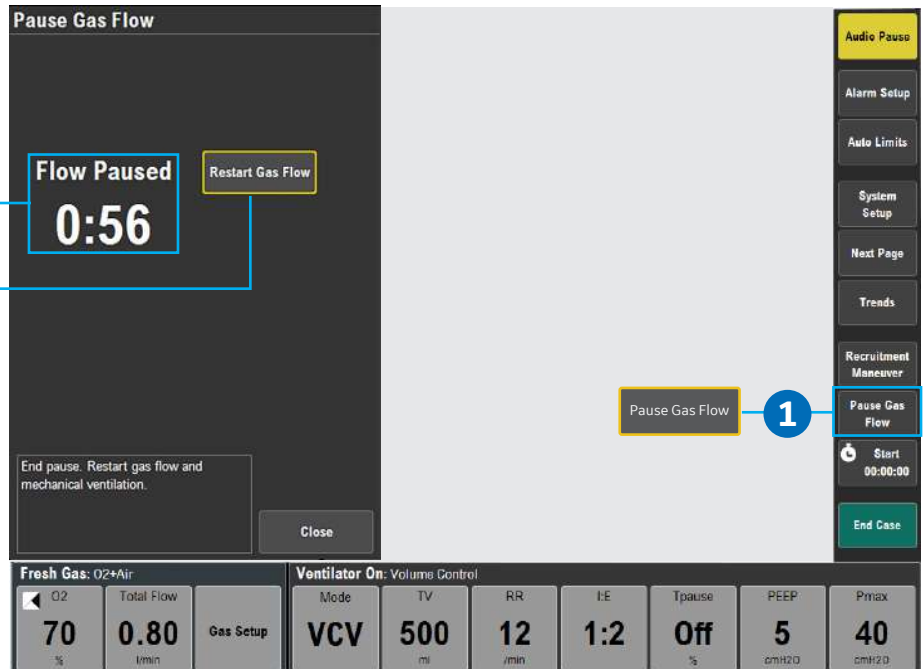

Spirometry overview

Use the Spirometry menu to:

- Set the loop type
- Adjust the loop scaling
- Save a loop to memory
- Access the Setup Loops menu
- View a saved loop
- Delete a saved loop

Note: If Spirometry is being displayed in a digit field, you can also access the Spirometry menu by selecting the loop in the digit field.

To activate the Spirometry split screen:

1. Select **System Setup > Screen Setup**.
2. Select the **Layout** tab.
3. Select **Split Screen** and select **Spirometry** from the drop-down menu.
4. Select **Close**.

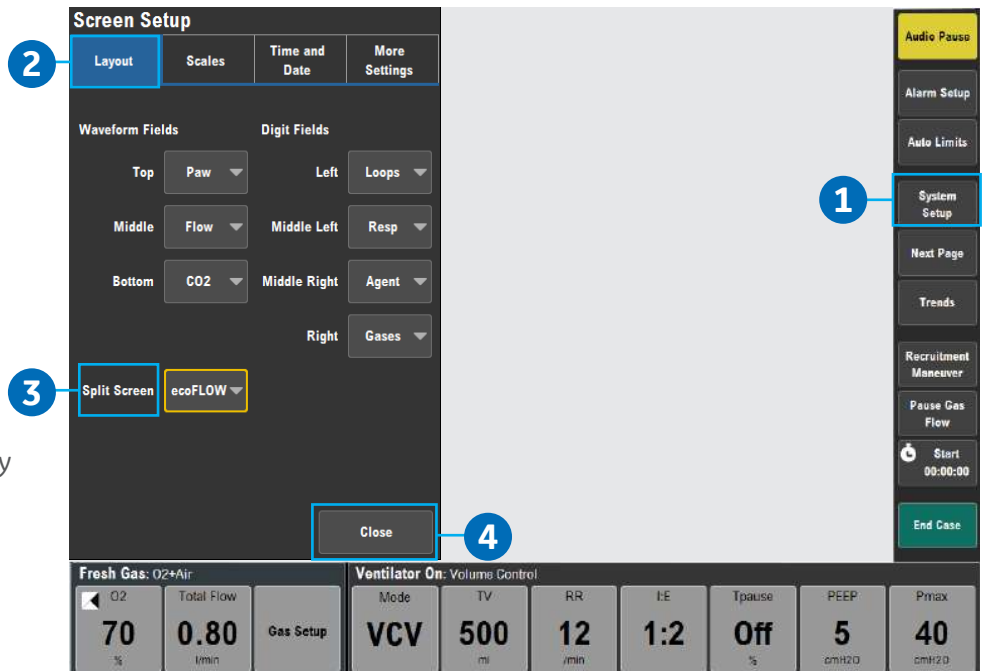

Spirometry loop components

Spirometry loop components:

1. Volume axis
2. Pressure axis
3. Real-time loop (yellow)
4. Reference loop (grey)
5. There are three types of spirometry loops that can be selected from the **Loop Type** drop-down menu: Pressure-Volume (**Paw-Vol**), Flow-Volume (**Flow-Vol**), and Pressure-Flow (**Paw-Flow**).

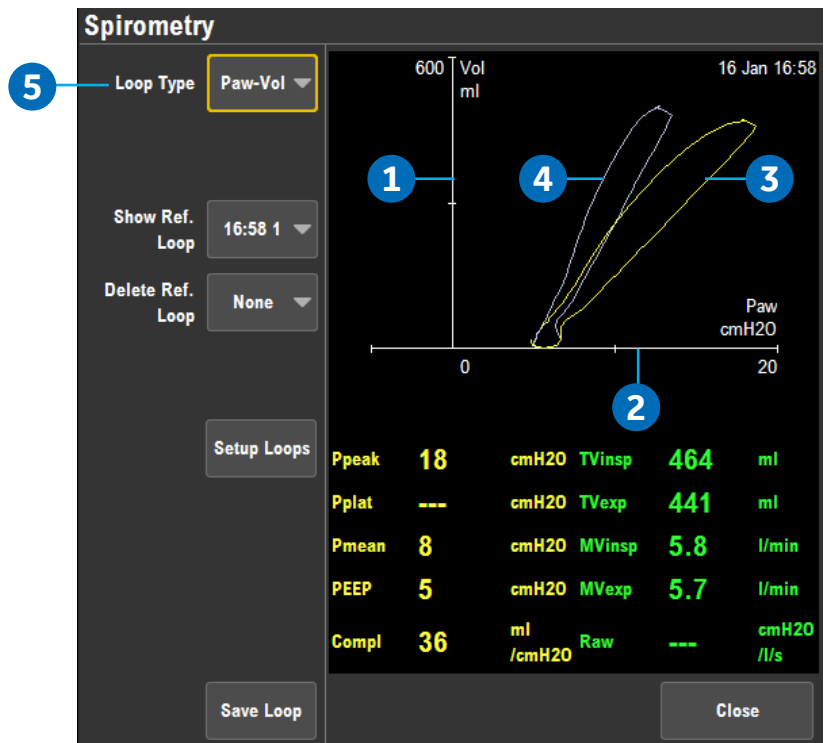

Saving, viewing and deleting spirometry loops

Spirometry loops can be saved, viewed, and deleted through the Spirometry menu.

1. **Save Loop:** To store a loop to memory, select **Save Loop**. Up to six loops can be saved.
2. **Show Ref. Loop:** To view a saved loop, set **Show Ref. Loop** to the time at which it was saved.
3. **Delete Ref Loop:** To delete a saved loop, set **Delete Ref. Loop** to the time at which it was saved.

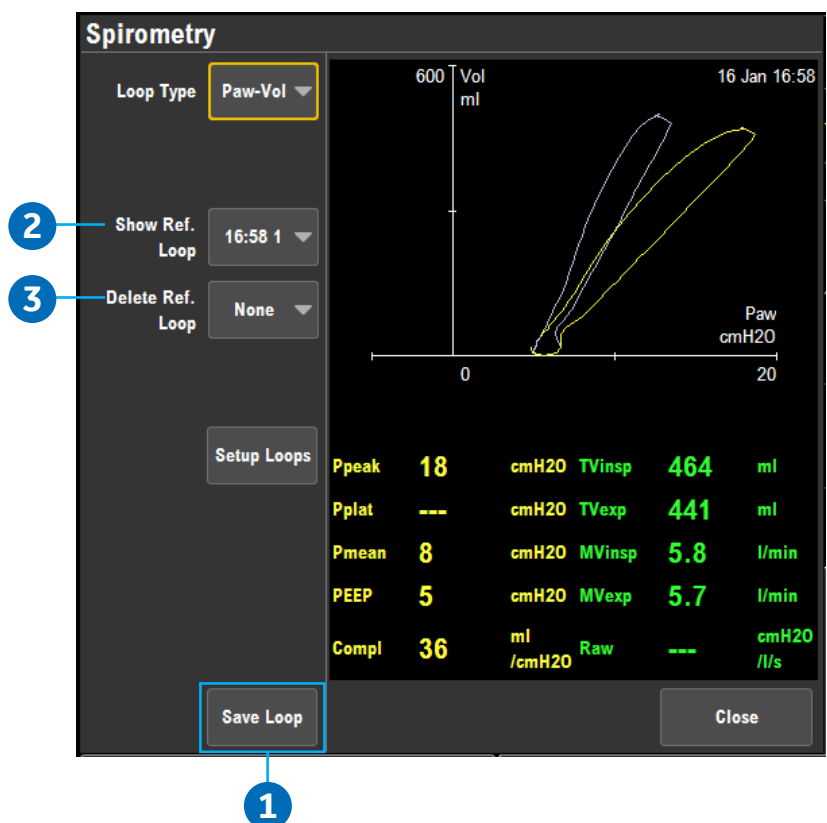

Spirometry setup

Select **Setup Loops** from the Spirometry menu to access the Setup loops menu.

- Spirometry Scaling:** Set the scales of the spirometry loop graph. The available settings for the volume, Paw, and flow graph axis are dependent on the set patient type of adult or pediatric.
 - **Auto:** automatically adjusts the volume, Paw, and flow axis of the loop.
 - **Linked:** links the adjustment of the volume, Paw, and flow axis of the loop graph together.
 - **Indep.** allows the axis of the loop graph to be changed separately for the volume, Paw, and flow axis.
- Patient and Sensor:** Select **Adult** or **Pedi** depending on the sensor used.
- Data Source:** Select **Patient** to have spirometry data sourced from the airway module or **Vent** to have spirometry data sourced from the ventilator.
- Show MV or TV:** Set to **TV** to show TVinsp and TVexp on the spirometry split screen. Set to **MV** to show MVinsp and MVexp on the spirometry split screen.

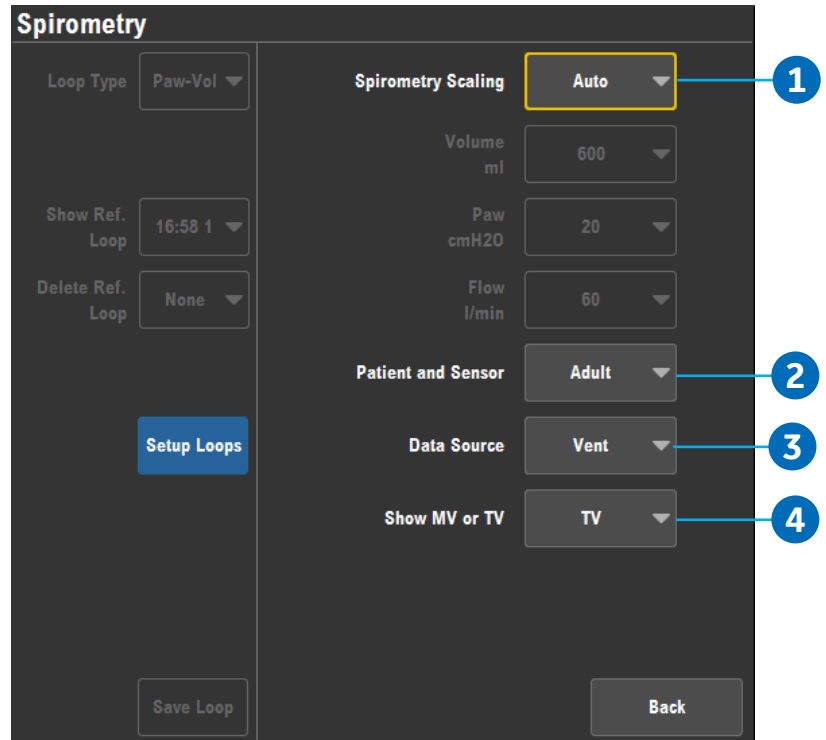

Cardiac Bypass

There are two types of cardiac bypass. Manual ventilation cardiac bypass is standard. VCV cardiac bypass is optional. Manual ventilation cardiac bypass suspends alarms for patients on cardiac bypass when the ventilator is not mechanically ventilating.

Systems with the VCV cardiac bypass option enabled can mechanically ventilate while in VCV mode. The VCV mode is the only ventilation mode available while using VCV cardiac bypass.

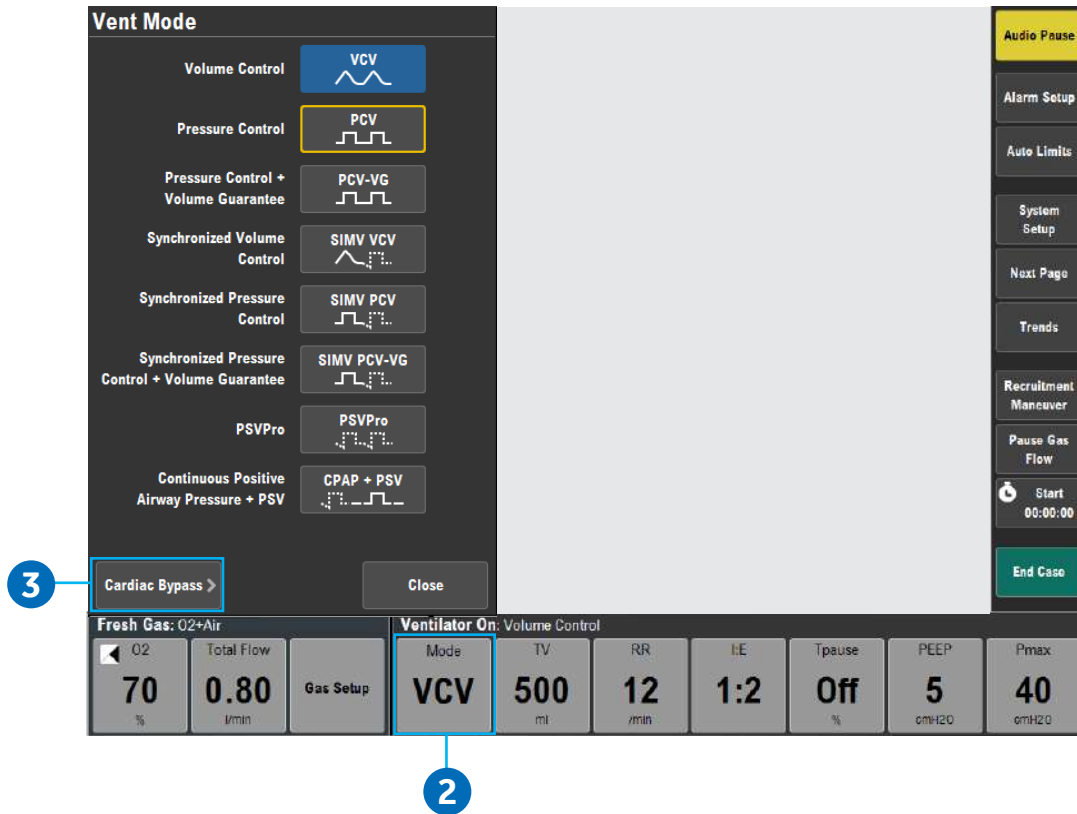

Using Manual Ventilation Cardiac Bypass:

1. Set the Bag/Vent switch to Bag.
2. Select **Ventilation Mode** quick key.
3. Select **Cardiac Bypass**, and then select **Start Cardiac Bypass**. The **Cardiac Bypass** message shows in the waveforms and in the general message field when manual ventilation cardiac bypass is active.

Using VCV Cardiac Bypass:

1. Start mechanical ventilation in VCV mode.
2. Select **Ventilation Mode** quick key.
3. Select **Cardiac Bypass**, and then select **Start Cardiac Bypass**.
 - PEEP is set to 5 cmH₂O
 - TV settings of less than 170 ml prior to starting cardiac bypass remain at the set TV.
 - TV settings of more than 170 ml prior to starting cardiac bypass change to 170 ml.
 - The 'VCV Cardiac Bypass' message shows in the waveforms and in the general message field when VCV cardiac bypass is active.

09 End of Case and Standby

End Case

Use the **End Case** menu to stop gas flow and end the patient alarms. The amount of gas used and agent used during the case shows in the menu.

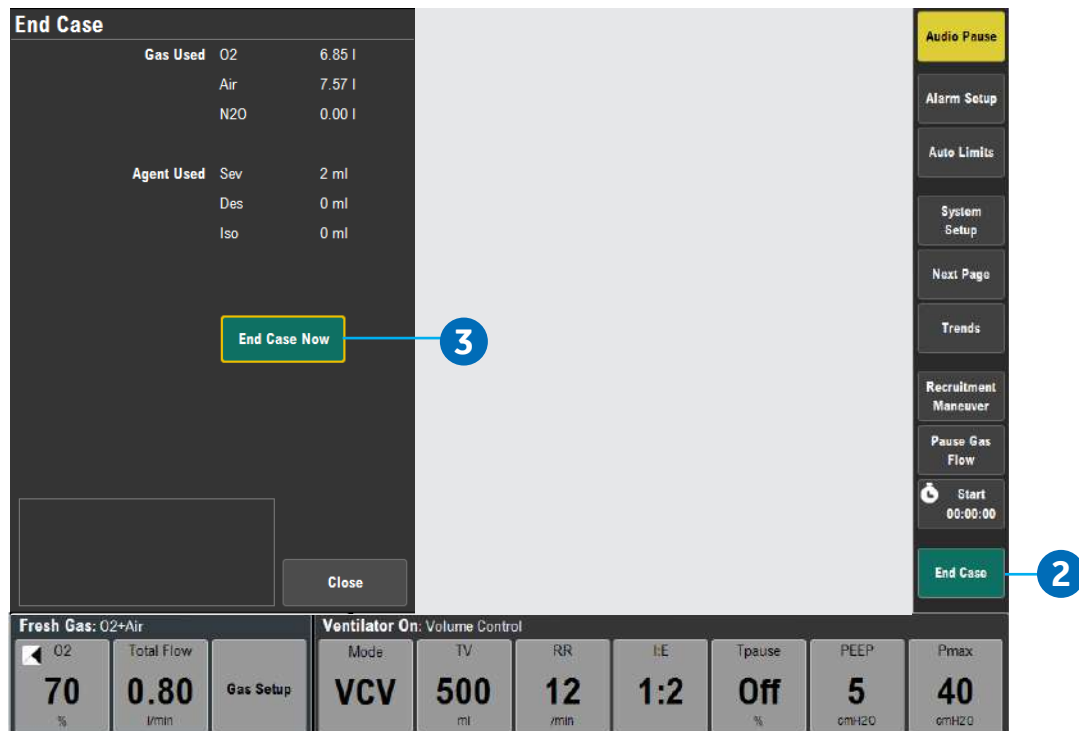

1. Set the Bag/Vent switch to Bag.
2. Select **End Case**.
3. Select **End Case Now** on the menu (the gas flow and patient alarms stop). The system is now in Standby. Select a quick key or the **Start Case** button to start a case.

Standby

When in Standby, most of the alarms are disabled. The Standby screen shows after **End Case** is selected.

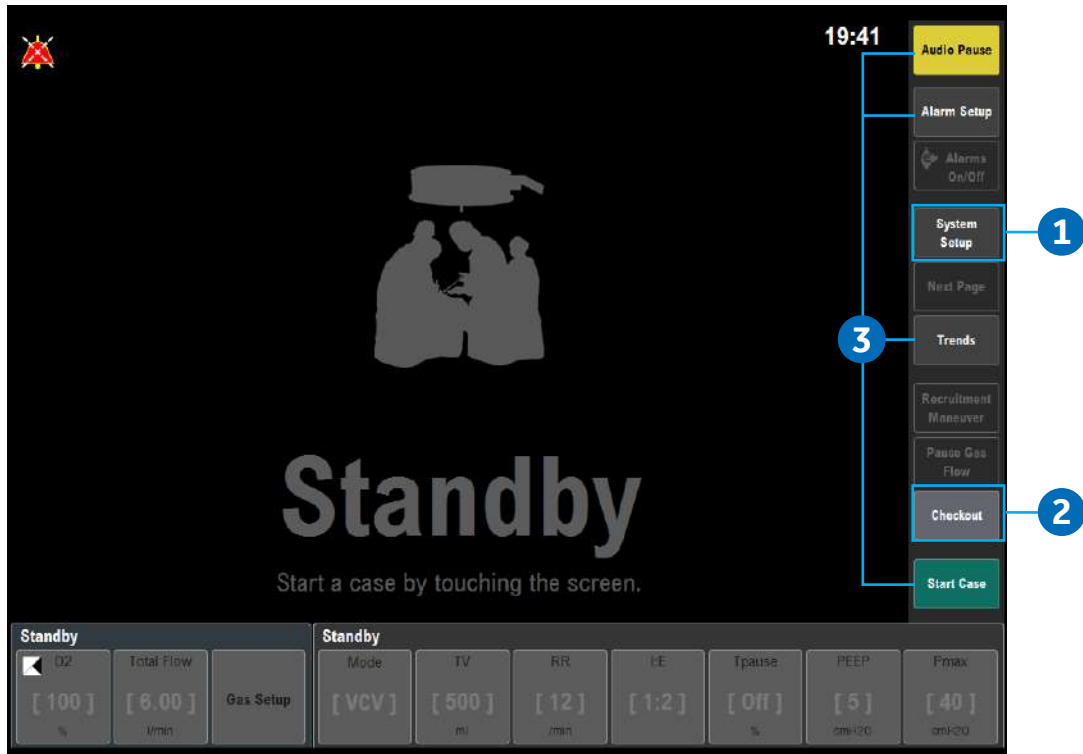

From the Standby menu:

1. Select **System Setup** to open the System Setup menu.
2. Select **Checkout** to open the Checkout menu.
3. Select any other active function key to open the Start Case menu.
4. A case can be started using the default settings by setting Bag/Vent switch to vent, turning on Aux O₂+Air switch, or by turning on ACGO switch.

Turning off the system

1. Perform the **End a case** procedure, if appropriate.
2. Push and hold the On/Standby switch for 1 second.
3. Select **Confirm** or push the ComWheel within 10 seconds to turn off the system.

If no action is performed within 10 seconds, the screen automatically returns to the previous display.

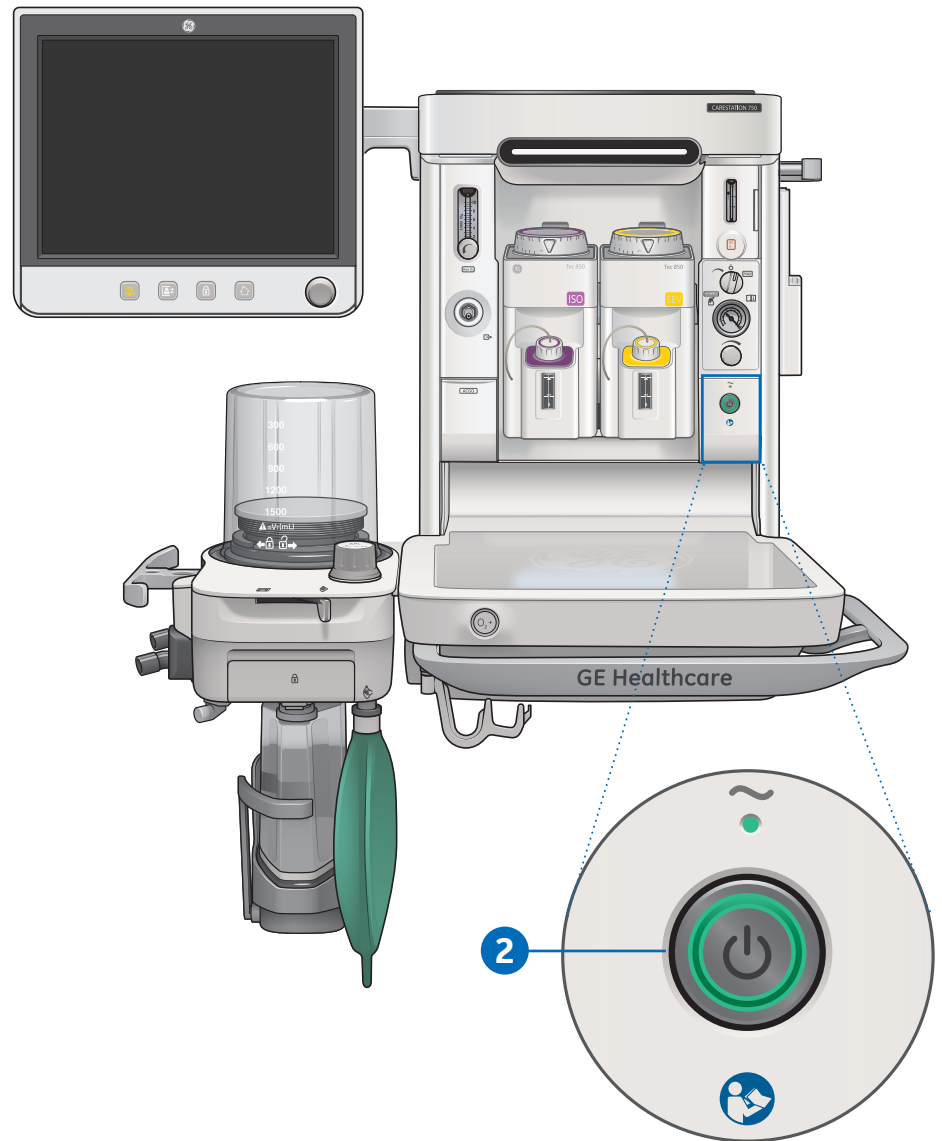



www.gehealthcare.com

GE Healthcare provides transformational medical technologies and services that are shaping a new age of patient care.

Our broad expertise in medical imaging and information technologies, medical diagnostics, patient monitoring systems, drug discovery, biopharmaceutical manufacturing technologies, performance improvement and performance solutions services help our customers to deliver better care to more people around the world at a lower cost.

In addition, we partner with healthcare leaders, striving to leverage the global policy change necessary to implement a successful shift to sustainable healthcare systems.

Carestation, CARESCAPE, D-fend, D-lite, PSVPro, Tec, and Selectatec are trademarks of General Electric Company or one of its subsidiaries.

All other brand names or product names used in this manual are trademarks or registered trademarks of their respective holders.

Product may not be available in all countries and regions. Full product technical specification is available upon request. Contact a GE Healthcare Representative for more information. Please visit www.gehealthcare.com

© 2020 General Electric Company – All rights reserved.

General Electric Company reserves the right to make changes in specifications and features shown herein, or discontinue the product described at any time without notice or obligation.

Notice: The materials contained in this document are intended for educational purposes only. This document does not establish specifications, operating procedures or maintenance methods for any of the products referenced. Always refer to the official written materials (labeling) provided with the product for specifications, operating procedures and maintenance requirements. Specifications are subject to change.

All patient names or other protected health information or data contained in any image within this material is fictitious. Any similarity to actual persons is coincidental.