

Manufacturer: Sanko Tekstil İşletmeleri Sanayi ve Ticaret A.Ş.
Type: Wheeled Loader

Technical Report

15-TAHP-EK-0086/SRH

According to ISO 3449 Earth-Moving Machinery Falling-Object Protective Structures

1 General

- 1.1 Make: Sanko
- 1.2 Type: MST Bachhoe Loader
- 1.3 Name and address of ROPS manufacturer: Sanko Tekstil İşletmeleri Sanayi ve Ticaret A.Ş.
4.Organize Sanayi Bölgesi
83414 Nolu Cad. No:124/1
TR-Şehitkamil / Gaziantep
- 1.4 Name(s) of address(es) of assembly plant(s): Sanko Tekstil İşletmeleri Sanayi ve Ticaret A.Ş.
4.Organize Sanayi Bölgesi
83414 Nolu Cad. No:124/1
TR-Şehitkamil / Gaziantep
- 1.5 Name and address of vehicle manufacturer: Sanko Tekstil İşletmeleri Sanayi ve Ticaret A.Ş.
4.Organize Sanayi Bölgesi
83414 Nolu Cad. No:124/1
TR-Şehitkamil / Gaziantep

Manufacturer: Sanko Tekstil İşletmeleri Sanayi ve Ticaret A.Ş.
Type: Wheeled Loader

Test Report

1. Trademark or name of protective structure

MST Backhoe Loader

2. Name and address of manufacturer of protective structure

Sanko Tekstil İşletmeleri Sanayi ve Ticaret A.Ş.
4.Organize Sanayi Bölgesi
83414 Nolu Cad. No:124/1
TR-Şehitkamil / Gaziantep

3. Name and address of machine manufacturer

Sanko Tekstil İşletmeleri Sanayi ve Ticaret A.Ş.
4.Organize Sanayi Bölgesi
83414 Nolu Cad. No:124/1
TR-Şehitkamil / Gaziantep

4. Specifications of machine on which the tests are carried out

4.1. Trademark

MST

4.2. Type and commercial description

MST Backhoe Loader

4.3. Serial number of ROPS

Not applicable

4.4. Mass of machine fitted with ROPS

9.240 kg

5.1. General arrangement drawing of both protective structure and its attachment to the machine

Refer to drawings.

5.2. Photographs from side and rear showing mounting details

Refer to enclosure.

5.3. Brief description of protective structure including type of construction, details of mounting on the tractor, details of cladding, means of access and escape, details of interior padding, features to prevent continuous rolling and details of heating and ventilation

Roof plate thickness is 4 mm, Bottom plate thickness is 3 mm, A pillar profile is 4,5 mm, B pillar profile is 4,5 mm, C pillar profile is 4,5 mm

Manufacturer: Sanko Tekstil İşletmeleri Sanayi ve Ticaret A.Ş.
Type: Wheeled Loader

The test was performed with ROPS and machine frame members soaked to 20 °C.
Verification of specification of the charpy V-notch impact strength requirements for ROPS structural metallic members:

Sample	Energy met at -20° C (J)	Energy met at -30° C (J)
6 mm S235JR quality sheet metal	154	160
4 mm shaped profile	68	76

5.4. Dimensions

Refer to drawings.

5.5. Details and quality of materials used, standard used

Refer to drawings

6. Identification of The Test Object

6.1 Performance level tested

Level II

6.2. Mass

297 kg

6.3. Falling Height

4,02 m

6.4. Dimensions of the test object



6.5. Picture of crashing point

See drawings

7. Test Results

7.1 Impact Test

Energy imparted to the test object without causing penetration of any part of the FOPS structure into the DLV nor penetration of the FOPS by the test object:

11712 J

Minimum performance requirements of TS EN ISO 3449 were met in this test.

Manufacturer: Sanko Tekstil İşletmeleri Sanayi ve Ticaret A.Ş.
Type: Wheeled Loader

8. Equipment for measuring and testing

Parameter of the test area 22 °C and %50 Humidity

9. Calibration Equipments

Test Instrument	Type	Manufacturer	ID - No.	
Loadcell	KHS125-200-AFB	MAG-BIAS	312011	<input checked="" type="checkbox"/>
Loadcell	20t	PULSE	HT1 20319	<input type="checkbox"/>
Loadcell	20t	PULSE	HT1 20318	<input type="checkbox"/>
Loadcell	HT1W	PULSE	3028H71	<input type="checkbox"/>
Loadcell	HT5M	PULSE	2910 HT1	<input type="checkbox"/>
Accelometer	--	--	5189683	<input type="checkbox"/>
Accelometer	--	Dytran	--	<input checked="" type="checkbox"/>
Accelometer	--	Dytran	--	<input checked="" type="checkbox"/>

10. Place and date of testing

BIAS Test Sistemleri
İkitelli Organize Sanayi Bölgesi
Metal İş Sanayi Sitesi 5.Blok No:57-59
34306 Başakşehir / İstanbul (TURKEY) 03.09.2014

11. Final Confirmation

As the result of inspections of Sanko Tekstil İşletmeleri Sanayi ve Ticaret A.Ş. company's sample seat, it has been confirmed that the sample vehicle fulfilled the requirements related to the TS EN ISO 3449 as given.

This report can not be multiplied without written approval of TÜV AUSTRIA.

This technical report consists of 4 pages.

Istanbul

26.05.2015

Recognized Expert
Eren AKDAĞ

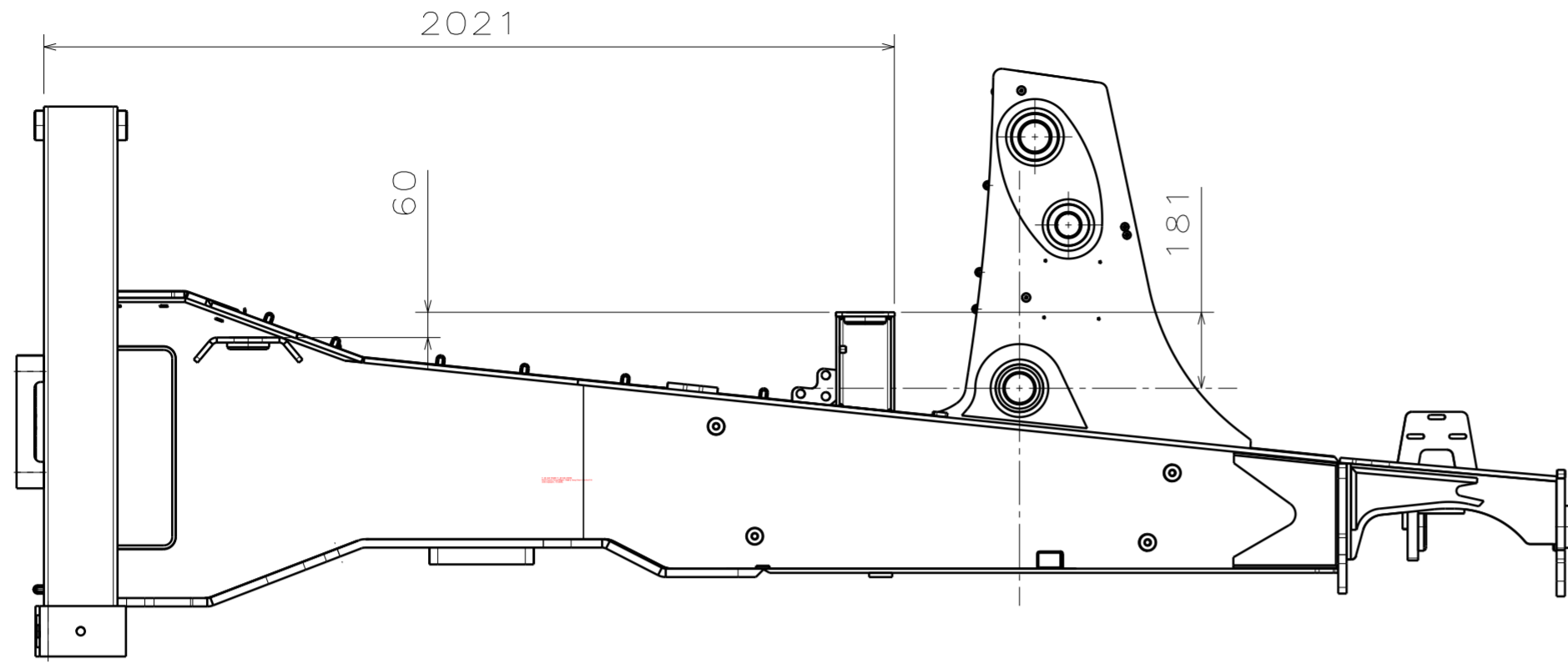

Front view
Scale: 1:15

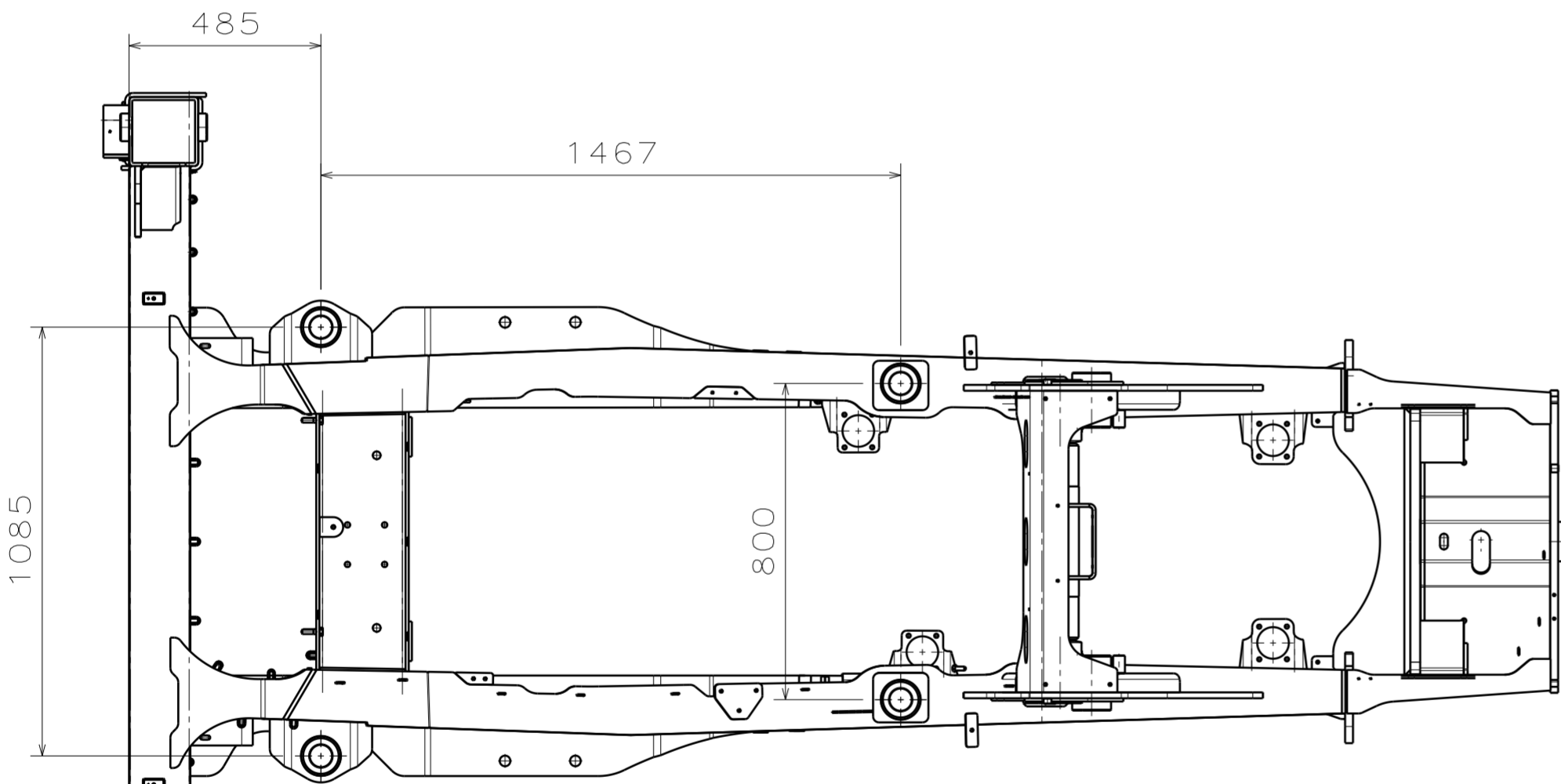

Top view
Scale: 1:15

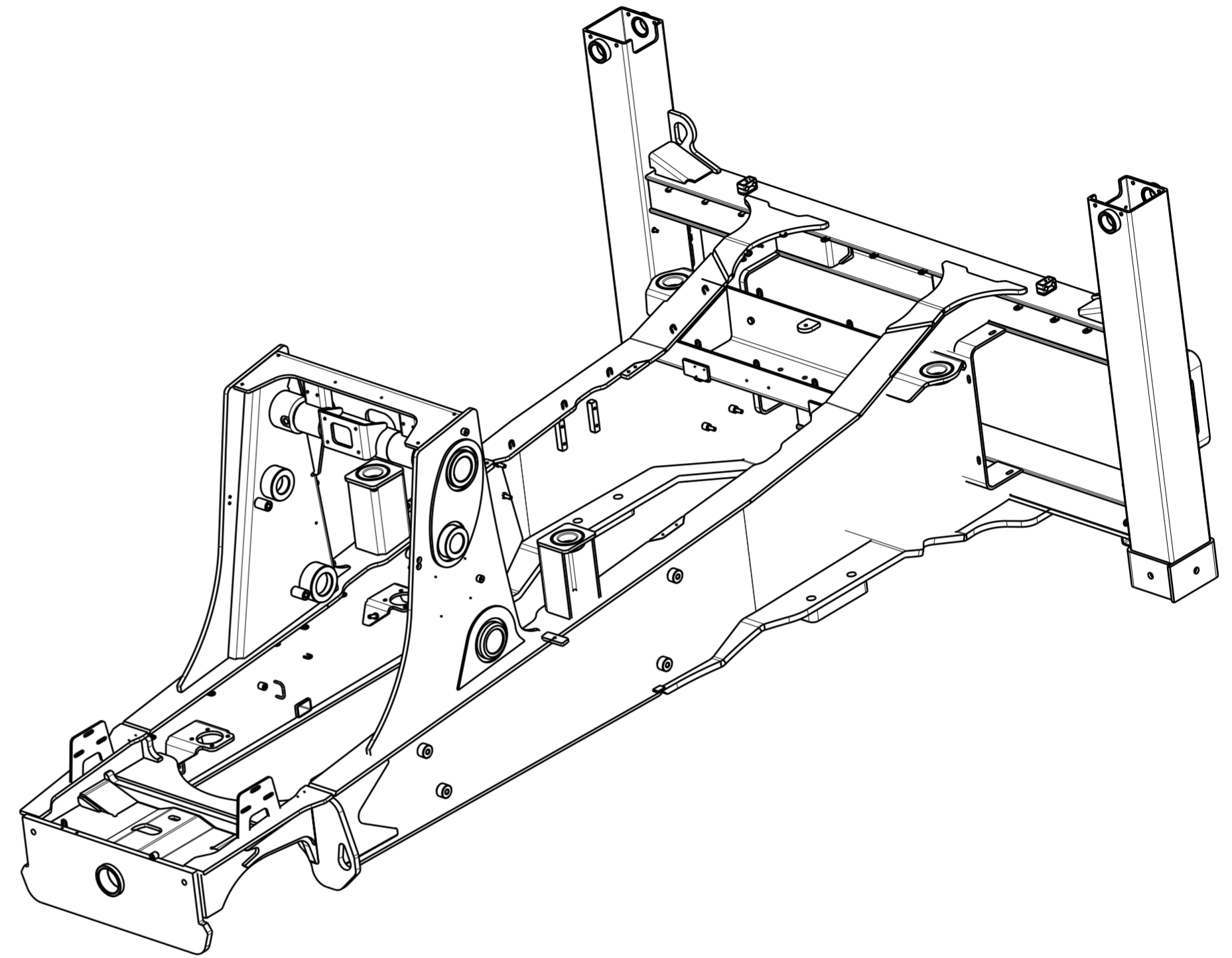

Isometric view
Scale: 1:15

DESIGNED BY: S.MEMIKBESE	DATE: 27.05.2015	CHECKED BY: M.SONMEZ	APPROVED BY: L.KIRILANGIC	UR-GE DEPARTMAN I
TOTAL EFFECTIVE CASE DEPTH		SCALE 1:15	Weight (Kg) 1.051,14	
HARDNESS		HOMOLOGATION	QUANTITY	UOONU ACI METODU OLOULER mm DIR THIRD ANGLE METHOD DIMENSIONS IN mm
CORE	SURF.		MATERIAL St 52-3:	
HEAT TREATMENT		UNSPECIFIED TOLERANCES		DRAWING NAME MST 644 PLUS SASE
FINISH		DIN EN 10025-94		DRAWING NUMBER 174631003
				SIZE A2

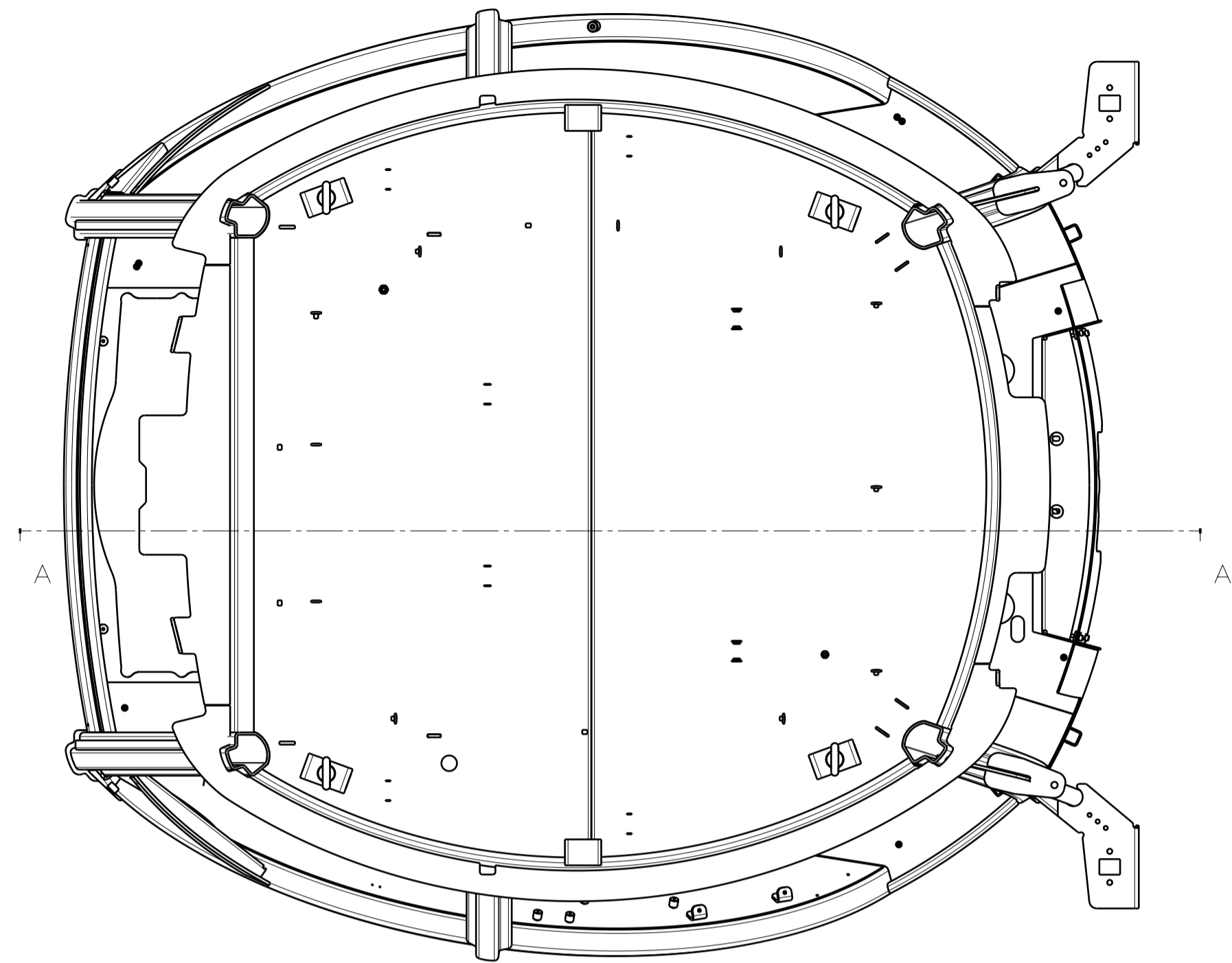

Front view
Scale: 1:10

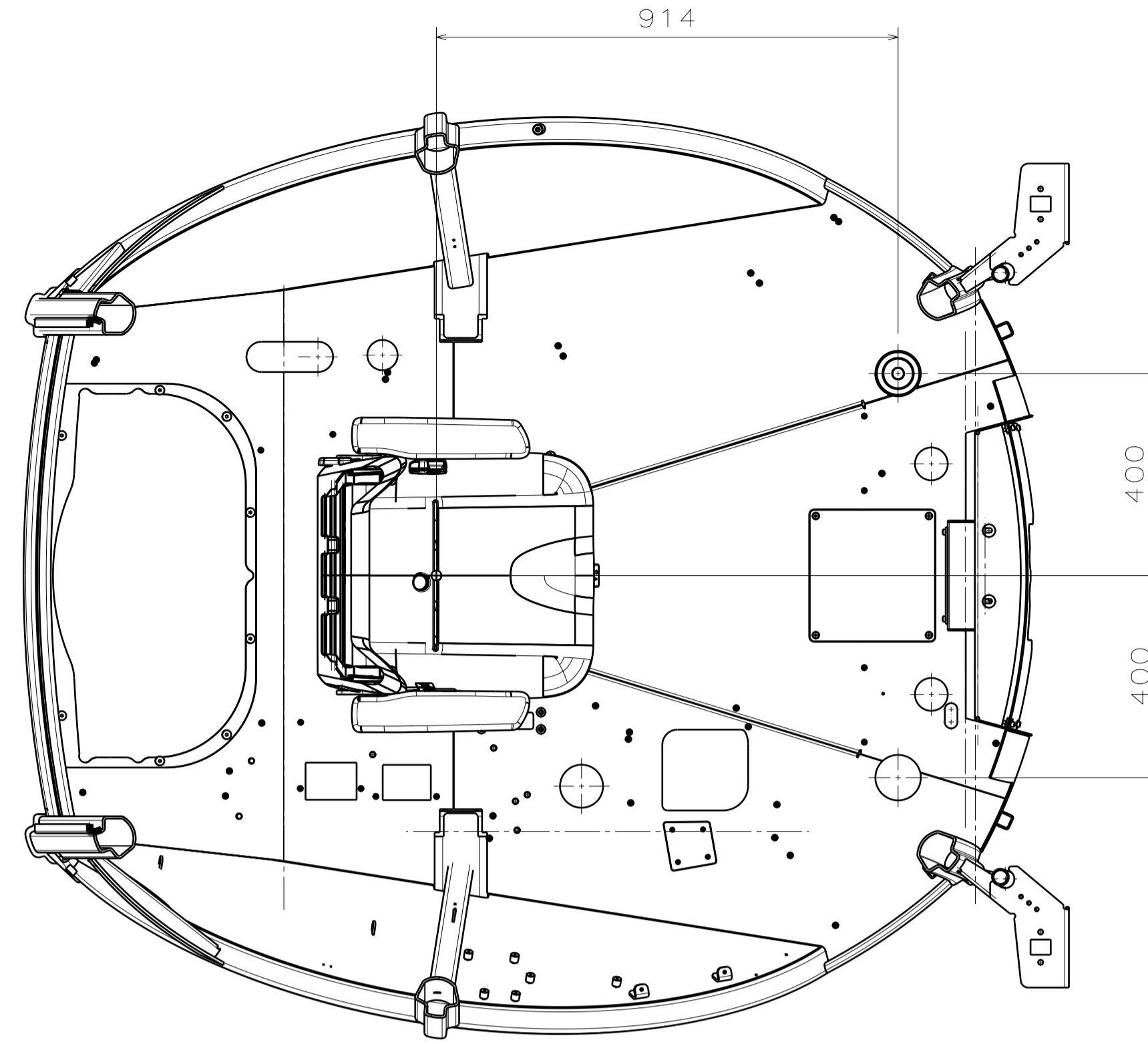

Section view B-B
Scale: 1:10

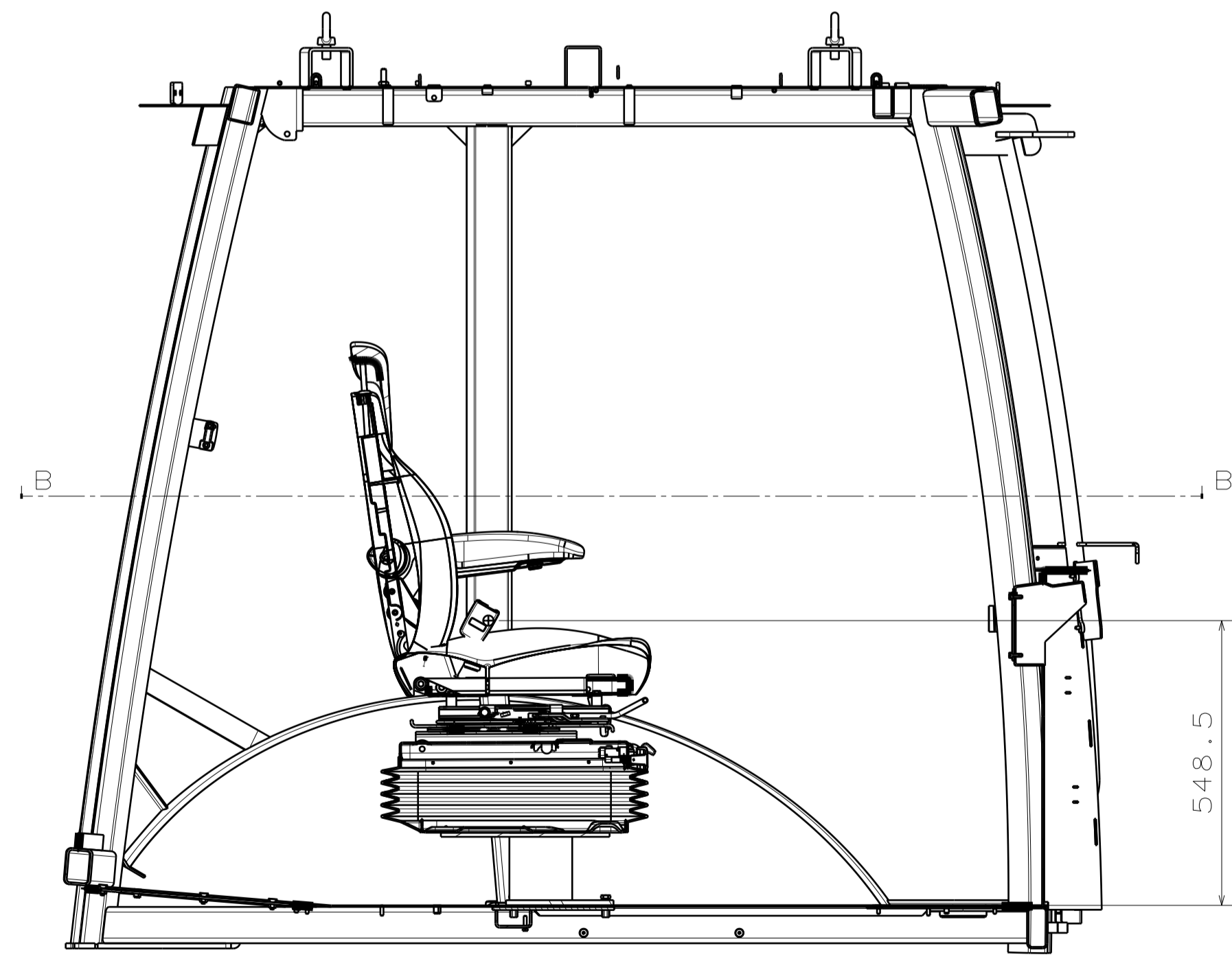

Section view A-A
Scale: 1:10

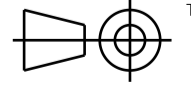
DESIGNED BY: S. KEMPERBERG	DATE: 27.05.2015	CHECKED BY: M. SCHNEZ	APPROVED BY: L. KREIBERGER	UR-GE DEPARTMENT
TOTAL EFFECTIVE CASE DEPTH	SCALE: 1:10	WEIGHT (kg): 1.994,01	QUANTITY	
HARDNESS	HOLOCLOCATION	MATERIAL: St 52-3	UNSPECIFIED TOLERANCES	UJUNCU AÇI METODU ÇÖKÜLER mm DİR REFERENCE MST 6 PLUS KABIN A1
CORE	SURF.	HEAT TREATMENT	FINISH	
DIN EN 10025-94			DRAWING NUMBER: 172770020	THIRD ANGLE METHOD  DIMENSIONS IN mm A1 A1

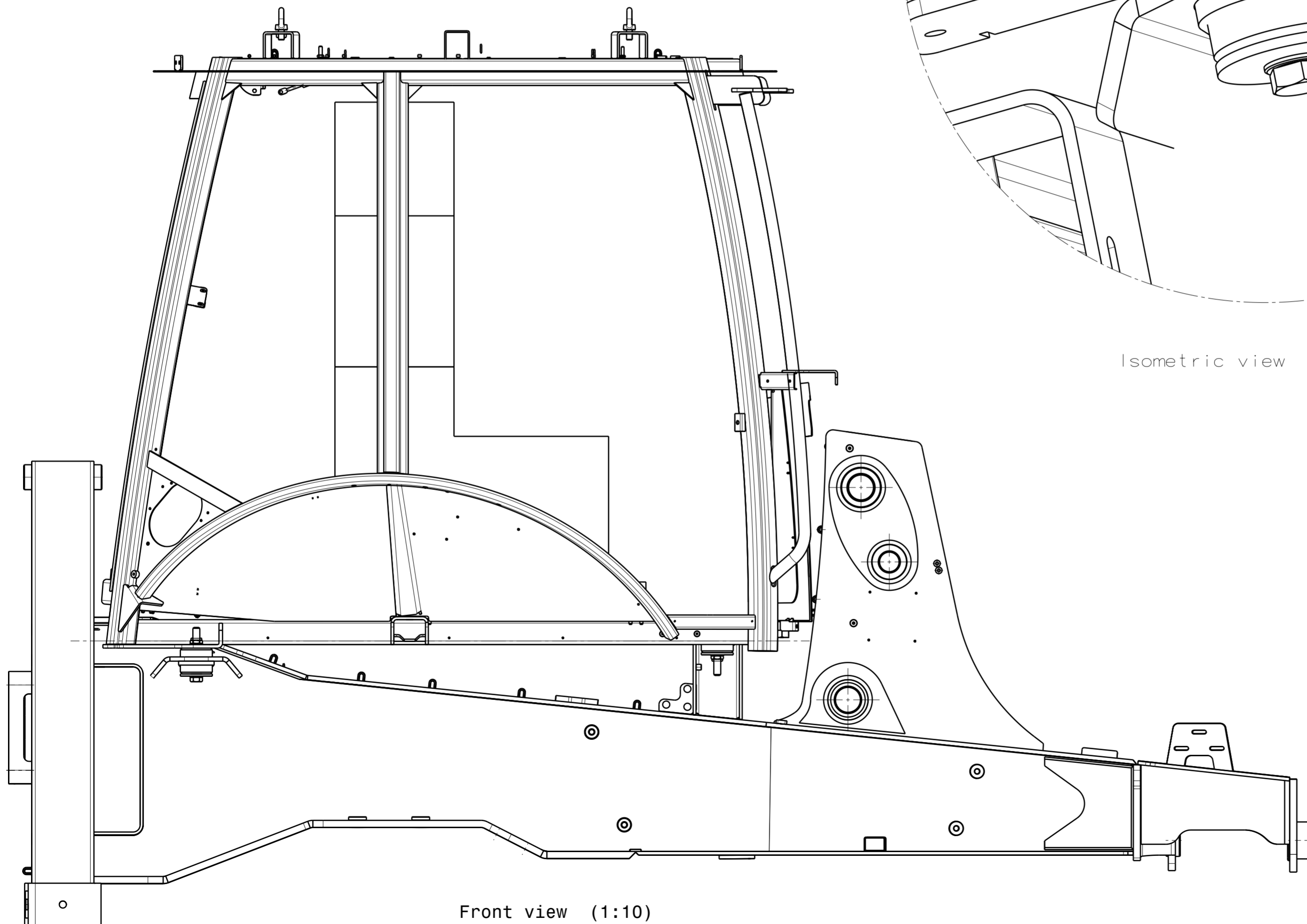

Front view (1:10)

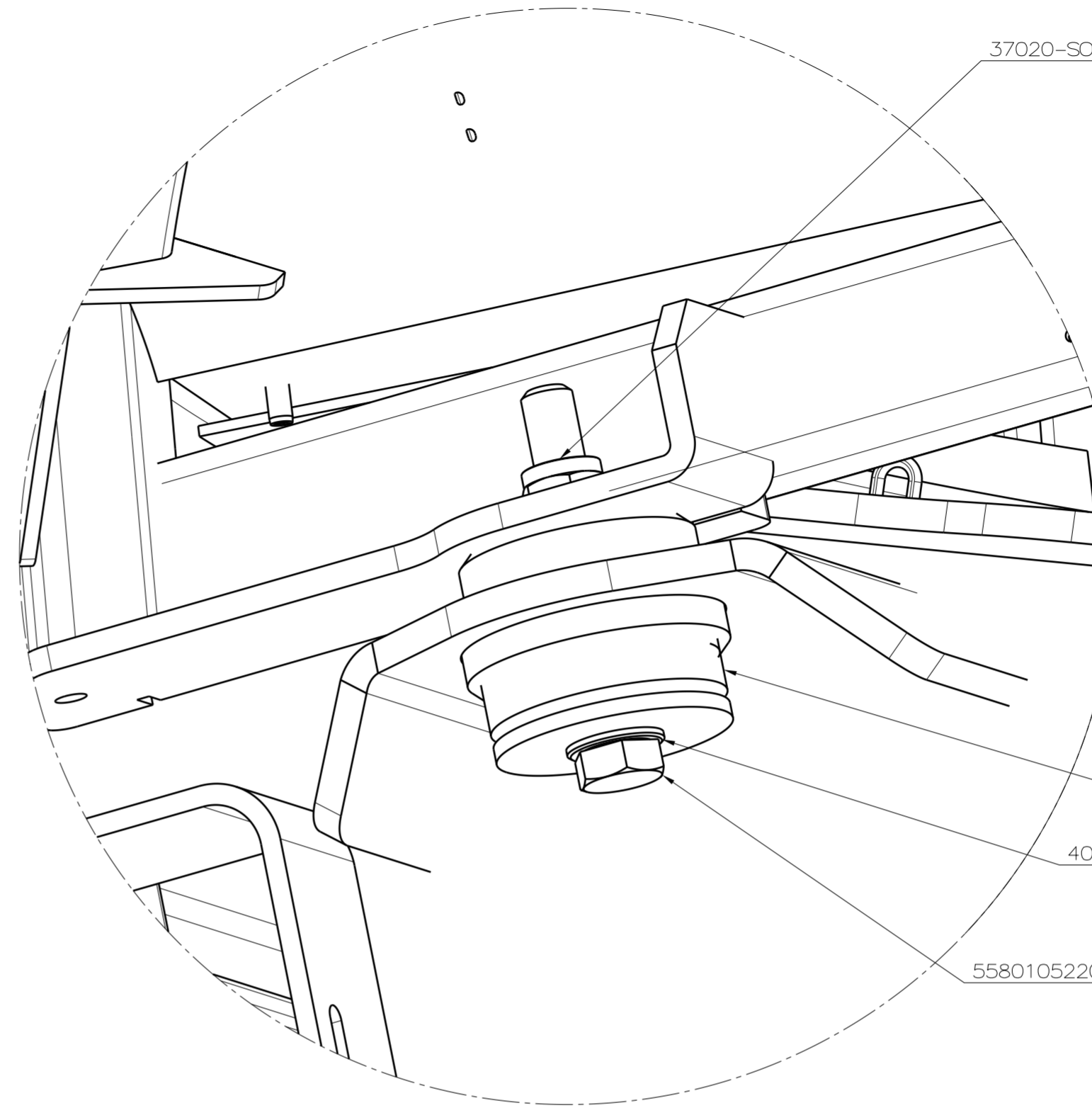

Isometric view (1:2)

37020-SOMUN, DIN 985, 10, M20, GVZ (AKB Fiberli)

174770272-KABIN TAKOZU

40520-RONDELA, DIN 125, M20, SIYAH

5580105220140000-CIVATA, DIN 931, 10.9, M20x140, GVZ

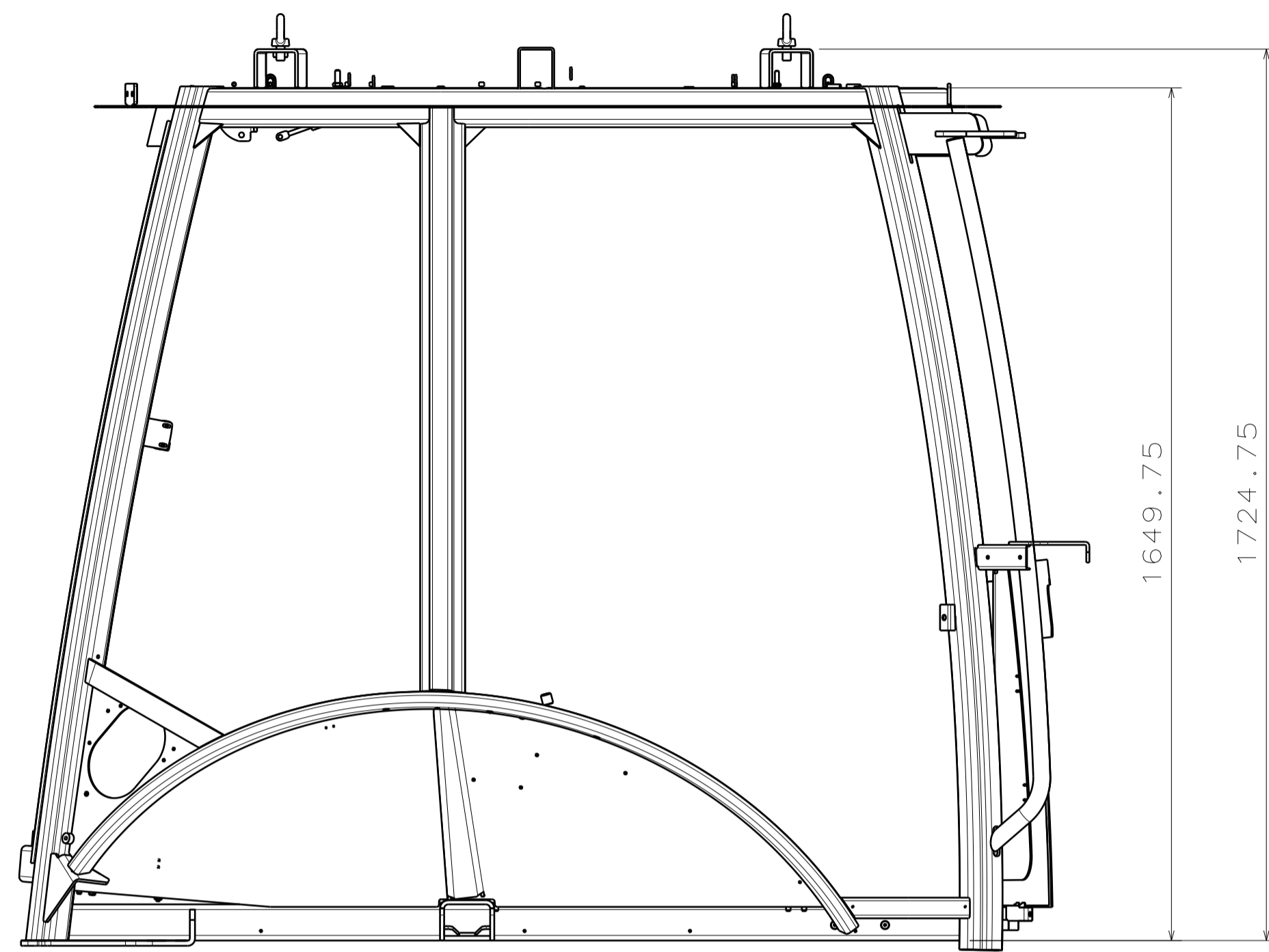

Front view
Scale: 1:10

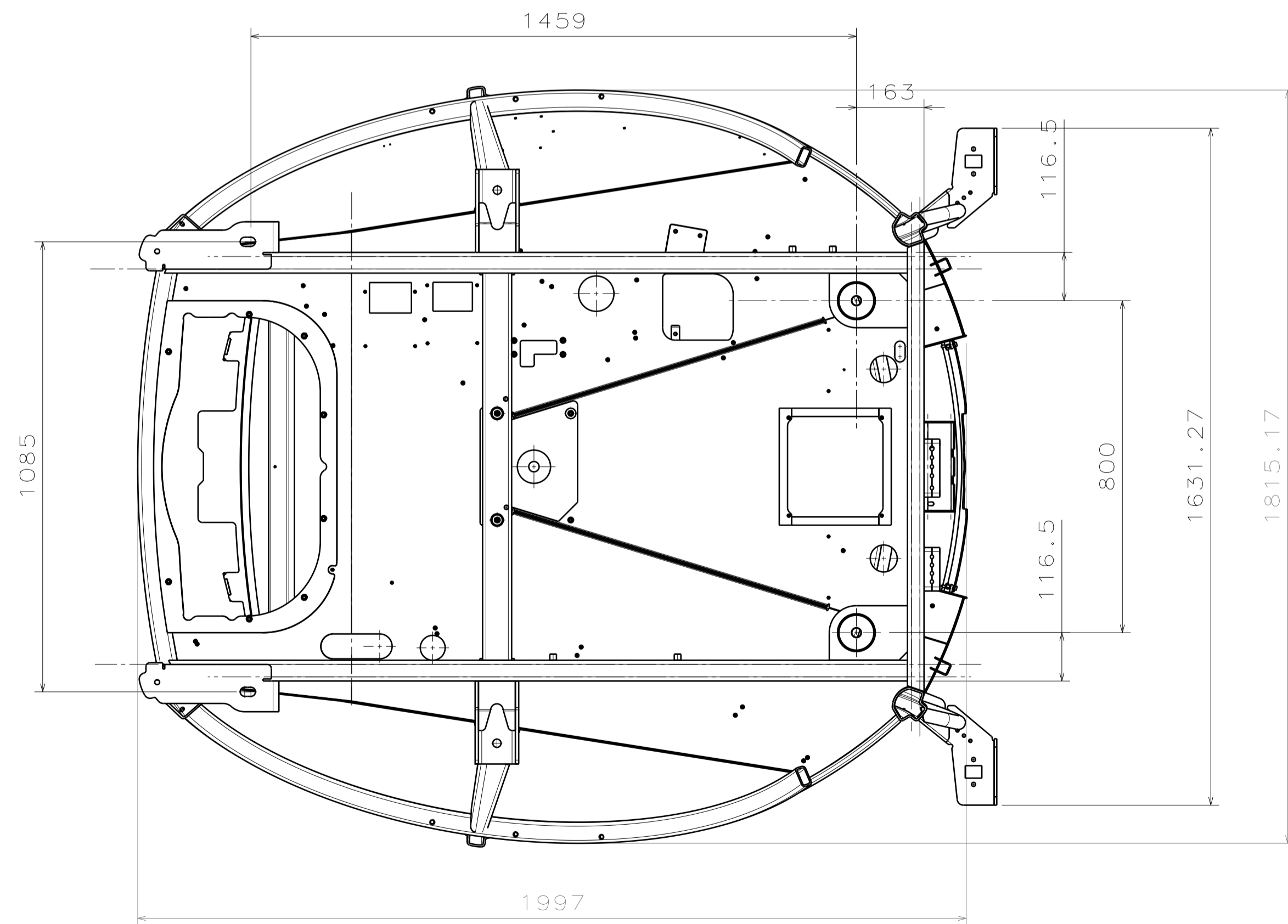

Bottom view
Scale: 1:10

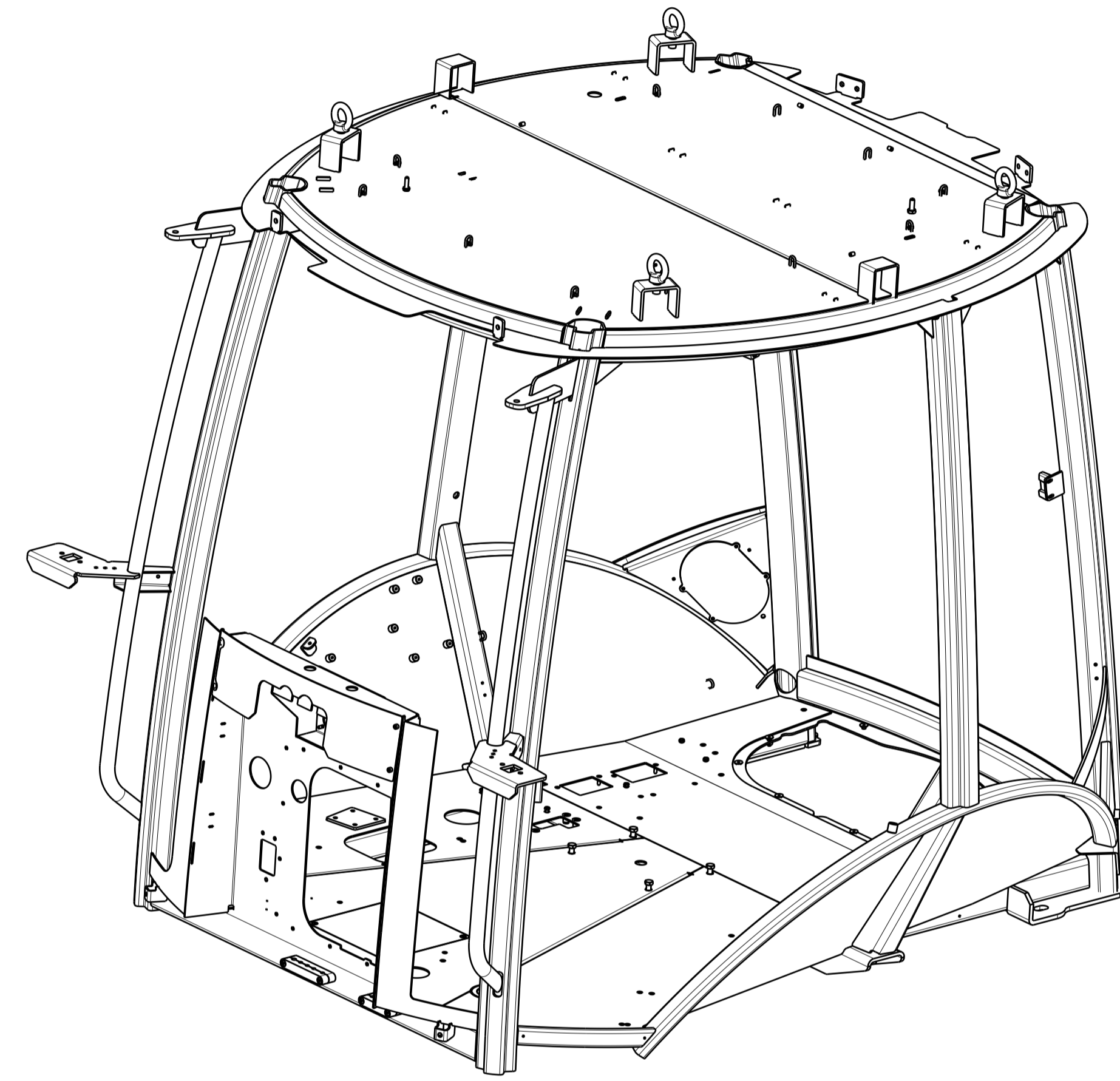

Isometric view
Scale: 1:10

DESIGNED BY: SANKOBISE	DATE: 27.05.2015	CHECKED BY: M.SOMIZ	APPROVED BY: L.KITRANJIC	UR-GE DEPARTMANI
TOTAL EFFECTIVE CASE DEPTH	SCALE: 1:10	WEIGHT (kg): 1.994_01	QUANTITY	
HARDNESS	HOLOGRACION	MATERIAL: St 52-3	UNSPECIFIED TOLERANCES	 THIRD ANGLE METHOD DIMENSIONS IN mm
CORE SURF.	HEAT TREATMENT	FINISH	DIN EN 10025-94	
DRAWING NAME: MST 6 PLUS KABIN			SIZE: A1	DRAWING NUMBER: 172770020
DRAWING NUMBER: 172770020			SIZE: A1	

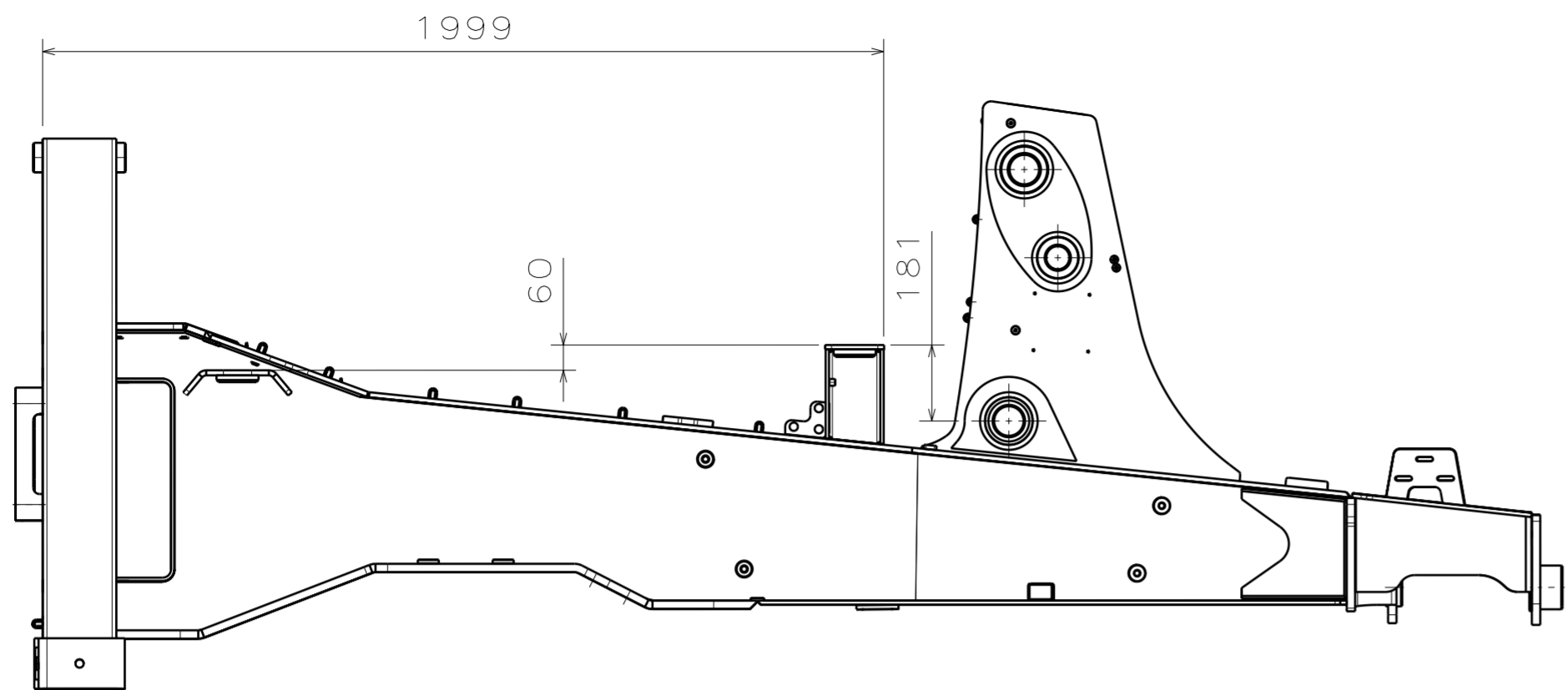

Front view
Scale: 1:15

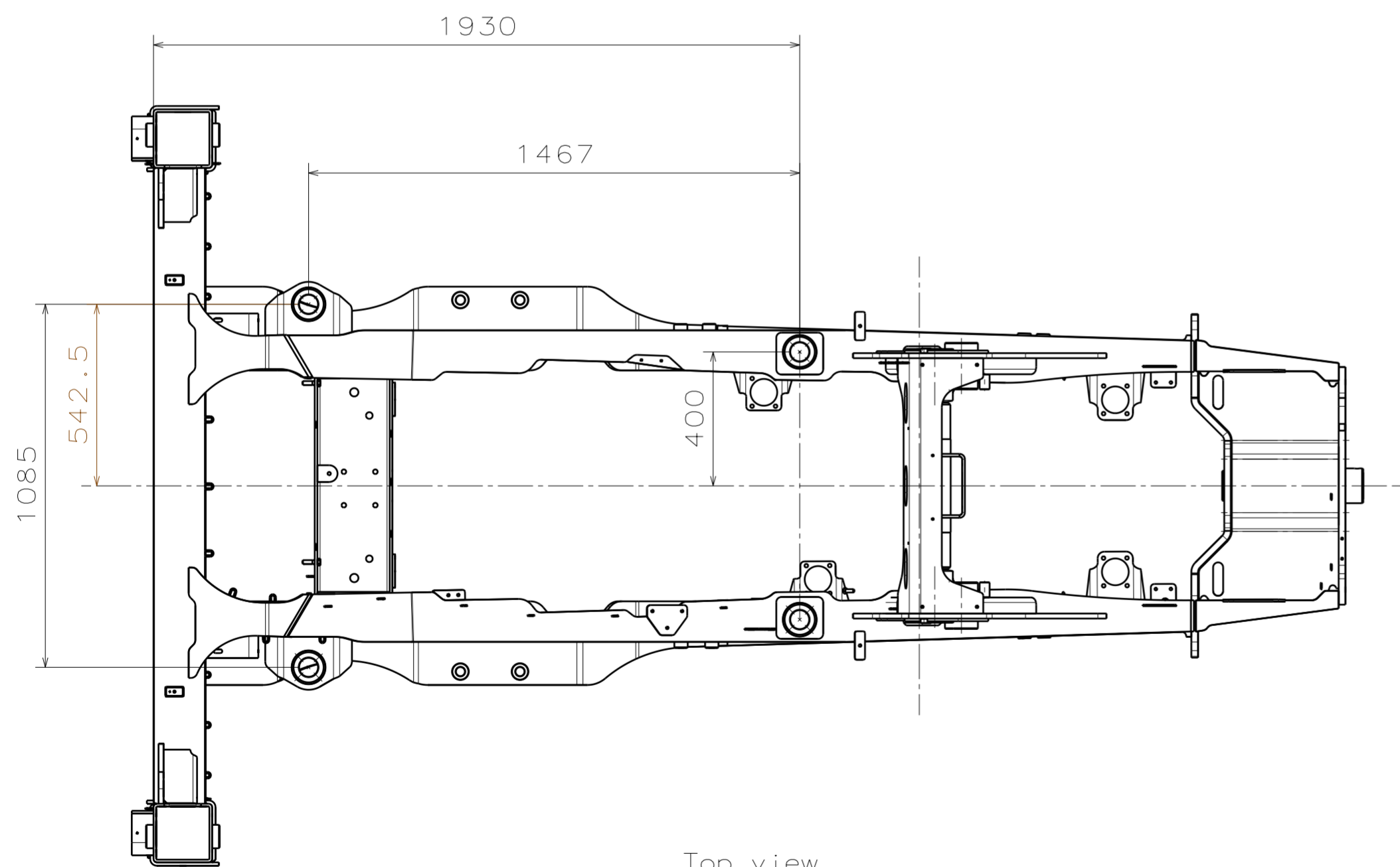

Top view
Scale: 1:15

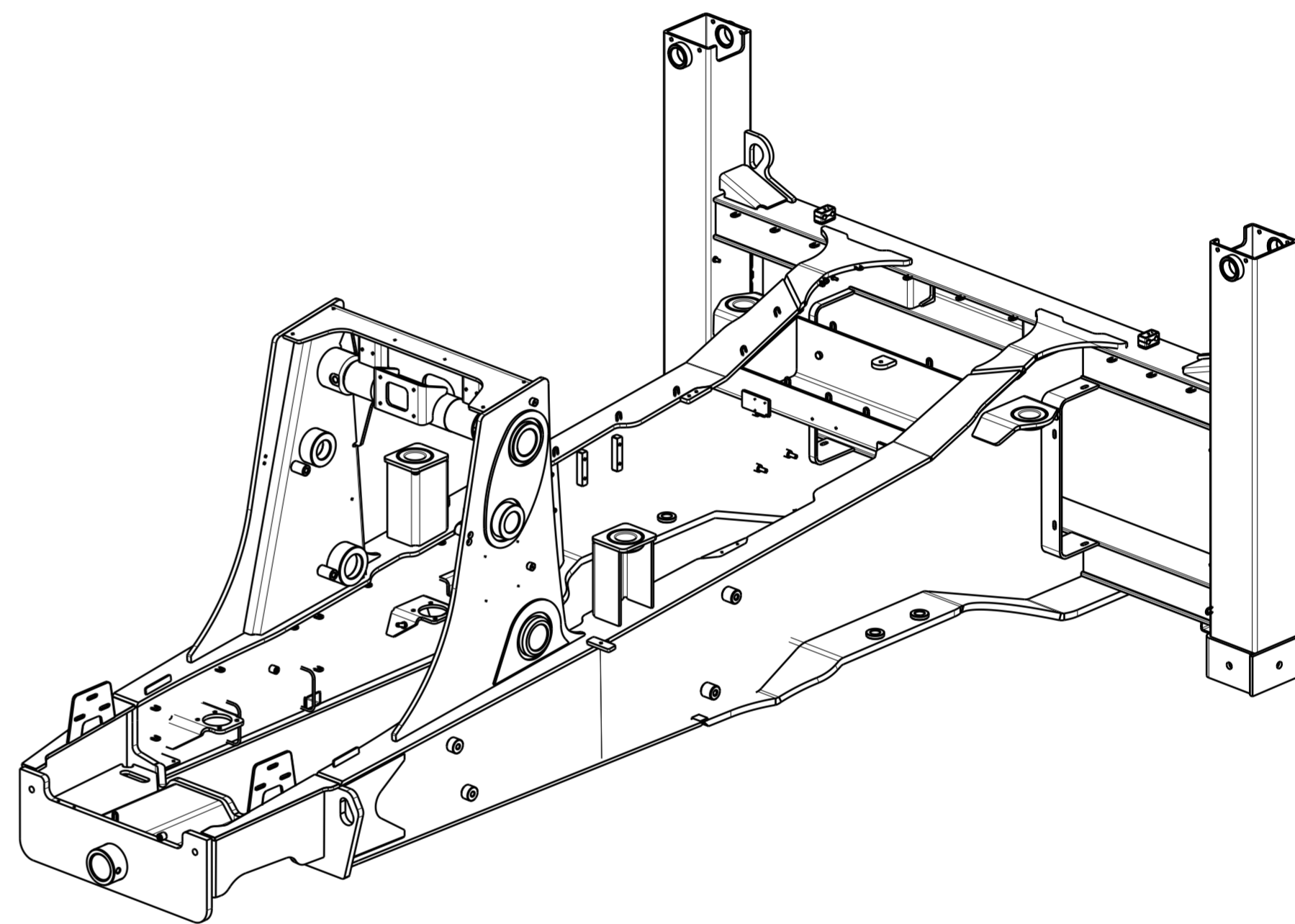

Isometric view
Scale: 1:15

DESIGNED BY: S. MEMIKBESE	DATE: 27.05.2015	CHECKED BY: M. SONMEZ	APPROVED BY: L. KIRILANGIC	UR-GE DEPARTMAN I
TOTAL EFFECTIVE CASE DEPTH	SCALE: 1:15	WEIGHT (Kg): 1.132,79	QUANTITY	
HARDNESS	HOMOLOGATION	MATERIAL	LOUNOU ACI METODU	THIRD ANGLE METHOD DIMENSIONS IN mm
CORE SURF.	WELDING ASSY	REFERENCE	QLOCLER mm DIR	
HEAT TREATMENT	UNSPECIFIED TOLERANCES	DRAWING NAME: MST6 2 WS PLUS SASI	A2	
FINISH	DIN EN 10025-94	DRAWING NUMBER: 172631003	A2	

REV. NO Rev. Nr.	TARİH Date	HARF Letter	DEĞ.TALEP NO Rev.Reguest Nr.	DEĞİŞİKLİK Modifications	İSİM Name	İMZA Signature
00	26.04.2013	-----	-----	YENİ YAYINLANMIŞTIR. New Released		

STATİK TEST GRAFİĞİ STATIC TEST CURVE

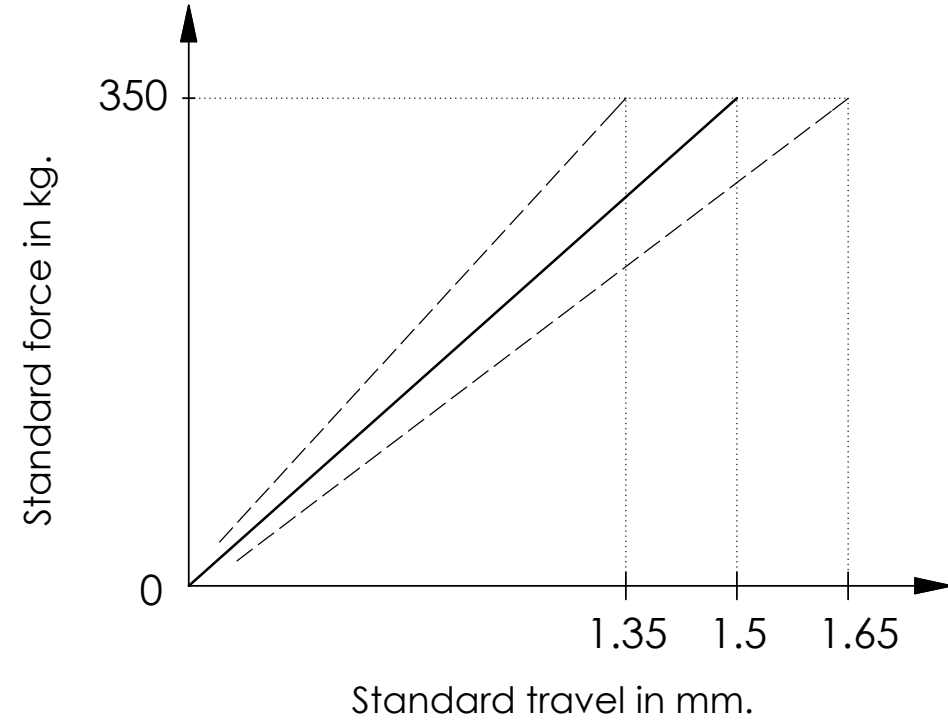

İZOMETRİK GÖRÜNÜŞ ISOMETRIC APPEARANCE

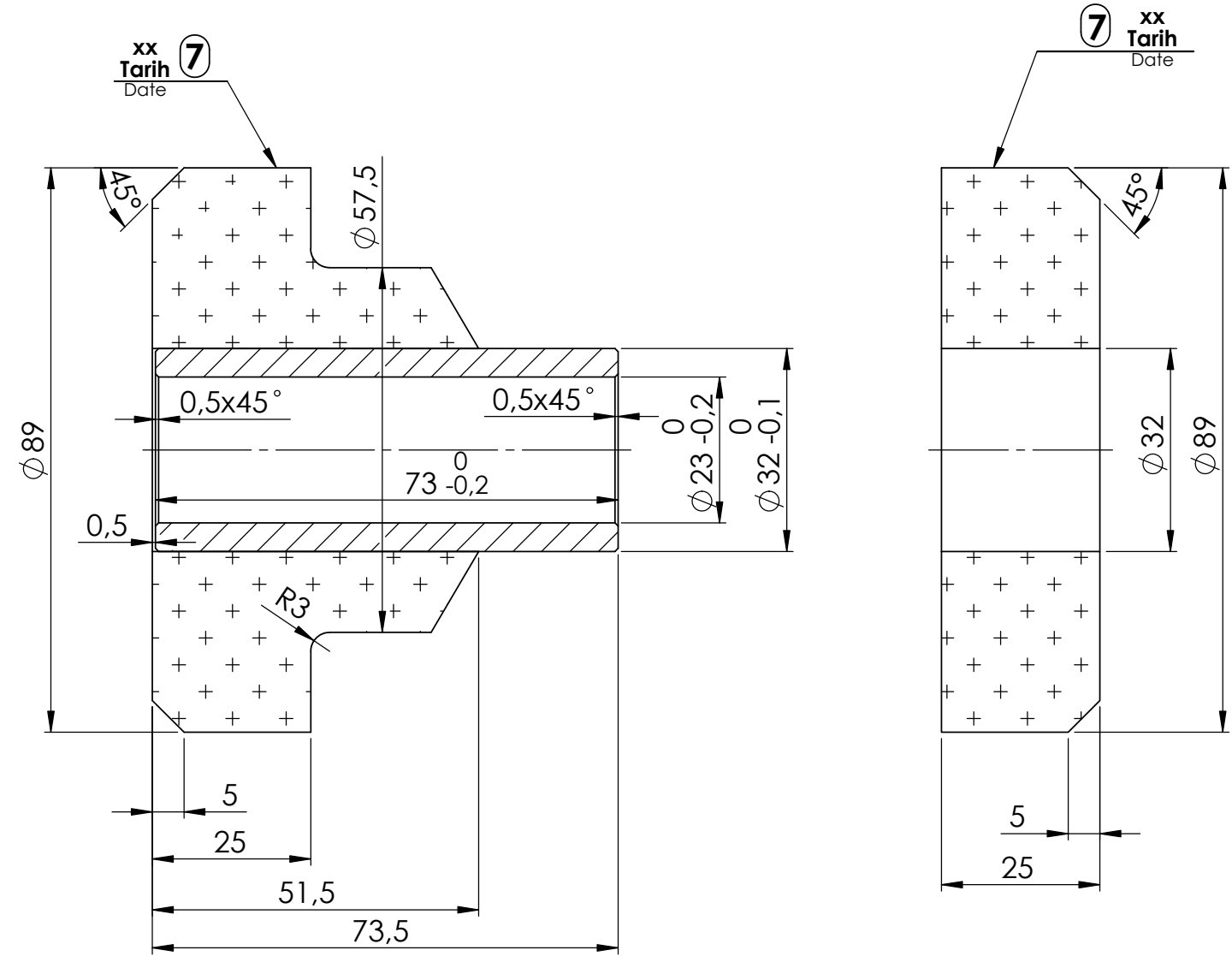
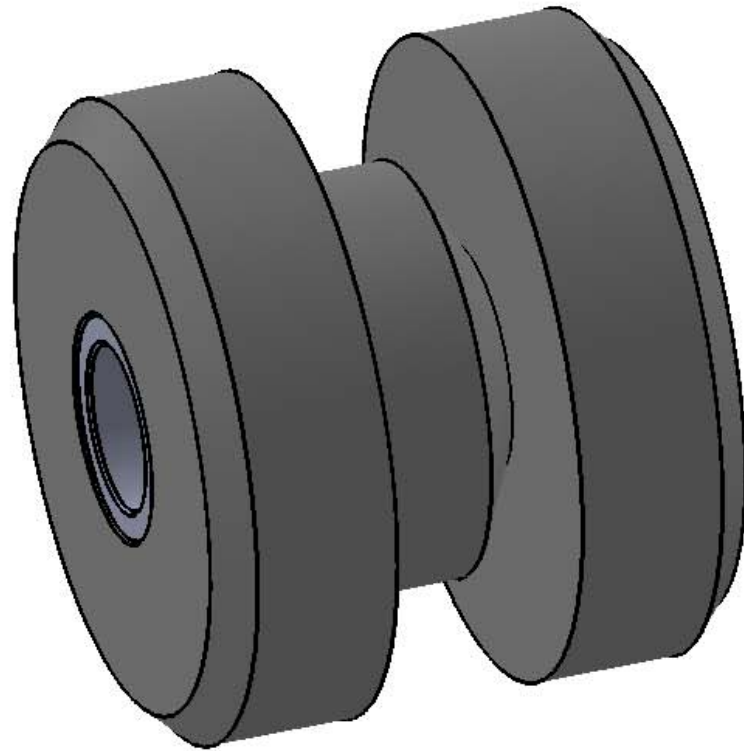

İÇ BORU YÜZEY KORUMA : Zn (Cr+3) SARI KAPLAMA
INNER PIPE SURFACE PROTECTION : Zn (Cr+3) YELLOW COATED
(B): 13-60 Sertlik NR 60±3 Shore A
13-60 Hardness NR 60±3 Shore A
(A): EN 10305-2 E 235+C

SIRA Sequence	PARÇANIN ADI Part Name	MALZEME Material	ADET Quantity	MONTAJ NO Assembly Nr.	MALZEME Material	RESİM NO Drawing Nr.	AĞIRLIK Weight
3	YAN LASTİK RUBBER	RUBBER	1	3	(B)	1236/2	
2	LASTİK HAMURU RUBBER COMPOUND	RUBBER COMPOUND	1	2	(B)	1236/1B	
1	İÇ BORU INNER PIPE	INNER PIPE	1	1	(A)	1236/1A	
SIRA Sequence		SEM NO Sem Nr.	ÇİZEN Drawn by	TARİH Date	İMZA Signature		
Desing : Design		1236	HÜLYA KONAK	26.04.2013			
Solidworks		REFERANS NO Reference Nr.	KONTROL Controlled by	TARİH Date	İMZA Signature		
			SERKAN GÖMEÇ	26.04.2013			
Format : A3		MALZEME Material	ONAY Approved by	TARİH Date	İMZA Signature		
			AYHAN TOKAY	26.04.2013			
		RESİM NO Drawing Nr.	ÖLÇEK Scale	PARÇA ADI Part Name			
		1236	1:1	KABİN TAKOZU CABIN MOUNTING			

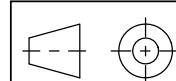

RESİMDE VERİLMEDİĞİ TAKTİRDE
IF NOT GIVEN IN THE DRAWING
UYGULANACAK OLAN TOLERANS NORMU
TOLERANCE FROM TO BE USED

DIN ISO 2768 mK
DIN ISO 3302-1M3

İS BU DÖKÜMANIN KULLANMA ve UYGULANMASI İLE İLGİLİ HER TÜRLÜ HAKLARI SEM LASTİK SAN.TİC.A.Ş.'NE AİTTİR.İZİNSİZ KOPYA EDİLEMEZ.ÜÇÜNCÜ SAHİSLAR TARAFINDAN BASKA MAKSATLA KULLANDIRILAMAZ.
ALL RIGHTS RELATING TO USE AND APPLICATION OF THIS DOCUMENT BELONGS TO SEM LASTİK SAN.TİC.A.Ş. IT CAN NOT BE ALLOWED USING OF BY THIRD PEOPLE.IT CAN NOT BE COPIED WITHOUT OUR WRITTEN PERMISSION.

SEM
**SEM LASTİK
SAN.TİC.A.Ş.**
Yeni Yalova Yolu
13.Km. Ovaakça
BURSA / TÜRKİYE
Tel:(0224) 267 05 41

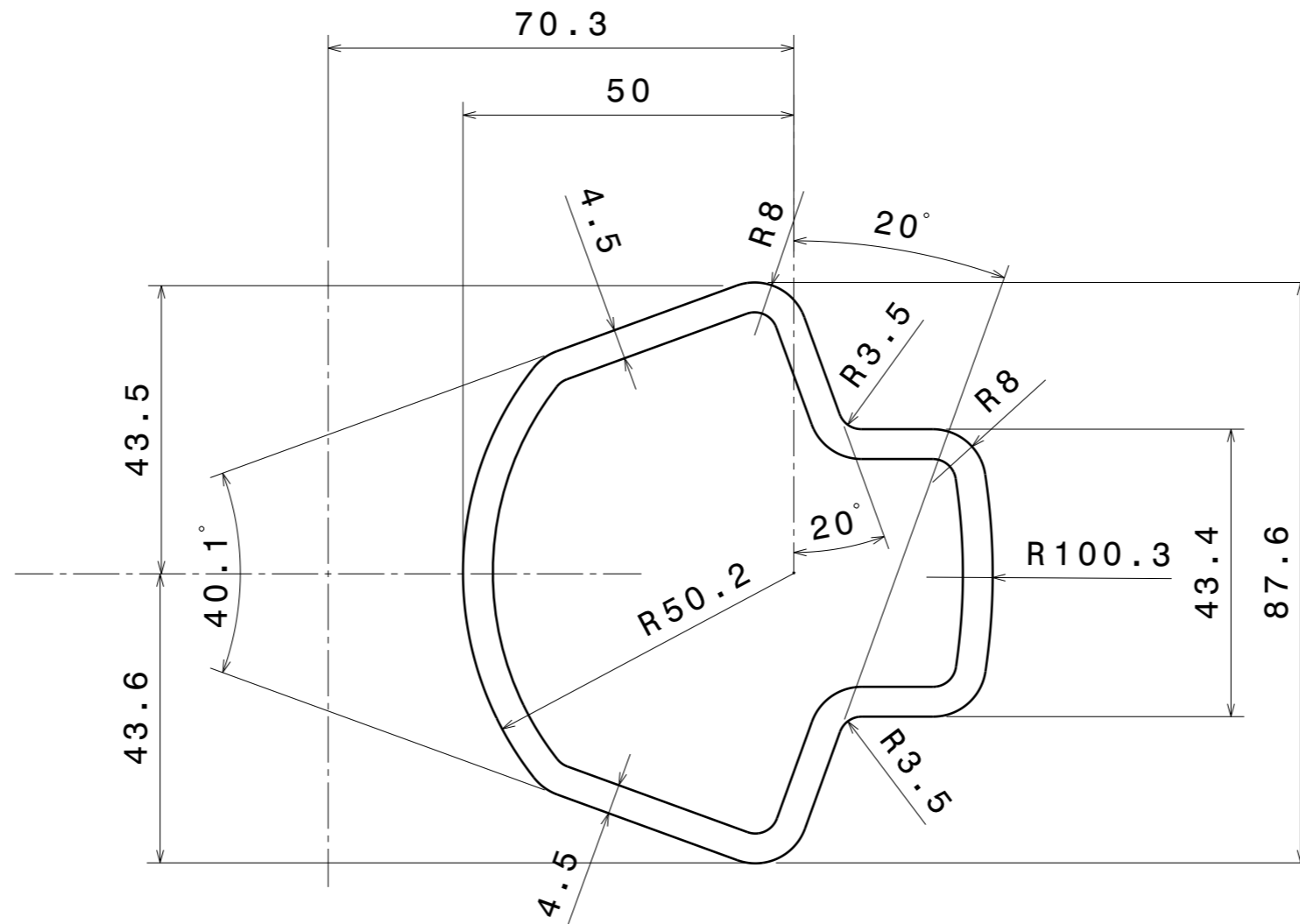

Front view
 Scale: 1:1

1 2 3 4 5 6 7 8

REV	DEĞİŞİKLİK	TARİH	İSİM	ONAY
1	172770025,172770029 ve 172770030 komplelerine revizyon işlenmiştir.	14.08.2014	E.DOĞAN	A.TOGAY
2	172770029 kompleksine revizyon işlenmiştir.172770195 numaralı parçanın tasarımını değiştirdiği için ilgili ölçüler değişmiştir.	08.10.2014	E.DOĞAN	A.TOGAY
3	172770025,172770029,172770030,172770026 komplelerine revizyon işlenmiştir.	11.06.2015	E.DOĞAN	A.TOGAY

A
B
C
D
E
F

A
B
C
D
E
F

SANKO
MST 6

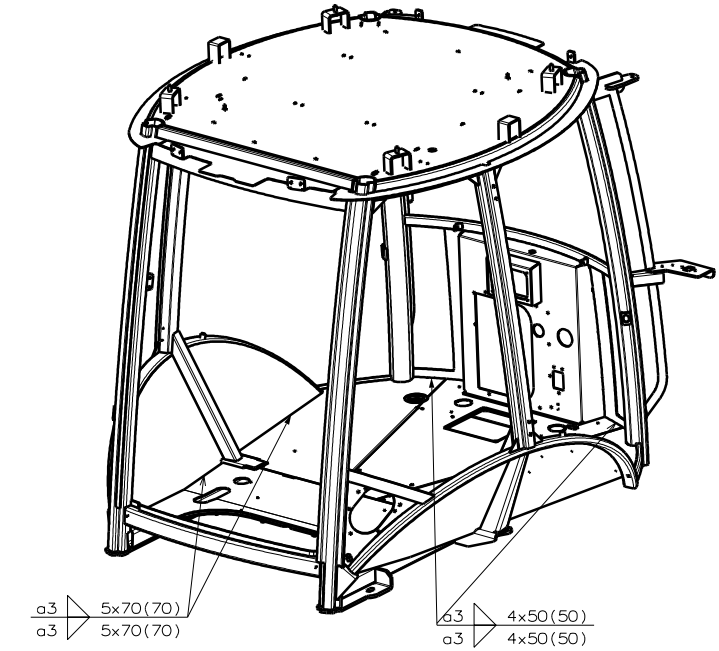
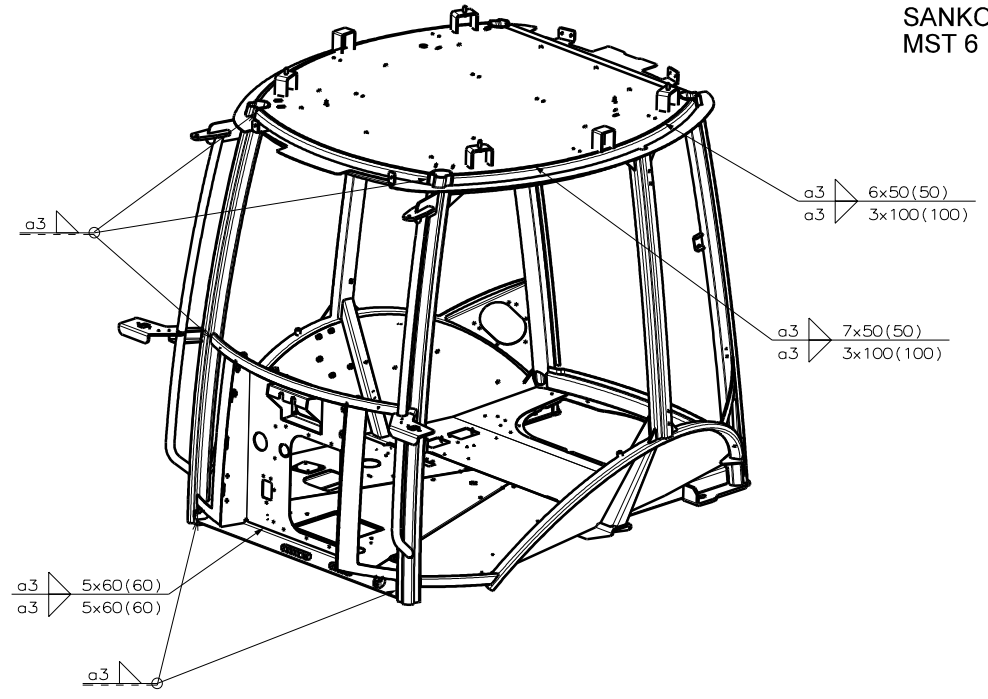
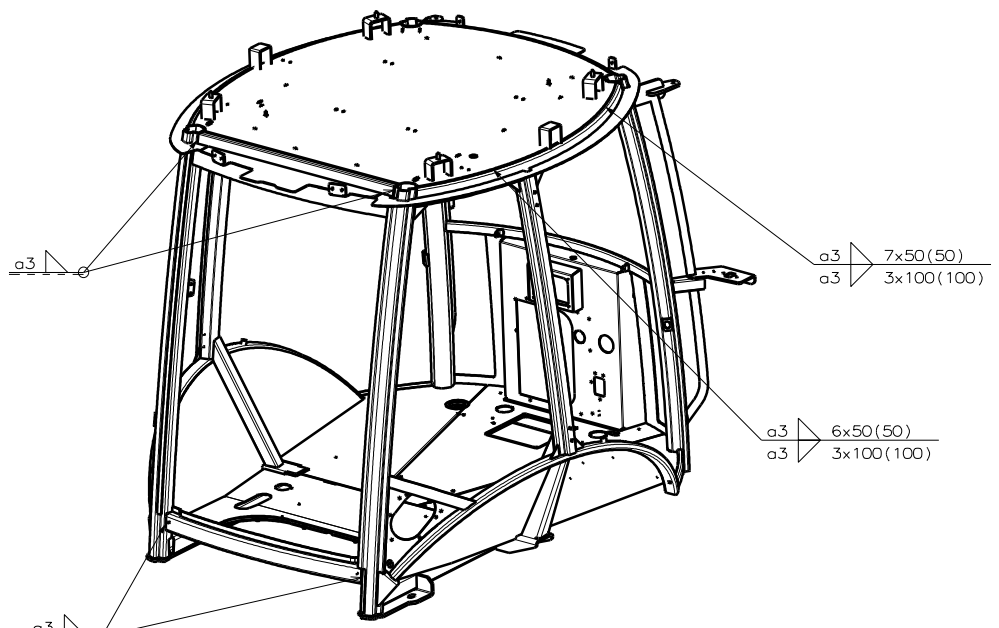

Bill of Material: 172770027

Number	Nomenclature	Quantity	Part Number	Type	Revision
1	TAVAN KAYNAKLI KOMPLESİ	1	172770025	Assembly	
2	SOL YAN KAYNAKLI KOMPLE	1	172770030	Assembly	
3	SAG YAN KAYNAKLI KOMPLE	1	172770029	Assembly	
4	TABAN KAYNAKLI KOMPLESİ	1	172770026	Assembly	
5	ON GÖĞÜS KAYNAKLI KOMPLESİ	1	172770028	Assembly	

GENEL OLCU TOLERANSLARI		CİZEN	TARİH	İSİM	İMZA	HISARLAR	
DOĞRUSAL	ISO 2768-c	KONTROL	01.06.2012	Emrah DOĞAN			Eskişehir-Bursa yolu 20 km. 26550 Eskişehir / TÜRKİYE Tel : 0.222.411 24 30 Faks : 0.222.411 30 01 http://www.hisarlar.com.tr E-mail : hisarlar@hisarlar.com.tr
ACILAR	ISO 2768-c	ONAY	01.06.2012	Gökseil ATILLA			
KONUM	ISO 2768-L	PARÇA ADI					RESİM NO 172770027
YÜZEY KALİTESİ	*	KABİN KAYNAKLI KOMPLE				OLCEK	
YÜZEY İŞLEMİ	*	MALZEME				ADET	A3
CAD RESİM ÜZERİNDE ELLE DEĞİŞİKLİK YAPILMAZ OLCU ALINMAZ		MALZEME		MALZEME EBADI		BRUT AĞ/ADET	
		*		*		493Kg	1

Bu resim HISARLAR A.Ş.'ye aittir.
HISARLAR'ın yazılı izni olmadan bu resimle
üçüncü şahıslara verilmemesi ve kopya edilmemesi
Tüm yasal haklar HISARLAR A.Ş.'ye aittir.

1 2 3 4 5 6 7 8

REV	DEĞİŞİKLİK	TARİH	İSİM	ONAY
h	172770109,144,121,241,503,529,531 detay parçalara ve 172770064 kaynaklı komplekse revizyon işlenmiştir.	09.06.2015	E.DOĞAN	A.TOGAY

SANKO
MST 6

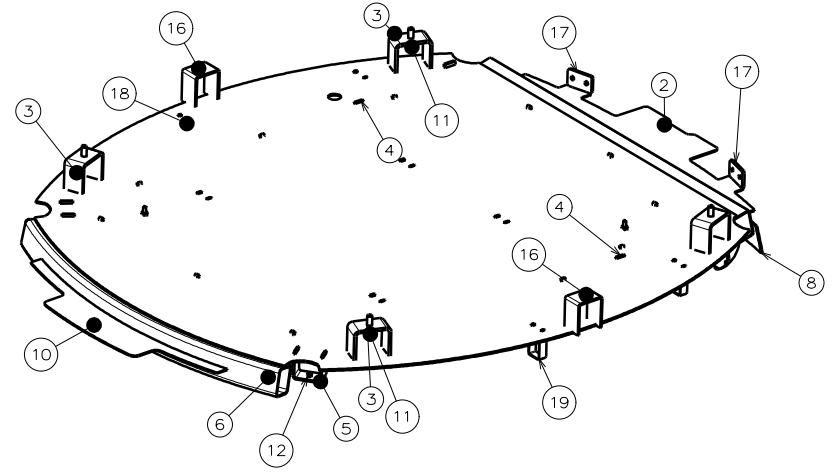
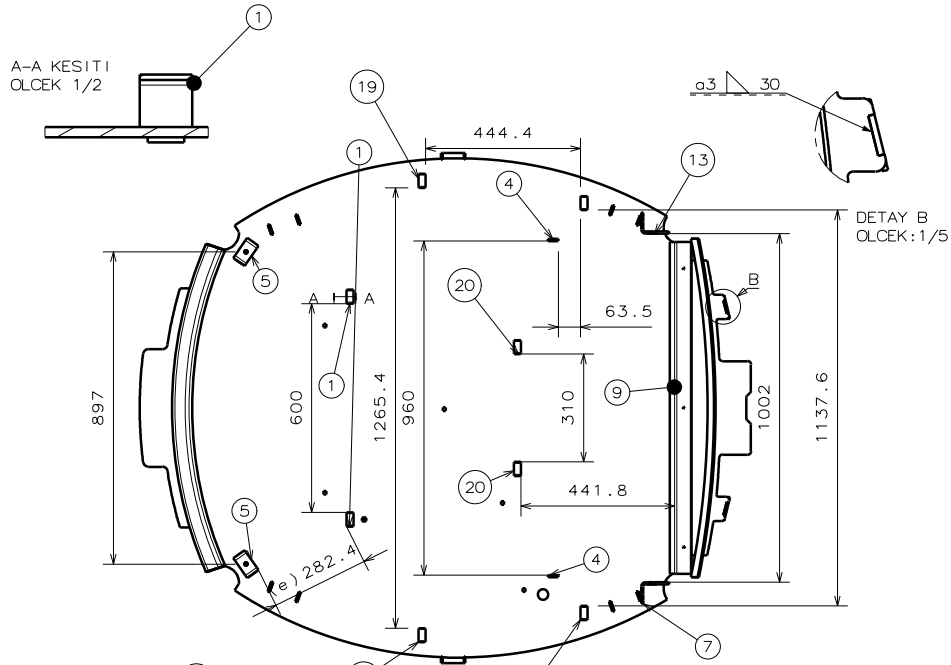

Bill of Material: 172770025

Number	Nomenclature	Quantity	Part Number	Type	Revision
2	TAVAN ARKA SACI	1	172770109	Part	
3	TAVAN DIS TRİM BRAKETİ	4	172770144	Part	
4	ARKA CERÇEVE AMORTİSORU BRAKETİ	2	172770161	Part	
5	TAVAN ÖN İC TRİM BRAKETİ	2	172770163	Part	
6	TAVAN ÖN PROFİLİ	1	172770121	Part	
7	AMORTİSOR BAĞLANTI BRAKETİ SAĞ	1	172770162	Part	
8	TAVAN ARKA ETEK SACI	1	172770240	Part	
9	TAVAN ARKA PROFİLİ	1	172770241	Part	
10	TAVAN ÖN SACI	1	172770503	Part	
12	M6 SOMUN	2	15013007	Part	
11	M12X35 Civata	4	15010313	Part	None
13	AMORTİSOR BAĞLANTI BRAKETİ SOL	1	172770191	Part	
16	TAVAN ORTA DESTEK SACI	2	172770529	Part	
17	TAVAN ARKA FAR BRAKETİ	2	172770531	Part	
1	TAVAN BAĞLANTI STOPERİ	2	172770522	Part	
19	İC DOSEME DESTEK PARÇASI-1	4	172770563	Part	
20	İC DOSEME DESTEK PARÇASI-2	2	172770564	Part	
18	TAVAN SACI KAYNAKLI KOMPLESİ	1	172770064	Assembly	

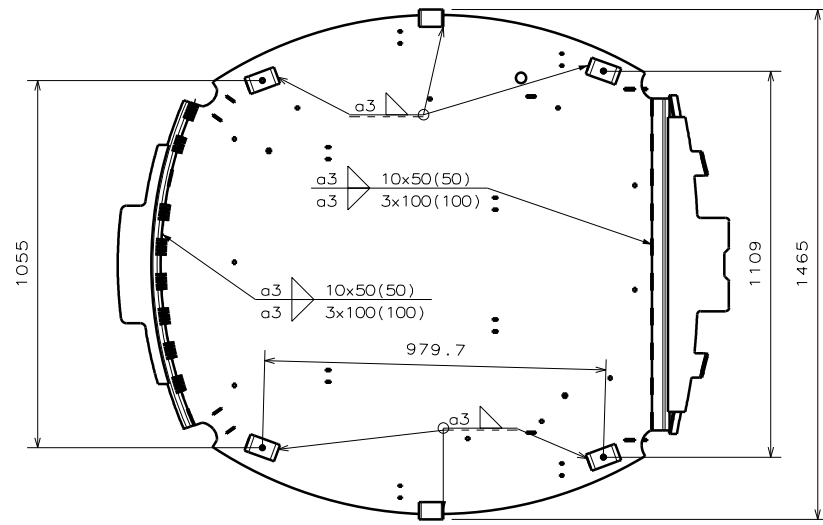
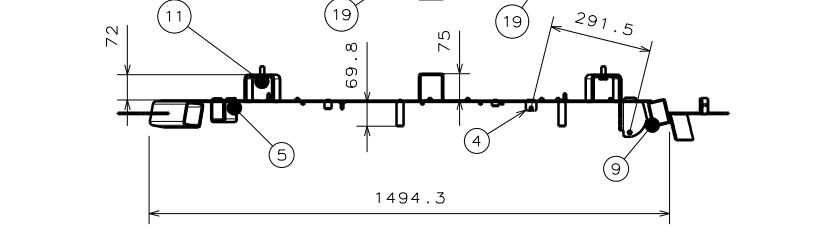

Bu resim HISARLAR PAŞA tarafından hazırlanmıştır.
HISARLARPAŞA'nın yazılımı kullanılarak hazırlanmıştır.
Tüm yasal hakları HISARLARPAŞA'ya aittir.

GENEL ÖLÇÜ TOLERANSLARI		TARİH	İSİM	İMZA	HISARLAR	
DOĞRUSAL	ISO 2768-c	KONTROL	13.07.2012	Emrah DOĞAN	Eskişehir-Bursa yolu 20 km. 26550 Eskişehir / TÜRKİYE Tel : 0.222.411 24 30 Faks : 0.222.411 30 01 http://www.hisarlar.com.tr E-mail : hisarlar@hisarlar.com.tr	
AÇILAR	ISO 2768-c	ONAY	13.07.2012	Seçil ATILLA		
KONUM	ISO 2768-L	PARÇA ADI				
YÜZEY KALİTESİ	*	TAVAN KAYNAKLI KOMPLESİ				
YÜZEY İŞLEMİ	*					
RESİM ÜZERİNDE ELLE DEĞİŞİKLİK YAPILMAZ ÖLÇÜ ALINMAZ		MALZEME	MALZEME EBADI	BRUT AĞ/ADET	ADET	RESİM NO 172770025
		*	*	*	1	OLÇEK 1/10
						SAYFA 1/1
						A3

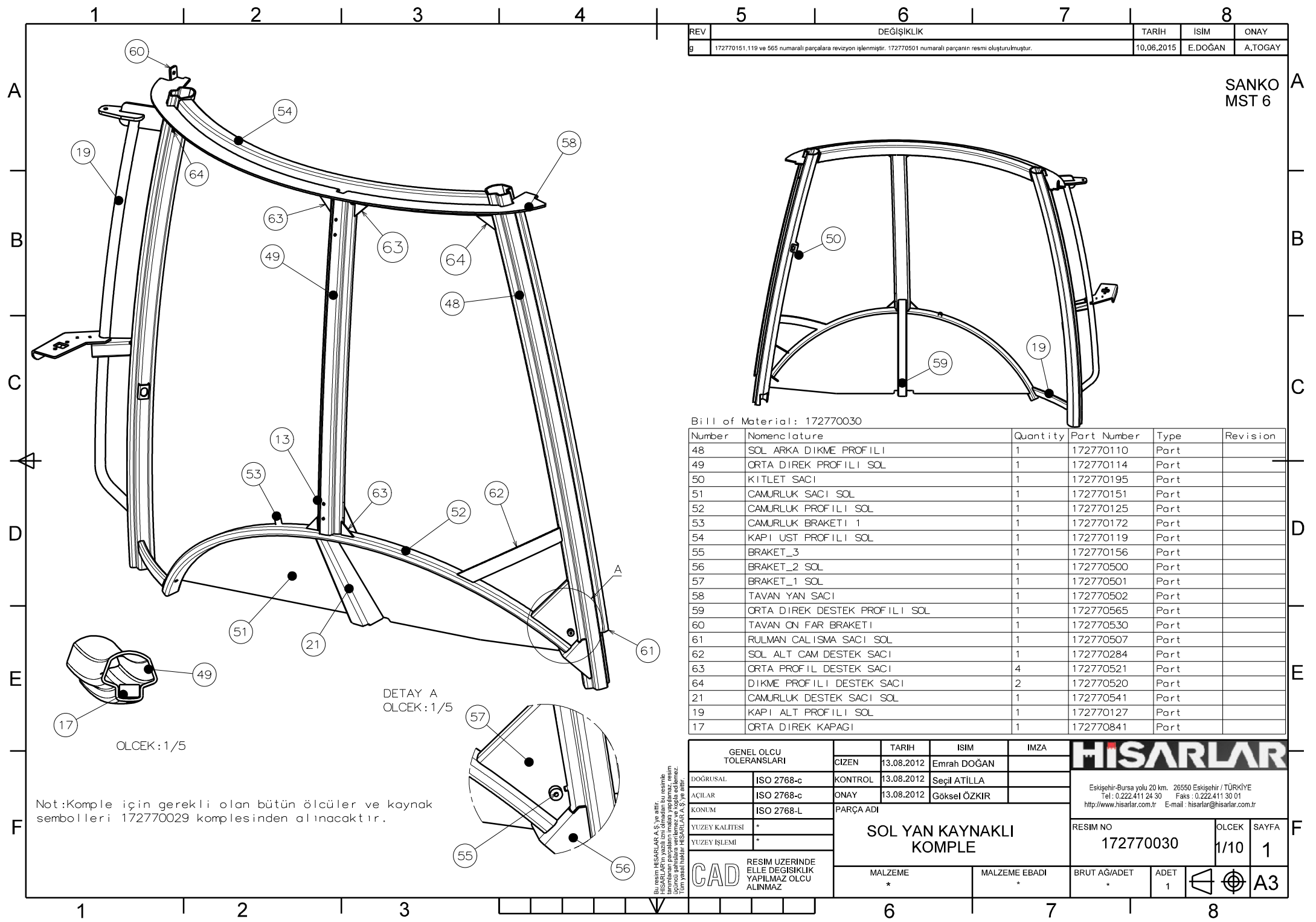

REV	DEĞİŞİKLİK	TARİH	İSİM	ONAY
g	172770151,119 ve 565 numaralı parçalara revizyon işlenmiştir. 172770501 numaralı parçanın resmi oluşturulmuştur.	10.06.2015	E.DOĞAN	A.TOGAY

SANKO
MST 6

Bill of Material: 172770030

Number	Nomenclature	Quantity	Part Number	Type	Revision
48	SOL ARKA DİKME PROFİLİ	1	172770110	Part	
49	ORTA DİREK PROFİLİ SOL	1	172770114	Part	
50	KITLET SACI	1	172770195	Part	
51	CAMURLUK SACI SOL	1	172770151	Part	
52	CAMURLUK PROFİLİ SOL	1	172770125	Part	
53	CAMURLUK BRAKETİ 1	1	172770172	Part	
54	KAPI ÜST PROFİLİ SOL	1	172770119	Part	
55	BRAKET_3	1	172770156	Part	
56	BRAKET_2 SOL	1	172770500	Part	
57	BRAKET_1 SOL	1	172770501	Part	
58	TAVAN YAN SACI	1	172770502	Part	
59	ORTA DİREK DESTEK PROFİLİ SOL	1	172770565	Part	
60	TAVAN ÖN FAR BRAKETİ	1	172770530	Part	
61	RULMAN CALI İSMA SACI SOL	1	172770507	Part	
62	SOL ALT CAM DESTEK SACI	1	172770284	Part	
63	ORTA PROFİL DESTEK SACI	4	172770521	Part	
64	DİKME PROFİLİ DESTEK SACI	2	172770520	Part	
21	CAMURLUK DESTEK SACI SOL	1	172770541	Part	
19	KAPI ALT PROFİLİ SOL	1	172770127	Part	
17	ORTA DİREK KAPAGI	1	172770841	Part	

DETAY A
ÖLÇEK: 1/5

ÖLÇEK: 1/5

Not:Komple için gerekli olan bütün ölçüler ve kaynak sembolleri 172770029 kompleksinden alınacaktır.

Bu resim HİSARLAR A.Ş.'ye aittir.
HİSARLAR'ın yazılı izni olmadan bu resimle ilgili hiçbir şekilde yayımlanma veya kopyalama yapılamaz.
Tüm yasal hakları HİSARLAR A.Ş.'ye aittir.

GENEL ÖLÇÜ TOLERANSLARI		TARİH	İSİM	İMZA	HİSARLAR
DOĞRUSAL	ISO 2768-c	13.08.2012	Emrah DOĞAN		
ÇİCEN		KONTROL	13.08.2012	Seçil ATILLA	
ACILAR	ISO 2768-c	ONAY	13.08.2012	Gökseki ÖZKIR	
KONUM	ISO 2768-L	PARÇA ADI			
YÜZEY KALİTESİ	*	SOL YAN KAYNAKLI KOMPLE			
YÜZEY İŞLEMİ	*				
RESİM ÜZERİNDE ELLE DEĞİŞİKLİK YAPILMAZ ÖLÇÜ ALINMAZ		MALZEME	MALZEME EBADI	BRUT AĞ/ADET	RESİM NO
CAD		*	*	*	172770030
				1	ÖLÇEK
					1/10
					SAYFA
					1
					ÖLÇÜ
					A3

REV	DEĞİŞİKLİK	TARİH	İSİM	ONAY
h	172770154 ve 156 iptal edilmiştir. 172770812 ve 571 numaralı parçalar eklenmiştir. 172770116,120,502,530 parçaları ile 172770051 kompleksine revizyon işlenmiştir.	10.06.2015	E.DOĞAN	A.TOGAY

SANKO
MST 6

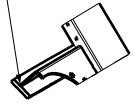
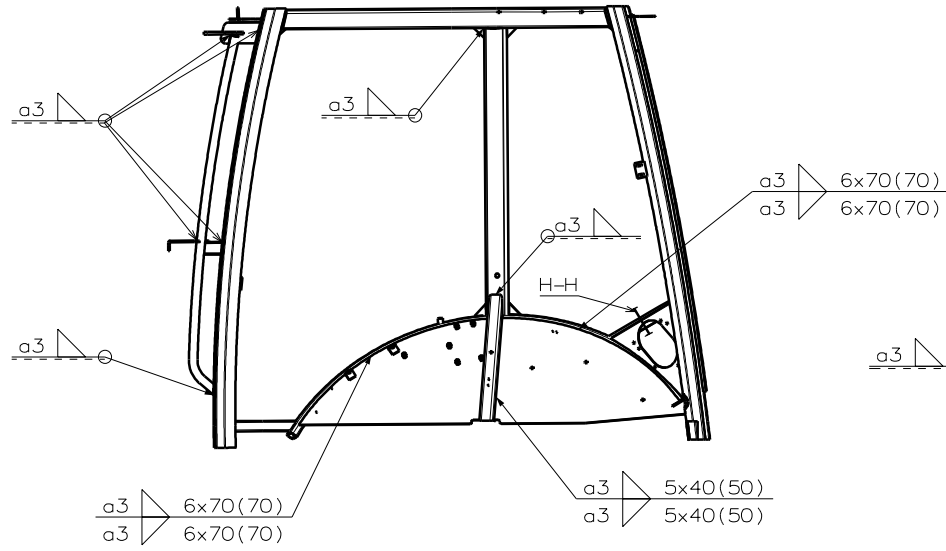
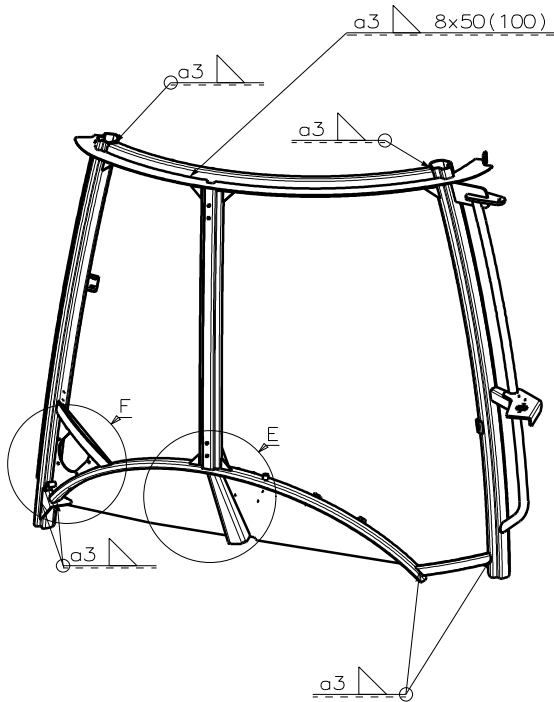

H-H KESİTİ

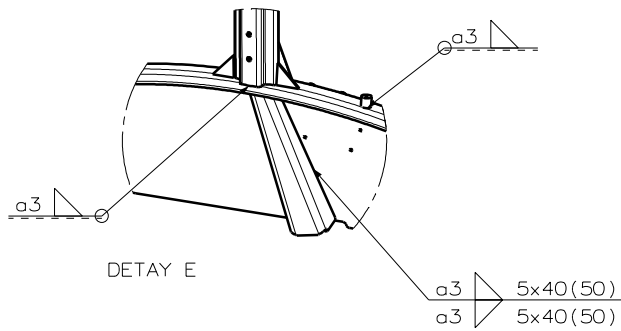

DETAY E

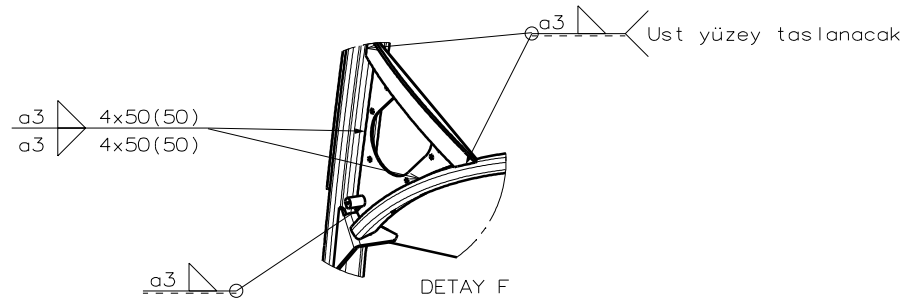

DETAY F

GENEL OLCU TOLERANSLARI		TARİH	İSİM	İMZA	HISARLAR
DOĞRUSAL	ISO 2768-c	CİZEN	13.08.2012	Emrah DOĞAN	
AÇILAR	ISO 2768-c	KONTROL	13.08.2012	Seçil ATILLA	
KONUM	ISO 2768-L	ONAY	13.08.2012	Göksel ÖZKIR	
YÜZEY KALHESİ	*	PARÇA ADI			RESİM NO 172770029
YÜZEY İŞLEMİ	*	SAG YAN KAYNAKLI KOMPLE			
CAD RESİM ÜZERİNDE ELLE DEĞİŞİKLİK YAPILMAZ OLCU ALINMAZ		MALZEME	MALZEME EBADI	BRUT AĞ/ADET	SAYFA 2/2
		*	*	*	A3

Bu resim HISARLAR A.Ş.'ye aittir.
HISARLAR'ın yazılı izni olmadan bu resimle
ilgili hiçbir işlem yapılamaz. Bu resim
sadece teknik amaçla kullanılmak üzere
Tüm yasal hakları HISARLAR A.Ş.'ye aittir.

Eskişehir-Bursa yolu 20 km. 26550 Eskişehir / TÜRKİYE
Tel : 0.222.411 24 30 Faks : 0.222.411 30 01
http://www.hisarlar.com.tr E-mail : hisarlar@hisarlar.com.tr



1 2 3 4 5 6 7 8

REV	DEĞİŞİKLİK	TARİH	İSİM	ONAY
h	172770154 ve 156 iptal edilmiştir. 172770612 ve 571 numaralı parçalar eklenmiştir. 172770116,120,502,530 parçaları ile 172770051 kompleksine revizyon işlenmiştir.	10.06.2015	E.DOĞAN	A.TOGAY

SANKO
MST 6

A
B
C
D
E
F

A
B
C
D
E
F

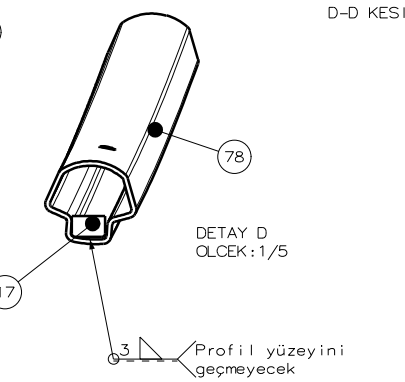
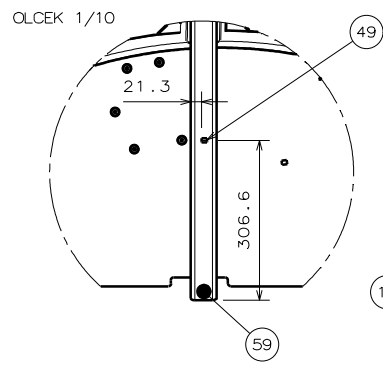
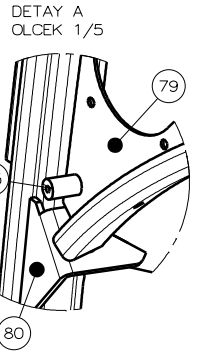
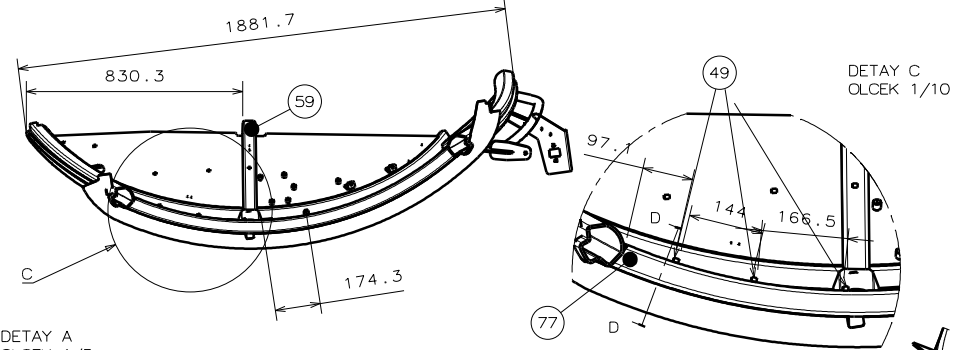
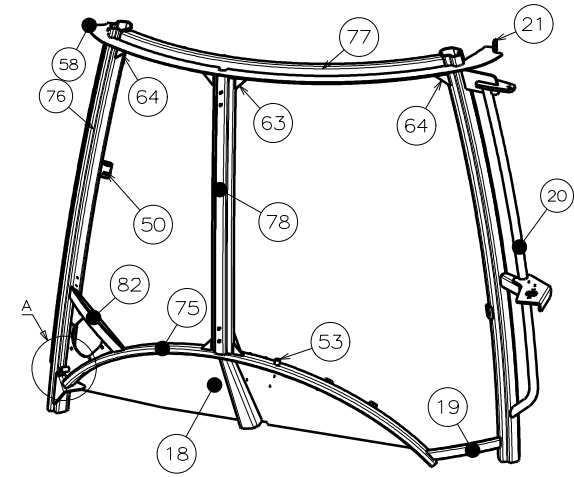
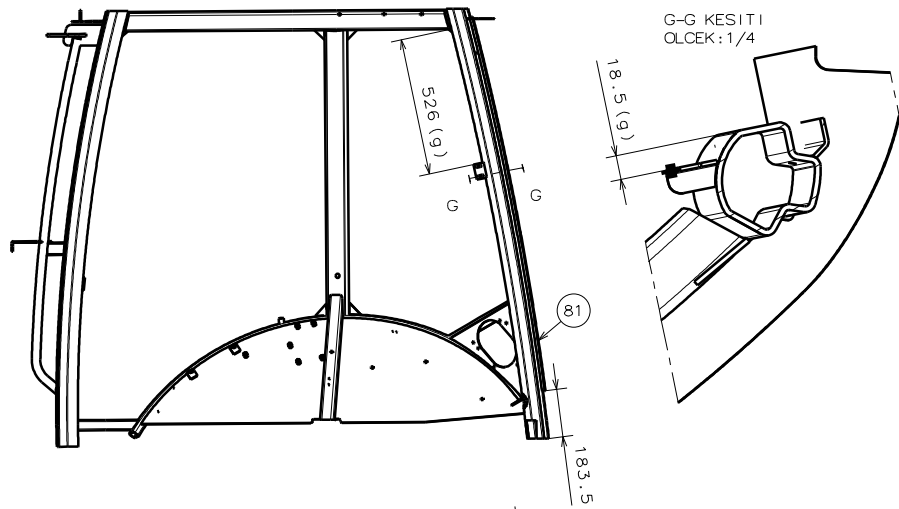

Bill of Material: 172770029

Number	Nomenclature	Quantity	Part Number	Type	Revision
75	CAMURLUK PROFİLİ SAG	1	172770124	Part	
59	ORTA DİREK DESTEK PROFİLİ	1	172770116	Part	
53	CAMURLUK BRAKETİ 1	1	172770172	Part	
76	SAG ARKA DİKME PROFİLİ	1	172770111	Part	
77	KAPI ÜST PROFİLİ SAG	1	172770120	Part	
78	ORTA DİREK PROFİLİ SAG	1	172770115	Part	
79	FİLTRE BAĞLANTI SACI	1	172770612	Part	
80	BRAKET_2 SAG	1	172770155	Part	
55	SAG CAMURLUK SOMUNU	1	172770571	Part	
58	TAVAN YAN SACI	1	172770502	Part	
50	KİTLEK SACI	1	172770195	Part	
81	RULMAN ÇALIŞMA SACI SAG	1	172770508	Part	
82	SAG ALT CAM DESTEK SACI	1	172770285	Part	
64	DİKME PROFİLİ DESTEK SACI	2	172770520	Part	
63	ORTA PROFİL DESTEK SACI	4	172770521	Part	
49	BONOLUK	4	025-1114	Part	
17	ORTA DİREK KAPAGI	1	172770841	Part	
18	SAG CAMURLUK SACI KAYNAKLI KOMPLE	1	172770051	Assembly	
19	KAPI ALT PROFİLİ SAG	1	172770126	Part	
20	SAG ON DİKME KAYNAKLI KOMPLE	1	172770053	Assembly	
21	TAVAN ON FAR BRAKETİ	1	172770530	Part	

GENEL ÖLÇÜ TOLERANSLARI		TARİH	İSİM	İMZA	HISARLAR
DOĞRUSAL	ISO 2768-c	13.08.2012	Emrah DOĞAN		
ÇIÇLAR	ISO 2768-c	13.08.2012	Seçil ATILLA		
KONUM	ISO 2768-L	13.08.2012	Göksele ÖZKIR		
YÜZEY KALİTESİ		PARÇA ADI		RESİM NO	
YÜZEY İŞLEMİ		SAG YAN KAYNAKLI KOMPLE		172770029	
RESİM ÜZERİNDE ELLE DEĞİŞİKLİK YAPILMAZ ÖLÇÜ ALINMAZ		MALZEME		BRUT AĞ/ADET	
CAD		MALZEME EBADI		ADET	
*		*		1	
				A3	

Eskişehir-Bursa yolu 20 km. 26550 Eskişehir / TÜRKİYE
Tel : 0.222.411 24 30 Faks : 0.222.411 30 01
http://www.hisarlar.com.tr E-mail : hisarlar@hisarlar.com.tr

ÖLÇEK 1/15 SAYFA 2/1

A3

Bu resim HISARLAR A.Ş.'ye aittir. İçerisindeki bilgilerin kullanılması için önceden yazılı izin alınmalıdır. Resim üzerindeki parçaların imalatı yapılmaz, resim üzerindeki saha ile uyumlu ve doğru değildir. Aynı parçaların kullanılması için yazılı izin alınmalıdır.

1 2 3 4 5 6 7 8

REV	DEĞİŞİKLİK	TARİH	İSİM	ONAY
f	172770025,172770029 ve 172770030 komplelerine revizyon işlenmiştir.	14.08.2014	E.DOĞAN	A.TOGAY
s	172770029 kompleksine revizyon işlenmiştir.172770195 numaralı parçanın tasarımını değişikliği için ilgili ölçüler değişmiştir.	08.10.2014	E.DOĞAN	A.TOGAY
t	172770025,172770029,172770030,172770026 komplelerine revizyon işlenmiştir.	11.06.2015	E.DOĞAN	A.TOGAY

SANKO
MST 6

B-B KESİTİ

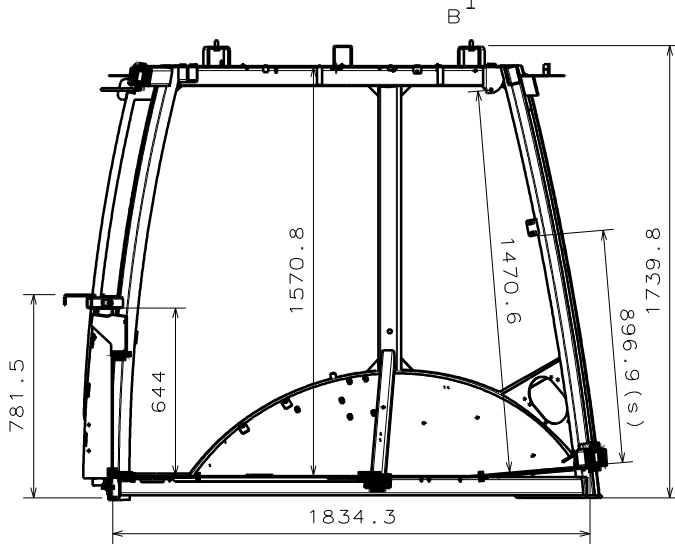
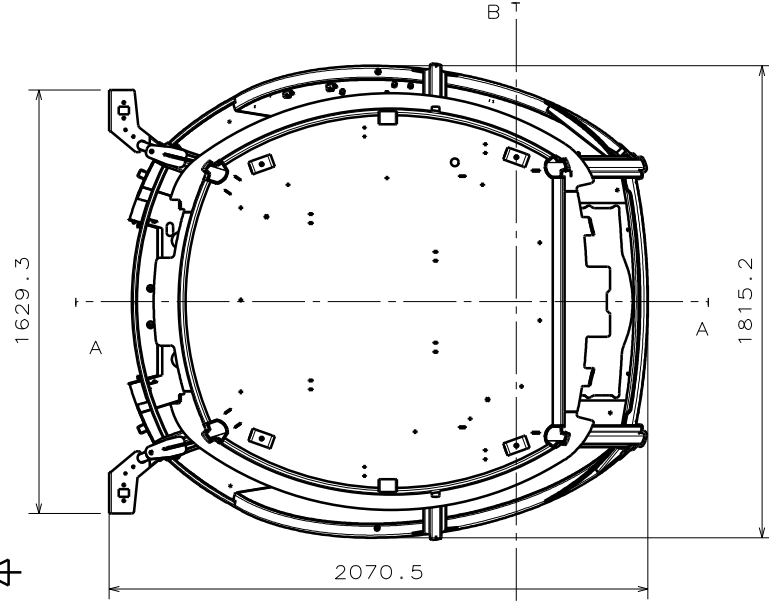
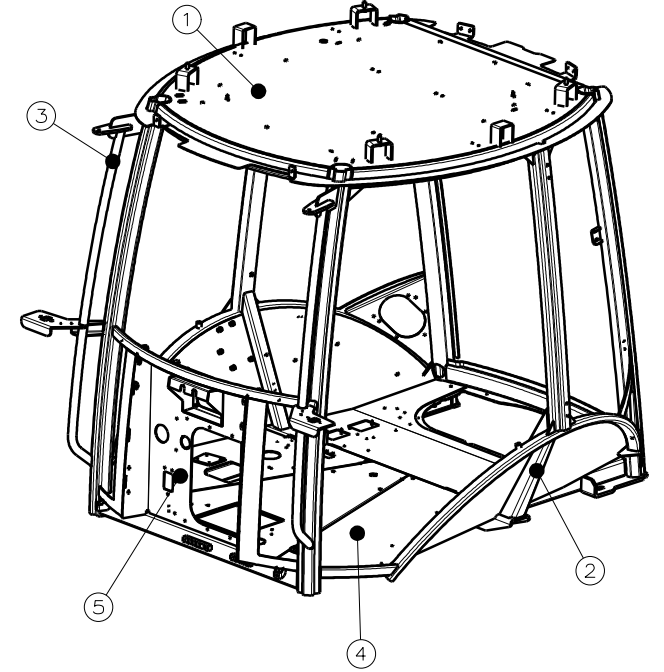
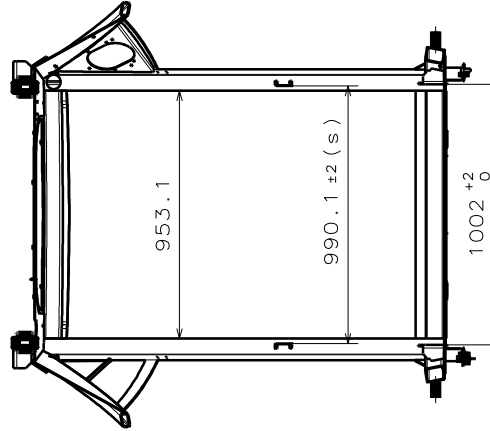

A-A KESİTİ

- Not:1-EFS 82-S005 YARIMAT SİYAH (15026006)RAL9005 Siyah+Kataforez
2-Kataforez sonrası mastik çekilecektir.
3-Ön göğüs sacında kaynaklı bulunan 8 adet M6 somun boyadan korunacaktır.

Bill of Material: 172770027

Number	Nomenclature	Quantity	Part Number	Type	Revision
1	TAVAN KAYNAKLI KOMPLESİ	1	172770025	Assembly	
2	SOL YAN KAYNAKLI KOMPLE	1	172770030	Assembly	
3	SAG YAN KAYNAKLI KOMPLE	1	172770029	Assembly	
4	TABAN KAYNAKLI KOMPLESİ	1	172770026	Assembly	
5	ÖN GÖĞÜS KAYNAKLI KOMPLESİ	1	172770028	Assembly	

GENEL OLCU TOLERANSLARI		TARİH	İSİM	İMZA	HISARLAR
CİZEN	01.06.2012	Emrah DOĞAN			
BOĞRUSAL	ISO 2768-c	KONTROL	01.06.2012	Seçil ATILLA	Eskişehir-Bursa yolu 20 km. 26550 Eskişehir / TÜRKİYE Tel : 0 222 411 24 30 Faks : 0 222 411 30 01 http://www.hisarlar.com.tr E-mail : hisarlar@hisarlar.com.tr
AÇILAR	ISO 2768-c	ONAY	01.06.2012	Göksel ÖZKIR	
KONUM	ISO 2768-L	PARÇA ADI			RESİM NO 172770027
YÜZEY KALİTESİ	*	KABİN KAYNAKLI KOMPLE			
YÜZEY İŞLEMİ	*	MALZEME			OLCEK
		MALZEME EBADI			1/20
		BRUT AĞ/ADET			SAYFA
		493Kg			2/1
		ADET			A3
		1			

Resim: HISARLAR A.Ş. ye aittir.
HISARLAR'ın yazılı izni olmadan bu resimle
benzerlik amaçlı imalat yapılmaz, resim
Tüm yazılı hakları HISARLAR A.Ş. ye aittir.

CAD RESİM ÜZERİNDE
ELLE DEĞİŞİKLİK
YAPILMAZ OLCU
ALINMAZ

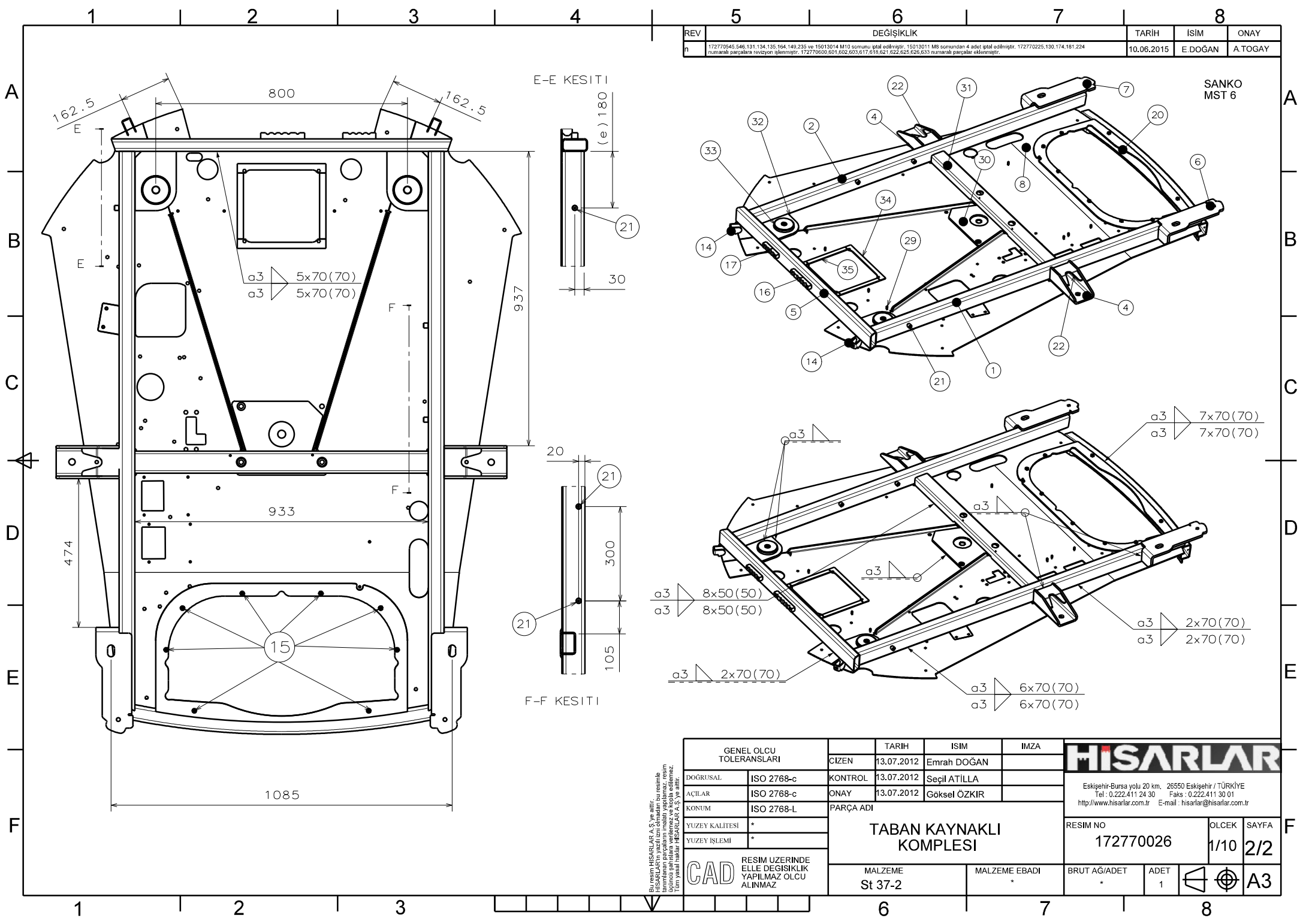

REV	DEĞİŞİKLİK	TARİH	İSİM	ONAY
n	172770045, 546, 131, 134, 135, 164, 140, 235 ve 15013014 M10 somunu iptal edilmiştir. 15012011 M8 somundan 4 adet iptal edilmiştir. 172770225, 130, 174, 181, 224 numaralı parçalara revizyon alınmıştır. 172770500, 631, 632, 633, 617, 618, 621, 622, 625, 626, 633 numaralı parçalar eklenmiştir.	10.06.2015	E.DOĞAN	A.TOGAY

SANKO
MST 6

GENEL OLCU TOLERANLARI		TARİH	İSİM	İMZA	HISARLAR	
DOĞRUSAL	ISO 2768-c	13.07.2012	Emrah DOĞAN			
AÇILAR	ISO 2768-c	KONTROL	13.07.2012	Seçil ATILLA	Eskişehir-Bursa yolu 20 km. 26550 Eskişehir / TÜRKİYE Tel : 0.222.411 24 30 Faks : 0.222.411 30 01 http://www.hisarlar.com.tr E-mail : hisarlar@hisarlar.com.tr	
KONUM	ISO 2768-L	ONAY	13.07.2012	Göksel ÖZKIR		
YÜZEY KALİTESİ	*	PARÇA ADI				
YÜZEY İŞLEMİ	*	TABAN KAYNAKLI KOMPLESİ			RESİM NO	
					172770026	
		MALZEME	MALZEME EBADI	BRUT AĞ/ADET	OLCEK	SAYFA
		St 37-2	*	*	1/10	2/2
				ADET	A3	
				1		

Bu resim HISARLAR A.Ş.'ye aittir.
HISARLAR'ın yazılı izni olmadan, bu resimle
ilgili hiçbir şekilde çoğaltım, yayım, kopyalama,
yayın, imajlama, telif hakkı ihlali veya başka şekilde
Tüm yasal haklar HISARLAR A.Ş.'ye aittir.

CAD RESİM ÜZERİNDE
ELLE DEĞİŞİKLİK
YAPILMAZ OLCU
ALINMAZ

DETAY A
OLCEK 1/5

DETAY B
OLCEK 1/5

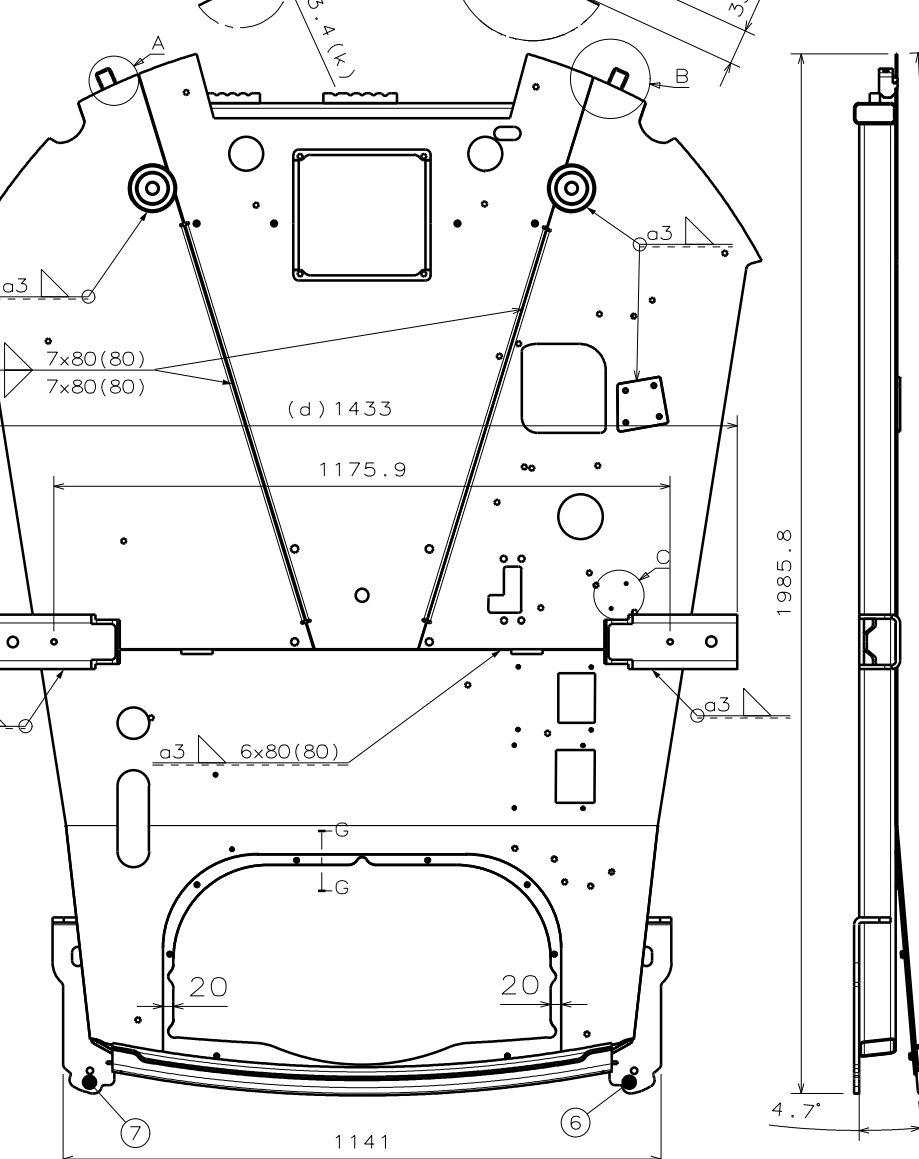

REV	DEĞİŞİKLİK	TARİH	ISIM	ONAY
0	172770545,546,131,134,135,154,140,235 ve 15013014 M10 somunu iptal edilmiştir, 15013011 M8 somundan 4 adet iptal edilmiştir, 172770225,130,174,181,224 numaralı parçalara revizyon işlenmiştir, 172770600,001,002,003,017,018,021,022,025,026,033 numaralı parçalar eklenmiştir.	10.06.2015	E.DOĞAN	A.TOGAY

SANKO
MST 6

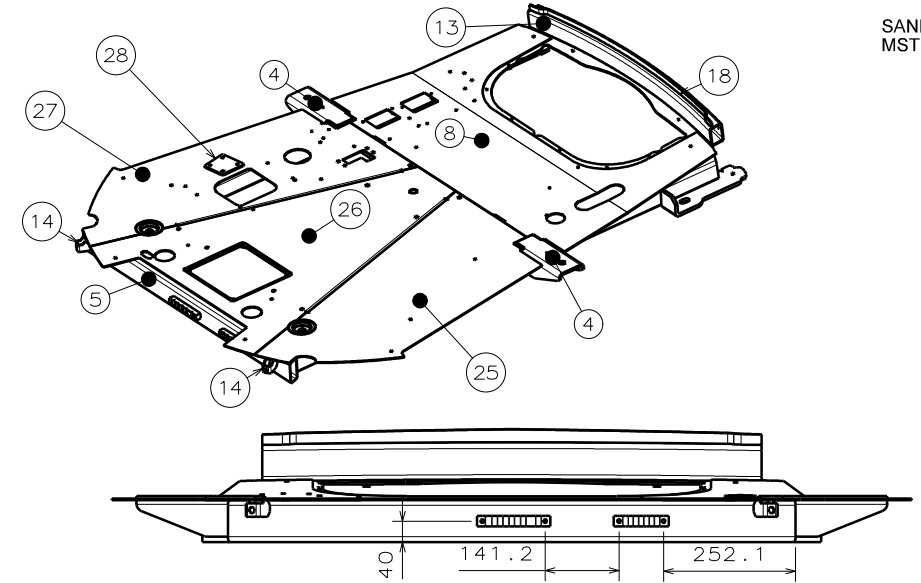

Bill of Material: 172770026

Number	Nomenclature	Quantity	Part Number	Type	Revision
1	TABAN PROFİLİ SAG	1	172770225	Part	
2	TABAN PROFİLİ SOL	1	172770130	Part	
4	PROFİL DESTEK SACI	2	172770132	Part	
5	TABAN ON PROFİLİ	1	172770174	Part	
6	ARKA TABAN DESTEK SACI SAG	1	172770224	Part	
7	ARKA TABAN DESTEK SACI SOL	1	172770181	Part	
13	TABAN ARKA PROFİLİ	1	172770123	Part	
15	DIN934 M8 SOMUN	8	15013010	Part	
16	DİREKSİYON KOLONU BORU KELEPÇESİ	1	172106119	Part	
17	FREN VALF BORU KELEPÇESİ	1	172106111	Part	
18	ARKA CERÇEVE ALT FİTİL SACI	1	172770506	Part	
20	ARKA SERVİS KAPAGI CERÇEYESİ	1	172770259	Part	
21	SİGORTA BAĞLANTI SOMUNU	3	172770252	Part	
14	ON DİŞ TRİM BAĞLANTI BRAKETİ	2	172770165	Part	
22	ROPS DESTEK SACI	2	172770542	Part	
8	ARKA TABAN SACI	1	172770603	Part	
25	KABİN TABANI ON SOL	1	172770600	Part	
26	KABİN TABANI ORTA SACI	1	172770601	Part	
27	TABAN SACI SAG	1	172770602	Part	
28	REXROTH JOYS. BAĞLANTISI	1	172770633	Part	
29	M6 X30 SEKTRÜR , DİN 913	14	10004032	Part	
30	KOLUK ALT BAĞLANTISI	1	172770625	Part	
31	KABİN ALT DESTEK SACI	1	172770626	Part	
32	KABİN BAĞLANTI DESTEK SACI	2	172770617	Part	
33	ON KABİN TAKOZ BAĞLANTISI	2	172770618	Part	
34	ON CERÇEVE SACI-1	2	172770621	Part	
35	ON CERÇEVE SACI-2	2	172770622	Part	

GENEL OLCU TOLERANSLARI		TARİH	ISIM	IMZA
DOĞRUSAL	ISO 2768-c	CİZEN	13.07.2012	Emrah DOĞAN
AÇILAR	ISO 2768-c	KONTROL	13.07.2012	Seçil ATILLA
KONUM	ISO 2768-L	ONAY	13.07.2012	Göksef ÖZKIR
YÜZEY KALİTESİ	*	PARÇA ADI		
YÜZEY İŞLEMİ	*	TABAN KAYNAKLI KOMPLESİ		
RESİM ÜZERİNDE ELLE DEĞİŞİKLİK YAPILMAZ OLCU ALINMAZ				
MALZEME		MALZEME EBAĐI		BRUT AĞ/ADET
St 37-2		*		ADET
				1

HISARLAR

Eskişehir-Bursa yolu 20 km. 26550 Eskişehir / TÜRKİYE
Tel : 0 222 411 24 30 Faks : 0 222 411 30 01
http://www.hisarlar.com.tr E-mail : hisarlar@hisarlar.com.tr

RESİM NO	OLCEK	SAYFA
172770026	1/10	2/1
BRUT AĞ/ADET	ADET	
*	1	

HISARLAR A.Ş. Ye. Atilla
Eskişehir/Bursa yolu 20 km. 26550 Eskişehir / TÜRKİYE
Tel : 0 222 411 24 30 Faks : 0 222 411 30 01
http://www.hisarlar.com.tr E-mail : hisarlar@hisarlar.com.tr

CAD

A3