

# SF<sub>6</sub>-insulated circuit-breaker panel

Type GAE630 -1LSV(G)630-/5/  
in modular extensible design, up to 24 kV

OPERATING INSTRUCTIONS

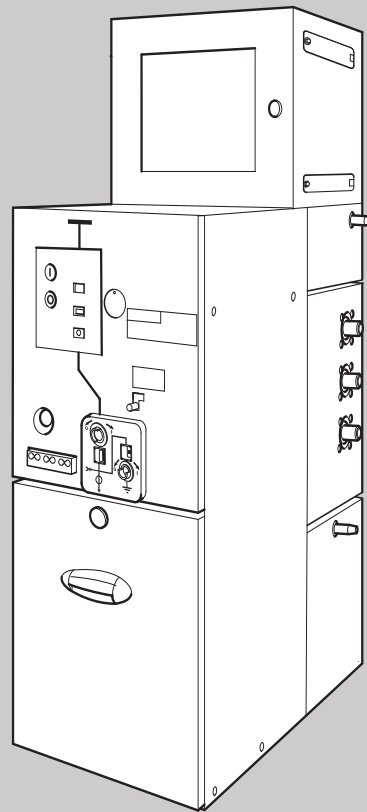



# Table of contents

<b>1</b>	<b>General</b> .....	<b>8</b>	<b>6</b>	<b>Commissioning</b> .....	<b>41</b>
1.1	Liability and warranty .....	8	6.1	Inspection activities and safety instructions	41
1.2	Service information .....	8	6.2	Switching the circuit-breaker panel (manually) .....	41
<b>2</b>	<b>Safety regulations</b> .....	<b>9</b>	6.3	Undervoltage release (optional) .....	41
2.1	Intended use .....	9	6.4	Switching using motor drive (option) .....	42
2.2	Explanation of symbols and notes .....	9	6.5	Checking for electrical isolation .....	42
2.3	General health and safety instructions .....	10	6.6	Phase comparison .....	43
2.3.1	Operation .....	10	6.7	Cable test .....	44
2.3.2	Safety features .....	10	<b>7</b>	<b>Maintenance</b> .....	<b>45</b>
2.3.3	Auxiliary device for operation, maintenance and repair .....	10	7.1	General .....	45
2.3.4	Statutory health and safety instructions .....	10	7.2	Inspection and maintenance .....	45
<b>3</b>	<b>Transport and installation</b> .....	<b>11</b>	7.2.1	Inspection .....	45
3.1	Safety notes for transport .....	11	7.2.2	Maintenance .....	46
3.2	Transport and unloading .....	11	7.2.3	Cleaning the circuit-breaker panel .....	46
3.3	Arrival and unpacking .....	12	7.2.4	Scope of maintenance on the vacuum circuit-breaker's mechanical drive groups .....	46
3.4	Storage .....	13	7.3	Fault clearance on the vacuum circuit-breaker .....	47
3.5	Installation and assembly .....	14	7.4	Return of switchgear .....	47
3.6	Planning of installation .....	15	<b>8</b>	<b>Technical data</b> .....	<b>48</b>
3.6.1	Floor fastening measurements .....	15	8.1	General data .....	48
3.6.2	Dimensions .....	16	8.2	Circuit-breaker panel GAE630 -1LSV(G)630 ratings .....	48
3.6.3	Possible installations .....	17	8.3	Switchgear ratings .....	49
3.7	Installation of the supply line for the auxiliary and control circuits .....	18	8.4	Processing time guide values .....	49
3.8	Connection of the power cables .....	19	8.5	Release and blocking magnet .....	49
3.9	Attachments .....	20	8.6	Motor winder .....	50
3.10	Earthing .....	21	8.7	Permissible number of operating cycles .....	50
<b>4</b>	<b>Technical description</b> .....	<b>22</b>	8.8	Tightening torques .....	51
4.1	Circuit-breaker panel .....	22	8.9	Materials .....	51
4.2	Extension of the circuit-breaker panel .....	23	8.10	Auxiliary and operating materials for circuit-breakers .....	51
4.3	Gas tank .....	24	8.11	Regulations and standards .....	51
4.4	Gas leakage indicator .....	24	8.11.1	Test specifications .....	51
4.5	Pressure switch/density monitor (optional) .....	24	8.11.2	Female connector (bushing) .....	51
4.6	Vacuum circuit-breaker .....	24	<b>9</b>	<b>Accessories</b> .....	<b>52</b>
4.7	Three-position switch .....	26			
4.8	Three-position switch drive .....	26			
4.9	Switch panel interlocks .....	27			
4.10	Current transformer .....	28			
4.11	Capacitive voltage detecting system .....	29			
4.12	Short-circuit indicator (optional) .....	31			
<b>5</b>	<b>Operation</b> .....	<b>32</b>			
5.1	Switching accessories .....	32			
5.2	Padlocking facility .....	33			
5.3	Delivery state of the circuit-breaker panel .....	34			
5.4	Switching the circuit-breaker panel .....	35			
5.4.1	Inspection activities and safety instructions .....	35			
5.4.2	Tensioning the spring accumulator .....	36			
5.4.3	Switching the circuit-breaker panel ON .....	37			
5.4.4	Switching the circuit-breaker panel OFF .....	39			

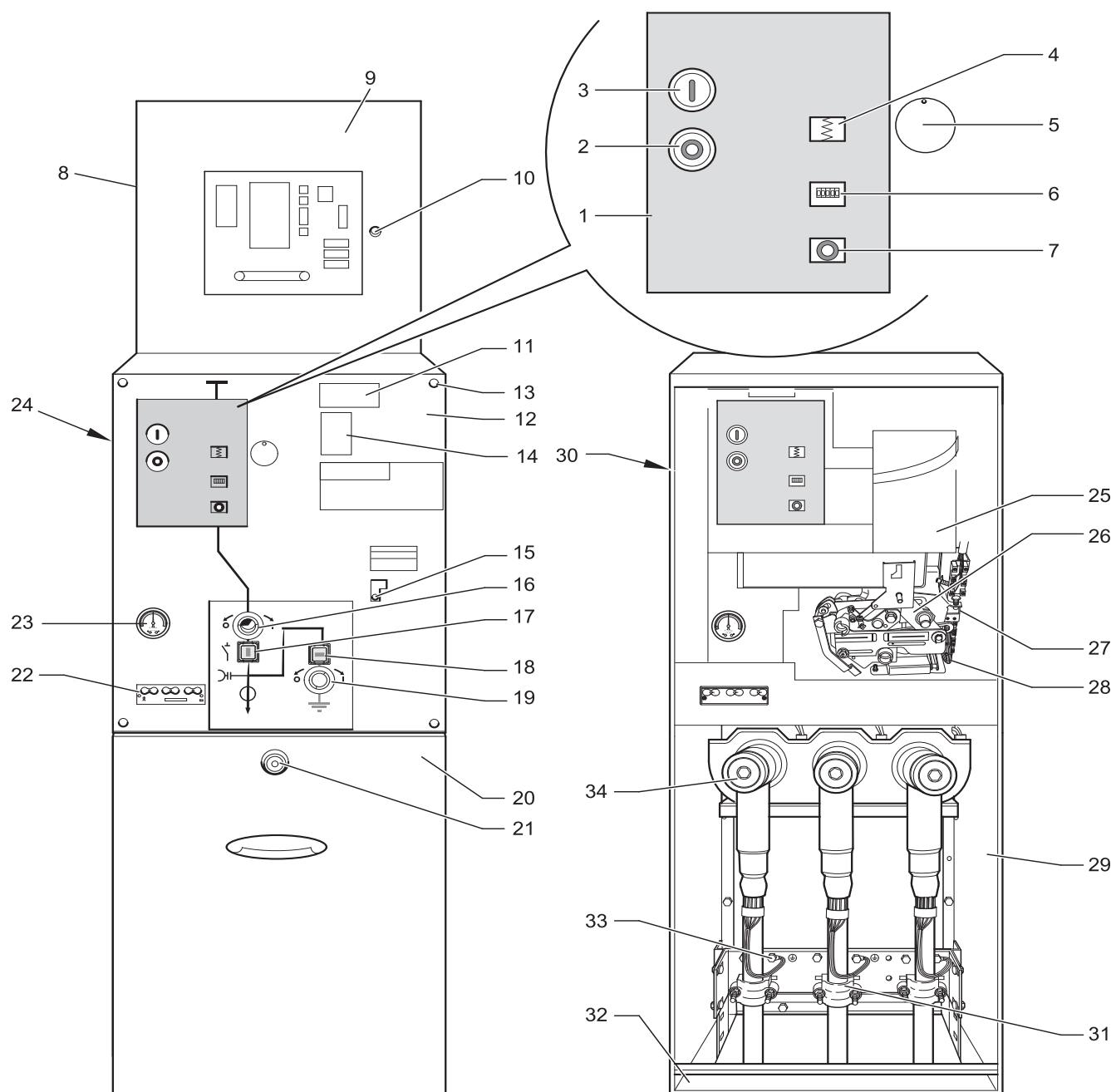

12242054 06 01

Fig. 1

- 1 Vacuum circuit-breaker control panel
- 2 OFF push-button (0 = red)
- 3 ON push-button (I = green)
- 4 Spring accumulator indicator
- 5 Spring accumulator manual winding up
- 6 Operations counter
- 7 Switch position indicator
- 8 Relay cabinet
- 9 Relay cabinet door
- 10 Relay cabinet door fastener
- 11 Panel designation
- 12 Control panel cover
- 13 Control panel cover fastening screws
- 14 Rating plate
- 15 Interlock operating lever (disconnecter circuit-breaker)
- 16 Actuating shaft disconnecter
- 17 Switch position indicator disconnecter
- 18 Switch position indicator earthing switch
- 19 Actuating shaft earthing switch
- 20 Front cover
- 21 Front cover fastener
- 22 Capacitive voltage detection system (voltage indication ledge)
- 23 Gas leakage indicator
- 24 Lifting eyes
- 25 Vacuum circuit-breaker drive
- 26 Disconnecter/earthing switch drive
- 27 Auxiliary switch bar earthing switch
- 28 Auxiliary switch bar disconnecter
- 29 Cable connection compartment
- 30 SF<sub>6</sub>-gas tank
- 31 Cable fixing iron
- 32 Pedestal
- 33 System earthing
- 34 T-connector for VPE-cable

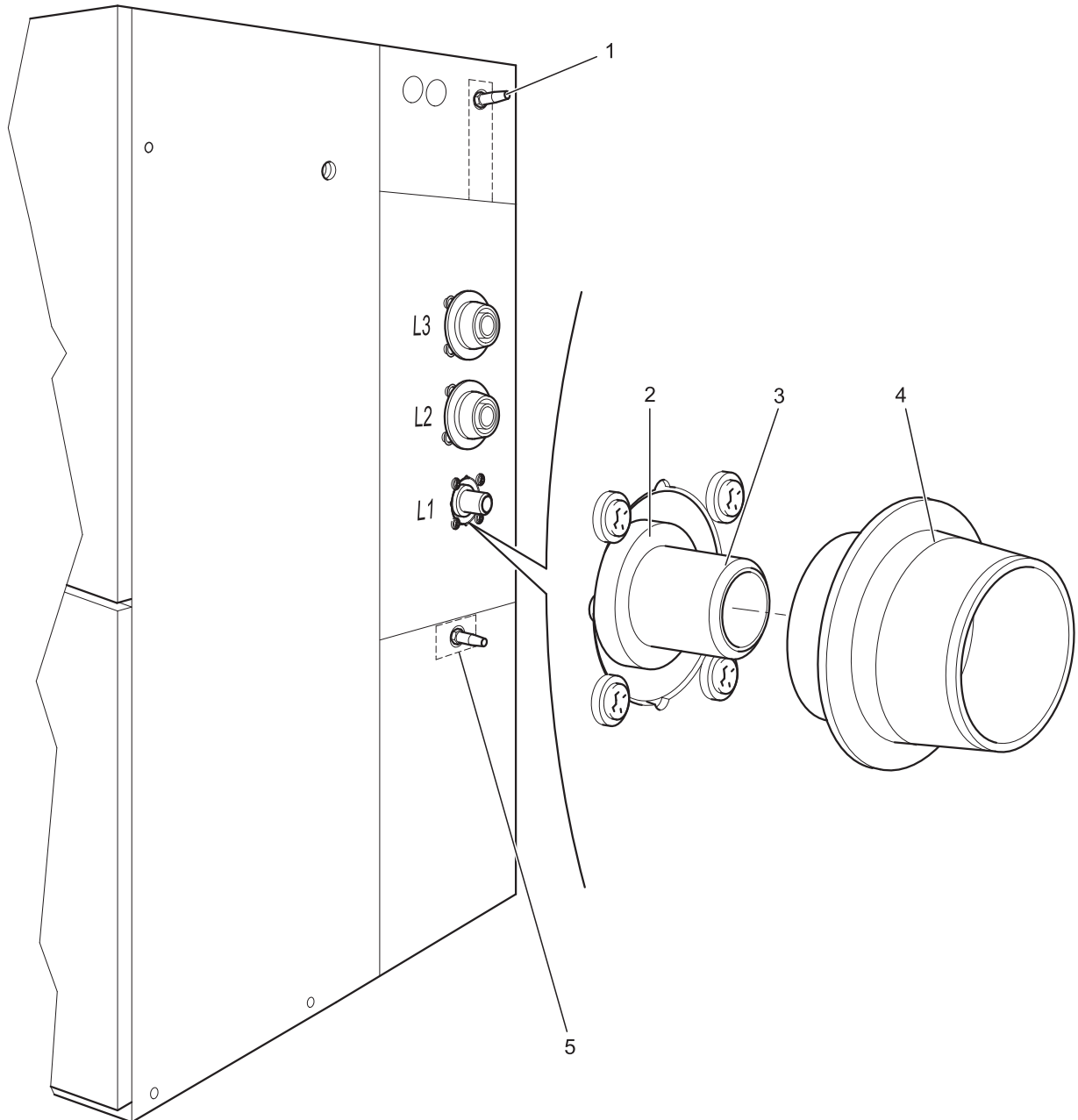

12242054 06 02

Fig. 2

- 1 Top panel screw connection  
(guide pin)
- 2 Bushing with contact springs
- 3 Contact bolt
- 4 Double seal
- 5 Bottom panel screw connection  
(guide pin)

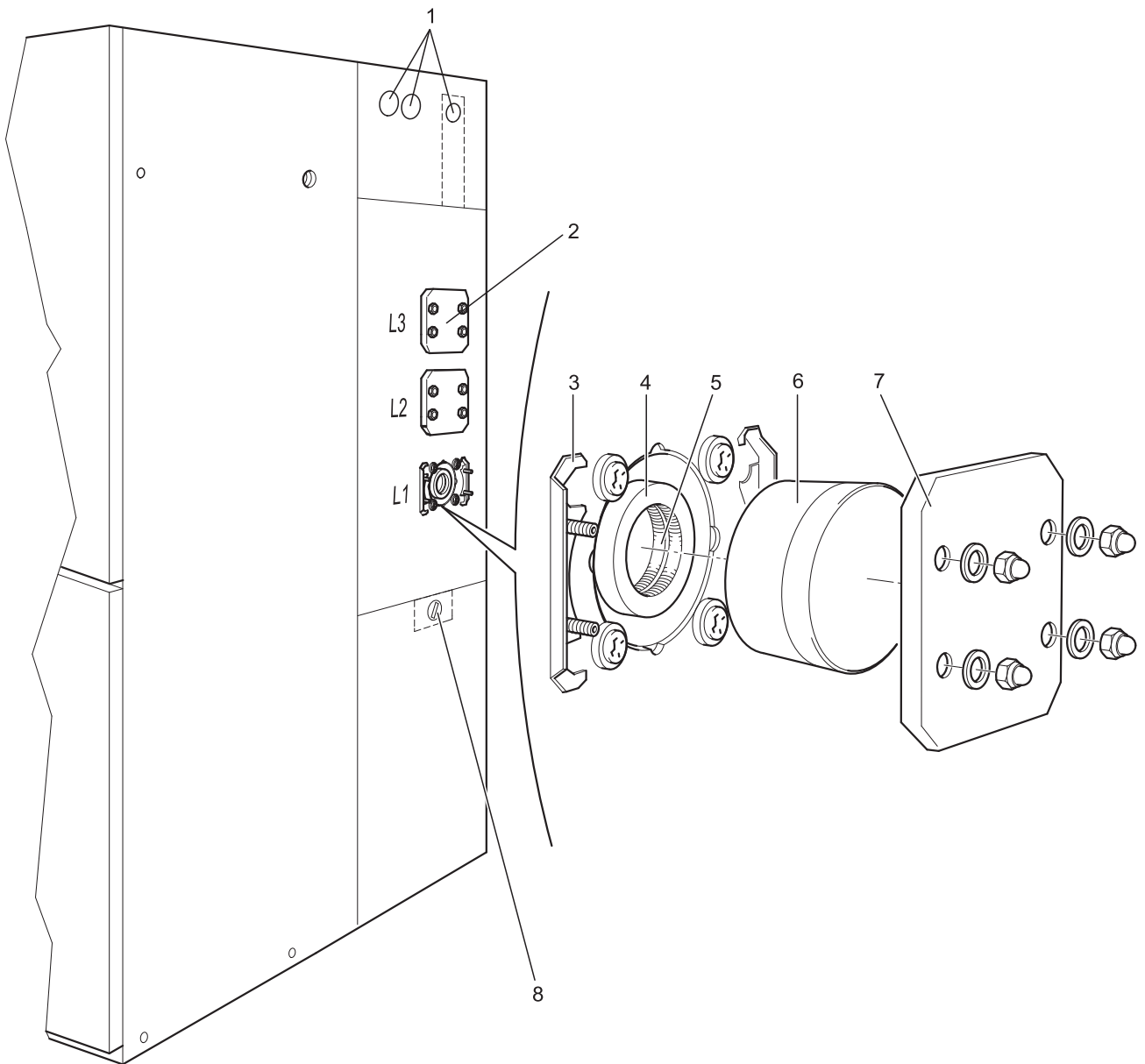

12242054 06 03

Fig. 3

- |   |                               |   |                 |
|---|-------------------------------|---|-----------------|
| 1 | Sealing plug                  | 5 | Contact springs |
| 2 | Sealing end side bushing      | 6 | Single seal     |
| 3 | Clamping sheet                | 7 | Cover           |
| 4 | Busbar bushing (inside taper) | 8 | Screw plug      |

# 1 General

## 1.1 Liability and warranty

All information and notes concerning operation and maintenance of the circuit-breaker panel are provided under due consideration of our present experience and to the best of our knowledge. These instructions describe the standard circuit-breaker panel.

All technical information and data contained in these operating instructions are up to date at the day of printing. We reserve the right to make technical changes in the course of further development without the need to change these instructions.

Therefore, no claims can be made based on the information and descriptions in these instructions.

We will not assume liability for damage or malfunctions resulting from operating errors, failure to observe these operating instructions or incorrect repairs.

Genuine spare parts from Ormazabal have been specially designed and tested for Ormazabal circuit-breaker panels.

It is highly recommended to purchase spare parts and accessories only from Ormazabal. We would like to make explicitly clear, that any spare parts and accessories not supplied by us require the approval by Ormazabal.

The assembly and use of other products may have a negative effect on design specific characteristics of the circuit-breaker panel and thereby impair the safety for man, circuit-breaker panel or other property.

For damage resulting from the use of spare parts and accessories not approved by Ormazabal any liability by Ormazabal is excluded.

Any unauthorized conversions and changes to the circuit-breaker panels are prohibited for safety reasons and cause the exclusion of any liability by Ormazabal for any damage resulting from this.

## 1.2 Service information

The customer service department of Ormazabal is always available for any technical information on Ormazabal circuit-breaker panels.

Should you encounter any difficulties with our equipment, please contact the local manufacturing plant. The address of the local manufacturing branch can be found on the last page of these operating instructions.

## 2 Safety regulations

### 2.1 Intended use

The GAE630 circuit-breaker panel is a prefabricated, type approved, metal-enclosed, interior switching panel for use in accessible switchgear rooms and an operating voltage of up to 24 kV.

It can be extended using series GAE panel / block modules.

Circuit-breaker panels are used in:

- transformer stations
- node stations
- combined heating and power plants
- industrial plants
- customer consumer installations
- wind energy converters.

The circuit-breaker panel GAE630 -1LSV630- is used to switch:

- overhead lines and cables
- transformers
- motors
- generators
- choke coils.

The GAE630 circuit-breaker panel is used as a bus sectionaliser panel GAE630 -1LSVG630-.

The circuit-breaker panel must only be operated, serviced and repaired by authorised personnel, who have been instructed or trained accordingly.

These operating instructions must be read carefully and strictly observed before installing and commissioning the circuit-breaker panel.

Every person involved in the installation, commissioning, operation, maintenance and repair of the unit must have read and understood these operating instructions, especially the chapter on safety and any other safety instructions.

We recommend that the user/owner obtains written confirmation of compliance with this requirement.

Only the exact knowledge of these operating instructions helps to avoid operating errors and ensures trouble-free operation.

The general safety and accident prevention instruction issued by the legislator and possible regulations of the insurer, which may be different from country to country, must be strictly observed when operating and servicing the circuit-breaker panel.

These operating instructions are part of the circuit-breaker panel. When passing on the circuit-breaker panel (relocation, selling or similar) the operating instructions must also be handed over.

### 2.2 Explanation of symbols and notes

Observe these instructions and exercise extreme care in such cases. Hand out all notes on health and safety also to all persons who are involved in work on the equipment. Besides the notes in these operating instructions you must also comply with the generally valid safety and accident prevention instructions (e. g. DIN EN 50110, VDE 0105 part 100, BGV A3).



#### Health and safety symbols

You will find these symbols with all health and safety instructions in these operating instructions in which reference is made to hazards for personnel.



#### Warning about risk of electric voltage

This special health and safety symbol warns against dangers due the risk of electric voltage.

#### Attention!

#### Cautionary instruction

In these operating instructions this note appears at all points which must be especially observed in order to comply with guidelines, instructions and the correct work sequence, thereby avoiding damage and destruction of the circuit-breaker panel.

## 2.3 General health and safety instructions

The circuit-breaker panel is designed and manufactured to the latest technical standards and with due consideration of all safety instructions.

However, dangers for people and property may arise from these circuit-breaker panels if they are used incorrectly by untrained personnel or for purposes they are not intended for, if they are manipulated or if the safety regulations are disregarded. For this reason every person involved in the installation, commissioning, operation or maintenance of the circuit-breaker panel must have read and understood these instructions.

### 2.3.1 Operation

When operating the circuit-breaker panel the responsibilities must be clearly defined and observed, so that no unclear areas of responsibility in relation to safety arise.

Before commissioning the circuit-breaker panel and after service work or modifications the circuit-breaker panel must be inspected by qualified personnel for safe working condition.

Before commissioning, all personnel in the danger zone around the circuit-breaker panel must be warned and asked to leave this area. There must not be any objects blocking the access to the controls.

The user must operate the circuit-breaker panel only in perfect condition.

Any changes that degrade safety must be reported immediately to the supervisor.

Changes to the circuit-breaker panel are only permitted in coordination with Ormazabal and under the supervision of expert personnel.

Specialist personnel are persons who, due to their professional training and experience, have sufficient knowledge in the field of electrical technology and are familiar with the applicable health and safety regulations (BVG A3), directives and the generally accepted technical rules and regulations (e. g. VDE-regulations, IEC-standards, DIN standards).

### 2.3.2 Safety features

Safety features must not be altered, dismantled or rendered ineffective. Unprotected parts of the system can cause fatal injuries.

All safety installations, e. g. shrouds, must always be fully functional and correctly in place. Operation of circuit-breaker panel with faulty safety features is not allowed.

### 2.3.3 Auxiliary device for operation, maintenance and repair

If any auxiliary devices (tools or similar) are required for operation, maintenance or repair of the circuit-breaker panel, these must be in safe condition and should be used in a safe way.

Any unnecessary and endangering use of auxiliary devices of any kind on the circuit-breaker panel is not permitted.

### 2.3.4 Statutory health and safety instructions

Apart from these notes on prevention of accidents and the notes attached to the circuit-breaker panel the locally valid accident prevention instructions must also be observed.

### 3 Transport and installation

#### 3.1 Safety notes for transport



1. Lifting tackle must only be used at points intended for this purpose.
2. Ropes, chains or other lifting tackle must be fitted with safety hooks.
3. Do not use any torn or worn ropes.
4. Ropes and chains must not be knotted.
5. Ropes and chains must not touch any sharp edges.
6. Only use ropes and chains of sufficient loading capacity (for weight of the circuit-breaker panel, see Chapter 8 "Technical Data", Table 5).
7. Only use lifting gear of sufficient loading capacity (for weight of the circuit-breaker panel, see Chapter 8 "Technical Data", Table 5).
8. Do not lift loads over persons.



During transport, comply with the warning and safety instructions on the circuit-breaker panel and its packaging.



When unloading observe the safety instructions (see Chap. 3.1) and the applicable accident prevention regulations.



Unloading is only allowed to be performed by experienced persons who are fully familiar with the lifting gear. Observe the permissible hoisting weight of lifting tackle and lifting gear (forklift truck, crane).

#### 3.2 Transport and unloading

The circuit-breaker panel is delivered packed upright on a pallet. It is fastened to the pallet with tightening straps (Fig. 4).

For transportation or intermediate storage, please always use the original packaging and secure the circuit-breaker panel with straps in the same way as for delivery.

When attaching the tightening straps make sure to attach these as shown in Fig. 4, as otherwise the circuit-breaker panel may be damaged.

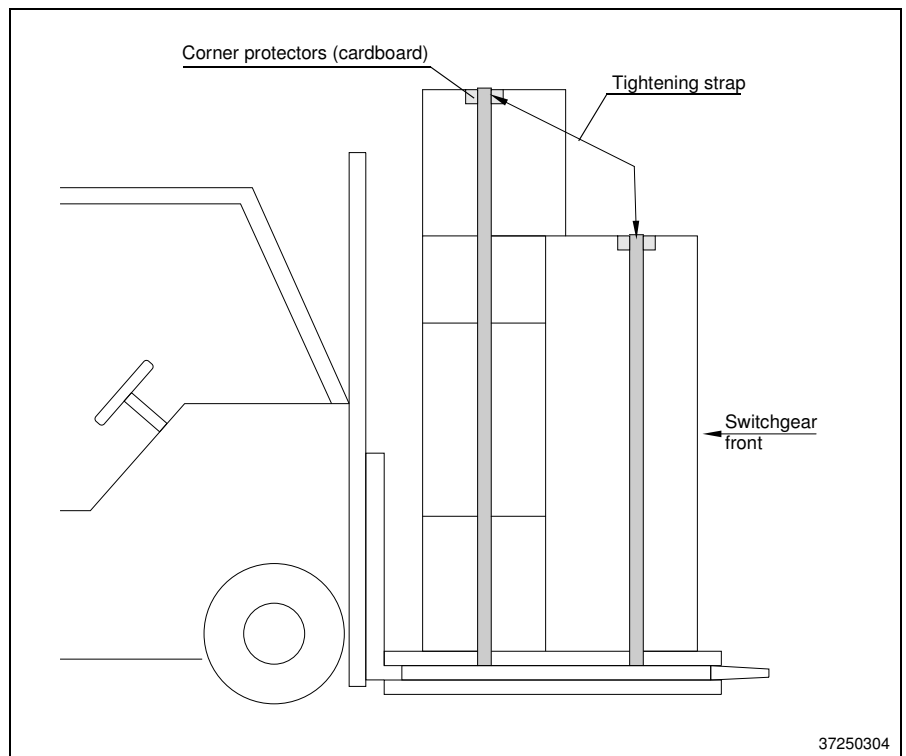

Fig. 4

### 3.3 Arrival and unpacking

Upon arrival check the circuit-breaker panel immediately for any signs of transport damage:

- **Externally visible damage** must be confirmed by the driver on the freight documents. For insurance reasons, damage must be reported in writing to the delivering freight carrier within a period of 3 days(!).
- **Hidden damage** can only be detected after removing the packaging material. Claims for transport damage found at a later date can only be accepted by us **within one week**.

Remove the tightening straps. The circuit-breaker panel is then no longer secured. Due to its design, the centre of gravity of the circuit-breaker panel is higher than the middle of the switch panel.



When handling the circuit-breaker panel in unsecured condition the unit may tip over! Particular attention is to be paid to this issue when transporting the circuit-breaker panel to its place of installation. It not allowed to use levers to transport the circuit-breaker panel to its final position. This action could cause damage to the enclosure.

Eyebolts are fitted to both sides of the GAE630 -1LSV630- panel, which hold the panel safely in its position of centre of gravity when transporting with chain or rope lifting gear (Fig. 5). Only transport cross members must be used with this type of lifting gear. Otherwise there is a risk of damage to the panel.

In some individual cases, the eyebolts are enclosed with the panel. When fitting the eyebolts, it must be observed that they are tightly seated and in the correct Fig. 5 position.

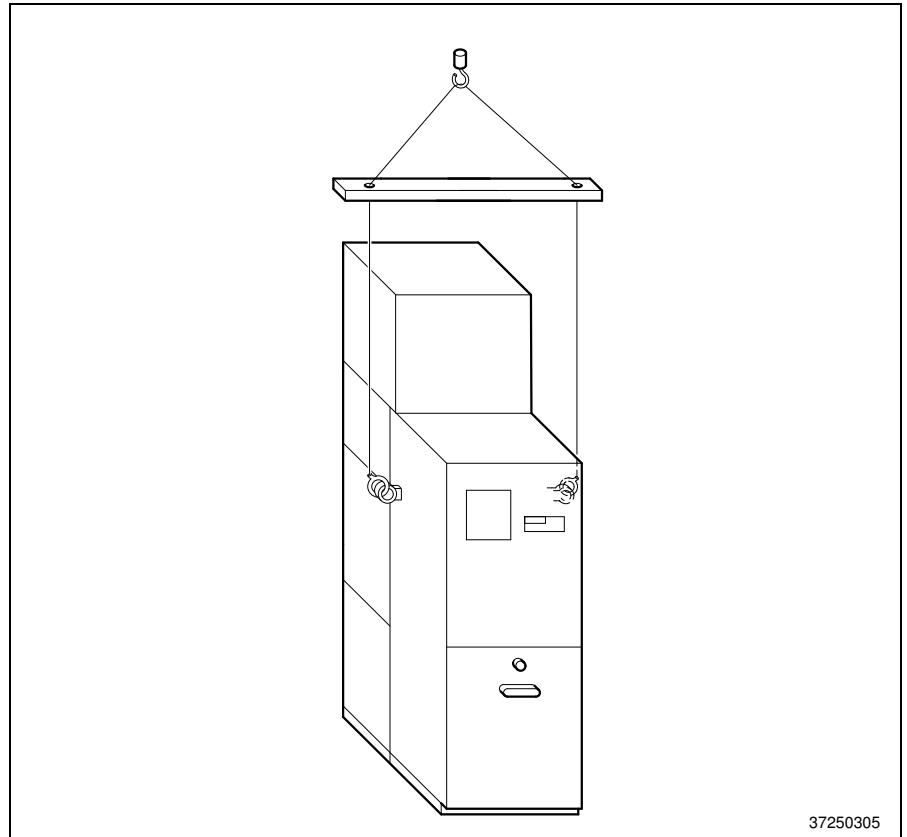

Fig. 5

37250305

After moving the circuit-breaker panel to the place of installation, remove the lifting eyes.

When installing as an end panel, close off the thread with a flexible plastic plug.

Keep the eyebolts in a safe, accessible place for future use in transporting the circuit-breaker panel. When re-fitting the eyebolts, it must be observed that they are tightly seated and in the correct position.

Check the circuit-breaker panel delivery for correctness and completeness. The serial numbers on the delivery note and on the rating plate on the circuit-breaker panel (Fig. 6) must match.

### 3.4 Storage

In the factory the circuit-breaker panel is packed ready for transport and storage. It must only be stored in dry, clean rooms and must be protected against excessive soiling.

The environmental conditions must comply with IEC 62271-1 / DIN EN 62271-1 and VDE 0670 part 1000, ambient temperature class "minus 5 indoor".

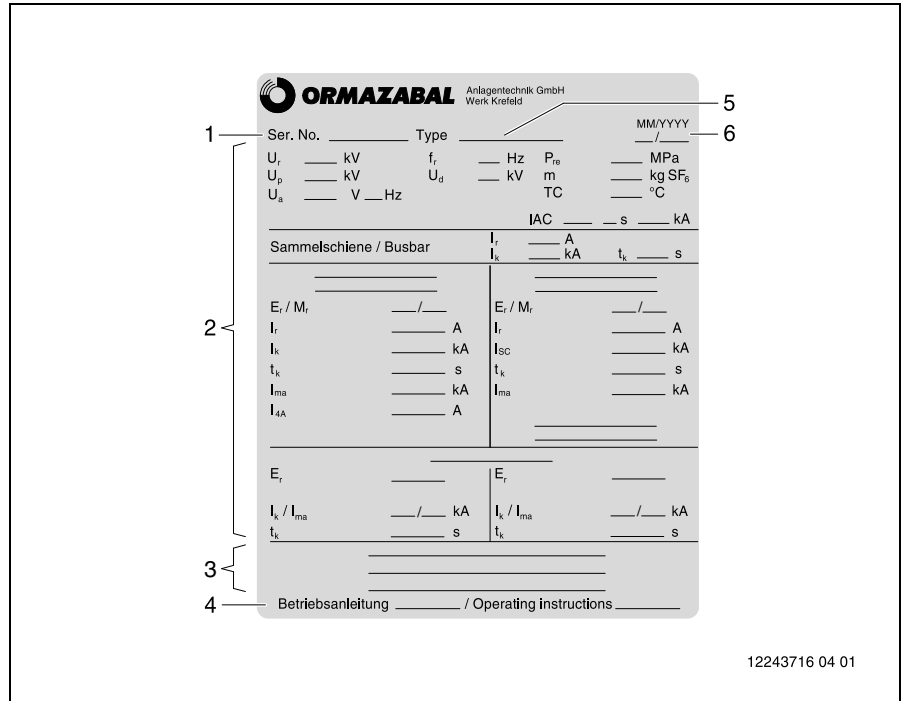

Fig. 6 Rating plate (example)

- 1 Serial number
- 2 Technical data
- 3 Standards applied
- 4 Document numbers of the corresponding operating instructions (German/English)
- 5 Type of unit
- 6 Manufacturing date: month/year

### 3.5 Installation and assembly

To install the circuit-breaker panel, use the installation plan shown in Chapter 3.6.1. In order to assure secure standing of the circuit-breaker panel use all fastening bores provided.

The depths of the individual panel types in the GAE family vary.

In order to ensure all possible block/panel combinations (excluding LSF-panels) can be installed, the foundation projection must be drawn at a distance of 135 mm from the wall!

In the case of the installation of LSF-panels, a minimum distance of 200 mm is necessary.

On the variant with pressure absorber channel the minimum distance is 100 mm.

#### Note!

If it is certain that during a system extension no:

- GAE630 -1LSFxx- panels
- GAE measuring panels with metal cooling stretch are installed, the distance from the wall can be reduced to 100 mm.

To ease the assembly of the modular switchgear GAE630, we recommend the following distances from side walls on installation from left to right:

- Distance from left wall at least 100 mm
- right wall distance at least 300 mm.

When installing from right to left the lateral wall distances are reversed.



The area for the floor opening must not be reduced in size, so that, in case of an arc incident, the hot gases can be safely discharged.

A straight and level floor surface is a prerequisite for the stress-free installation of the earthing panel. Pay attention to the information in DIN 43661. In particular the tolerance on the evenness (maximum 1 mm over a measured length of 1 m) and the tolerance on the straightness (maximum 1 mm per metre and maximum 2 mm over the entire length of the foundation rail) are to be observed.

#### Note!

To ease the assembly work on the installation of several GAE panels, we recommend the usage of a metal chassis.

The fastening material is not part of the delivery.

To fastening the earthing panel to a raised floor, we recommend the following fastening material:

- Hexagon screw M10 (minimum M8, strength class 5.6) DIN EN ISO 4017
- Washers DIN EN ISO 7093 (switch panel side)
- Washers DIN EN ISO 7089/7090 (raised floor side) or tapered washers for fastening to U-sections
- Spring lock ring DIN 127 / DIN 128
- Hexagon nut M10 DIN EN ISO 4032

In the case of installation on concrete with a strength of  $B \geq 25 \text{ N/mm}^2$ , we recommend the following fastening material:

- Fischer plastic dowels of type S12
- Wood screw DIN 571-10x80-St
- Washer DIN 125 A10

To make the fastening bores accessible for installation, remove the front cover (see Chapter 5).

### 3.6 Planning of installation

#### 3.6.1 Floor fastening measurements

Fig. 7 shows the floor fastening and floor opening measurements for pressure relief in the cable trench/raised floor.

**Note!**

The standard circuit-breaker panel is shown at the left-hand side of Fig. 7, the right-hand side shows the panel fitted with a deeper front cover (optional)

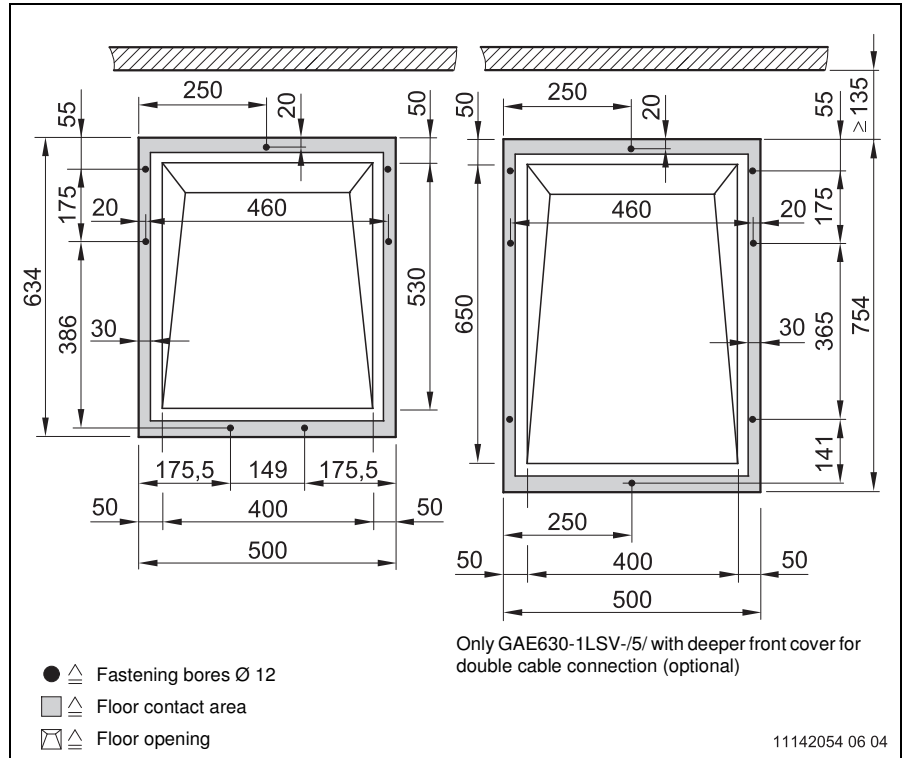

Fig. 7 (Dimensions in mm)

Fig. 8 shows the floor fastening and floor opening measurements for a pressure relief via the rear pressure absorber channel into the switchgear room.

**Note!**

The standard circuit-breaker panel is shown at the left-hand side of Fig. 8, the right-hand side shows the panel fitted with a deeper front cover (optional)

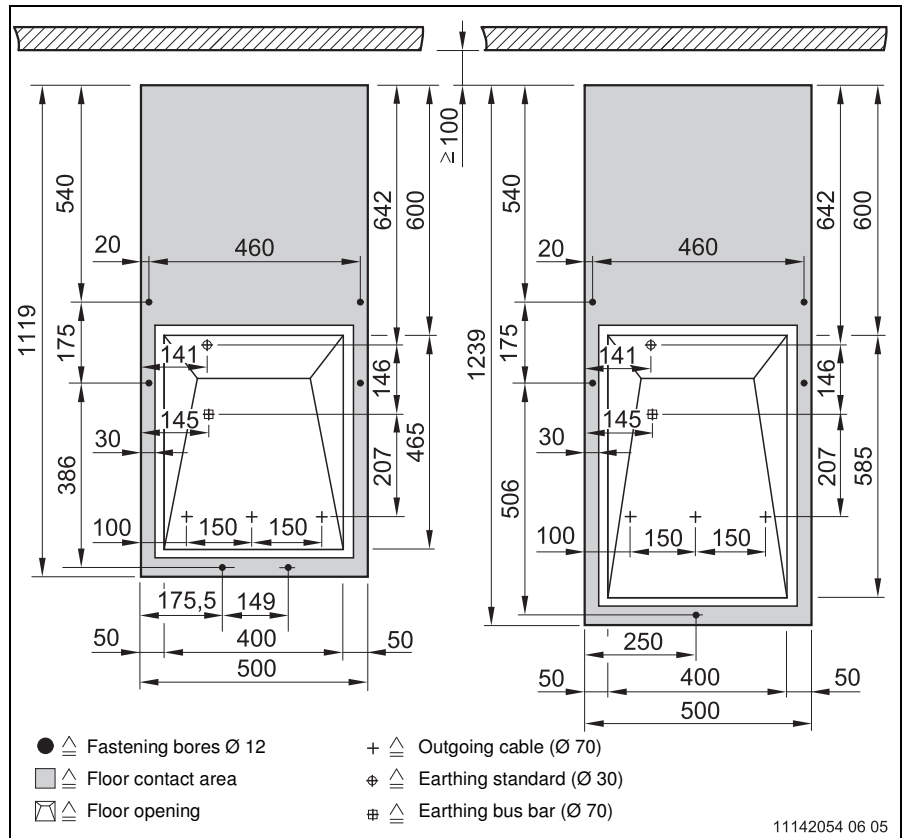

Fig. 8 (Dimensions in mm)

### 3.6.2 Dimensions

The circuit-breaker panel GAE630 -1LSV630- is supplied in the following designs:

- Type GAE630 -1LSV630- standard circuit-breaker panel
- Type GAE630 -1LSVG630- bus sectionaliser circuit-breaker panel

The dimensions of the circuit-breaker panel GAE630 -1LSV630 are shown in Fig. 9.

Additional panel equipment (transformers, relays, etc.) is fitted to customer-specific requirements. Their handling and main attributes can be found in the following, customer-specific plans and additional documents:

- Installation plans
- Overview plans
- Equipment list
- Equipment plans
- Control plans
- Telecommunication plans
- Connection plans.

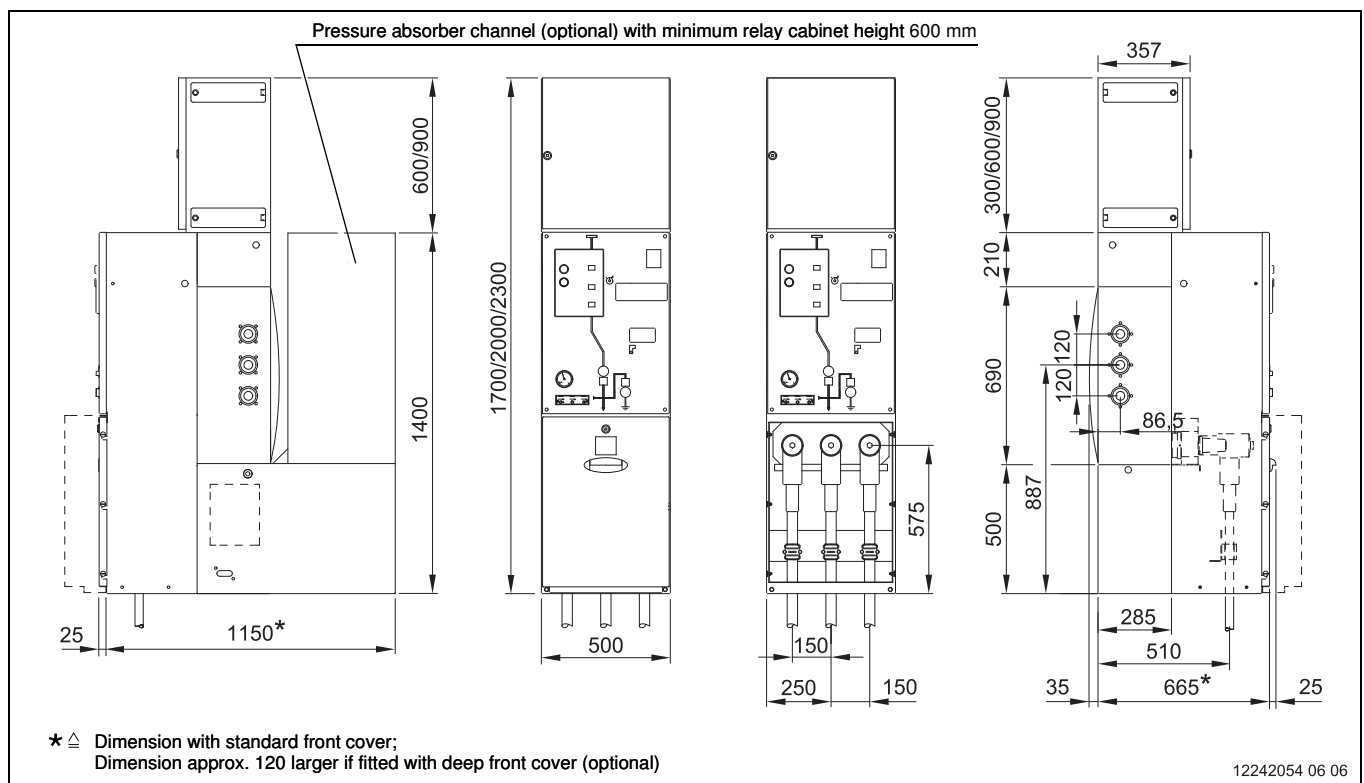

Fig. 9

**3.6.3 Possible installations**

**Installation possibility for circuit-breaker panels in accessible switchgear rooms.**

**Attention!**

During installation make sure not to damage the burst protection in the bottom of the gas tank (Fig. 10). This diaphragm opens in case of an internal arc fault. The gases emerging must be discharged as shown in Fig. 10.

As shown in Fig. 10 the cable trench must have a defined minimum cross section. For the optional pressure relief of the cable trench the following rule of thumb must be applied:

- up to 3 panels: 1 metal cooling stretch arrangement (400 x 600 mm)
- from 4 panels: 1 second metal cooling stretch arrangement of the same size.

The metal cooling stretch arrangement provided by the customer must be arranged in a way that the cable trench is evenly divided.

In order to enhance the stability the rear wall of the circuit-breaker panel can be fastened with two steel angles (not included in the scope of delivery). For this purpose use the screw connections from the transport device.

Please ask for our assistance in the planning and installation of the station.

The construction of the building and the switchgear room must withstand the expected mechanical loads and the internal pressure caused by a short-circuit arc. Corresponding calculations for this are recommended.

Switchgear related pressure calculations can be requested as part of the services provided by the sales department at Ormazabal GmbH.

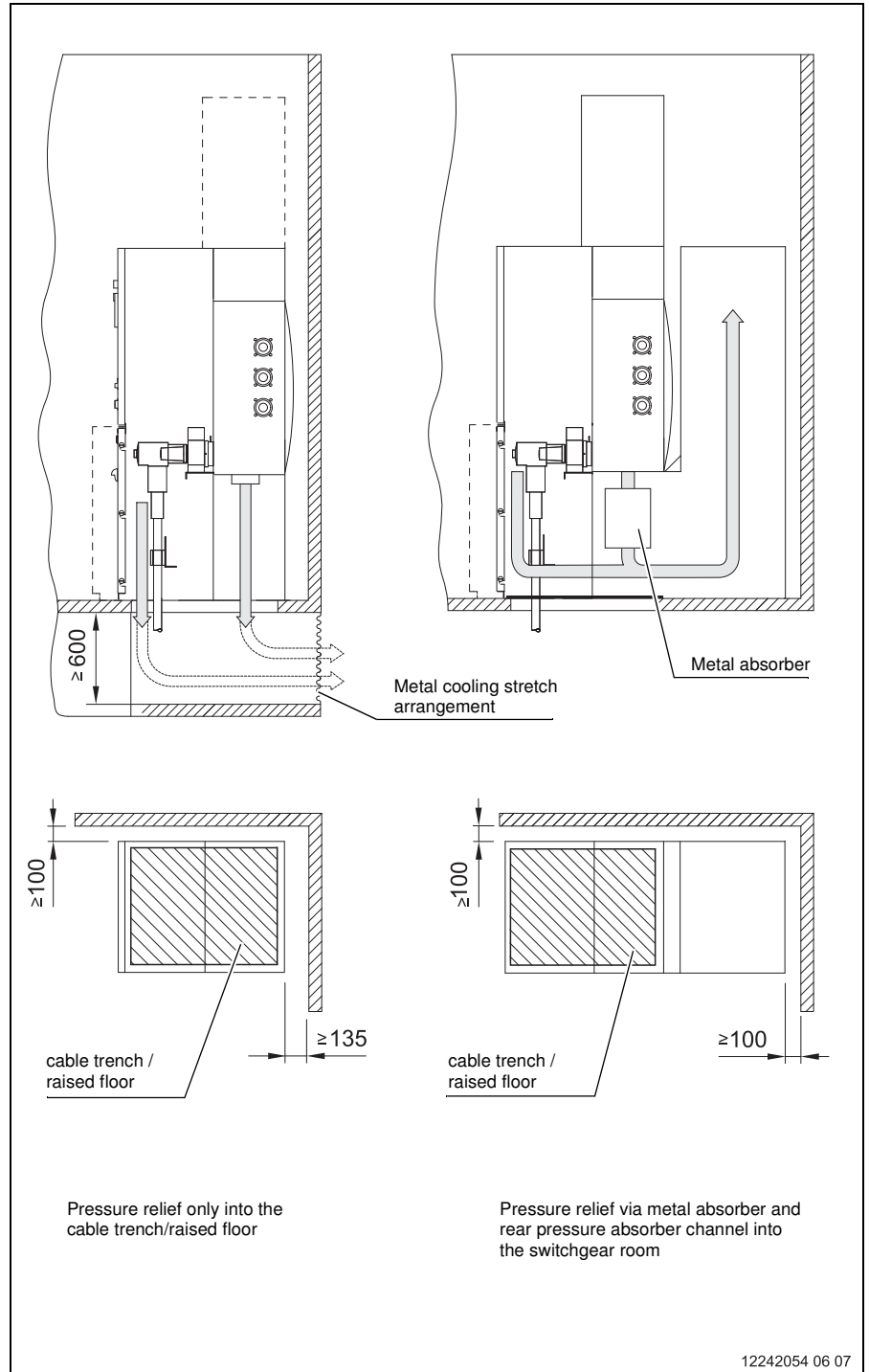

Fig. 10

### 3.7 Installation of the supply line for the auxiliary and control circuits

There are openings for laying the supply line for the auxiliary and control circuits in the roof of the relay cabinet.

Flexible plugs are fitted in these openings, which provide a cable bushing protected against dust and moisture. For adaptation to the cable diameter use the separating lines on the plugs.

The supply line from a neighbouring panel on the left or right (loop cable) is laid through openings in the related side wall on the relay cabinet (Fig. 11).

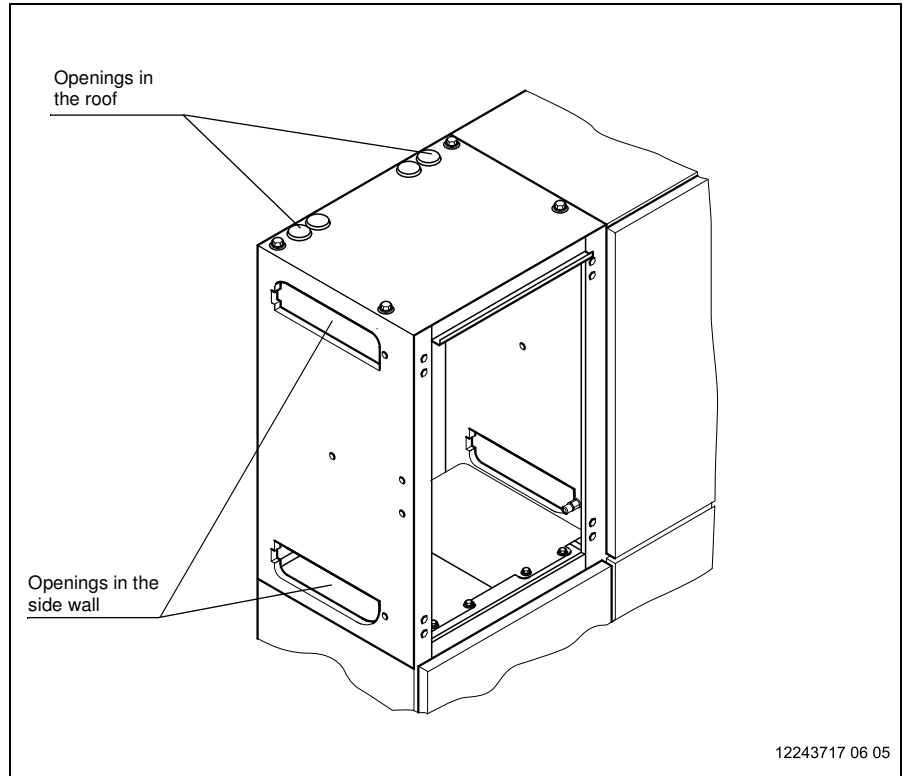

Fig. 11 Relay cabinet flush at the rear wall

If the relay cabinet on the neighbouring panel is fitted offset, the cable can be laid through the openings in the roof of the relay cabinet (Fig. 12).

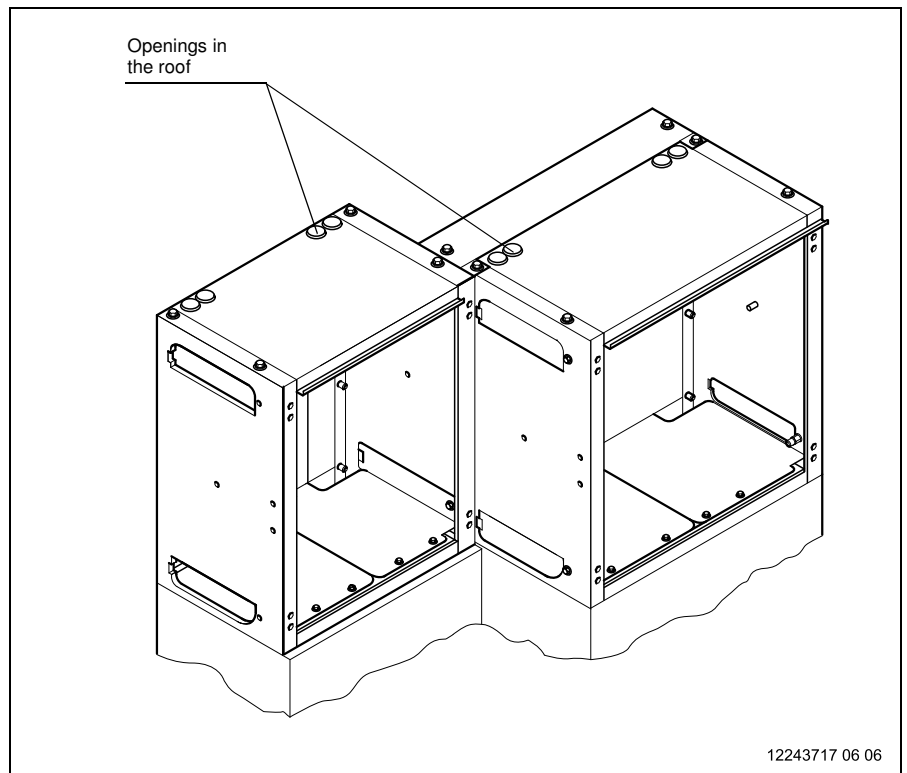

Fig. 12 Relay cabinet offset

### 3.8 Connection of the power cables

Please proceed as follows to connect the power cables:

- Remove the front cover (see Chapter 5, "Operation").
- Only on variants with bottom plates: Remove the front bottom plate and the rubber cable grommets. Push the rubber cable grommets onto the power cables to be connected.
- Route the power cables through the floor opening, cut to length, put in place and mount the male cable connector or adapter by following the instructions of the respective manufacturer.
- Only on variants with bottom plates: Insert the power cables with the rubber cable grommets into the cut-outs in the rear bottom plate.
- Connect power cables to the panel.
- Fix power cables to the cable fixing iron using the cable clamps so they are free of strain.
- Connect the earthing cables to the earthing terminals of the cable fixing iron.

**Note!**

If the circuit-breaker panel is fitted with window-type current transformers you must route the earthing cable through the transformer and then to the earthing terminal of the cable fixing iron.

- Only on variants with bottom plates: Re-fit the front bottom plate. During this process ensure the rubber cable grommet is correctly inserted between the bottom plates.

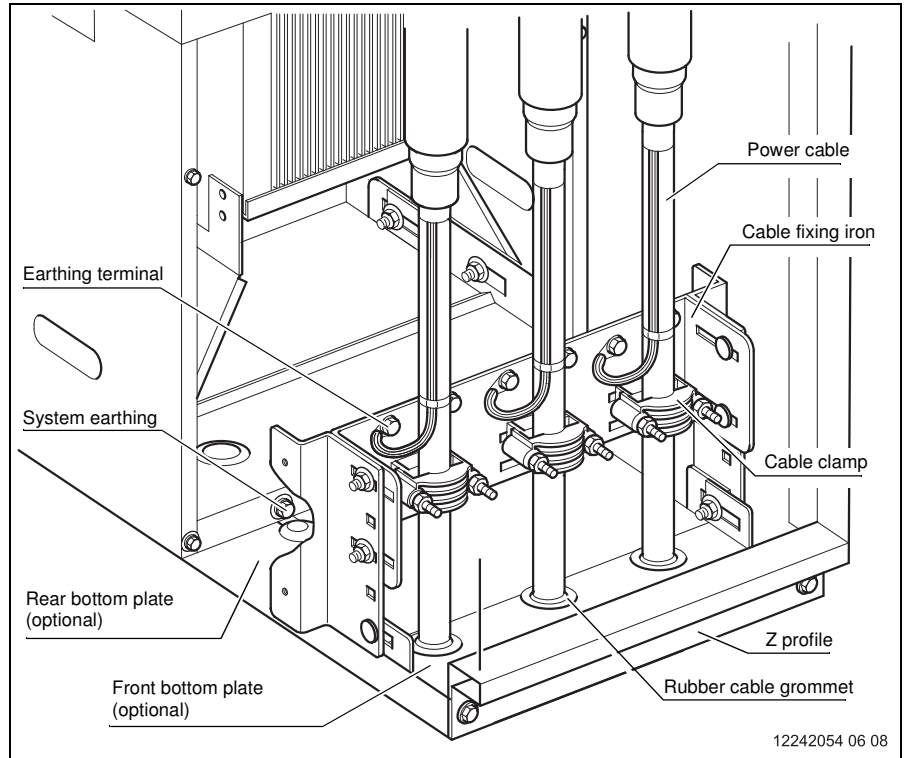

Fig. 13

### 3.9 Attachments

The auxiliary switches for the disconnecter and earthing switch are behind the control panel cover on the right-hand side of the panel (Fig. 15).

Fig. 16 shows the connection diagram (standard version) for the auxiliary switches.

For additional relevant information on the wiring of the circuit-breaker panel, please refer to the enclosed circuit documentation.

If additional auxiliary circuits are to be laid from the cable connection compartment or the drive compartment, proceed as follows:

- Remove the control panel cover. Do this by removing the 4 securing screws and lift the control panel cover off the circuit-breaker panel (Fig. 14).

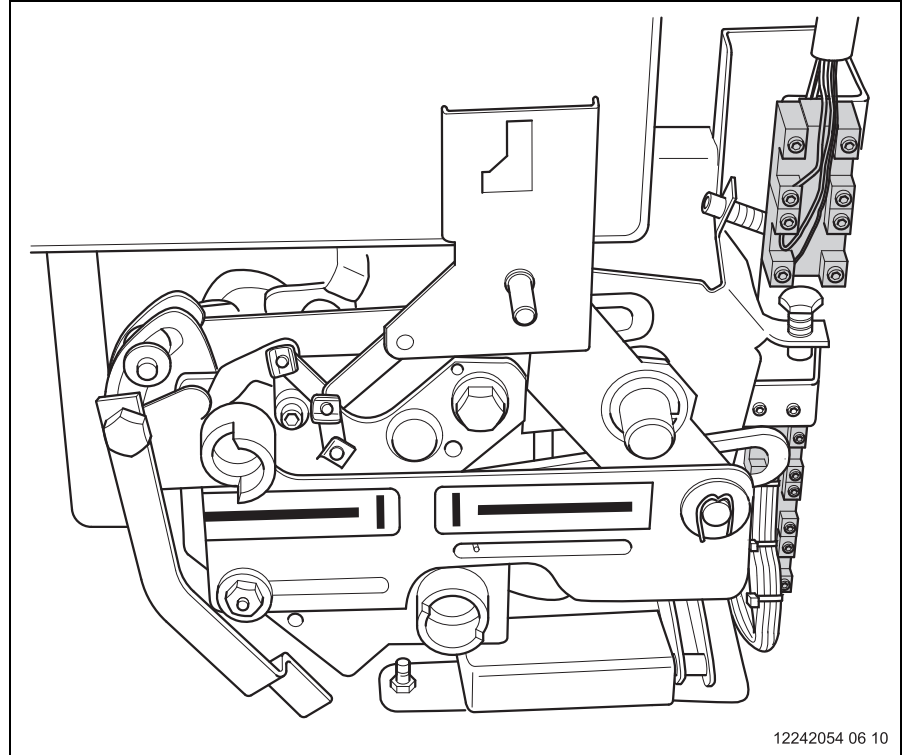

Fig. 15

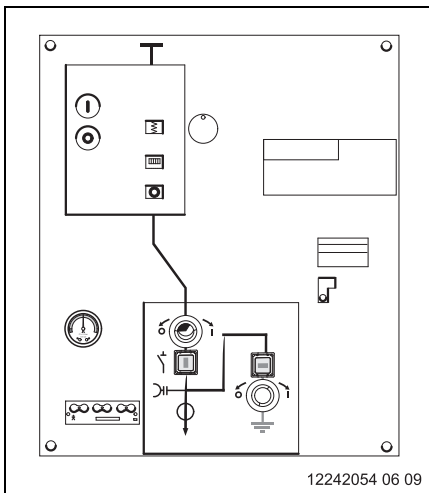

Fig. 14

- Remove the bottom plate from the relay cabinet. Do this by disconnecting the screw connections on the left- or right-hand bottom plate and remove the plate.

Assembly of bottom plate and control panel cover is performed in reverse order.

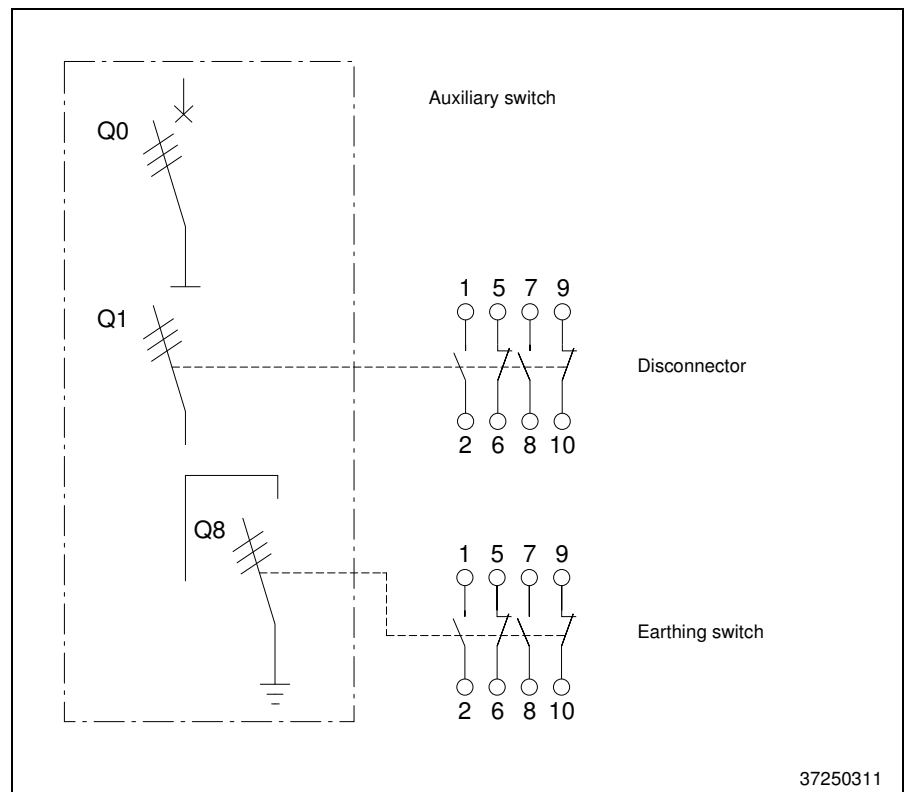

Fig. 16

### 3.10 Earthing

The circuit-breaker panel must be earthed in accordance with DIN VDE 0141/0101.

The GAE630 circuit-breaker panel is fitted with an earthing rail, which runs across the whole width of the base of the panel

As a measure to ensure an electrically conductive connection of the metal enclosure, earthing rail and enclosure are bolted with contact washers. This makes sure that, in case of a ground leak or a double ground leak, the fault currents are safely discharged to the earth connection.

The earthing rail is equipped with a screw connection (M12) for the connection of an earthing line to establish earthing of the unit (Fig. 17).

The earthing points on the cable fixing iron are occupied by the cable lugs of the cable screens. The cable fixing iron is designed with additional, freely assignable earthing terminals.

To simplify assembly, the earthing points are provided with M10 riveting nuts.

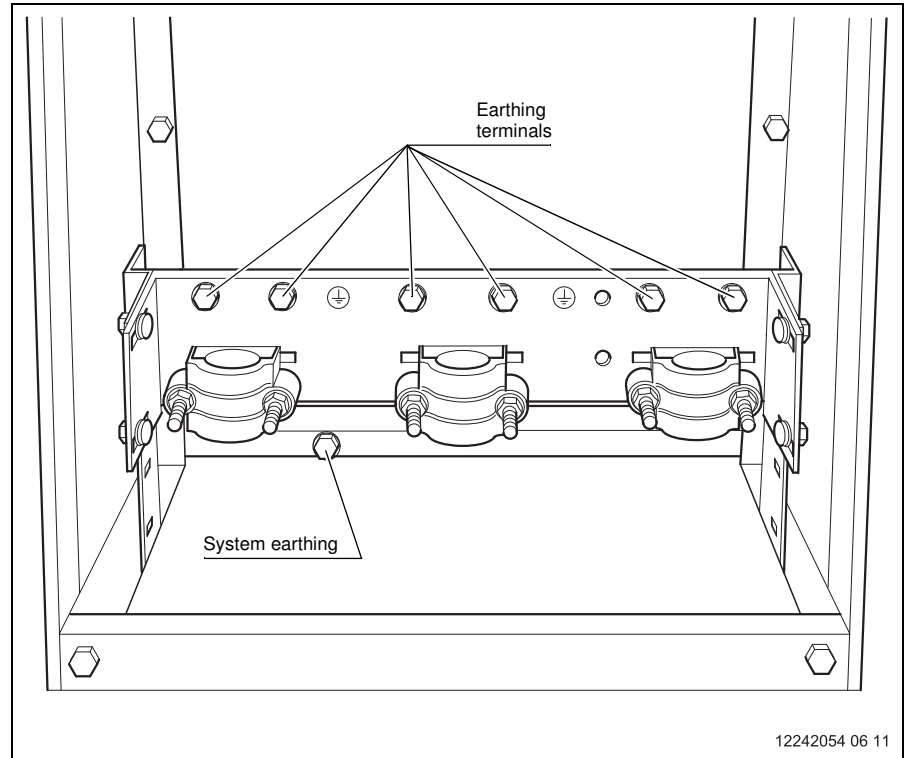

Fig. 17

## 4 Technical description

### 4.1 Circuit-breaker panel

The GAE630 -1LSV630- circuit-breaker panel is a quality product manufactured to the requirements of DIN ISO 9001. It can be used for a rated voltage of up to 24 kV and a rated normal current of 630 A and has the following features:

- metal-enclosed
- low maintenance (HV compartment, maintenance-free gas tank)
- type-tested
- extendable through side busbar connections.

The GAE630 circuit-breaker panel comprises the driving mechanism for circuit breakers and three-position switches, the gas tank with vacuum circuit breaker (type GNVL), the three-position switch (disconnecter and earthing switch), the busbars and cable connection compartment.

During production, a functional module, comprising a vacuum circuit-breaker, three-position switch, switch drive mechanism and interlocking of circuit-breaker and disconnecter is assembled as a pre-tested unit on the front wall of the tank and is subsequently gas-tightly welded to the stainless steel tank.

Sulphur hexafluoride (SF<sub>6</sub>) is used as an insulating medium.

The circuit-breaker panel's operating and indication elements are clearly arranged on the control panel cover (see System Overview, Fig. 1).

The circuit-breaker elements are fitted to the upper part of the cover and those for the disconnecter and earthing switch are fitted to the lower part

The symbols relevant to the earthing circuit are in red, those for the main current path are in black.

#### 4.2 Extension of the circuit-breaker panel

The circuit-breaker panel GAE630 -1LSV630- can be extended using GAE family panels and block modules. Extensions are usually added to the right. The design of the complete switchgear is oriented to the customer's requirements.

The busbars of the complete switchgear are phase separated and arranged vertically above each other in the gas tank. The busbars of the panels to be attached are connected by means of contact bolts, which are inserted with double seals into the lateral bushings.

The panels to be attached are laterally connected at two panel screw connection points.

During the installation of the circuit-breaker panel as an end panel, the side bushings must be secured with sealing ends to maintain the dielectric strength of the switchgear (Fig. 19). The screw plug is to be fitted in the bottom panel screw connection point.

GAE630 -1LSV630- end panels can be delivered with pre-assembled sealing ends on the lateral bushings.

**Attention!**

To attach GAE630 panels and block modules and to assemble end panels, follow the assembly instructions "Panel screw connection for extensible GAE630 panels", article no. 12244002.

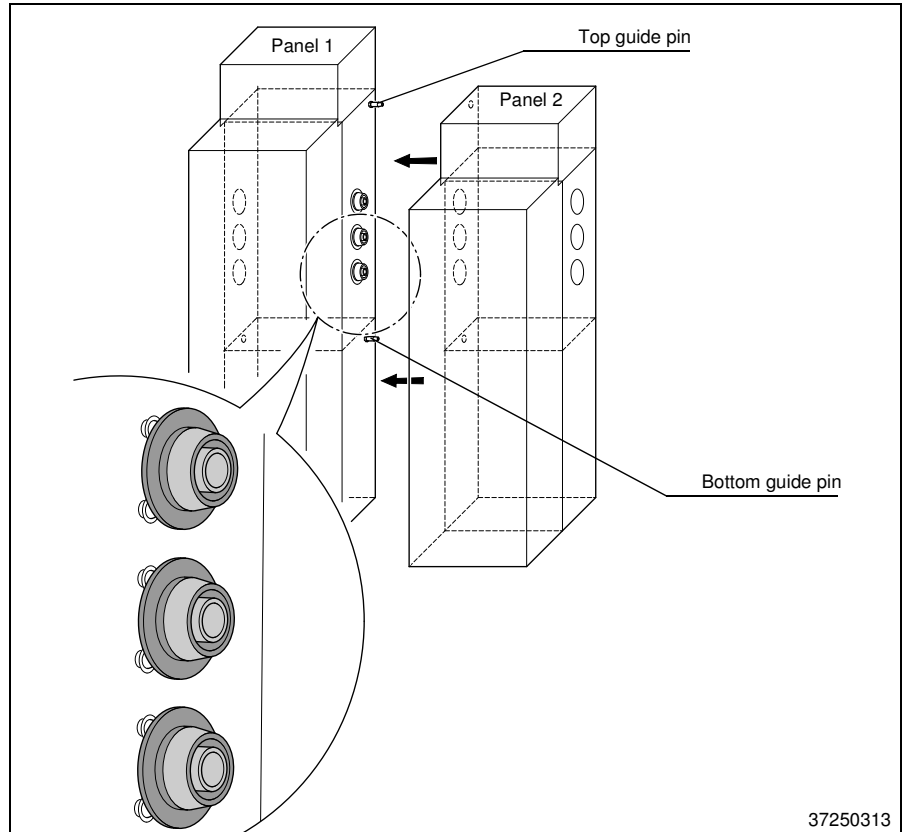

Fig. 18

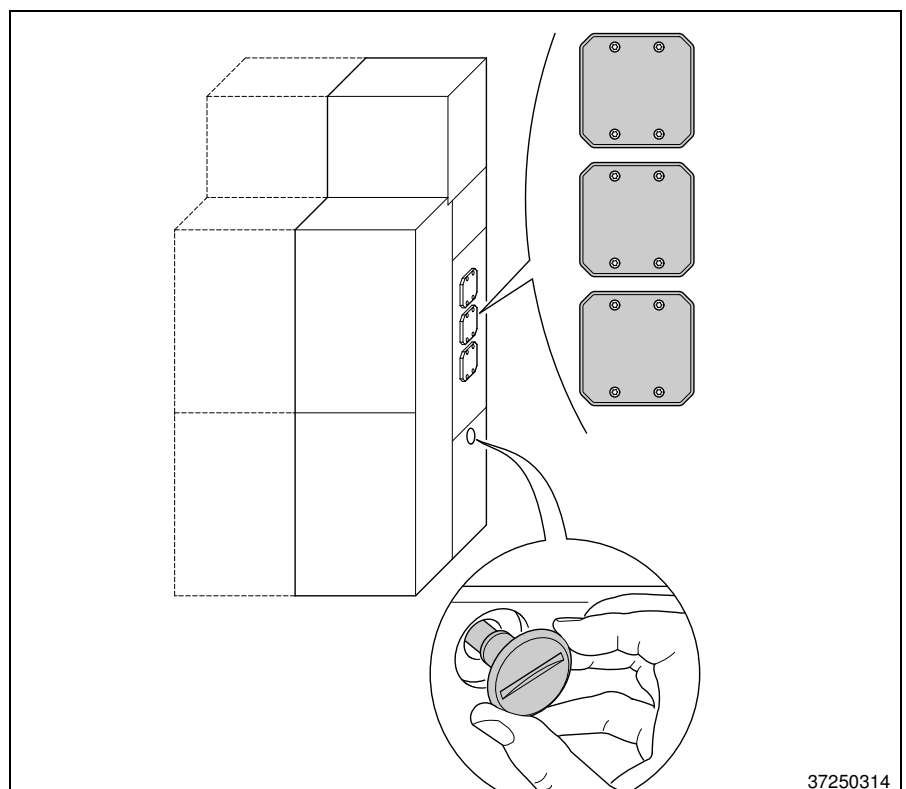

Fig. 19

#### 4.3 Gas tank

The gas tank is made of stainless steel. A prerequisite to the safe function of the switchgear over many years of service is guaranteed by optimum production of the mechanical parts and leak tightness of the tank

The gas-tightly welded tank is checked for leaks in accordance with IEC 62271-200 (permissible leakage rate  $10^{-7}$  mbar x l/s).

The gas tank contains the vacuum circuit breaker, which is connected in series with the three-position switch. The bushings for the busbars are located on the side of the tank and are connected to the vacuum circuit-breaker inside the tank by means of copper busbars. The three-position switch also connects the cable bushings to the circuit-breaker by means of copper busbars.

The power cables are connected to resin bushings with outer taper in accordance with DIN 47636 Parts 1 and 3.

The bushings are checked for compliance with the maximum permissible partial discharge values.

Bushings, sealing flange for actuating shaft and bursting plate are sealed towards the tank by means of sealing rings. The three-position switch's actuating shaft is fitted to the tank with twin paired radial shaft seals. The force is transmitted to the circuit-breaker by way of a pre-tensioned sealing membrane, which moves between the two operating points "ON" and "OFF".

The tank in each circuit-breaker panel is charged with dry SF<sub>6</sub> gas after evacuation. The addition of Al<sub>2</sub>O<sub>3</sub> absorbs the slightest amount of moisture and continually regenerates the SF<sub>6</sub> gas.

#### 4.4 Gas leakage indicator

The gas pressure is indicated by an aneroid diaphragm pressure gauge, which is connected to the tank via a check valve. The aneroid diaphragm pressure gauge is corrosion-resistant.

The indication range (Fig. 20) is divided into two measuring ranges.

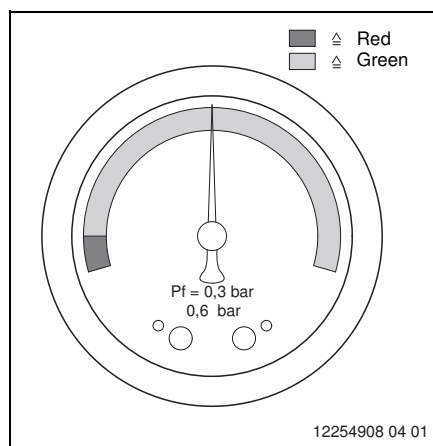
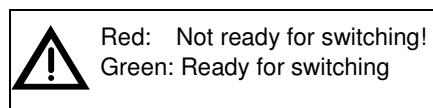

Fig. 20



Before each switching process the gas filling inside the tank must be checked on the gas leakage indicator.

#### 4.5 Pressure switch/density monitor (optional)

For remote monitoring the switchgear can optionally be equipped with a density monitor, which works as a normally closed contact in the auxiliary circuit.

The bottom switching point of the density monitor or pressure switch is 106 kPa abs. If the pressure in the gas tank drops to 106 kPa abs., the density monitor or pressure switch will report this pressure drop.

The bottom switching point of the density monitor or pressure switch corresponds with the transition to the red measuring range on the scale of the gas leakage indicator. The density monitor or pressure switch is fastened to the non-return valve, together with the gas leakage indicator.

#### 4.6 Vacuum circuit-breaker

The vacuum circuit-breaker is a three-pole, indoor circuit-breaker with rated voltages of 12 kV or 24 kV.

It comprises the base frame, to which the actuator and pole part are fitted.

The switch poles take up the vacuum switch tubes with contact system, the contact pressure spring and the opening spring.

The following circuit-breakers are used:

- **GNVL 24/16/630-1** (gas insulated Vacuum circuit-breaker with motor winding).
- **GNVL 24/16/630-1/H** (gas insulated Vacuum circuit-breaker with manual winding).

The operating mechanism is a stored energy spring mechanism. It is connected to the vacuum contact chambers via a system of levers and a gas-tight membrane.

The stored energy spring mechanism is tensioned by using a crank handle or winding motor. The circuit-breaker can be tripped manually by means of a pushbutton or electrically by means of an actuator.

When switched ON, the closing spring relaxes and closes the contacts in the vacuum chamber via a series of levers. The opening spring is simultaneously tensioned. Re-tensioning the closing springs immediately after switching the circuit-breaker ON allows makes it possible to switch a brief interruption OFF-ON-OFF.

The standard circuit-breaker is always equipped with the ON and OFF pushbutton, the switch position indicator, the spring accumulator indicator and the operating cycles counter.

The basic equipment for controlling and triggering the circuit-breaker with manual wind-up comprises the following auxiliary units:

- transformer-operated trip Y5
- four-pole auxiliary switch for messaging purposes
- fleeting contact, message OFF.

Fig. 21 shows the circuit diagram of the GNVL circuit-breaker with the maximum possible extras in the OFF position, with relaxed spring accumulator. The order-specific extras for the respective order can be found in the circuit diagrams provided.

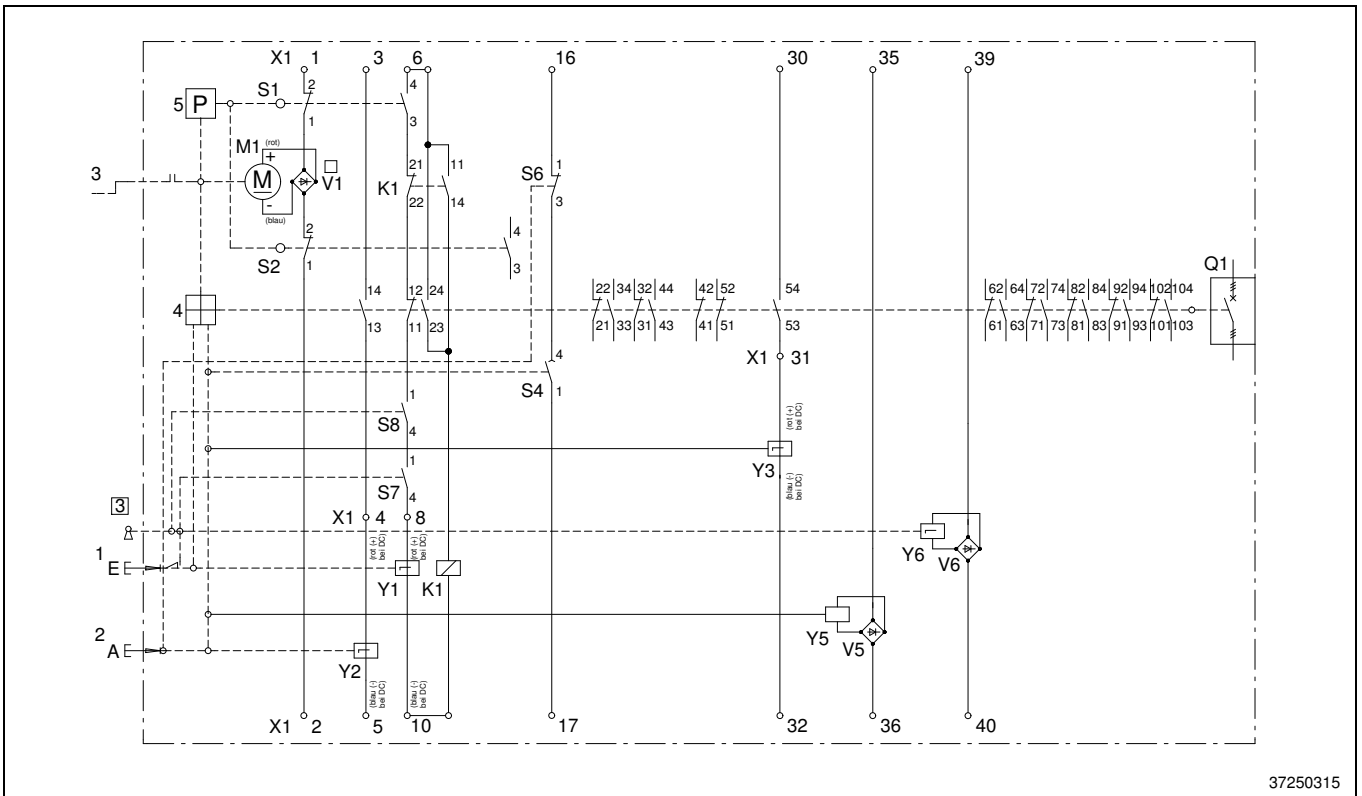

Fig. 21

- |    |   |    |  |
|----|---|----|--|
| Q1 | Circuit-breaker with 20-pole auxiliary switch | S1 | Control switch (ON release and motor) and motor)               |
| M1 | Winding motor                                 | S2 | Control switch (stored energy spring mechanism)                |
| X1 | Terminal block                                | S4 | Fleeting contact, signal OFF                                   |
| K1 | Anti-pumping relay                            | S6 | Fleeting contact break for S4                                  |
| Y1 | Shunt release "ON"                            | S7 | Make contact to release the interlock for electrical switch-ON |
| Y2 | Shunt release "OFF 1"                         | S8 | Make contact to interlock electrical switch-ON                 |
| Y3 | Shunt release "OFF 2"                         | Y5 | Transformer-operated trip                                      |
| Y6 | Closing lock-out                              | V5 | Rectifier for Y5   |
| V1 | Rectifier for motor                           |    |  |
| V2 | Rectifier for blocking magnet                 |    |  |

**Note!**

Further information can be found in the operating instructions provided for the respective vacuum circuit-breaker.

#### 4.7 Three-position switch

The disconnecter and earthing switch is a three-position switch. Its schematic design can be seen in Fig. 22.

The technical design of the three-position switch is simple and reliable. The switching positions ON-OFF-EARTHED can be switched with only one switching element (pair of switching blades).

Each pair of switching blades is borne on a support and connected to the earthing contacts of the switching shaft by a coupling rod. The fixed device contacts are connected to the circuit-breaker by means of copper conductors. The pair of switching blades for each phase slide to the corresponding contact, depending upon the switch position.

In order to guarantee a long service life for the switching elements, the blades and contact elements are made of arc-resistant, low-wear material. Due to their design, the switching blades' contact rivets have a dry lubrication effect and prevent the blades from being welded to the contacts if a short circuit occurs.

#### 4.8 Three-position switch drive

The spring drive switches the disconnecter and the earthing switch.

The drive is borne on a U-shaped drive carrier. The robust spring drive is equipped with both disconnecter and earthing actuating shafts.

Both actuating shafts are hollow shafts with integrated blade inhibitor. These inhibitors prevent the blades from swinging through to the opposing contact of the three-position switch when switching the disconnecter or earthing switch OFF. They are unlocked when the switching lever is inserted into the actuating shafts.

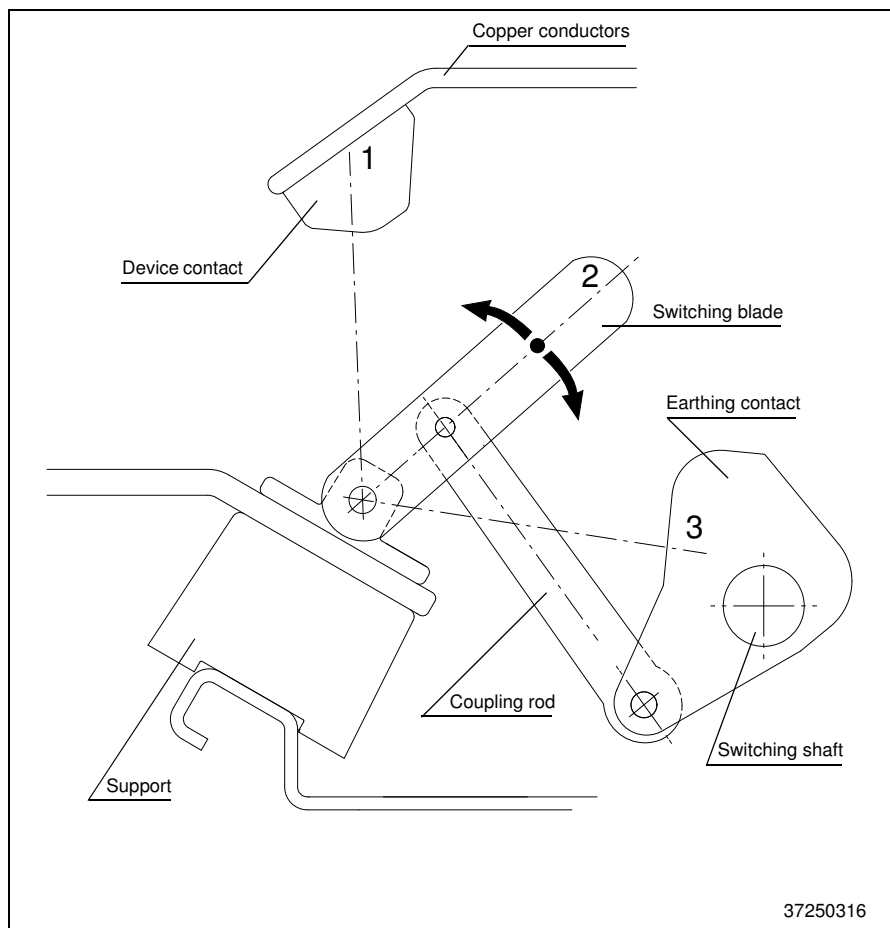

Fig. 22

Function and layout of the actuating shafts can be seen in the mimic diagram.

The rotary movement of the actuating shafts is transferred to the switching shaft via toggle links and the operating lever.

The switch position indicator is controlled by the operating lever.

All parts of the drive susceptible to corrosion are galvanised.

#### 4.9 Switch panel interlocks

The circuit-breaker panel GAE630 -1LSV630- are provided with the following interlocks as standard fittings.

- Earthing switch to front cover (front cover interlock)
- Circuit-breaker to disconnector or earthing switch respectively
- Disconnecter to earthing switch

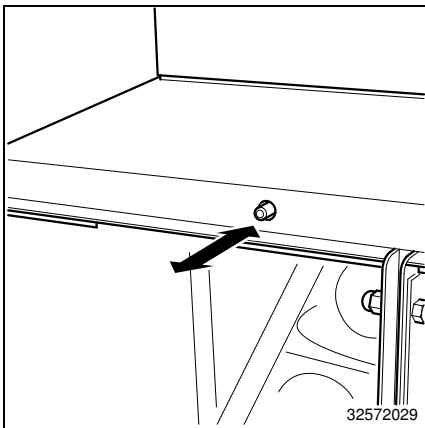

Fig. 23

The front cover interlock (Fig. 23) ensures that the front cover can only be removed, when the earthing switch has been operated. When the earthing switch is switched OFF, a bolt engages in a recess in the front cover, thus locking it.

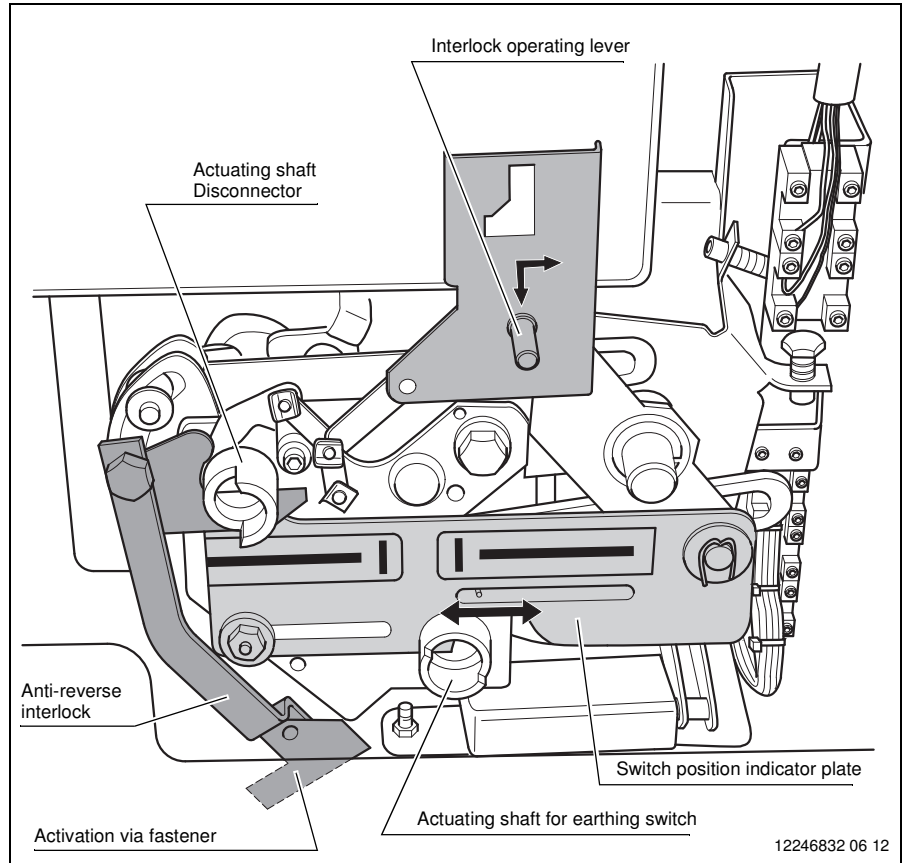

Fig. 24

The interlock between the circuit-breaker and the disconnector or earthing switch (Fig. 24) is effected with the aid of the operating lever. It can only be changed, when the circuit-breaker is switched OFF. Whereby the switch positions of the disconnector or earthing switch are immaterial.

The interlock between the disconnector and the earthing switch (Fig. 24) is effected by the switch position indicator. This closes off the plug-in opening for the switching lever on the corresponding switching shaft.

An anti-reverse interlock (Fig. 24) is available upon request.

This prevents the disconnector from being switched ON when the front cover has been removed. The anti-reverse interlock is switched ON or OFF by the fastener key.

When the fastener is open, the plug-in opening for the switching lever on the disconnector switching shaft is closed off by a plate.

With the front panel removed the earthing switch can be switched off in order to check the cables.

#### 4.10 Current transformer

Low voltage toroidal transformers and spectacle-shaped core transformers in accordance with IEC 600441-1 and VDE 0414 Part 1 are used around the extended outer taper bushings in the outgoing panel and the transition panel of circuit-breaker panels.

The protection and optional measurement cores are integrated into a common transformer block.

The current transformers are optionally provided with an calibratable or calibrated measurement core.

It is possible to remove or replace the current transformers simply, without opening the gas tank. It is also possible to use window type current transformers that are fitted around the earthed cable sheath of the conductor cables in the cable duct.

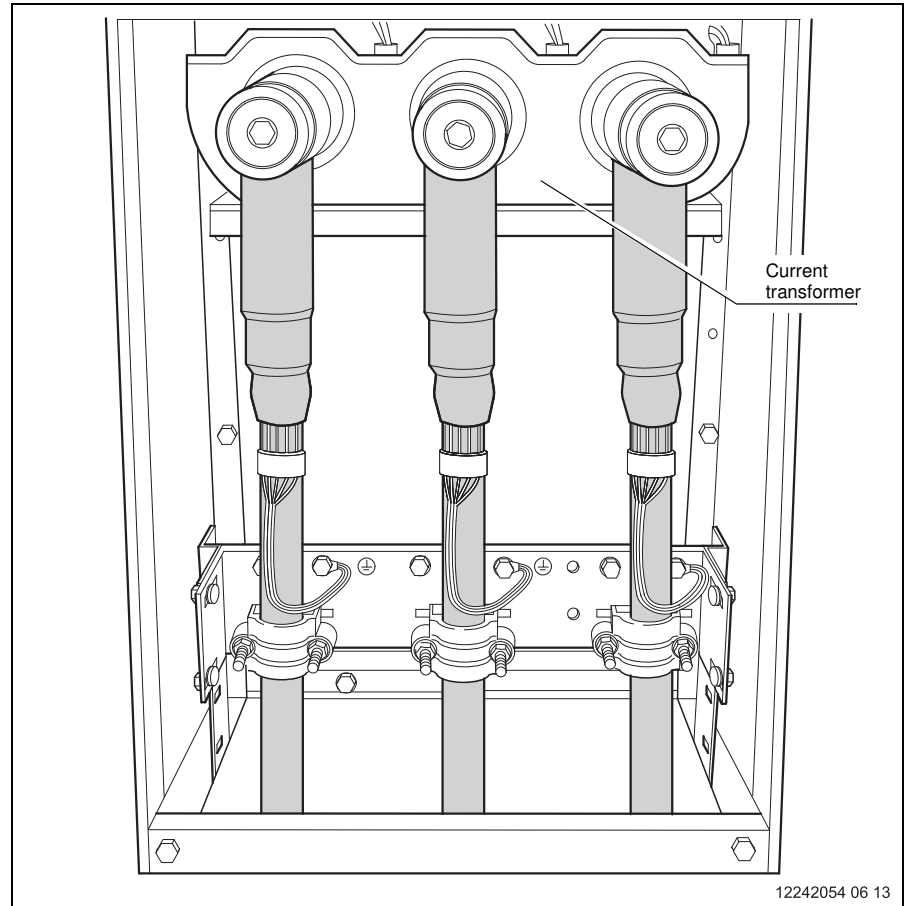

Fig. 25

#### 4.11 Capacitive voltage detecting system

For detection of the de-energised state, each panel section is fitted with a capacitive coupling element (voltage indication ledge, Fig. 26) in the control panel cover.

It is a HR-system acc. to VDE 0682, part 415 and IEC 61243-5.

The voltage indication ledge consists of a insulated housing with all electronic assembly parts encapsulated.

The test sockets integrated into the voltage indication ledge make it possible to connect commercially available HR voltage testers.

The coupling part must be subjected a repeat test at regular intervals (approx. every 6 years). This test must be performed at the operational voltage using appropriate test units or adapters.

Captive shrouds protect the test sockets against dirt, dust and moisture (Fig. 26). For voltage testing they must be swivelled by 90°.

The test must be performed with an appropriate voltage tester (Table 1) (Fig. 27).

Pfisterer	Type DSA-2
Horstmann	Type HO-ST-1
ELSIC	Type HO-SA
Jordan	Type DSP-HR
Dehn	Type Dehn cap/P-HR

Table 1

With a flashing indicator these units indicate that voltage is applied to the testing point of the bushing.



During each switching process (connection to or disconnection from the mains) the function of the capacitive voltage detecting system must be checked, if a de-energised state is detected (see Chap. 6.5). Always check all phases  
L1, L2, L3!

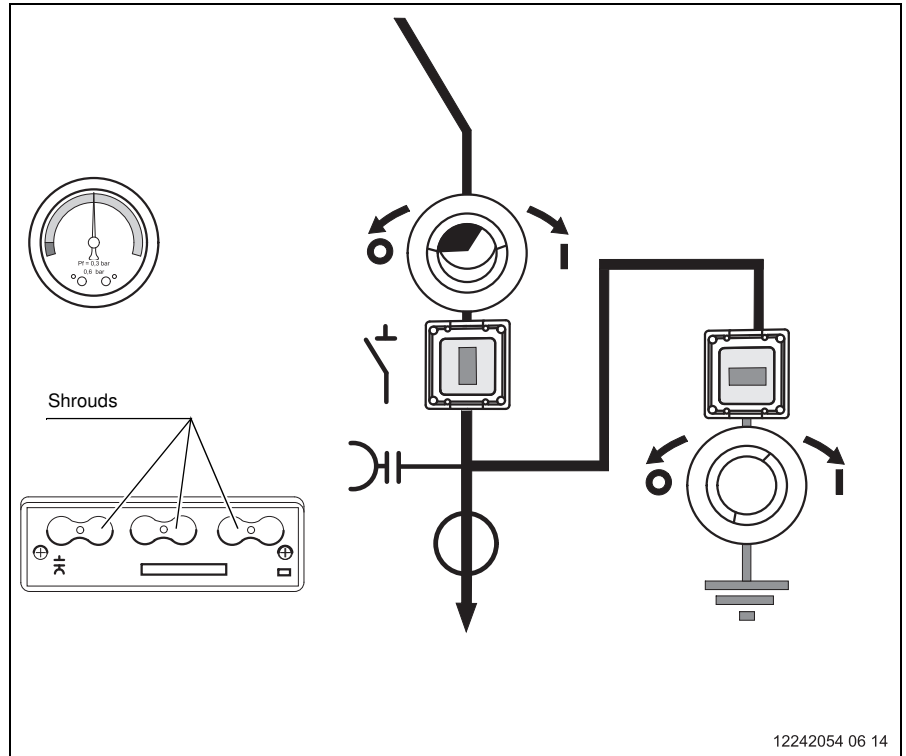

Fig. 26

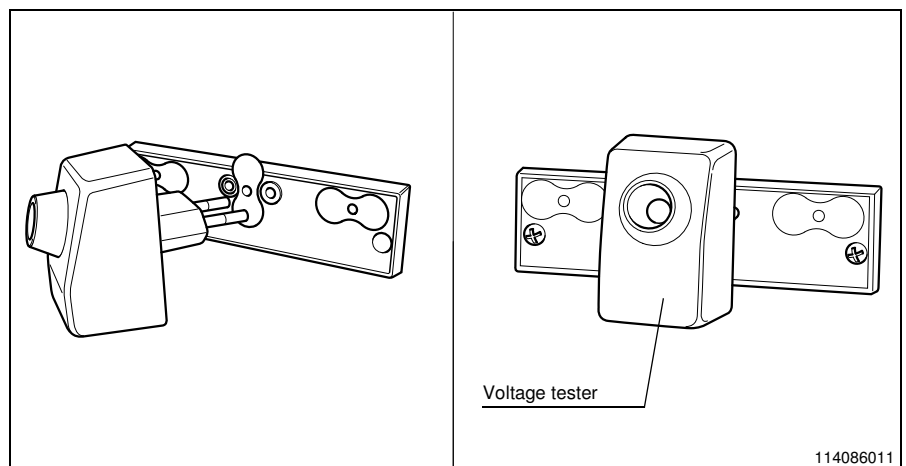

Fig. 27

A capacitive voltage indicator with continuous triple phase indication and permanent self-monitoring can be used as an option.

This device indicates that there is a voltage present at the test point on the capacitive insulating support by displaying flashing lightning arrows on the integrated display.

No additional voltage indicating devices and no repeat tests are necessary.

In addition, the device has an integrated triple phase measuring point. This device is calibrated in accordance with LR requirements as per VDE 0682 part 415 and IEC 61243-5 and is suitable for phase testing using an LR-phase comparator.

A captive shroud protects the test sockets against dirt, dust and moisture.

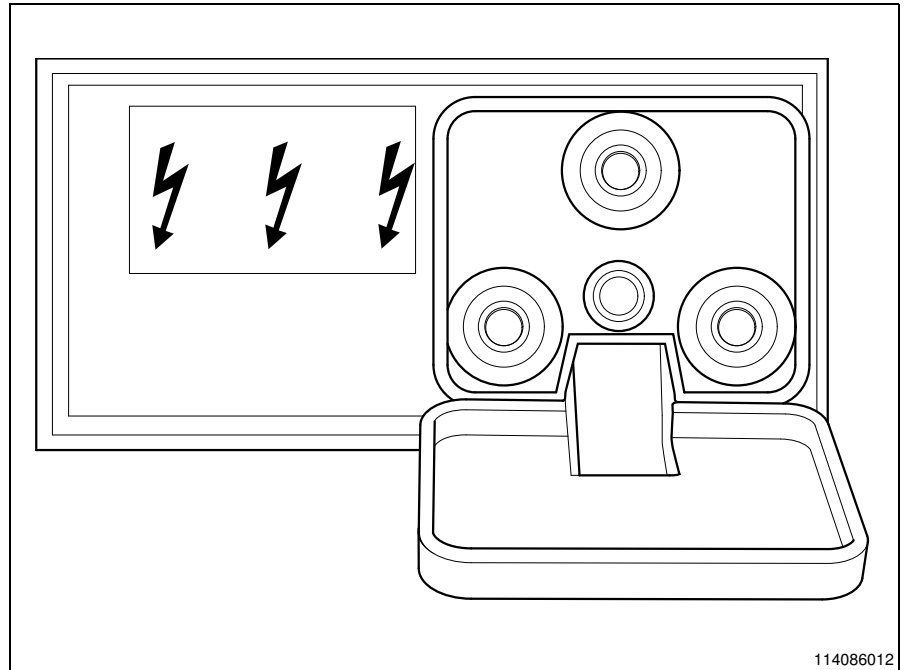

Fig. 28

#### Display explanation

<b>no indication</b>	$U < 10\% U_N$ , i.e. voltage-free
<b>half a lightning arrow</b>	$10\% \times U_N \leq U \leq 45\% \times U_N$ , i.e. voltage present
<b>complete lightning arrow</b>	Nominal voltage present

Table 2  $U_N$  = nominal voltage

**4.12 Short-circuit indicator (optional)**

The circuit-breaker panel can optionally be supplied with short-circuit indicators fitted. Two different types can be fitted.

**Short-circuit indicator fitted to the single-conductor cable (Fig. 29).**

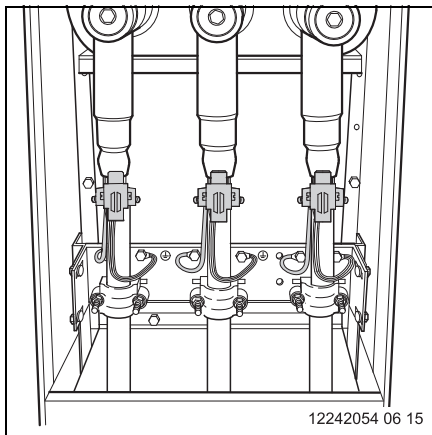

Fig. 29

These types can vary.

- Short-circuit indicator with rotor system. Here the rotating rotor must be manually reset after it has tripped.
- Short-circuit indicator with liquid. The red particles whirled up after tripping remain suspended for 4-8 hours; after this time the indicator is clear again (automatic reset).
- Short-circuit indicator with fluid (automatic reset) and micro-fleeting contact. The contact closes for the duration of the short-circuit and therefore makes possible remote signalling.

When installing the short-circuit indicators the earthing strand of the sealing end must be routed through the installation ring of the short-circuit indicator and connected to the earthing screw on the cable fixing iron. For the use of these short-circuit indication systems the front covers are provided with inspection windows (optional).

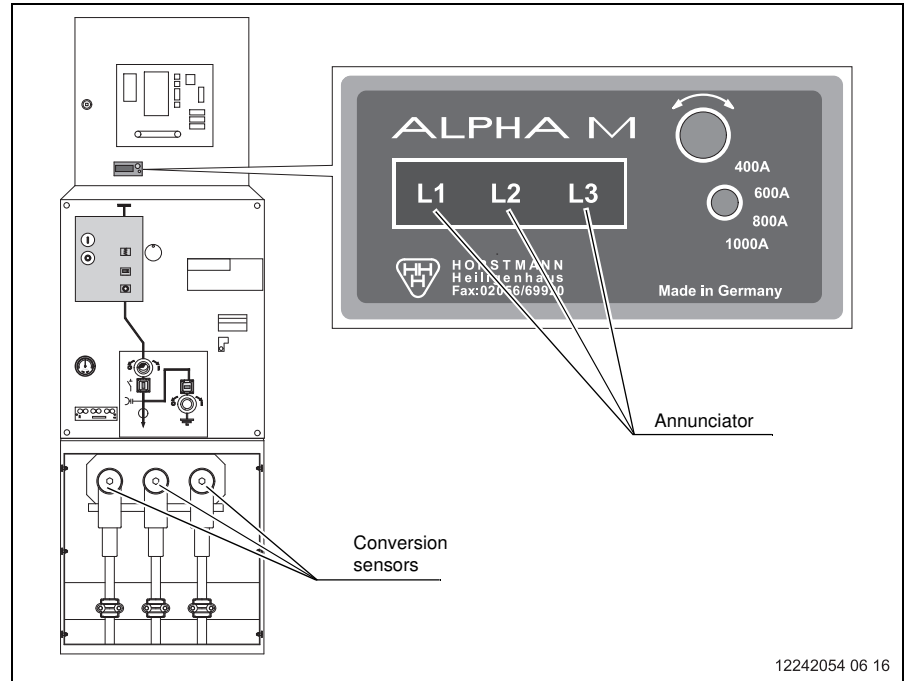

Fig. 30

**Short-circuit indicator for installation in front panel (Fig. 30).**

The indicator unit is integrated into a control panel plug-in housing acc. to DIN 43700 and is built into the circuit-breaker panels relay cabinet door. In the factory three conversion sensors are mounted to the bushing, electrically connected to the indicator unit and tested.

Four Horstmann short circuit indicators are used:

Short circuit indicator type	Reset	Short circuit current	Remote contact Standard wiper >100 ms Option: permanent contact
ALPHA M	- manual	400, 600, 800, 1000	Yes
ALPHA E	- manual - automatically after 2 or 4h	400, 600, 800, 1000	Yes
GAMMA 4.0	- manual - after mains return - automatically after 2 or 4h	400, 600, 800, 1000	Yes
ALPHA automatic (upon request)	- manual (per pushbutton) - Remote reset (by auxiliary voltage) - automatically after 3h	Current fluctuation of $\Delta I = 150 A$ for 20 ms	Yes

Table 3

## 5 Operation

### 5.1 Switching accessories

For operation of the circuit-breaker panel the following accessories are needed:

1. Switching lever for earthing switch (red shaft)  
(only in conjunction with 2-lever drive).
2. Switching lever for disconnecter (bare shaft)  
(optional for disconnecter and earthing switch (only in conjunction with 1-lever drive)).
3. Key for front cover fastener (controls the anti-reverse interlock).
4. Hand crank for circuit-breaker drive's spring accumulator

The switching levers used to switch the circuit-breaker panel are fitted with a non-positive lock, which prevents damage to the drive.

When trying to continue a switching operation in a switch position (ON/OFF) by application of force, the toggle of the switching lever will bend.

#### Attention!

Never leave the switching lever inserted in the actuating shaft, because operation of the other actuating shaft will damage the switching interlock of the panel.

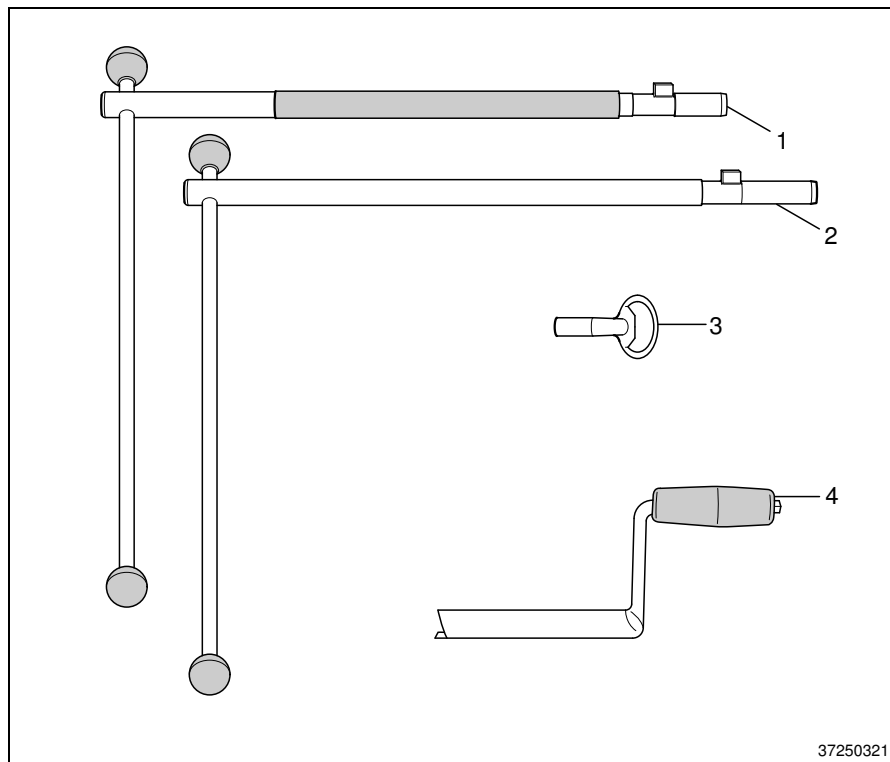

Fig. 31

## 5.2 Padlocking facility

The circuit-breaker panel is fitted with padlocking facilities as standard (Fig. 32). The padlocking facility is opened by pressing the thumb against the locking resistance of the locking cover in clockwise direction. The padlocking facility stops in end position by means of an integrated stop, so that also the adjacent padlocking facility can be opened.

To ensure that switching actions are always fully carried out, gates are fitted to the switch actuators. These ensure that the switching lever can only be removed in the relevant end limit position.

**Note!**

In the description of the switching operations in chapters 5.3 and 5.4 the padlocking facilities are not shown, for the purpose of a clearer representation of switch position indicators and actuating shafts.

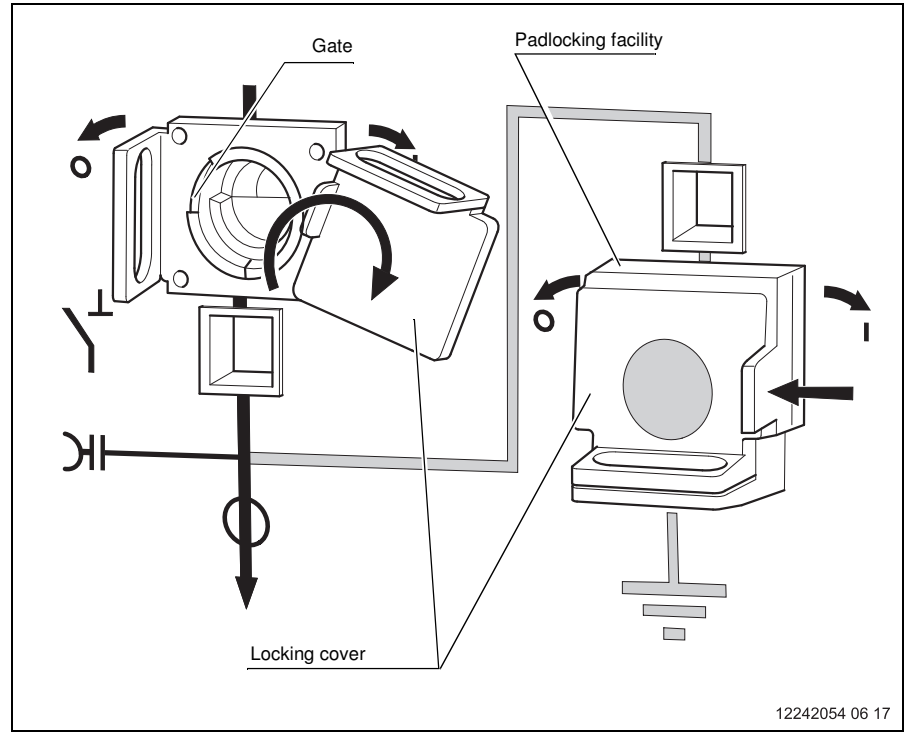

Fig. 32

### 5.3 Delivery state of the circuit-breaker panel

When delivered, the circuit-breaker panel is in the following state:



Figure 33

Fastener closed (anti-reverse interlock optional).

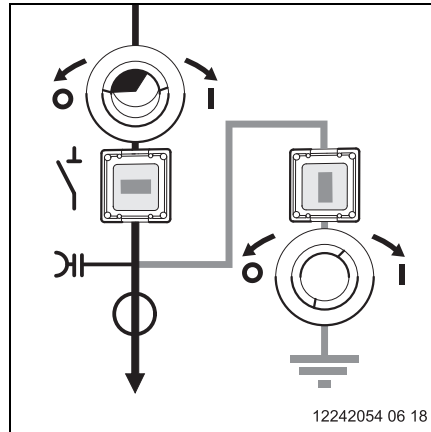

Figure 34

Disconnector switched OFF and locked by the switching interlock. Earthing switch activated.

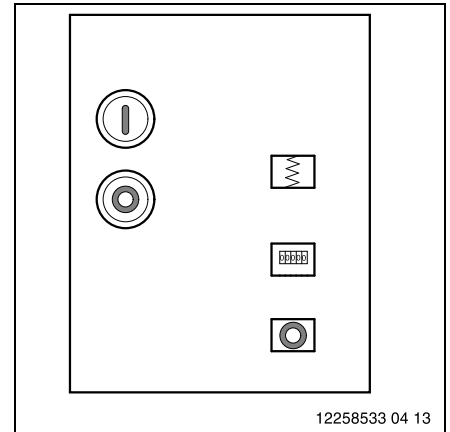

Figure 35

Circuit-breaker switched OFF, spring accumulator relaxed.

In the switch state described, the front cover is removable, because the pin of the front cover interlock (see Fig. 37 and Chapter 4.9, Panel Interlocks) has been pulled out of the front cover.

#### Remove the front cover.

- Open the fastener. Turn the fastener anti-clockwise to the end stop, using the fastener key.
- Raise the front cover up to the stop (Fig. 36/1).
- Pull the front cover off to the front (Fig. 36/2).

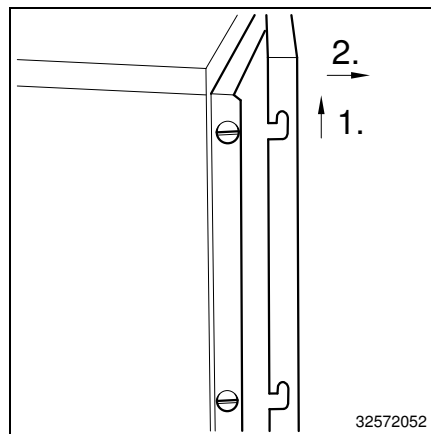

Fig. 36 Front cover

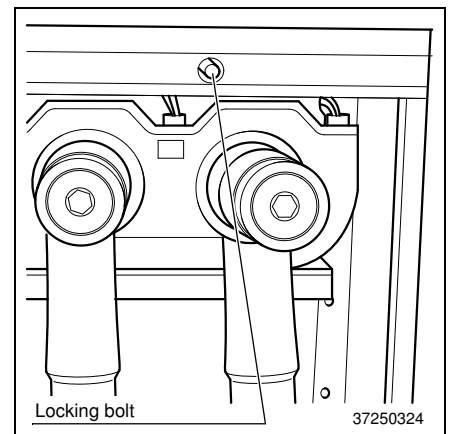



Fig. 37 Front cover interlock

## 5.4 Switching the circuit-breaker panel

### 5.4.1 Inspection activities and safety instructions

 Before switching the circuit-breaker panel, check the gas pressure gauge. In case of a red indication the circuit-breaker panel must not be switched! In such a case inform the customer service.

 During each switching process (connection to or disconnection from the mains) the function of the capacitive voltage detecting system must be checked, if a de-energised state is detected (see Chapter 6.5). Always check all phases L1, L2, L3!

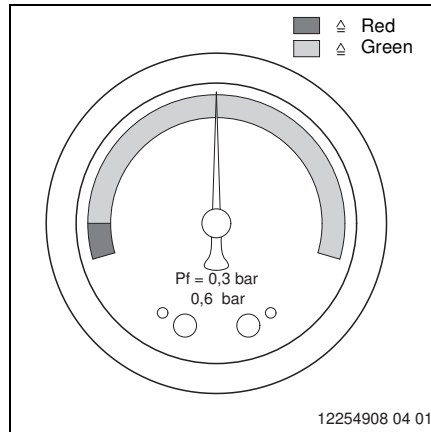

Fig. 38

Gas overpressure correct - system may be operated.

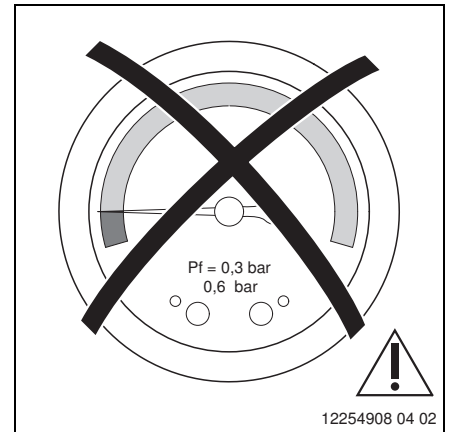



Fig. 39

 Gas overpressure **not** correct – switchgear must **not** be operated.

Before switching the circuit-breaker switch the fastener must be closed with the fastener key (Figure 40).

**Note!**

The disconnecter and earthing switch are mechanically locked with each other. If the earthing switch is switched ON the plug-in opening on the switching shaft of the corresponding disconnecter switch is closed by a locking plate.

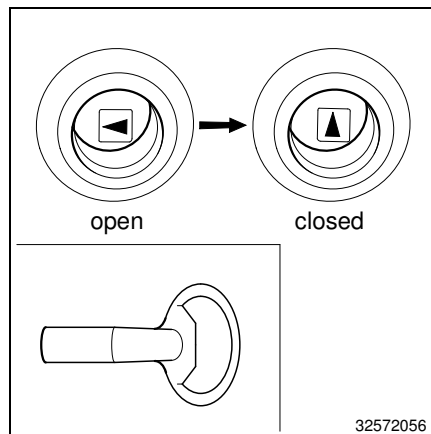

Figure 40

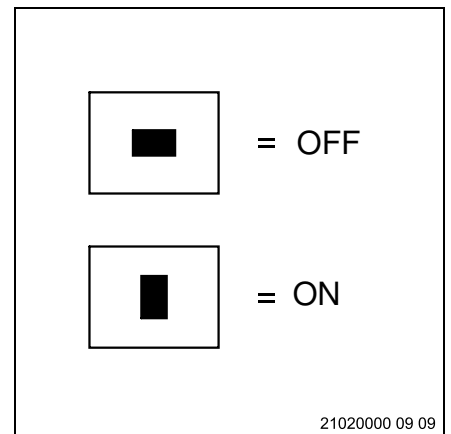

Figure 41

The switching state of the disconnecter and earthing switch can be read off the switch position indicators in the circuit-breaker panels mimic diagram (Figure 41).

#### 5.4.2 Tensioning the spring accumulator

Insert the hand crank into the tensioning coupling. Tension the spring accumulator by turning the crank to the right (approx.4.5 turns).

Once the maximum accumulator energy has been reached, the drive ratchet switches to idle. The spring accumulator indicator jumps to 'TENSIONED' (Fig. 42).

The spring accumulator is automatically pre-tensioned by the motor when the supply voltage is present.

On the failure of the supply voltage, the spring accumulator can be tensioned manually using the crank. The hand crank coupling is designed such that if the motor power supply becomes available again, the tensioning crank is de-coupled.

The energy from the tensioned closing spring allows the the circuit-breaker to be switched ON whilst simultaneously tensioning the opening spring. Re-tensioning the closing spring immediately after switching the circuit-breaker ON makes it possible to switch a brief interruption OFF-ON-OFF.

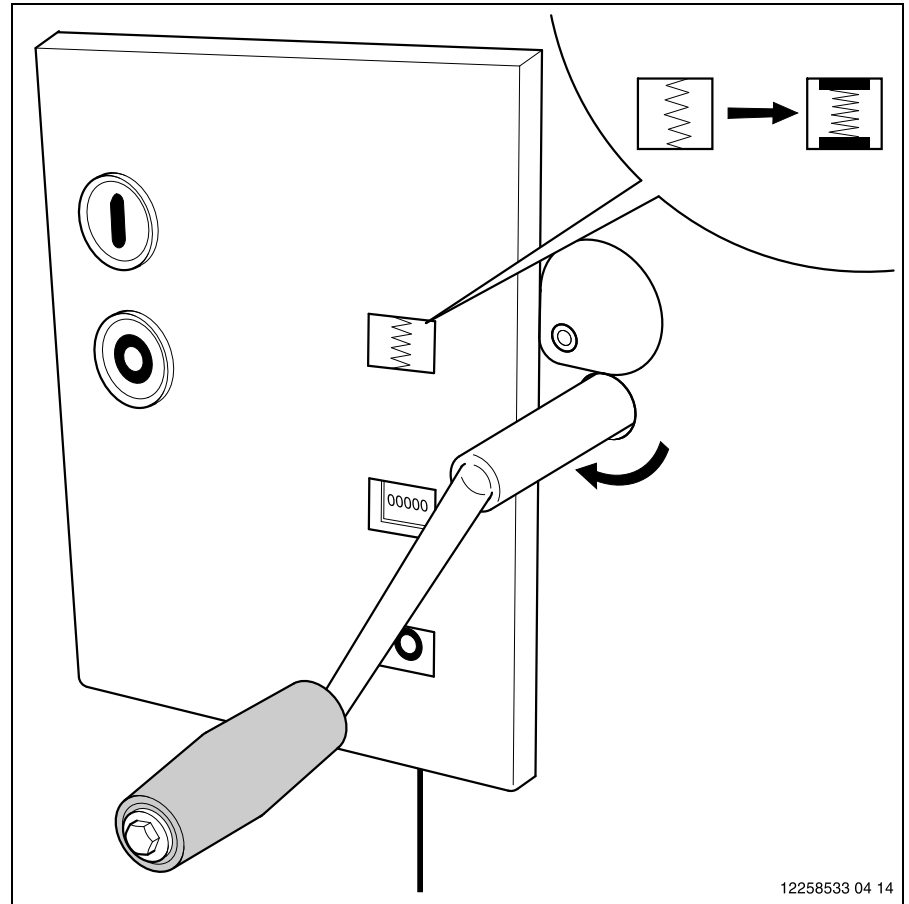

Fig. 42

### 5.4.3 Switching the circuit-breaker panel ON

To **switch the circuit-breaker panel ON**, proceed as follows:

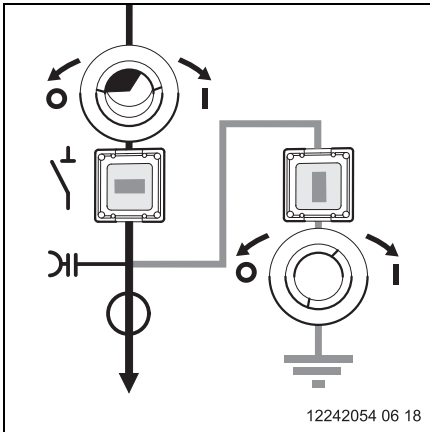

Fig. 43

**1** Switch position with deactivated disconnecter and activated earthing switch (Fig. 43),

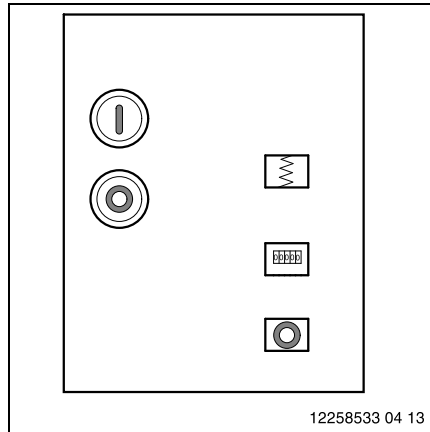

Fig. 44

circuit-breaker switched OFF and relaxed spring accumulator (Fig. 44).

**⚠** Check that the switch panel is electrically isolated means of the capacitive voltage detection system (see Chapter 6.5).

**2** Tension the spring accumulator, until the spring accumulator indicator jumps to TERNSIONED (see Chapter 5.4.2).

**Note!**  
If a motor drive is fitted and the supply voltage is available, the spring accumulator is automatically pre-tensioned.

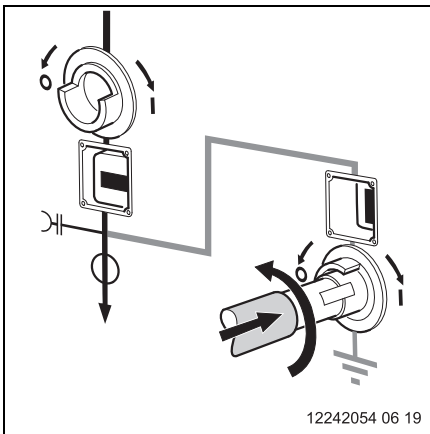

Fig. 45

**3** Switch off the earthing switch. Hold the switching lever (red shaft) depressed to the end stop against spring pressure and turn it anti-clockwise (Fig. 45).

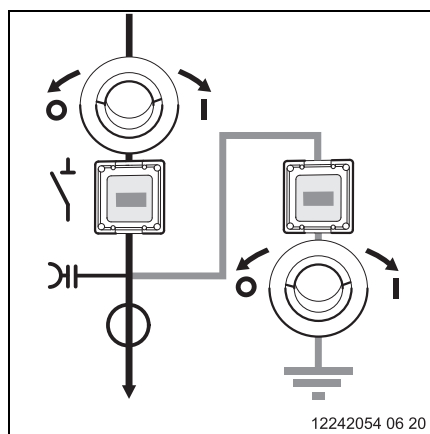

Fig. 46

**4** Switch position with deactivated disconnecter and deactivated earthing switch (Fig. 46),

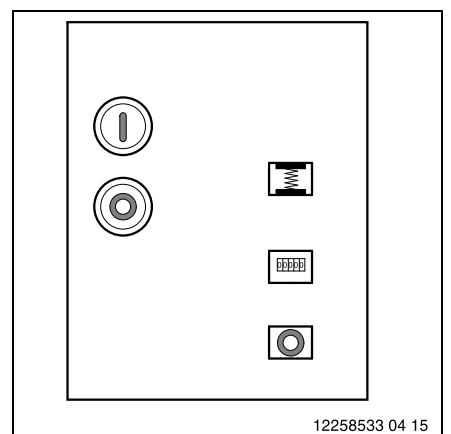

Fig. 47

circuit-breaker switched OFF and tensioned spring accumulator (Fig 47).

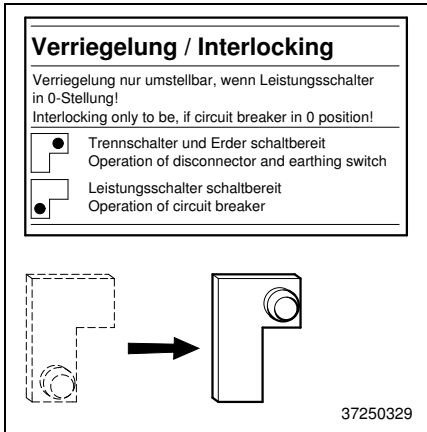

Fig. 48

**5** Deactivate the interlock between the circuit-breaker and the disconnector or earthing switch respectively. Do this by moving the operating lever from the bottom left to the top right position (Fig. 48) (see also Chapter 4.9, "Panel Interlocks").

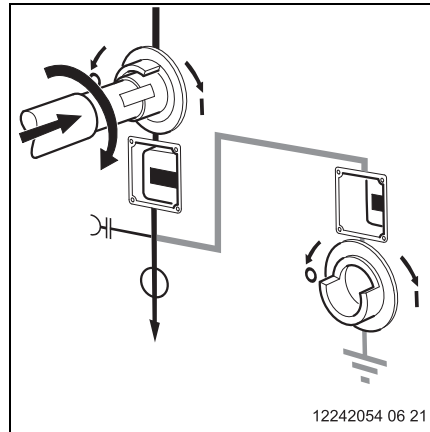

Fig. 49

**6** Switch the disconnector ON. Hold the switching lever (bare shaft) depressed to the end stop against spring pressure and turn it clockwise (Fig. 49).

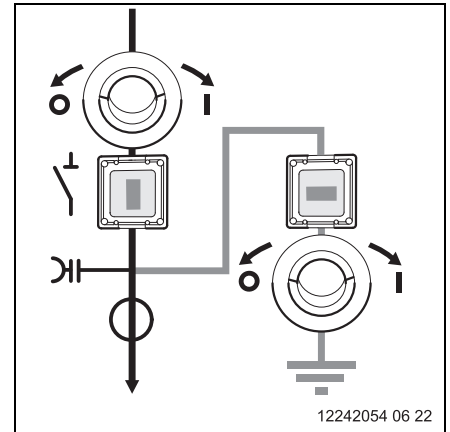

Fig. 50

**7** Switch position with activated disconnector and deactivated earthing switch (Fig. 50).

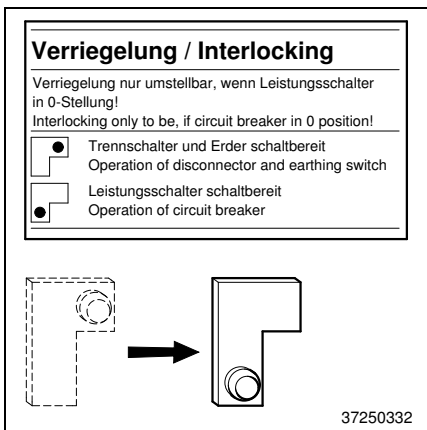

Fig. 51

**8** Activate the interlock between the circuit-breaker and the disconnector or earthing switch respectively. Do this by moving the operating lever from the top right to the bottom left position (Fig. 51) (see also Chapter 4.9, "Panel Interlocks").

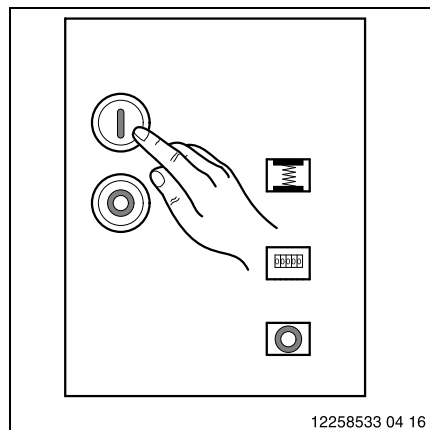

Fig. 52

**9** Switch the circuit-breaker ON. To do this, press the pushbutton ON (I) on the circuit-breaker control panel (Fig. 52). The spring accumulator indicator jumps to RELAXED.



Use the capacitive voltage detection system to check whether voltage is indicated for phases L1, L2 and L3 (see Chapter 6.5).

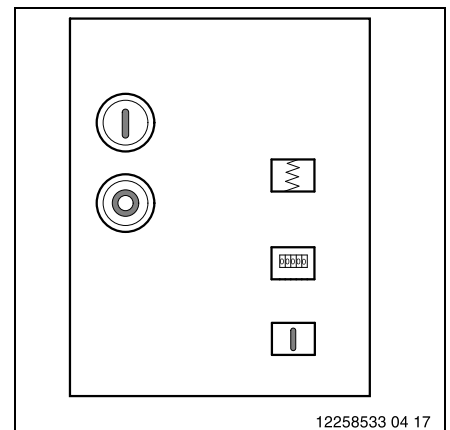

Fig. 53

**10** Switch position with circuit-breaker switched ON and relaxed spring accumulator (Fig. 53).

### 5.4.4 Switching the circuit-breaker panel OFF

To **switch the circuit-breaker panel OFF**, proceed as follows:



Use the capacitive voltage detection system to check whether voltage is indicated for phases L1, L2 and L3 (see Chapter 6.5).

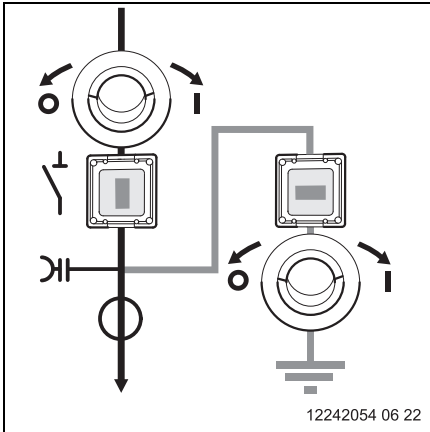

Fig. 54

**1** Switch position with activated disconnecter and deactivated earthing switch (Fig. 54),

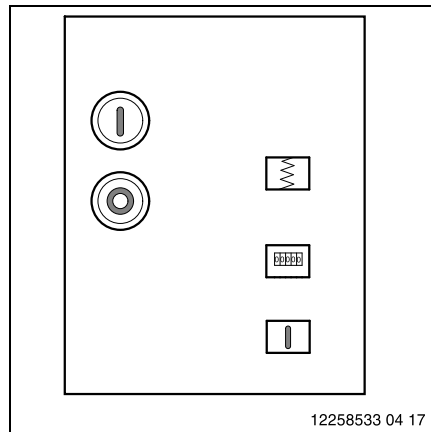

Fig. 55

circuit-breaker switched ON and relaxed spring accumulator (Fig. 55).

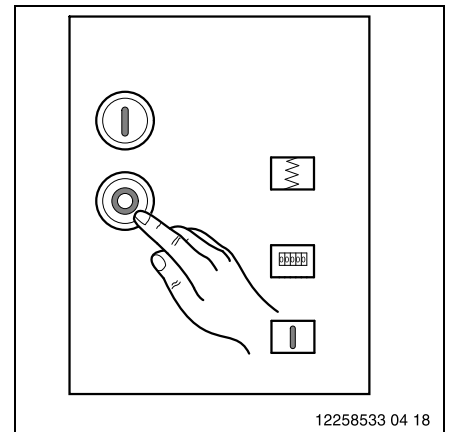

Fig. 56

**2** Switch the circuit-breaker OFF. To do this, press the pushbutton OFF (0) on the circuit-breaker control panel (Fig. 56).



Check that the switch panel is electrically isolated using capacitive voltage detecting system (see Chapter 6.5).

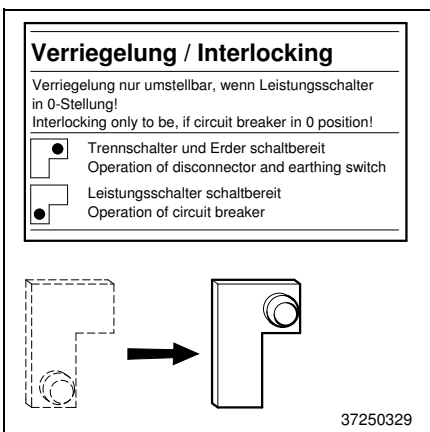

Fig. 57

**3** Deactivate the interlock between the circuit-breaker and the disconnecter or earthing switch respectively. Do this by moving the operating lever from the bottom left to the top right position (Fig. 57) (see also Chapter 4.9, "Panel Interlocks").

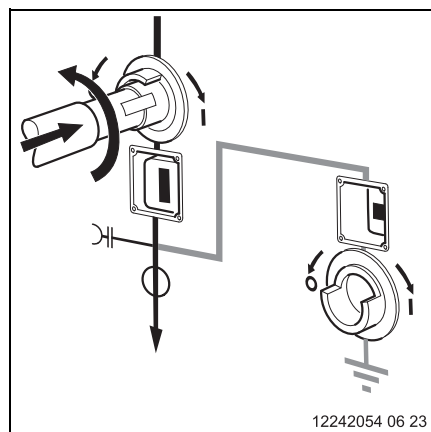

Fig. 58

**4** Switch the disconnecter OFF. Hold the switching lever (bare shaft) depressed to the end stop against spring pressure and turn it anti-clockwise (Fig. 58).

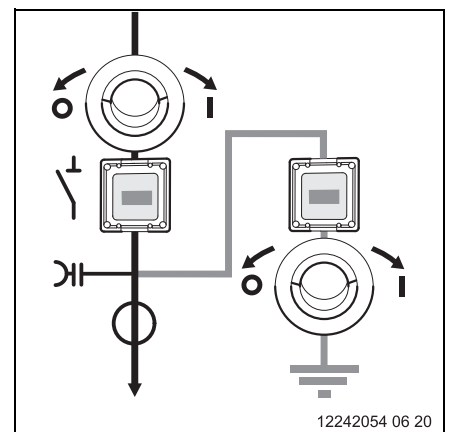

Fig. 59

**5** Switch position with deactivated disconnecter and deactivated earthing switch (Fig. 59).

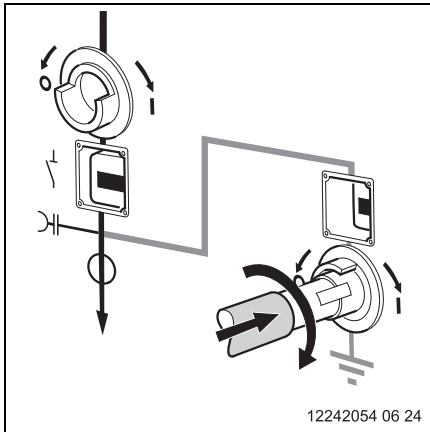

Fig. 60

**6** Switch on earthing switch. Hold the switching lever (red shaft) depressed to the end stop against spring pressure and turn it clockwise (Fig. 60).

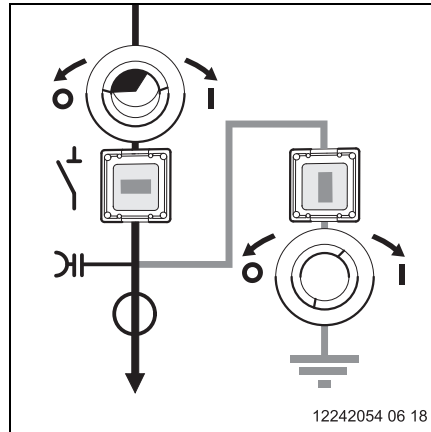

Fig. 61

**7** Switch position with deactivated disconnecter and activated earthing switch (Fig. 61),

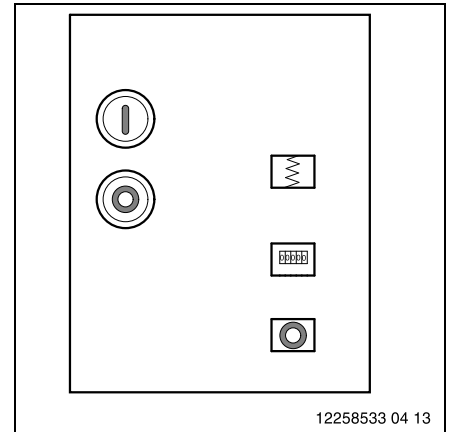

Fig. 62

circuit-breaker switched OFF and relaxed spring accumulator (Fig. 62).

## 6 Commissioning

### 6.1 Inspection activities and safety instructions

To commission the circuit-breaker panel, its correct function is to be ensured by inspecting the following points:

- Please compare the data on the rating plate and the data on the delivery paperwork with the order documentation.
- Check the secondary equipment in accordance with the information in the circuit documentation for the related switchgear configuration.
- Check all screwed connections (cable connections, operational earthing, panel screw connections) for correct seating (torque) and proper fastening.
- Check the operating pressure available on the gas pressure gauge (the pointer must be in the green sector).



When installing a circuit-breaker panel as an end panel, make sure that the sealing ends are correctly fitted to the lateral bushings and that the bottom screw connection point is closed off with the screw plug. When doing so, observe the assembly instructions "Panel screw connection for extensible GAE630 panels", article no. 12244002.

**Note!**

We recommend during commissioning on site, after completion of the assembly, to perform a power frequency voltage withstand test as per VDE 0671 part 200 / DIN EN 62271-200 section 7.105.

### 6.2 Switching the circuit-breaker panel (manually)

The following operating sequences are to be followed.

**Note!**

The switch panel is delivered with the front panels earthed (see Chapter 5.3).

**SWITCHING ON**

- Switch the earthing switch OFF
- Switch the disconnecter ON
- Throw the locking lever
- Tension the circuit-breaker's drive using the hand crank.
- Switch the circuit-breaker ON.

**SWITCHING OFF**

**Attention!**

Check that the switch panel is electrically isolated using capacitive voltage detecting system (see Chapter 6.5)

- Switching the circuit-breaker OFF
- Throw the locking lever
- Switch the disconnecter OFF
- Switch on earthing switch

### 6.3 Undervoltage release (optional)

If the circuit-breaker panel is equipped with an undervoltage release, this is mechanically inhibited by the manufacturer. The undervoltage release's mechanical inhibitor must be removed before the circuit-breaker panel is commissioned.

Do this by applying an auxiliary voltage to the undervoltage release and pulling out the clamp, which is attached to a cord.

**Attention!**

When the supply voltage is applied, the motor drive runs up immediately and tensions the circuit-breaker's spring accumulator!

When the auxiliary voltage is applied, the trip's solenoid energises. The circuit-breaker can be switched ON. If the auxiliary voltage fall below a specified value, the solenoid is de-energised and the circuit-breaker switches OFF.

The undervoltage release is set up in the factory and sealed on the installation board.

#### 6.4 Switching using motor drive (option)

To test switching using the motor drive, switch on the supply voltage. The motor drive starts immediately and tensions the spring accumulator.

The indication states of the spring accumulator are to be checked mechanically and with the supply voltage. To do this, switch the drive, as described in Chapter 6.2 and check the mechanical and electrical switch position indication.

#### SWITCHING ON

Prerequisite for switching the circuit-breaker ON is that the mechanical interlocks and the solenoid-operated locks are not activated.

Press the "ON" pushbutton or activate the remote release's control device (switch ON via the making trip) until such time as the circuit-breaker is switched ON and the switch position indicator indicates and reports "ON".

#### Note!

During the switching process, the "spring accumulator tensioned" indication is no longer visible. After switching on, the spring accumulator is immediately automatically tensioned by the motor drive for an automatic reclosure. The "spring accumulator tensioned" indication becomes visible again.

#### SWITCHING OFF



Check that the switch panel is electrically isolated using capacitive voltage detecting system (see Chapter 6.5).

To switch the circuit-breaker OFF, press the "OFF" pushbutton or activate the corresponding remote release's control device (switch OFF via the breaking trip) until the circuit-breaker is switched OFF and the switch position indicator indicates and reports "OFF".

#### 6.5 Checking for electrical isolation

Before disconnecting a circuit-breaker panel in operation from the mains and prior to connecting a circuit-breaker panel to the mains, the panel must be checked for electrical isolation.



Checks are always to be made on all three poles!

The test is performed using the following procedure:

- With the circuit-breaker panel switched ON, open the shrouds on the capacitive measuring points.
- Insert a voltage tester (see Table 1, Chapter 4.11) in each of the three measuring sockets.

The voltage testers **must** flash.

- Switch the circuit-breaker to OFF.
- Switch the disconnecter to OFF.
- Isolate also the second cable end.
- Switch the earthing switch to "ON".

The outgoing cable is now electrically isolated. The voltage testers **must no longer** flash!

- Upon completion of the test remove the voltage testers and turn back the shrouds to close the capacitive measuring points.

### 6.6 Phase comparison



A phase comparison between two outgoing lines can be performed at the insulated test sockets (Fig. 63).

Phase comparator e. g. Messrs. Horstmann: type ORION, manuf. Pfisterer: type EPV, manuf. ELSIC: type HO-PV).

The correct function of the phase comparison device must be checked in compliance with the instructions of the manufacturer.

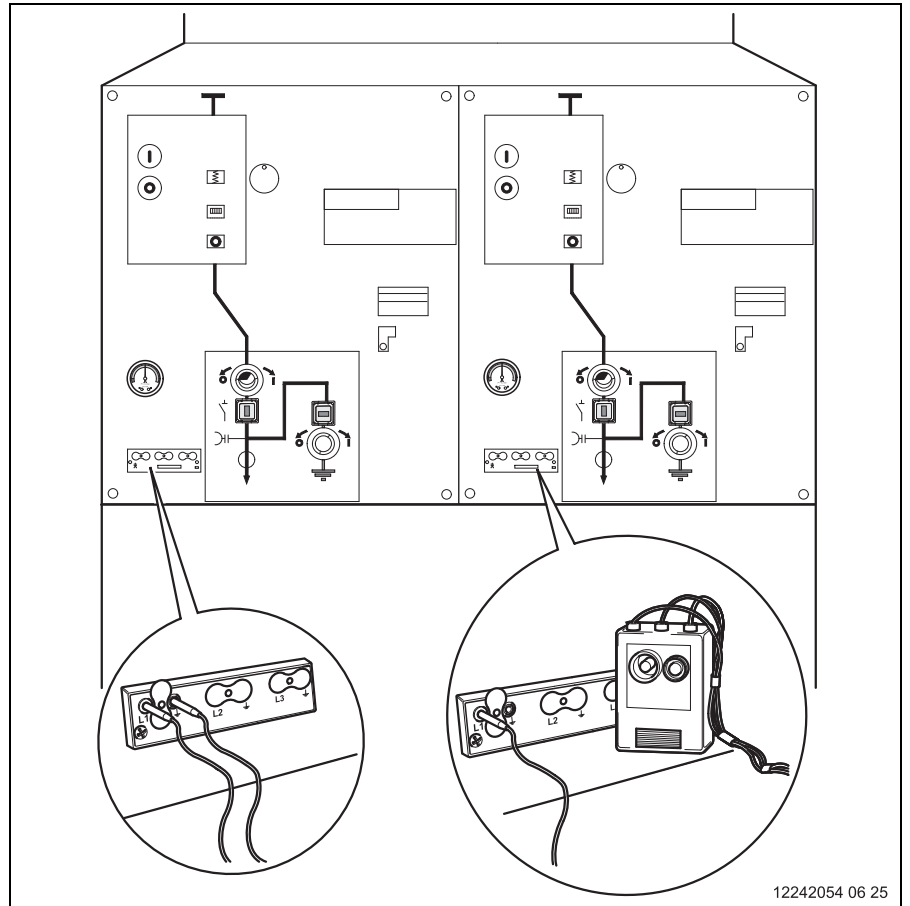

Fig. 63



## 6.7 Cable test

The power cable test is performed on the appropriately equipped cable set.

Fig. 64 shows a plug-in cable adapter of the AWK 10 type with assembled testing adapter of the PAM 400 type.

Fig. 65 shows a male cable connector of type AWKS with assembled testing adapter of type PAK 630.

To carry out a cable test the following steps must be performed:

- Open the plugs for the capacitive measuring points.
- Insert 3 voltage testers into the measuring sockets.

The voltage testers **must** flash.

- Switch the circuit-breaker to "OFF".
- Move the interlock operating lever from the bottom left-hand to the top right-hand position
- Switch the disconnector to "OFF".
- Isolate also the second cable end.

The voltage testers **must no longer** flash!

- Switch the earthing switch to "ON".
  - Remove the front cover.
  - Unscrew the threaded insert from the male cable adapter.
  - Screw the test adapter onto the threaded pin inside the male cable adapter (observe the tightening torque).
  - Switch the earthing switch to "OFF".
  - Perform measurement/test.
- The panel can be tested with a maximum direct voltage of  $8 \times U_0 = 96 \text{ kV}$ , whereby the busbars may be applied to a maximum rated voltage of 24 kV!

After completion of the cable test:

- Switch the earthing switch to "ON".
- Unscrew the testing adapter.
- Screw in the threaded insert from the male cable adapter (observe tightening torque).
- Insert the front cover.

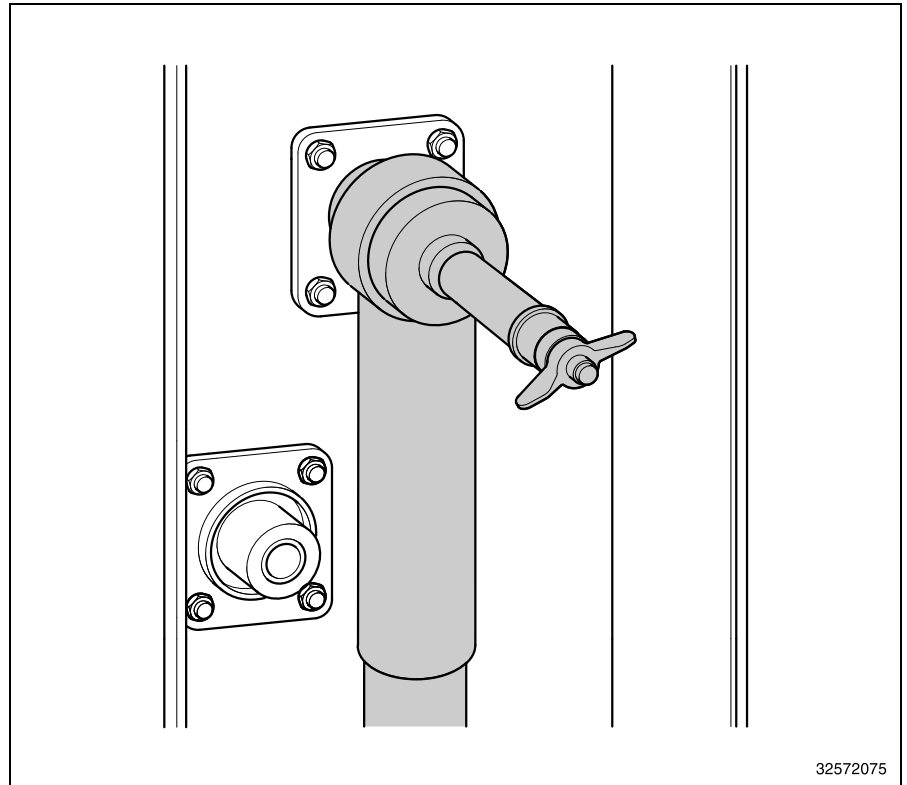

Fig. 64

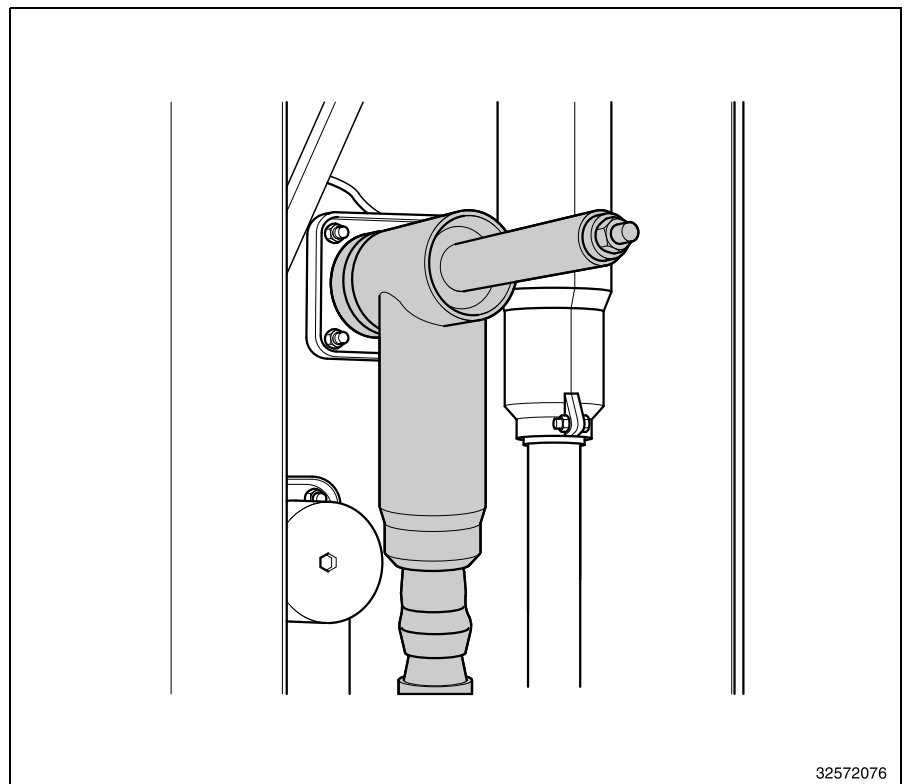

Fig. 65

## 7 Maintenance

### 7.1 General



Maintenance, repair work and subsequent modifications must only be performed by skilled personnel and in compliance with the operating instructions, the accident prevention instructions and the regulations of the liability associations.

Maintenance is used to ensure continuing trouble-free operation and the longest possible service lifetime of the switching device and the equipment integrated. It covers the following, closely related areas in accordance with DIN 31051 or IEC 1208 respectively:

- **Inspection:**  
Determination of the actual state
- **Maintenance:**  
Measures to preserve the nominal state (ensuring trouble-free function)
- **Repair:**  
Measures to restore the nominal state.

The circuit-breaker panel is low-maintenance.

The gas tank is welded gas-tight and all components inside are maintenance-free.

The SF<sub>6</sub> gas is resistant to ageing and is not consumed during the switching operations.

Under normal conditions, the gas charge does not need to be replaced during the operational life of the circuit-breaker panel.

The vacuum circuit-breakers feature a simple and robust design. They have a long life expectancy. Their drives are low maintenance and the vacuum contact chambers are maintenance-free for their entire service lifetime.

Even frequent switching of operating and short-circuit currents will not degrade the vacuum.

The maintenance intervals for the mechanical assembly on the vacuum circuit-breaker are defined by the ambient conditions, operating frequency and number of short circuit breaks.

### 7.2 Inspection and maintenance

#### 7.2.1 Inspection



Prior to inspection, electrically isolate and secure the operating range in accordance with the "safety rules" specified by DIN VDE/IEC.

An inspection, in accordance with BGV A3 should be carried out approximately every 4 years, depending upon the operating conditions and local circumstances.

In exceptional operating conditions (these also include harsh climatic conditions) and/or heavy pollution (including heavy soiling and aggressive air), inspection may be required at significantly shorter intervals.

Inspection includes:

- Check the SF<sub>6</sub> gas tank for loss of pressure. As long as the pointer in the gas leakage indicator is in the green sector the pressure is sufficient.

- Check switchgear and switching devices for anything unusual, soiling and the result of environmental effects.
- Perform several no-load switching operations, this instruction applies particularly to circuit-breakers that are switched infrequently in operation.
- Check function of the switching device, e. g. its actuating device, interlocking devices, trigger devices and signalling devices and any other devices.
- Shut down motor winding (if fitted). On the circuit-breaker, actuate the ON and OFF pushbuttons as follows: OFF-ON-OFF.
- Inspect the condition of the lubrication at the bearing points, sliding surfaces, etc. (see \* in Fig. 66).
- Determine the subsequent measures (maintenance, service) taking into account the number of operating cycles (see Fig. 67).

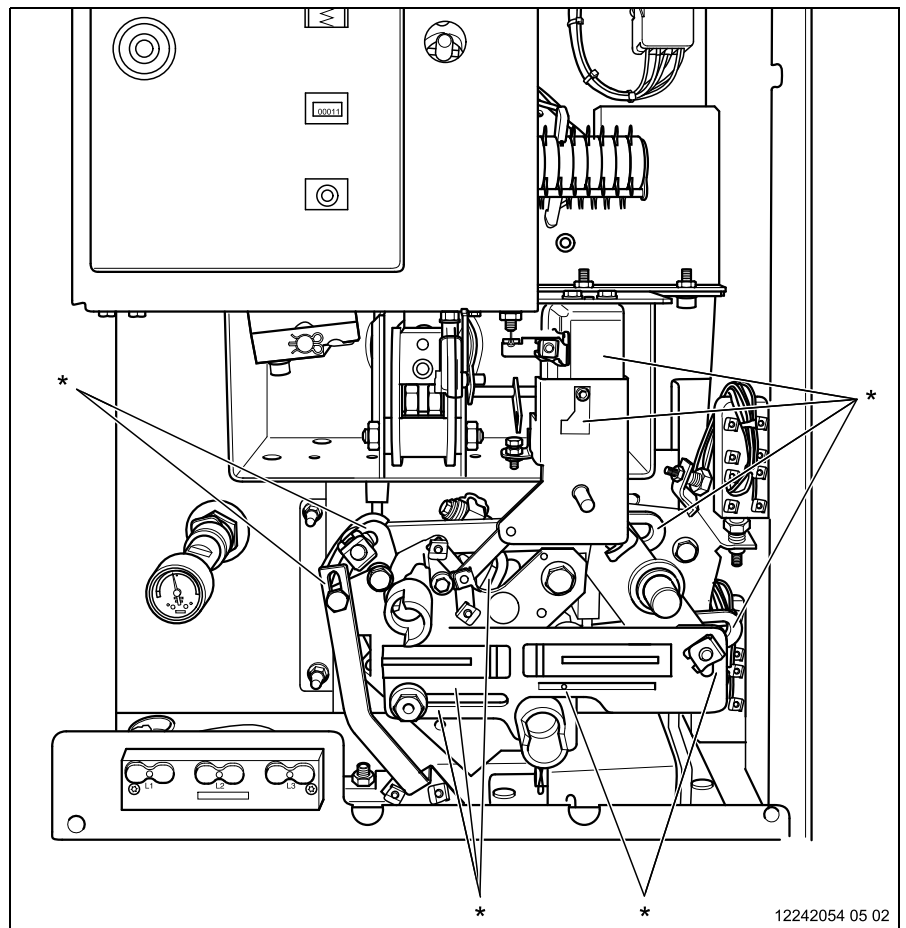

Fig. 66

12242054 05 02

## 7.2.2 Maintenance



Prior to maintenance, electrically isolate and secure the operating range in accordance with the "safety rules" specified by DIN VDE/IEC.

Maintenance is to be performed:

- at an interval of 10 years after commissioning,
- If found necessary during the inspection.

## 7.2.3 Cleaning the circuit-breaker panel

If the circuit-breaker panel is operated under dirty conditions or in aggressive air, the surfaces must be cleaned during maintenance.

### Attention!

Before starting cleaning work the circuit-breaker panel must be isolated.



To avoid unintended operation, the supply voltage is to be shut down.

Cleaning is performed using the following procedure:

- Manually switch on and off circuit-breaker (spring accumulator tension is released, switch position indicator is in the "OFF" position).
- Switch on earthing switch
- Open the fasteners and remove the front covers (if required).

Carefully clean off all dirt, especially from the surfaces of insulating materials. Clean off strongly adhesive, e. g. greasy, dirt with a lint-free cloth soaked in a commercial detergent, then wipe off with clear water and dry.

### Attention!

Do not use any aggressive solvents!

## 7.2.4 Scope of maintenance on the vacuum circuit-breaker's mechanical drive groups

- Shut down motor winding (if fitted).
- On the circuit-breaker, actuate the ON and OFF pushbuttons as follows: OFF-ON-OFF.
- Remove the control panel cover as described in Chapter 3.9.
- Assess the overall condition of the operating mechanism.
- Clean the surfaces with a soft, dry, lint-free cloth
- To re-lubricate friction surfaces and bearings with resin- and acid-free lubricants (see Chapter 8.10) please contact our customer service department. Re-lubrication serves to refresh the lubricant.
- Re-fit the control panel cover.

### Note!

In case of problems during the maintenance work and in case of malfunctions, please contact the plant where the unit was manufactured.

### The following information is required on contacting the manufacturer:

- Type
- Serial number
- Year of manufacture

### 7.3 Fault clearance on the vacuum circuit-breaker

Fault	Possible cause(s)	Remedial action
1. Shunt release does not trip	<ul style="list-style-type: none"> <li>– no voltage</li> <li>– voltage level too low</li> <li>– with DC releases, polarity reversed</li> <li>– release defective</li> <li>– impulse duration too short</li> </ul>	<ul style="list-style-type: none"> <li>– Check supply lines and plug-in connections (refer to circuit diagram)</li> <li>– Check the voltage source</li> <li>– Contact the manufacturer</li> <li>– Observe the impulse duration</li> </ul>
2. Undervoltage release does not trip	<ul style="list-style-type: none"> <li>– Inhibitor still in place</li> <li>– further, see item 1</li> </ul>	<ul style="list-style-type: none"> <li>– Remove the inhibitor</li> <li>– see item 1</li> </ul>
3. Motor winder does not tension	<ul style="list-style-type: none"> <li>– no voltage</li> <li>– voltage level too low</li> <li>– motor defective</li> </ul>	<ul style="list-style-type: none"> <li>– see item 1</li> </ul>
4. Switch position indicator ON/OFF in intermediate position	<ul style="list-style-type: none"> <li>– Cover box not fitted correctly</li> </ul>	<ul style="list-style-type: none"> <li>– Relax the closing spring with switch sequence OFF-ON-OFF, remove the cover box and when re-fitting it, make certain that the indicator linkage locates correctly.</li> </ul>
5. Switch switches OFF immediately after being switched ON	<ul style="list-style-type: none"> <li>– permanent "OFF" signal present</li> <li>– undervoltage release not activated, if fitted</li> </ul>	<ul style="list-style-type: none"> <li>– see item 1</li> </ul>
6. Switch can not be switched ON mechanically	<ul style="list-style-type: none"> <li>– if key lock is fitted</li> </ul>	<ul style="list-style-type: none"> <li>– Unlock</li> </ul>
7. Switch can neither be switched ON mechanically nor electrically	<ul style="list-style-type: none"> <li>– electrical closing lock-out not activated</li> </ul>	<ul style="list-style-type: none"> <li>– Apply a supply voltage</li> <li>– see item 1</li> </ul>
8. Switch can not be switched ON electrically	<ul style="list-style-type: none"> <li>– see item 1</li> </ul>	<ul style="list-style-type: none"> <li>– see item 1</li> </ul>

Table 4

### 7.4 Return of switchgear

For Ormazabal circuit-breaker panels a 30-year operating life is assumed. The "hermetically sealed pressure system" acc. to IEC does not require re-filling of the SF<sub>6</sub> gas over the entire operating life. Due to the high reliability of the circuit-breaker panels, arc-faults are almost completely excluded.

The handling of switchgear that has failed or has been taken out of operation because of such incidents and the implementation of safety measures is described in the leaflet "SF<sub>6</sub> systems", issued by the German official labour association for precision engineering and electrical engineering.

The Krefeld location has been certified in accordance with DIN EN ISO 9001 since 1993 and fulfils the requirements of DIN EN ISO 14001 and consistently implements operational environmental protection with the environmental management system.

As a competent partner Ormazabal offers you the option of returning your circuit-breaker panel after the expiration of the above mentioned operating time. The costs involved depend on the legal requirements applicable at the time of return.

This switchgear contains the fluorinated greenhouse gas SF<sub>6</sub> covered by the Kyoto Protocol and with a global warming potential (GWP) 22200. SF<sub>6</sub> must be recovered and not released into the atmosphere.

For further information on use and handling of SF<sub>6</sub> please refer to IEC 62271-303: High-voltage switchgear and controlgear – Part 303 Use and handling of sulphur hexafluoride (SF<sub>6</sub>).

All other materials of this switchgear should also be recycled.

## 8 Technical data

### 8.1 General data

Insulating gas		SF <sub>6</sub>
Rated density of insulating gas		7.9 kg/m <sup>3</sup>
Rated filling pressure of insulating gas at 20 °C and 101.3 kPa		130 kPa (30 kPa overpressure)
SF <sub>6</sub> -filling capacity at 20 °C and 101.3 kPa		1.20 kg
Ambient temperature T	with secondary equipment	-5 to +40 °C <sup>1)</sup>
	average maximum value over 24 h	+35 °C
	with reduced rated currents	above +40 °C
Relative humidity	measured over 24 h	maximum 95 %
	measured over 1 month	maximum 90 %
Enclosure of HV compartment		sealed pressure system acc. to IEC, IP 65/IP3XD
Internal arc classification according to VDE 0671 part 200 or IEC 62271-200 respectively		IAC AFL 20 kA 1 s for HV compartment and connection compartment
Coloration of equipment		RAL 7035 (light grey)
Loss of service continuity category		LSC 2A
Partition class		PM
Weight		approx. 330 kg (approx. 420 kg with pressure absorber channel)

Table 5

1) Usage at lower temperatures on request

### 8.2 Circuit-breaker panel GAE630 -1LSV(G)630 ratings

		12 kV	24 kV <sup>1)</sup>
Rated frequency	f <sub>r</sub>	50 (60) Hz	50 (60) Hz
Rated voltage	U <sub>r</sub>	12 kV	24 kV
Rated short-duration power-frequency withstand voltage 1 min.	U <sub>d</sub>	28 kV	50 kV
Transient voltage rate of rise		0.34 kV/μs	0.47 kV/μs
Rated insulation level	U <sub>p</sub>	75 kV	125 kV
Rated peak withstand current	I <sub>p</sub>	50 kA	40 kA
Rated short-time withstand current 1 s, and 3 s	I <sub>k</sub>	20 kA	16 kA
Rated busbar current	I <sub>r</sub>	630 A	630 A
Rated outgoing current	I <sub>r</sub>	630 A	630 A
Rated operating sequence		O - 0.3s - CO - 15 s - CO	O - 0.3s - CO - 15 s - CO
Direct current component		33 %	33 %
Rated cable-charging breaking current	I <sub>c</sub>	50 A	50 A
Rated line-charging breaking current	I <sub>i</sub>	10 A	10 A
Mechanical operating cycles (ON/OFF) Earthing switch	n	>1000	>1000
Mechanical operating cycles (ON/OFF) Circuit-breaker, disconnecter	n	10000	10000
Class		E1 / M2 / C2	E1 / M2 / C2

Table 6

1) increased rated voltage (25 kV) optional

### 8.3 Switchgear ratings

Circuit-breaker panel		10/12 kV			20/24 kV		
		Disconnecter	Earthing switch	Circuit-breaker	Disconnecter	Earthing switch	Circuit-breaker
Rated lightning impulse withstand voltage of the isolating distance	$U_p$	85 kV	-	-	145 kV	-	-
Rated current	$I_r$	630 A	-	630 A	630 A	-	630 A
Rated short circuit load breaking current	$I_{sc}$	-	-	20 kA	-	-	16 kA
Rated peak withstand current	$I_p$	50 kA	50 kA	50 kA	40 kA	40 kA	40 kA
Rated short-time withstand current 1 s, and 3 s	$I_{th}$	20 kA	20 kA	20 kA	16 kA	16 kA	16 kA
Rated making current	$I_{nk}$	-	50 kA	50 kA	-	40 kA	40 kA

Table 7

### 8.4 Processing time guide values

Mechanical switch-on delay (making time)	ms	40 <sup>1)</sup>
Mechanical switch off delay (breaking time)	ms	45 <sup>1)</sup>
Arc time (at 50 Hz)	ms	≤ 15
Total breaking time	ms	60 <sup>1)</sup>
Minimum command time when switching ON	ms	50 <sup>2)</sup>
Minimum command time when switching OFF	ms	50 <sup>2)</sup>

Table 8

1) rounded values

2) if the relay contact of the controlling device does not switch the tripping coil current off itself.

### 8.5 Release and blocking magnet

Device	Type designation	Power consumption <sup>1)</sup>	
		AC (V•A)	DC (W)
Breaking trip	Y2 and Y9	50	50
Making trip	Y3	130	80
Undervoltage release undelayed	Y4	40	-
Undervoltage release delayed	Y4	40	-
Transformer-operated trip	Y7	5	-

Table 9

1) rounded values

### 8.6 Motor winder

Rated AC voltage (V)	Power consumption (V•A)	Motor fuse (A)	max winding time at rated voltage (s)
110	80	1.60 S21 1K	6
220	80	0.75	6

Rated DC voltage (V)	Power consumption (W)	Motor fuse (A)	max winding time at rated voltage (s)
24	80	4.00 S21 2K	6
48	80	3.00	6
60	80	2.00	6
110	80	1.00	6
220	80	0.75	6

Table 10

### 8.7 Permissible number of operating cycles

Fig. 67 indicates the number of operating cycles of the circuit-breaker dependent upon the breaking current.

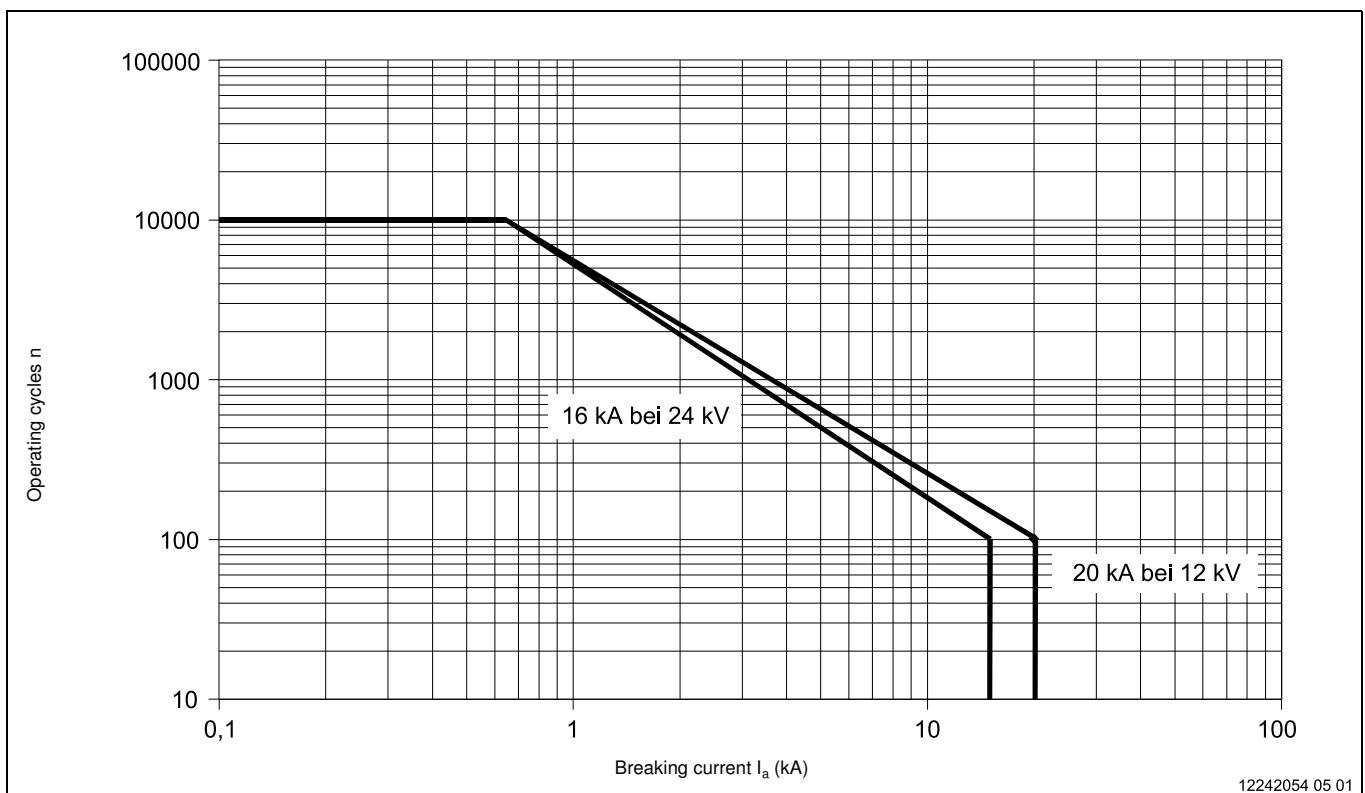

Fig. 67

## 8.8 Tightening torques

Thread nominal diameter	Screw joints strength class 8.8	Welded stud
M5	6 Nm	-
M6	10 Nm	5.9 Nm
M8	25 Nm	14.7 / -0.2 Nm
M10	49 Nm	-
M12	86 Nm	-

**Note!**

The table values do not apply for tightening torques specially mentioned in the documents!

Table 11

## 8.9 Materials

Metals	Steel, copper, aluminium, zinc
Plastic materials	PA, PE, PC, NBR, Q, EP, (PF/MF), BIIR, laminated fabric
Miscellaneous	Aluminium oxide, lubricants, SF <sub>6</sub> gas, oils, greases

Table 12

## 8.10 Auxiliary and operating materials for circuit-breakers

Application	Auxiliary and operating materials	Manufacturer
Bearing point lubrication	Rivolta SKD 4002	Bremer & Leguil GmbH Am Burgacker 30-42 47051 Duisburg
To refresh	Base oil for Rivolta	

Table 13

## 8.11 Regulations and standards

### 8.11.1 Test specifications

The circuit-breaker panel complies with the following VDE standards and/or IEC publications.

IEC 60265-1 (62271-103 <sup>1)</sup> )	/ VDE 0670 part 301 (VDE 0671 part 103 <sup>1)</sup> )
IEC 60529	/ VDE 0470 part 1
IEC 61243-5	/ VDE 0682 Part 415
IEC 62271-1 (60694) <sup>2)</sup>	/ VDE 0670 Part 1000 (VDE 0671 Part 1 <sup>1)</sup> )
IEC 62271-100	/ VDE 0671 part 100
IEC 62271-102	/ VDE 0671 part 102
IEC 62271-200 (60298 <sup>2)</sup> )	/ VDE 0671 part 200 (VDE 0670 part 6 <sup>2)</sup> )
IEC 62271-303 <sup>1)</sup>	/ VDE 0671 part 303 <sup>1)</sup>

DIN EN ISO 9001

BImSchV Federal Law Gazette 1996, part1 no. 66 dated 20.12.1996

<sup>1)</sup>Future

<sup>2)</sup>Former

### 8.11.2 Female connector (bushing)

Design of terminal components acc. to DIN EN 50181 connection type C (630 A) with external taper and screw contact M16.

## 9 Accessories

- Article no. 12244002 Assembly instructions, panel screw connection for extensible GAE630 panels
- Article no. 12238780 Assembly kit panel screw connection GAE-standard / GAE-standard
- Article no. 12238777 Assembly kit end panel
- Article no. 12238779 Extension kit end panel









**Ormazabal Anlagentechnik GmbH**

Am Neuerhof 31  
D-47804 Krefeld, Germany

Tel.: +49 2151 7151-0  
Fax: +49 2151 7151-75  
E-mail: [anlagentechnik@ormazabal.de](mailto:anlagentechnik@ormazabal.de)  
Internet: [www.ormazabal.de](http://www.ormazabal.de)