

BULDOZER CU ȘENILE

1150 L

SERIA - L



**PERFEȚIUNE
ÎN ORICE SITUAȚIE**

Experți în rezolvarea sarcinilor complexe
din 1842



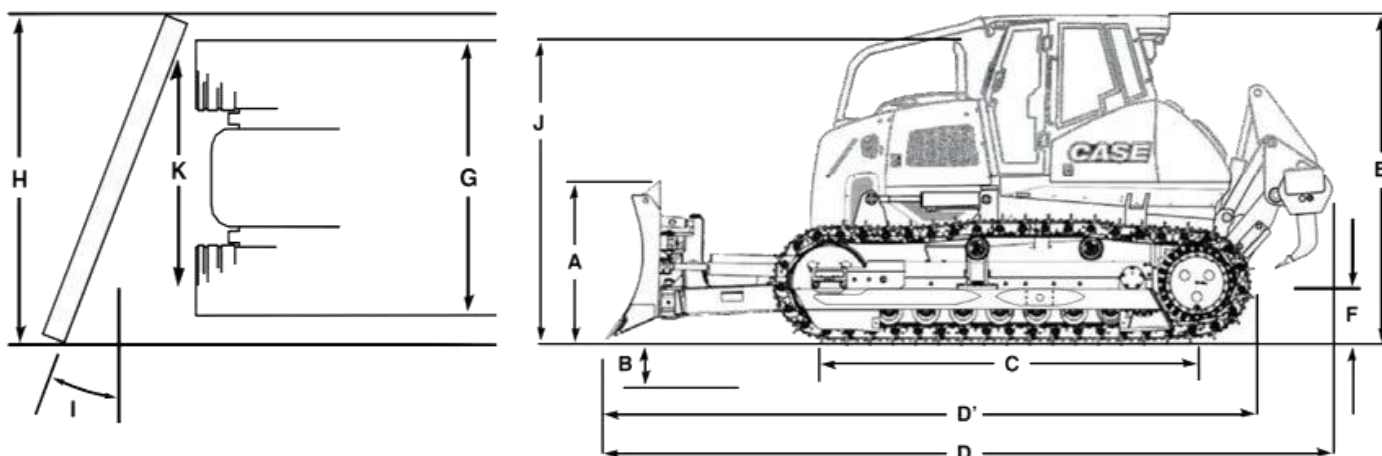

Dimensiuni

Înălțimea lamei	1200 mm
Adâncimea de scufundare a lamei	483 mm
Lungimea șenilelor pe sol	2590 mm
Lungime în poziție dreaptă cu lamă dreaptă și scarificator	5973
Lungime cu plug în poziție dreaptă și bară de remorcare	5025
Înălțimea până la partea superioară a cabinei	2829
Garda la sol	379 mm
Lățimea la marginile șenilelor	2286 mm
Lățime cu lama maxim extinsă	2787 mm
Lățimea lamei complet pe sol	3050
Unghiul de înclinare al lamei	250
Înălțimea la țeava de eșapament	2849
Lățimea ecartamentului șenilelor	1778
Lățimea șenilei	508 mm
Suprafața șenilelor pe sol	26323 cm ²
Presiune pe sol	0,47 kgf/cm ²
Capacitatea lamei	2,9 m ³
Ridicare plug deasupra solului	965 mm

XLT (Șenilă extinsă)

MOTOR

Model
 Număr cilindri
 Capacitate
 Injectare combustibil
 Filtru de combustibil
 Răcire
 Turații motor
 Turație fără sarcină
 Nume nominal - sarcină completă
 Rotație minimă
Putere conform SAE J1995 la 2200 rpm

CARACTERISTICI

FPT Industrial Engine F4HE9684K, certificat Tier 3
 6
 6,7 l
 Common rail
 Înșurubabil, cu sită
 Lichid
 R/min
 2200 +/- 50
 2200

Utilă Totală 800 +/- 25
 Lubrifiant motor 118 CP (88 kW)
 Unghiuri de lucru ale pompei 130 CP (97 kW)
 Transversale / longitudinale Forțată cu sistem de răcire a pistonului cu injectoare de ulei
 Radiator 450
 Suprafața de răcire 0,61 m
 Număr de rânduri de tuburi 4
 Ventilator
 Diametru 660
 Transmisie Cureaua mecanica

TRANSMISIE DE PUTERE

Hidrostatică, bidirecțională

Pompa
 Motor
Forța maximă de tracțiune

Axial-piston alternativ
 Axial-piston alternativ
 214 kN

Transmisie

Filtru de ulei

Viteze de deplasare

Înainte

Înapoi

Frână de staționare SAHR

Frână de mers

Reductor final

Soluție Transmisie

Un singur levier de comandă cu urmărire electronică a
 ii în linie dreaptă
 4 microni, înșurubabil, variabil

0-9,7 km/h

0-9,7 km/h

Se activează cu arc, se dezactivează hidraulic

Hidrostatic

2 angrenaje cu dinți oblici și reductor planetar

61,4:1

LAME

Înclinație reglabilă a lamei	55° - 60
Viteza de ridicare	483 mm/s
Muchie de tăiere	Reversibilă și schimbabilă
Lățime	203,2
Lungime	2158
Grosime	19,1

SISTEM HIDRAULIC

Debit pompa la 2200 rpm	132 l/min
Presiune max.	207 bar
Număr cilindri de ridicare a lamei cu rotire completă PAT	2
Diametrul canalului	108
Diametrul tijei	50,8mm
Cursă	445 mm
Număr cilindri de rotire a plugului complet rotativ RAT	2
Diametrul canalului	127mm
Diametrul tijei	63,5 mm
Cursă	381 mm
Număr cilindri de ridicare a plugului complet rotativ RAT	1
Diametrul canalului	127mm
Diametrul tijei	63,5 mm
Cursă	120mm

LOCUL DE MUNCĂ AL OPERATORULUI

- **Cabină ROPS\FOPS** cu aer condiționat, un joystick pentru viteză și direcție; scaun reglabil, cu suspensie pneumatică; centură de siguranță retractabilă de 50,8 mm; cotiere reglabile; două trepte; oglindă retrovizoare, trei ștergătoare de parbriz, lumină superioară, priză de 12 V; tavan moale; covorașe pe podea.

- Lămpi de semnalizare

Filtru de aer, generator, indicator de diagnosticare, temperatura lichidului de răcire; presiunea uleiului motorului; filtru hidraulic; nivel scăzut de combustibil, indicator de întreținere; filtru de transmisie; presiunea de încărcare în transmisie.

- Semnalele sonore

Temperatura lichidului de răcire al motorului, presiunea uleiului motorului; nivel scăzut de combustibil; temperatura uleiului sistemului hidraulic/hidrostatic.

- Indicatori

Tensiunea bateriei; nivelul combustibilului; contor de ore de funcționare \ tahometru \ diagnosticare \ memento de întreținere; temperatura uleiului de transmisie; indicator de viteză a transmisiei; temperatura lichidului de răcire. Case 1150L este dotat cu sistem de iluminare cu proiectoare de tip LED ,concepute pentru condiții de exploatare grele rezistente la apa si vibrații asigurând vizibilitatea optimă în timpul lucrării pe timp de noapte.

SISTEMUL DE TRANSMISIE

Tensiunea lanțului	Introducerea lubrifiantului
Cadru	Șasiu din două secțiuni fabricat din oțel de calitate
Pasul verigii șenilei	175,4 mm
Înălțimea patinei șenilei	51
Diametrul bolțului	36,6 mm
Diametrul bușei	62mm
Număr de zale pe o parte	43
Număr de role de sprijin pe o parte	7
Număr de role de susținere pe o parte	2
Diametrul rolor	190mm

SISTEM ELECTRIC

Generator	65A
Baterii(2)	2x12 V în serie, fără întreținere, 750 A CCA – la -18 °

MASA DE EXPLOATARE

Mașină cu cabină, rezervor plin, operator 77 kg, cârlig frontal, protecție pentrușenile, lamă rotativă completă PAT

Versiunea XLT (șasiu prelungit)
Greutate suplimentară

13.651kg

Placă de remorcare
Afanator

66 kg

1043 kg

Protecție pentru role

134 kg

Rezervor de combustibil

Rezervor de combustibil	300 l
Morot cu filtru	16,4 l
Motor fara filtru	15,6 l
Sistem de racire a motorului	25,5 l
Rezervor hidraulic	98,4 l
Transmisie finala lateral	14,2 l
Rola de sustinere	0,330 l
Roata de ghidare ,fiecare	0,460 l
Rola de sustinere ,fiecare	0,280 l

Teremen de garantie – 36 luni

Cu respect, Reprezentant oficial al CASE Construction, Polimer Gaz Conducte SRL
Cozer Constantin

INFO: www.pgc.md

TEL: +373 621 20 300

EMAIL: cozerconstantin7@gmail.com

CRAWLER DOZER XLT

CASE

CONSTRUCTION

SINCE 1842.

1150L

ENGINE

Brand	FPT
Model	F4HE9684K*J105
Type	Electronic, diesel, 4-stroke, direct injection, turbocharged, Tier 3 certified
Cylinders	6
Bore and stroke	4.09 x 5.2 in (104 x 132 mm)
Displacement	408.86 in ³ (6,7 l)
Direct injection	Common Rail
Fuel	Diesel
Fuel filter	Screw-on, with screen filter
Cooling System	Liquid
Engine rotations - rpm	
High - neutral without load	2,300 +/- 50
Nominal - full load	2,200
Low idle	1,000 +/- 100
Power @ 2,200 rpm - ISO 14396	
Gross (SAE J1349)	130 hp (97 kW)
Net (SAE J1349)	118 hp (88 kW)
Torque @ 1,400 rpm	
Gross	434.42 lbf.ft (589 Nm)
Net	418.56 lbf.ft (567,5 Nm)
Engine lubrication	"Forced lubrication" with oil jet piston refrigeration system
Operating angle	
Sideways	45°
Longitudinal	45°
Oil filter	Replaceable, screw-on, total flow cartridge
Radiator	
Fins per inch	6
Fan propeller	Belt mechanical drive Diameter 2 ft 2 in (662 mm)

POWER TRAIN

Hydrostatic system with closed circuit two stage	
Pump	Axial piston and variable flow
Engine	Axial piston and variable displacement
Maximum traction force	48,000 lb (213.5 kN)
Transmission	Commanded by a single electronically controlled lever
Oil filter	Replaceable cartridge with filtering up to 4 micron with a 100 mesh suction screen
Displacement speeds	
Forward	6.0 mph (9,7 km/h)
Reverse	6.0 mph (9,7 km/h)
Parking brake	SAHR (Applied through spring actuation, released hydraulically)
Steering brakes	Hydrostatic
Final command	2 helical gear reductions and a planetary reduction
Reduction ratio	61.4:1
Transmission cooling	
Type	Heat exchanger
Core area	844 in ² (5,445 cm ²)

NOTE: Measured using standard track chain. Increases travel speeds by 4% and reduces drawbar pull by 4% with the optional CELT track chain.

ELECTRIC SYSTEM

Alternator	65 A
Batteries	2x 12V in series, maintenance free 750 CCA @ -0.4°F
Voltage	24 V

HYDRAULIC SYSTEM

Pump flow @ 2,200 rpm with 2,830 psi (195 bar)	34.9 gpm (132 l/min)
PAT lifting cylinders	2
Diameter of the cylinder	4.25 in (108 mm)
Diameter of the cylinder rod	2 in (50,8 mm)
Stroke	1 ft 6 in (445 mm)
PAT blade angling cylinders	2
Diameter of the cylinder	5 in (127 mm)
Diameter of the cylinder rod	2.5 in (63,5 mm)
Stroke	1 ft 3 in (381 mm)
PAT inclination cylinder	1
Diameter of the cylinder	5 in (127 mm)
Diameter of the cylinder rod	2.5 in (63,5 mm)
Stroke	4.72 in (120 mm)

OPERATOR COMPARTMENT

Cab

Closed ROPS/FOPS compartment with air-conditioning
Single joystick for speed and direction
Adjustable seat upholstered with cloth and air suspension
Retractable seatbelt 2 in (50,8 mm)
Adjustable arm rests
Two foot rests
Rear view mirror
Three windshield wipers
A dome light
Connector for accessories 12 V
Padded roof
Floor mats

Warning lights

Air filter
Alternator
Failure diagnosis indicator
Engine cooling fluid temperature
Engine oil pressure
Hydraulic filter
Low fuel
Emergency brake on
Maintenance service indicator
Transmission filter
Transmission load pressure

Indicators

Battery voltage
Fuel level
Digital hour meter
Tachometer
Diagnosis
Service reminder
Transmission oil temperature
Transmission speed indicator
Cooling fluid temperature

Audible alarms

Engine cooling fluid temperature
Engine oil pressure
Low fuel
Hydraulic/hydrostatic system oil temperature

CAPACITIES

Fuel Tank	79 gal 1 qt (300 l)
Engine oil with filter	4 gal 1 qt (16,4 l)
Engine oil without filter	4 gal (15,6 l)
Engine cooling system	8 gal 2 qt (32,5 l)
Hydraulic tank	26 gal (98,4 l)
End reducer on each side	3 gal 3 qt (14,2 l)
Each lower roller	0,48 qt (450 ml)
Each idler	0,49 qt (460 ml)
Each upper roller	0,31 qt (290 ml)

OPERATING WEIGHT

Unit equipped with a cab, full fuel tank, 170 lb (77 kg) operator, frontal pull hook, track guides, PAT blade. 28,964 lb (13.138 kg)

VERSION XLT

Extra-long tracks	28.380 lb (12.873 kg)
Weights	
Drawbar	146 lb (66 kg)
Ripper	2,300 lb (1.043 kg)
Roller protection	295 lb (134 kg)

OTHER SPECIFICATIONS

UNDERCARRIAGE

Adjustment of tracks	Grease injection
Chassi	Two-tier and manufactured in structural steel
Length of the tracks on the ground	
XLT (Extra-long)	8' 6" (2.590 mm)
Track pitch	
Distance between the shoes	6.9" (175,4 mm)
Grouser height	2,25" (57,2 mm)
Pin diameter	1.44" (36,58 mm)
Bushing diameter	
CLT track (Case Lubrificated Track)	62 mm (2.44")
Number of shoes	43
Rollers	
Lower (each side)	7
Upper (each side)	2
Diameter of the lower rollers	7.5 in (190 mm)
Diameter of the upper rollers	5.5 in (140 mm)

TRACK AREA

Shoe width	1 ft 8 in (508 mm)
Track area on the ground	28.30 ft ² (2,63 m ²)

BLADE

Variable blade inclination	55° a 60°
Lifting speed	483 mm/seg (19 pol/sec)
Reversible and replaceable blade	
Width PAT	8 in (203,2 mm)
Thickness PAT	0,75 in (19,1 mm)
Legth	7 ft 1in (2158 mm)
Quantity	1

RIPPER

Maximum penetration	1' 7" (478 mm)
Width	5' 7" (1.712 mm)
Cutting width	5' 4" (1.636mm)
Maximum free space over the ground	10,3 in (262 mm)
Maximum number of teeth	3
Clearance between the teeth with 3 shanks	2' 7" (785 mm)
Double action hydraulic piston	
Diameter	4 in (101,6 mm)
Stroke	10" (254 mm)
Diameter of the rod	2" (50,8 mm)

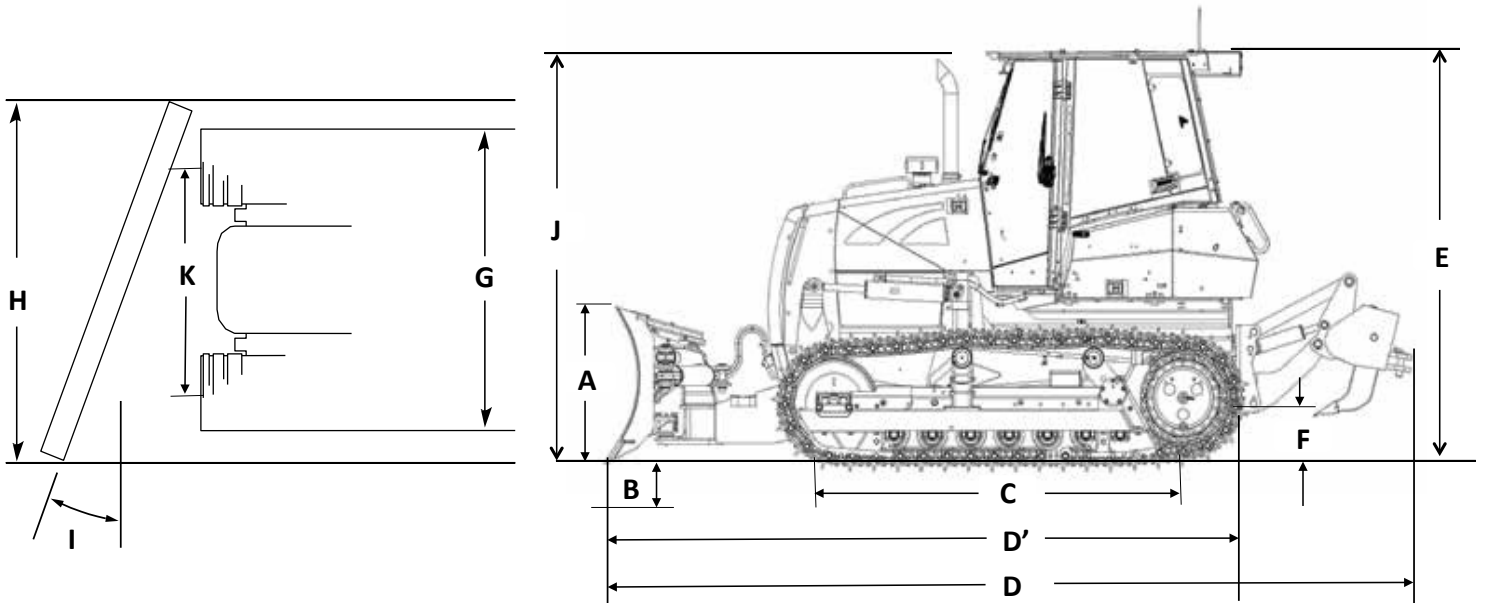

DIMENSIONS – PAT BLADE

XLT (extra-long track) PAT

A. Blade height	3' 8" (1.119 mm)
B. Depth of the blade in the ground	1' 7" (483 mm)
C. Length of the track on the ground	8' 6" (2.590 mm)
D. Length of the blade in the straight position and ripper	19' 7" (5.973 mm)
D'. With blade in the straight position and draw bar	15' 11" (4.856 mm)
E. Height of the top of the cab	9' 3" (2.829 mm)
F. Height above ground	1' 3" (379 mm)
G. Width to the ends of the tracks	7' 6" (2.286 mm)
H. Width of the blade at a maximum angle	9' 1" (2.770 mm)
Width of the blade fully placed on the ground	10' (3.050 mm)
I. Blade angle of attack	25°
J. Height of the exhaust	9' 4" (2.849 mm)
K. Track Gauge	5' 10" (1.780 mm)
Width of the shoe	1' 8" (508 mm)
Area of the track on the ground	28,30 ft ² (2,63 m ²)
Pressure on the ground	6.80 psi (46,9 kPa)
SAE blade capacity	3.76 yd ³ (2,9 m ³)
Elevation of the blade over the ground	3' 2" (965 mm)
Blade oscillation (up to 8.3°)	1' 5" (439 mm)

Figures are merely illustrative and may not be an exact representation of the unit.

STANDARD EQUIPMENT

Operator Compartment

See page 2

Engine

FPT F4HE9684K*J105
Fan belt automatic tensioner
Engine oil cooler
Fuel filter
Air filter with double element radial sealing
Turbine type pre-filter
65 A alternator
Battery (2) 12V 750 CCA
Cooling system with radiators protected against possible sand projection.
Excellent access for maintenance by panels on the sides of the engine.

Power Train

2-way closed circuit with automatic speed variation with hydrostatic drive and electric control that adjusts the power and speed independently for each tread while turning or counter-rotating.

Final commands

Triple reduction of final commands.
SAHR type parking brake (applied by spring and released by hydraulic pressure).

Blade

With manual inclination adjustment from 55° to 60°.
Blade control with a single lever (electric/hydraulic) on the right side of the operator, with infinitely variable positions to control the six blade functions (up, down, angled to the left and right, tilt to the left and right).

Tread train

Hydraulic adjustment of the tracks through grease injection.
CASE Lubricated Treads (CLT).
Sealed and lubricated pins, upper and lower rollers sealed and lubricated.
Front and rear track guides.

Ripper

3 teeth with 3 positions.

Others

Anti-vandalism package
Audible reverse gear warning
Horn
Work lights
2 frontal
1 rear
Master key
Internal mirror
Predisposition for the SiteWatch monitoring system
Frontal tow hook
Safety belt 2 in (50.8 mm)

OPTIONAL EQUIPMENT

Operator Compartment

Rear windshield wiper

Equipment mounted on the rear

Rear draw bar.

Others

Drains that protect the environment while changing fluids.
Intake air heater for ignition in cold climates.
Additional work lights totaling four in the front and two in the back.
Extended Duration Track (C.E.L.T)



Fleet monitoring and management system by satellite or cel phone tracking.

CASE Corporation reserves the right to make improvements in design or changes in specifications at any time without incurring any obligation to install them on units previously sold. The specifications, descriptions, and illustrative materials contained here reflect correctly the data known up to the publication date, but are subject to changes with no previous notice. The illustrations may include optional equipment and accessories and may not include all standard equipment.

CCEIO106 – 03/2022 – Printed in Brazil

CaseCE.com



Commercial Offices

ARGENTINA
Ávalos 2829 Edif. 1 Piso 4°,
Complejo Urbana
Vicente López (1605) Bs. As.,
Argentina.
Tel: +54 (11) 2034 1400

Manufacturing plants

Contagem – Minas Gerais – Brasil
Av. General David Sarnoff, 2.237
Inconfidentes – C.P. 32210-900
Tel.: +55 31 2104-3392

Sorocaba – São Paulo – Brasil
Av. Jerome Case, 1.801
Éden – C.P. 18087-220
Tel.: +55 15 3334-1700