

# POTATO PEELERS

## CONTENTS

---

<b>A</b>	<b>GENERAL INFORMATION</b> .....	<b>Page 2</b>
A1	PRODUCT DESCRIPTION .....	Page 3
A2	TECHNICAL INFORMATION .....	Page 4
A3	TRANSPORTATION .....	Page 5
A4	UNPACKING .....	Page 5
<b>B</b>	<b>INSTALLATION</b> .....	<b>Page 5</b>
<b>C</b>	<b>SAFETY INSTRUCTIONS</b> .....	<b>Page 6</b>
<b>D</b>	<b>OPERATION</b> .....	<b>Page 7</b>
<b>E</b>	<b>CLEANING &amp; MAINTENANCE</b> .....	<b>Page 8</b>
<b>F</b>	<b>TROUBLESHOOTING</b> .....	<b>Page 8</b>
<b>G</b>	<b>SPARE PART LIST- EXPLODING DRAWINGS</b> .....	<b>Page 9</b>
<b>H</b>	<b>ELECTRIC CIRCUIT SCHEMA</b> .....	<b>Page 25</b>

## A GENERAL INFORMATION

---

Before installing the appliance, read operation and maintenance instructions carefully. Wrong installation and part changing may damage the product or may cause injury on people. These are not in our company's responsibility to damage the appliance intentionally, negligence, detriments because of disobeying instructions and regulations, wrong connections. Unauthorized intervention to appliance invalidates the warranty.

1. This instruction manual should be kept in a safe place for future reference.
2. **Installation should be made in accordance with ordinances and security rules of that country by a qualified service personnel.**
3. This appliance has to be used by trained person.
4. Please turn off the appliance immediately in the event of malfunction or failure. The appliance should be repaired only by authorized service personnel. Please demand original spare part.

# POTATO PEELERS

## A1 PRODUCT DESCRIPTION

\*Professional Potato Peelers ,that provides high efficiency has been designed to be used in industrial kitchens.

Product Code	Dimensions (mm)	Weight (kg)	Packaging Dimensions (mm)
<b>PS.05</b>	540X760X965	42	600X840X1140
<b>PS.06</b>	540X760X965	42	600X840X1140
<b>PS.07</b>	600X870X1065	53	660X900X1220
<b>PS.08</b>	600X870X1065	53	660X900X1220
<b>PS.09</b>	600X870X1160	58	700X950X1300
<b>PS.10</b>	<b>600X870X1160</b>	<b>58</b>	<b>700X950X1300</b>
<b>PS.05-F</b>	490X780X1210	55	600X840X1390
<b>PS.06-F</b>	490X780X1210	55	600X840X1350
<b>PS.07-F</b>	590X880X1310	75	660X900X1480
<b>PS.08-F</b>	590X880X1310	75	660X900X1480
<b>PS.09-F</b>	590X880X1400	80	700X950X1580
<b>PS.10-F</b>	590X880X1400	80	700X950X1580

**A2 TECHNICAL INFORMATION**

Product Code	Capacity (kg)	Tank Dimensions (mm)	Power (Kw)	Operating Voltage (V)	Cable (mm <sup>2</sup> )	Fuse (A)
PS.05	10	400x380	0,55	220-380	3x1,5	20
PS.06	10	400x380	0,55	220-380	5x1,5	25
PS.07	20	500x400	0,75	220-380	3x1,5	20
PS.08	20	500x400	0,75	220-380	5x1,5	25
PS.09	30	500x500	1,5	220	3x1,5	20
<b>PS.10</b>	<b>30</b>	<b>500x500</b>	<b>1,1</b>	<b>380</b>	<b>5x1,5</b>	<b>25</b>
PS.05-F	10	400x380	0,55	220-380	3x1,5	20
PS.06-F	10	400x380	0,55	220-380	5x1,5	25
PS.07-F	20	500x400	0,75	220-380	3x1,5	20
PS.08-F	20	500x400	0,75	220-380	5x1,5	25
PS.09-F	30	500x500	1,5	220	3x1,5	20
PS.10-F	30	500x500	1,1	380	5x1,5	25

## POTATO PEELERS

### A3 TRANSPORTATION

---

\*This appliance can not be moved by hand from area to area. It must be moved on pallet with forklift truck.

### A4 UNPACKING

---

\*Please unpack the package according to the security codes and ordinances of current country and get rid from the pack. Parts which contacts with food are produced by stainless steel. All plastic parts are marked by material's symbol.

\*Please check that all the parts of appliance had come completely and if they are damaged or not during the shipping.

### B INSTALLATION

---

\*Please place the product to straight and sturdy ground, please take necessary steps against possibility of overturn.

\*Technician who will serve for installation and service for the appliance must be professional on this subject and must have installation and service licenses by the company.

\*Connection to Electric Power Supply must be done by authorized person.

\*Please be sure that the voltage connected to appliance must be equal with the voltage which is on appliance's label.









 This appliance must be connected to an earthed outlet in accordance with safety rules and standards.

\*Appliance's earthing must be connected to earthing line on panel which is nearest to electric installation.

\*Connection to the main fuse and leak current fuse must be done in accordance with the current regulations.

**C SAFETY INSTRUCTIONS**

---

-  \*Do not use the appliance in insufficient lighted place.
-  \*Do not touch the moving attachments while the appliance operates.
-  \*Do not install the appliance in the presence of flammable or explosive materials.
-  \*Do not operate the appliance when the machine is empty.
-  \*Do not load so less or more than appliance's capacity.
-  \*Do not attempt to use the appliance without suitable protective equipments.
-  \*Because of any reason if there is a fire or flame flare where the appliance is used, turn off all gas valves and electric contactor switch quickly and use fire extinguisher. Never use water to extinguish the fire.
-  \*All the damages because of not having earthing connection will not be on warranty.
-  \*Upper lid mustn't be opened while appliance is operating. Otherwise potatoes may be thrown out.

# POTATO PEELERS

## D OPERATION

### \*Control Panel;

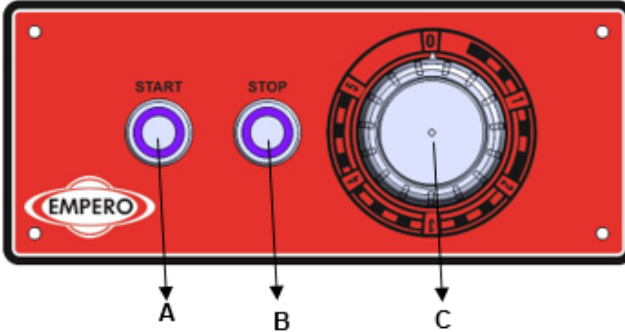

**A:** START Button  
**B:** STOP Button  
**C:** Timer Setting

### \*Operating;

- Clean the appliance by operating it with water in it when it is empty .Then operate the appliance.
- Pre-Cleaning of potatoes that will be put into appliance must be done ( earth,mud ).
- Put potatoes as tank capacity.
- Open the water entrance valve that comes to tank.
- Be sure that upper lid of tank must be closed and lid latch must be locked.
- Press START button to operate the appliance.
- If the appliance operates with 380 V,while plugging during first operation ,pay attention to be operated on the direction of arrow.
- Set the appliance's operating time by pressing timer setting buttons.Potato peeling time is 1-2 min.When time expires the appliance will stop.If the appliance is operated more than necessity it may be disrupted.
- If it is wanted to take off the products while the appliance is operating ; Open the front lid and take off the products by keeping your hand pressed on START button.
- After the operation completed,unplug the power supply.

## E CLEANING & MAINTENANCE

### ➤ CLEANING AND MAINTENANCE AFTER EVERY USE

- After every potato peeling process, clean the inside of tank and lower drum. Clean and dry until there is no residue of potato.
- Always turn off the appliance and disconnect from the power supply before cleaning.
- Clean outer surface of appliance and tank lid with wet cloth and then dry.
- Do not use abrasive cleaning chemicals as these can leave harmful residues.
- Do not clean the appliance by spraying water directly, otherwise electric motor may get damaged.

### ➤ PERIODIC CLEANING AND MAINTENANCE

- Get the periodic maintenance of the appliance once in every 15 days.
- Maintenance should be done by qualified person.
- The Potato Peeler requires low maintenance (Motor and ball bearings are lubricated).
- Maintenance of appliance's contactor should be done by compressed air according to frequency of use.

## F TROUBLESHOOTING

<b>THE APPLIANCE DOESN'T OPERATE</b>	<ol style="list-style-type: none"> <li>1. Check if the appliance is plugged in.</li> <li>2. Check the electrical connections and voltage.</li> <li>3. While evacuating the product from front lid, the appliance is not operated.</li> </ol>
<b>THE APPLIANCE IS NOISY</b>	<ol style="list-style-type: none"> <li>1. Check that if there is material accumulated in the tank or not.</li> <li>2. If the motor is noisy, stop it and call authorized service.</li> </ol>
<b>THE APPLIANCE STOPPED</b>	<ol style="list-style-type: none"> <li>1. The appliance can stop due to low voltage. In this situation check the voltage.</li> <li>2. The appliance may stop when it is overloaded. In this situation allow the motor to cool by taking off some materials from tank.</li> </ol>
<b>ERROR MESSAGE</b>	<b>E1</b> : Thermic error.

- If Potato peeling is not done at suitable quality
- If any function of security doesn't work
  - Do not use the appliance.

**\*If these problems are still going on, contact with our authorized service.**



# POTATO PEELERS

## G SPARE PART LIST-EXPLODING DRAWING

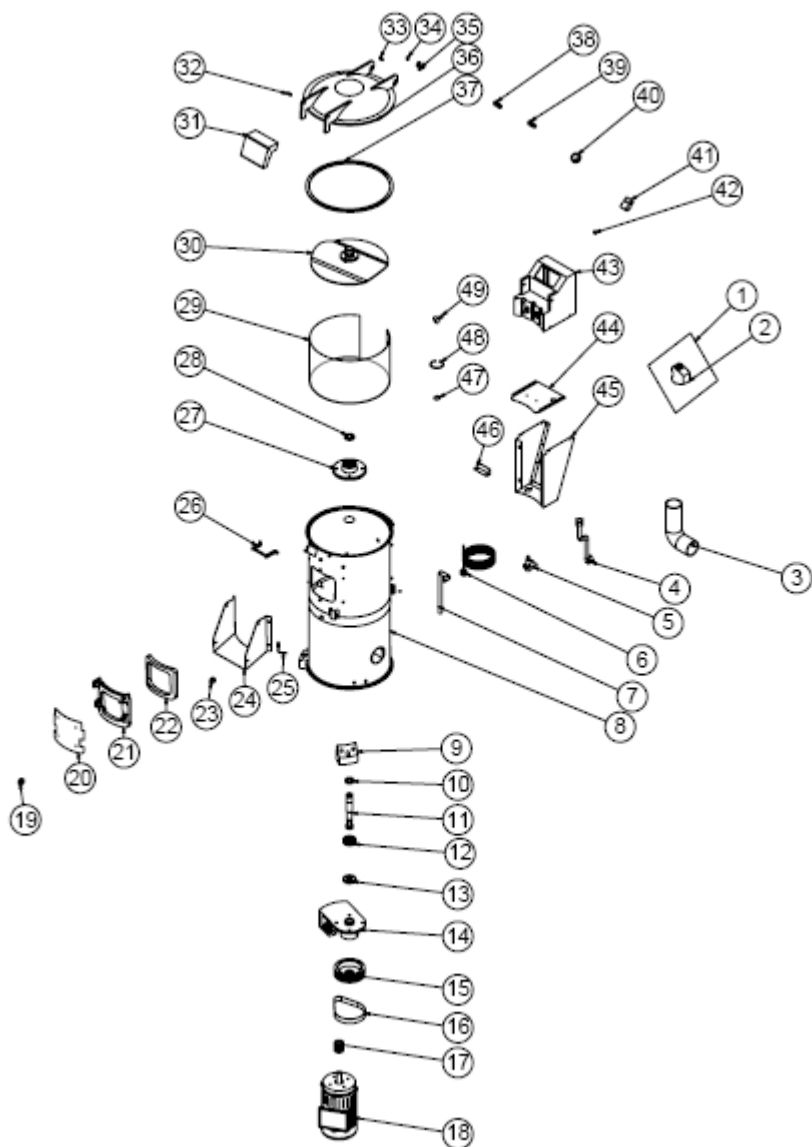

PS.05

**G SPARE PART LIST-EXPLODING DRAWING**

PRODUCT CODE: PS.05		
NO	PRODUCT NAME	P.CODE
1	PANEL GROUP	M.ELK-PNO-PS-001
2	CONTACTOR LC1K0910M	ERS.M.ELK-KNT-KNT-021
3	DRAIN HOSE	ERS.M.MEK-TE5-HRT-010
4	HOSE 150CM	ERS.M.MEK-TE5-HRT-011
5	VALVE	M.ELK-SLN-PLS-005
6	3*1,5 CABLE	M.ELK-PWR-PBK-003
7	WELDING HOSE	HTS-HRT-003
8	CHASSIS	-
9	FOOT	M.AKS-AYK-PLS-003
10	FELT 25*62*8	M.CNT-KCE-034
11	ENGINE SLEEVE SHAFT	YTL-ERS.PS-KS-0010
12	BEARING ( 6305 ZZ )	M.RLM-NRM-009
13	FELT 25*62*8	M.CNT-KCE-005
14	ENGINE PLATE	YDK-ERS.PS-CN-0001
15	SLEEVE PULLEY	YDK-ERS.PS-CN-0009
16	11 PJ 559 STRAP	M.KYS-TKY-002
17	ENGINE PULLEY	YTL-ERS.PS-KS-0026
18	ELECTRIC MOTOR	M.ELK-MTR-RSM-002
19	COVER PLASTIC	YTL-ERS.PS-KS-0020
20	COVER FRONT SHEET	YSC-ERS.PS-LZ-0030
21	COVER PLASTIC	M.ENJ-ERS-PLS-PS-015
22	COVER GASKET	M.CNT-ERS-026
23	ECCENTRIC WHEEL	YTL-ERS.PS-KS-0021
24	COVER BODY SHEET	YSC-ERS.PS-LZ-0026
25	MAGNETIC SENSOR	M.ELK-SWC-KTG-001
26	COVER HINGE SHAFT	YTL-ERS.PS-KS-0005
27	ENGINE SLEEVE	YDK-ERS.PS-CN-0004
28	FELT 30*42*7	M.CNT-KCE-033
29	EMERY	ARA-ERS.PS-0005
30	DRUM	ARA-ERS.PS-0003
31	COVER LATCH	M.ENJ-ERS-PLS-PS-002
32	COVER LATCH PIN	YTL-ERS.PS-KS-0003
33	TOP COVER PIN	YTL-ERS.PS-KS-0004
34	MAGNET	M.MIK-ERS-002
35	MAGNET SHEET	YSC-ERS.PS-LZ-0003
36	COVER PLASTIC	M.ENJ-ERS-PLS-PS-001
37	U WICK	HCN-LAS-ERS-001
38	RED BUTTON (MOMENTARY)	M.ELK-SLT-BTL-010
39	GREEN LIGHTED BUTTON	ERS.M.ELK-SLT-BTL-011
40	BUTTON	M.ENJ-ERS-PLS-PS-018
41	TIME CLOCK	M.ELK-MEK-MTM-003
42	MAGNET	M.MIK-ERS-003
43	PANEL PLASTIC	M.ENJ-ERS-PLS-PS-003
44	PANEL METAL SHEET	YSC-ERS.PS-LZ-0025
45	PANEL SHEET	YSC-ERS.PS-LZ-0036
46	PANEL ADDITIONAL SHEET	YSC-ERS.PS-LZ-0024
47	RING 471-25	B-SEG-SYH-005
48	RING 472-62	B-SEG-SYH-004
49	WATER SPRAY	YTL-ERS.PS-KS-0016



## G SPARE PART LIST-EXPLODING DRAWING

PRODUCT CODE : PS.06		
NO	PRODUCT NAME	P.CODE
1	PANEL GROUP	M.FLK-PNO-PS-002
2	CONTACTOR LC1K0910M	FRS.M.FLK-KNT-KNT-021
3	2*0.75 MM CABLE	HFL-KB-TT-2*0.75-BYZ
4	HOSE 150CM	FRS.M.MEK-TFS-HRT-011
5	VALVE	M.FLK-SLN-PLS-005
6	WELDING HOSE	HTS-HRT-003
7	PG-13.5 CABLE FITTING	M.FLK-RKR-PLS-007
8	DRAIN HOSE	FRS.M.MEK-TFS-HRT-010
9	FOOT	M.AKS-AYK-PLS-003
10	CHASSIS	-
11	STAMP	B-WPI-SYH-071-004
12	ENGINE SLEEVE SHAFT	YTL-FRS.PS-KS-0010
13	ENGINE PLATE	YDK-FRS.PS-CN-0001
14	FFLT 25*62*8	M.CNT-KCF-034
15	ENGINE FLANGE SHEET	YSC-FRS.SD-IZ-0030
16	SLEEVE PULLEY	YDK-FRS.PS-CN-0009
17	11 PI 559 STRAP	M.KYS-TKY-002
18	ELECTRIC MOTOR	M.FLK-MTR-RSM-003
19	ENGINE PULLEY	YTL-FRS.PS-KS-0025
20	FFLT 25*62*8	M.CNT-KCF-005
21	BEARING ( 6305 ZZ )	M.RIM-NRM-009
22	BUSH	YBR-FRS.PS-KS-0001
23	COVER PLASTIC	YTL-FRS.PS-KS-0020
24	ECCENTRIC WHEEL	YTL-FRS.PS-KS-0021
25	COVER PLASTIC	M.FNI-FRS-PLS-PS-015
26	COVER FRONT SHEET	YSC-FRS.PS-IZ-0030
27	COVER GASKET	M.CNT-FRS-026
28	COVER BODY SHEET	YSC-FRS.PS-IZ-0026
29	COVER HINGE SHAFT	YTL-FRS.PS-KS-0005
30	MAGNETIC SENSOR	M.FLK-SWC-KTG-001
31	ENGINE SLEEVE	YDK-FRS.PS-CN-0004
32	DRUM	ARA-FRS.PS-0003
33	FMERY	ARA-FRS.PS-0005
34	U WICK	HCN-IAS-FRS-001
35	COVER LATCH PIN	YTL-FRS.PS-KS-0003
36	COVER LATCH	M.FNI-FRS-PLS-PS-002
37	COVER PLASTIC	M.FNI-FRS-PLS-PS-001
38	TOP COVER PIN	YTL-FRS.PS-KS-0004
39	MAGNET	M.MIK-FRS-002
40	MAGNET	M.MIK-FRS-003
41	MAGNET SHEET	YSC-FRS.PS-IZ-0003
42	TIME CLOCK	M.FLK-MEK-MTM-003
43	RED BUTTON (MOMENTARY)	M.FLK-SLT-BTL-010
44	GREEN LIGHTED BUTTON	FRS.M.FLK-SLT-BTL-011
45	BUTTON	M.FNI-FRS-PLS-PS-018
46	PANEL PLASTIC	M.FNI-FRS-PLS-PS-003
47	PANEL METAL SHEET	YSC-FRS.PS-IZ-0025
48	PANEL SHEET	YSC-FRS.PS-IZ-0036
49	PANEL BACK SHEET	YSC-FRS.PS-IZ-0037
50	RING 471-25	B-SFG-SYH-005
51	RING 472-62	B-SFG-SYH-004
52	WATER SPRAY	YTL-FRS.PS-KS-0016

# POTATO PEELERS

## G SPARE PART LIST-EXPLODING DRAWING

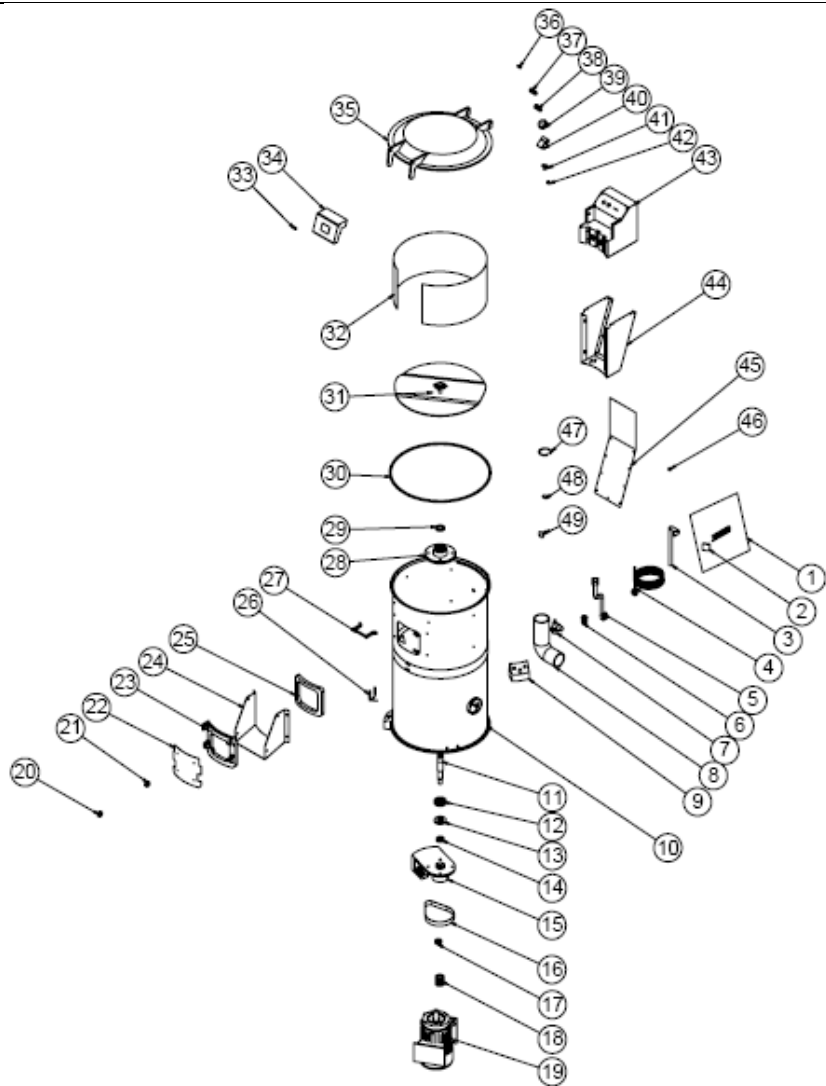

## G SPARE PART LIST-EXPLODING DRAWING

PRODUCT CODE : PS.07		
NO	PRODUCT NAME	P.CODE
1	PANEL GROUP	M.ELK-PNO-PS-001
2	CONTACTOR LC1K0910M	ERS.M.ELK-KNT-KNT-021
3	WELDING HOSE	HTS-HRT-003
4	3*1.5 CABLE	M.ELK-PWR-PBK-003
5	HOSE 150CM	ERS.M.MEK-TE5-HRT-011
6	PG-13.5 CABLE FITTING	M.ELK-RKR-PLS-007
7	VALVE	M.ELK-SLN-PLS-005
8	DRAIN HOSE	ERS.M.MEK-TE5-HRT-010
9	FOOT	M.AKS-AYK-PLS-003
10	CHASSIS	-
11	ENGINE SLEEVE SHAFT	YTL-ERS.PS-KS-0010
12	BEARING ( 6305 ZZ )	M.RIM-NRM-009
13	FELT 25*62*8	M.CNT-KCF-005
14	FELT 25*62*8	M.CNT-KCF-034
15	ENGINE PLATE	YDK-ERS.PS-CN-0001
16	11 PJ 559 STRAP	M.KYS-TKY-002
17	BUSH	YBR-ERS.PS-KS-0001
18	ENGINE PULLEY	YTL-ERS.PS-KS-0026
19	ELECTRIC MOTOR	M.ELK-MTR-RSM-005
20	ECCENTRIC WHEEL	YTL-ERS.PS-KS-0021
21	COVER PLASTIC	YTL-ERS.PS-KS-0020
22	COVER FRONT SHEET	YSC-ERS.PS-LZ-0030
23	COVER PLASTIC	M.ENJ-ERS-PLS-PS-016
24	COVER BODY SHEET	YSC-ERS.PS-LZ-0029
25	COVER GASKET	M.CNT-ERS-027
26	MAGNETIC SENSOR	M.ELK-SWC-KTG-001
27	COVER HINGE SHAFT	YTL-ERS.PS-KS-0005
28	ENGINE SLEEVE	YDK-ERS.PS-CN-0004
29	FELT 30*42*7	M.CNT-KCF-033
30	U WICK	HCN-LAS-ERS-002
31	DRUM	ARA-ERS.PS-0002
32	EMERY	ARA-ERS.PS-0006
33	COVER LATCH PIN	YTL-ERS.PS-KS-0003
34	COVER LATCH	M.ENJ-ERS-PLS-PS-002
35	COVER PLASTIC	M.ENJ-ERS-PLS-PS-007
36	TOP COVER PIN	YTL-ERS.PS-KS-0004
37	RED BUTTON (MOMENTARY)	M.ELK-SLT-BTL-010
38	GREEN LIGHTED BUTTON	ERS.M.ELK-SLT-BTL-011
39	BUTTON	M.ENJ-ERS-PLS-PS-018
40	TIME CLOCK	M.ELK-MEK-MTM-003
41	MAGNET SHEET	YSC-ERS.PS-LZ-0003
42	MAGNET	M.MIK-ERS-002
43	PANEL PLASTIC	M.ENJ-ERS-PLS-PS-003
44	PANEL SHEET	YSC-ERS.PS-LZ-0036
45	PANEL BACK SHEET	YSC-ERS.PS-LZ-0037
46	MAGNET	M.MIK-ERS-003
47	RING 472-62	B-SEG-SYH-004
48	RING 471-25	B-SEG-SYH-005
49	WATER SPRAY	YTL-ERS.PS-KS-0016

# POTATO PEELERS

## G SPARE PART LIST-EXPLODING DRAWING

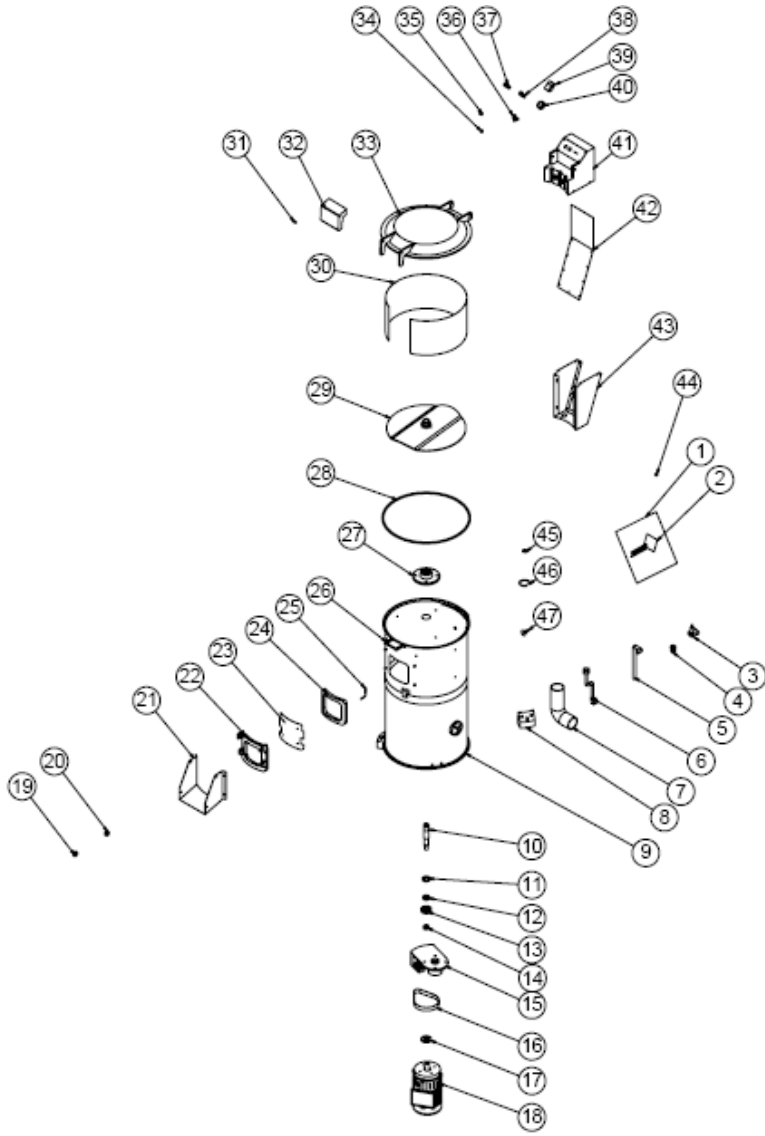

## G SPARE PART LIST-EXPLODING DRAWING

PRODUCT CODE : PS.08		
NO	PRODUCT NAME	P.CODE
1	PANEL GROUP	M.ELK-PNO-PS-002
2	CONTACTOR LC1K0910M	ERS.M.ELK-KNT-KNT-021
3	VALVE	M.ELK-SLN-PLS-005
4	PG-13,5 CABLE FITTING	M.ELK-RKR-PLS-007
5	WELDING HOSE	HTS-HRT-003
6	HOSE 150CM	ERS.M.MEK-TES-HRT-011
7	DRAIN HOSE	ERS.M.MEK-TES-HRT-010
8	FOOT	M.AKS-AYK-PLS-003
9	CHASSIS	-
10	ENGINE SLEEVE SHAFT	YTL-ERS.PS-KS-0010
11	FELT 30*42*7	M.CNT-KCE-033
12	FELT 25*62*8	M.CNT-KCE-034
13	BEARING ( 6305 ZZ )	M.RLM-NRM-009
14	BUSH	YBR-ERS.PS-KS-0001
15	ENGINE PLATE	YDK-ERS.PS-CN-0001
16	11 PJ 559 STRAP	M.KYS-TKY-002
17	FELT 25*62*8	M.CNT-KCE-005
18	ELECTRIC MOTOR	M.ELK-MTR-RSM-006
19	ECCENTRIC WHEEL	YTL-ERS.PS-KS-0021
20	COVER PLASTIC	YTL-ERS.PS-KS-0020
21	COVER BODY SHEET	YSC-ERS.PS-LZ-0029
22	COVER PLASTIC	M.ENJ-ERS-PLS-PS-016
23	COVER FRONT SHEET	YSC-ERS.PS-LZ-0030
24	COVER GASKET	M.CNT-ERS-027
25	MAGNETIC SENSOR	M.ELK-SWC-KTG-001
26	COVER HINGE SHAFT	YTL-ERS.PS-KS-0005
27	ENGINE SLEEVE	YDK-ERS.PS-CN-0004
28	U WICK	HCN-LAS-ERS-002
29	DRUM	ARA-ERS.PS-0002
30	EMERY	ARA-ERS.PS-0006
31	COVER LATCH PIN	YTL-ERS.PS-KS-0003
32	COVER LATCH	M.ENJ-ERS-PLS-PS-002
33	COVER PLASTIC	M.ENJ-ERS-PLS-PS-007
34	MAGNET	M.MIK-ERS-002
35	TOP COVER PIN	YTL-ERS.PS-KS-0004
36	BUSH	YTL-ERS.PS-KS-0011
37	RED BUTTON (MOMENTARY)	M.ELK-SLT-BTL-010
38	GREEN LIGHTED BUTTON	ERS.M.ELK-SLT-BTL-011
39	TIME CLOCK	M.ELK-MEK-MTM-003
40	BUTTON	M.ENJ-ERS-PLS-PS-018
41	PANEL PLASTIC	M.ENJ-ERS-PLS-PS-003
42	PANEL BACK SHEET	YSC-ERS.PS-LZ-0037
43	PANEL SHEET	YSC-ERS.PS-LZ-0036
44	MAGNET	M.MIK-ERS-003
45	RING 471-25	B-SEG-SYH-005
46	RING 472-62	B-SEG-SYH-004
47	WATER SPRAY	YTL-ERS.PS-KS-0016



# POTATO PEELERS

## G SPARE PART LIST-EXPLODING DRAWING

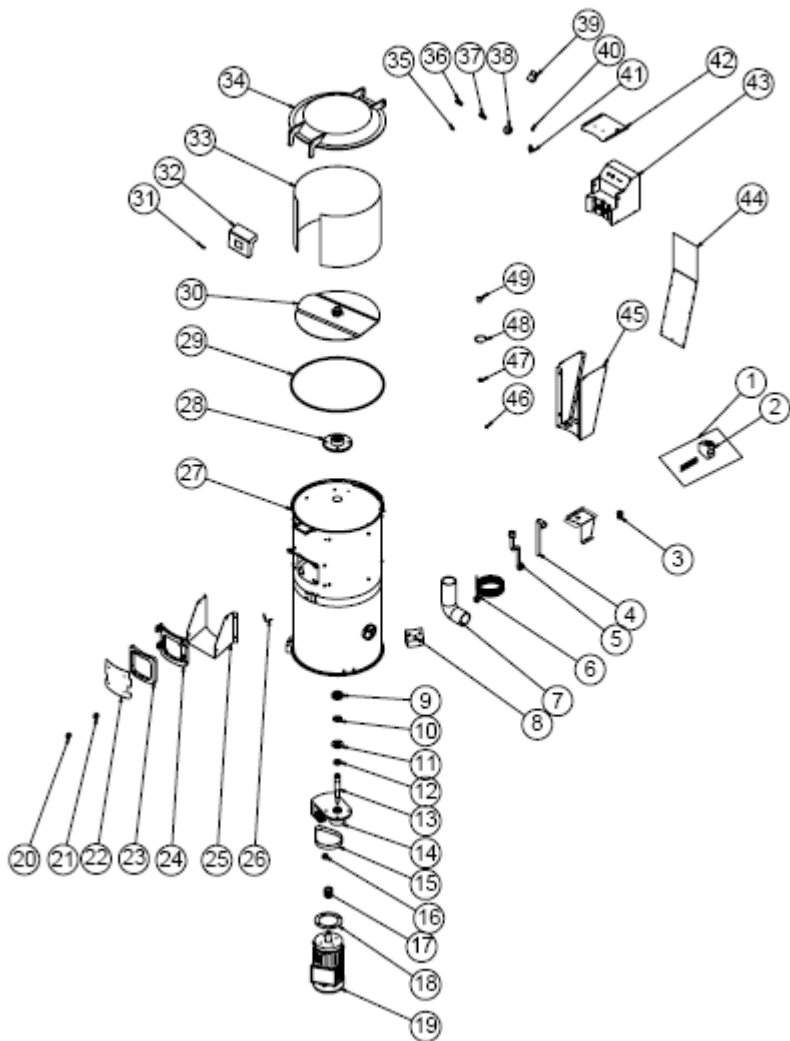

PS.09

## G SPARE PART LIST-EXPLODING DRAWING

PRODUCT CODE :PS.09		
NO	PRODUCT NAME	P.CODE
1	PANEL GROUP	M.ELK-PNO-PS-001
2	CONTACTOR LC1K0910M	ERS.M.ELK-KNT-KNT-021
3	PG-13,5 CABLE FITTING	M.ELK-RKR-PLS-007
4	WELDING HOSE	HTS-HRT-003
5	HOSE 150CM	ERS.M.MEK-TES-HRT-011
6	3*1,5 CABLE	M.ELK-PWR-PBK-003
7	DRAIN HOSE	ERS.M.MEK-TES-HRT-010
8	FOOT	M.AKS-AYK-PLS-003
9	BEARING ( 6305 ZZ )	M.RLM-NRM-009
10	FELT 30*42*7	M.CNT-KCE-033
11	FELT 25*62*8	M.CNT-KCE-005
12	FELT 25*62*8	M.CNT-KCE-034
13	ENGINE SLEEVE SHAFT	YTL-ERS.PS-KS-0010
14	ENGINE PLATE	YDK-ERS.PS-CN-0001
15	11 PJ 559 STRAP	M.KYS-TKY-002
16	BUSH	YBR-ERS.PS-KS-0001
17	ENGINE PULLEY	YTL-ERS.PS-KS-0024
18	ENGINE FLANGE	YSC-ERS.PS-LZ-0032
19	ELECTRIC MOTOR	M.ELK-MTR-RSM-010
20	ECCENTRIC WHEEL	YTL-ERS.PS-KS-0021
21	COVER PLASTIC	YTL-ERS.PS-KS-0020
22	COVER FRONT SHEET	YSC-ERS.PS-LZ-0030
23	COVER GASKET	M.CNT-ERS-027
24	COVER PLASTIC	M.ENJ-ERS-PLS-PS-016
25	COVER BODY SHEET	YSC-ERS.PS-LZ-0029
26	MAGNETIC SENSOR	M.ELK-SWC-KTG-001
27	CHASSIS	-
28	ENGINE SLEEVE	YDK-ERS.PS-CN-0004
29	U WICK	HCN-LAS-ERS-002
30	DRUM	ARA-ERS.PS-0002
31	COVER LATCH PIN	YTL-ERS.PS-KS-0003
32	COVER LATCH	M.ENJ-ERS-PLS-PS-002
33	EMERY	ARA-ERS.PS-0007
34	COVER PLASTIC	M.ENJ-ERS-PLS-PS-007
35	TOP COVER PIN	YTL-ERS.PS-KS-0004
36	RED BUTTON (MOMENTARY)	M.ELK-SLT-BTL-010
37	GREEN LIGHTED BUTTON	ERS.M.ELK-SLT-BTL-011
38	BUTTON	M.ENJ-ERS-PLS-PS-018
39	TIME CLOCK	M.ELK-MEK-MTM-003
40	MAGNET	M.MIK-ERS-002
41	MAGNET SHEET	YSC-ERS.PS-LZ-0003
42	PANEL METAL SHEET	YSC-ERS.PS-LZ-0025
43	PANEL PLASTIC	M.ENJ-ERS-PLS-PS-003
44	PANEL BACK SHEET	YSC-ERS.PS-LZ-0035
45	PANEL SHEET	YSC-ERS.PS-LZ-0034
46	MAGNET	M.MIK-ERS-003
47	RING 471-25	B-SEG-SYH-005
48	RING 472-62	B-SEG-SYH-004
49	WATER SPRAY	YTL-ERS.PS-KS-0016

# POTATO PEELERS

## G SPARE PART LIST-EXPLODING DRAWING

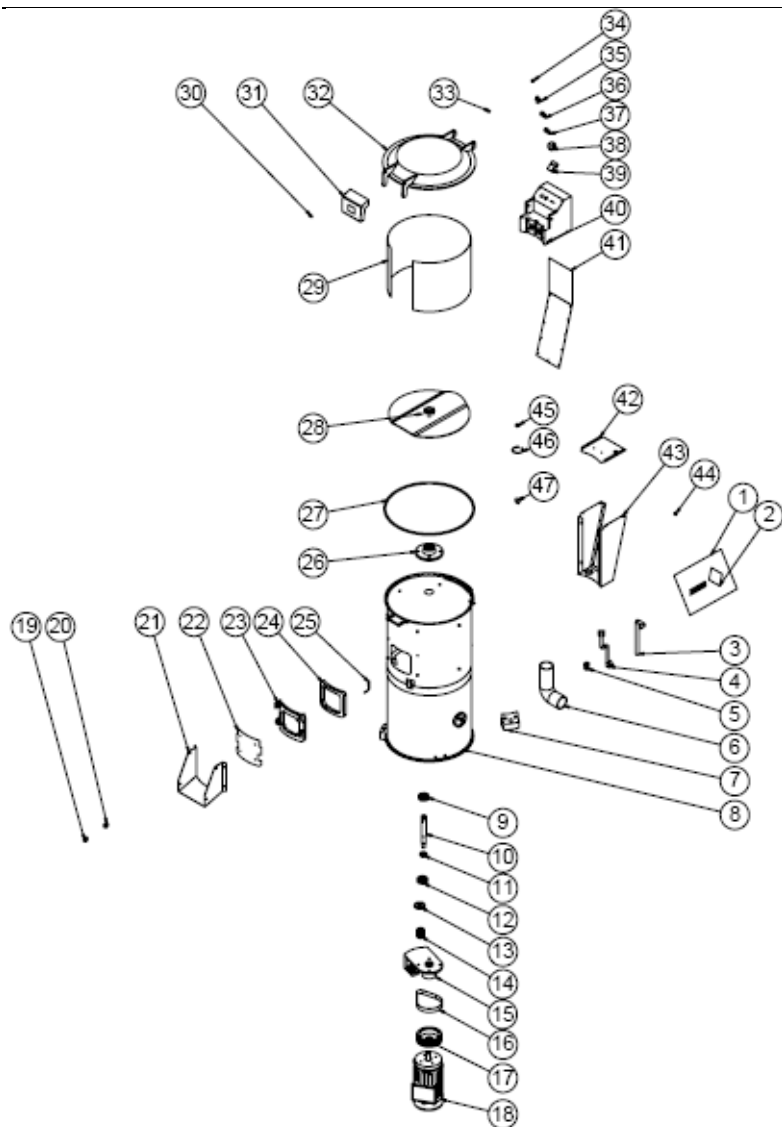

## G SPARE PART LIST-EXPLODING DRAWING

PRODUCT CODE : PS.10		
NO	PRODUCT NAME	P.CODE
1	PANEL GROUP	M.ELK-PNO-PS-002
2	CONTACTOR LC1K0910M	ERS.M.ELK-KNT-KNT-021
3	WELDING HOSE	HTS-HRT-003
4	HOSE 150CM	ERS.M.MEK-TES-HRT-011
5	PG-13.5 CABLE FITTING	M.ELK-RKR-PLS-007
6	DRAIN HOSE	ERS.M.MEK-TES-HRT-010
7	FOOT	M.AKS-AYK-PLS-003
8	CHASSIS	-
9	BEARING ( 6305 ZZ )	M.RLM-NRM-009
10	ENGINE SLEEVE SHAFT	YTL-ERS.PS-KS-0013
11	FELT 25*62*8	M.CNT-KCE-034
12	FELT 30*42*7	M.CNT-KCE-033
13	FELT 25*62*8	M.CNT-KCE-005
14	ENGINE PULLEY	YTL-ERS.PS-KS-0026
15	ENGINE PLATE	YDK-ERS.PS-CN-0001
16	11 PJ 559 STRAP	M.KYS-TKY-002
17	SLEEVE PULLEY	YDK-ERS.PS-CN-0009
18	ELECTRIC MOTOR	M.ELK-MTR-RSM-011
19	ECCENTRIC WHEEL	YTL-ERS.PS-KS-0021
20	COVER PLASTIC	YTL-ERS.PS-KS-0020
21	COVER BODY SHEET	YSC-ERS.PS-LZ-0029
22	COVER FRONT SHEET	YSC-ERS.PS-LZ-0030
23	COVER PLASTIC	M.ENJ-ERS-PLS-PS-016
24	COVER GASKET	M.CNT-ERS-027
25	MAGNETIC SENSOR	M.ELK-SWC-KTG-001
26	ENGINE SLEEVE	YDK-ERS.PS-CN-0004
27	U WICK	HCN-LAS-ERS-002
28	DRUM	ARA-ERS.PS-0002
29	EMERY	ARA-ERS.PS-0007
30	COVER LATCH PIN	YTL-ERS.PS-KS-0003
31	COVER LATCH	M.ENJ-ERS-PLS-PS-002
32	COVER PLASTIC	M.ENJ-ERS-PLS-PS-007
33	TOP COVER PIN	YTL-ERS.PS-KS-0004
34	MAGNET	M.MIK-ERS-002
35	MAGNET SHEET	YSC-ERS.PS-LZ-0003
36	RED BUTTON (MOMENTARY)	M.ELK-SLT-BTL-010
37	GREEN LIGHTED BUTTON	ERS.M.ELK-SLT-BTL-011
38	BUTTON	M.ENJ-ERS-PLS-PS-018
39	TIME CLOCK	M.ELK-MEK-MTM-003
40	PANEL PLASTIC	M.ENJ-ERS-PLS-PS-003
41	PANEL BACK SHEET	YSC-ERS.PS-LZ-0035
42	PANEL METAL SHEET	YSC-ERS.PS-LZ-0025
43	PANEL SHEET	YSC-ERS.PS-LZ-0034
44	MAGNET	M.MIK-ERS-003
45	RING 471-25	B-SEG-SYH-005
46	RING 472-62	B-SEG-SYH-004
47	WATER SPRAY	YTL-ERS.PS-KS-0016

# POTATO PEELERS

## G SPARE PART LIST-EXPLODING DRAWING

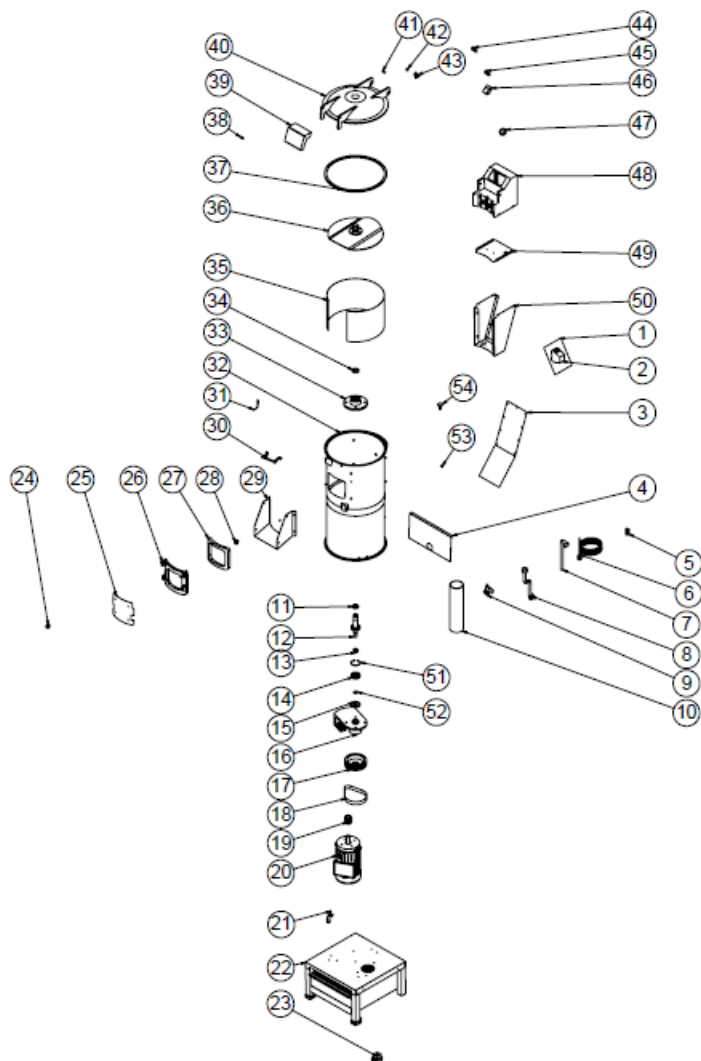

PS.05-F / PS.06-F

## G SPARE PART LIST-EXPLODING DRAWING

PRODUCT CODE : PS.05-F / PS.06-F		
NO	PRODUCT NAME	P.CODE
1	PANEL GROUP	M.ELK-PNO-PS-001
2	MINI CONTRACTOR	M.ELK-KNT-KNT-021
3	PANEL BACK SHEET	YSC-ERS.PS-LZ-0037
4	LOWER BOILER REAR SHEET	YSC-ERS.PS-LZ-0020
5	CABLE RACK	M.ELK-RKR-PLS-007
6	3*1.5 TTR GRAY CABLE WITH PLUG 3 MT - PS.05-F	M.ELK-PWR-PBK-003
6	2*0.75 MM DUAL CORD CABLE - PS.06-F	HEL-KB-TT-2*0.75-BYZ
7	OXYGEN WELDING HOSE	HTS-HRT-003
8	MAINS HOSE	M.MEK-TES-HRT-011
9	VENTIL	M.ELK-SLN-PLS-005
10	DRAIN HOSE	M.MEK-TES-HRT-035
11	30X40X10 CHROME SPRING SEAL	M.CNT-KCE-034
12	MOTOR SLEEVE SHAFT	YTL-ERS.PS-KS-0010
13	HIVE INTERMEDIATE SIGN	YBR-ERS.PS-KS-0001
14	(6305 Z) BEARING	M.RLM-NRM-009
15	25X62X8 SEAL	M.CNT-KCE-005
16	ENGINE TABLE	YDK-ERS.PS-CN-0001
17	SEWER CASNAGI	YDK-ERS.PS-CN-0009
18	TRIGGER BELT	M.KYS-TKY-002
19	MOTOR PULLEY	YTL-ERS.PS-KS-0026
20	ELECTRIC MOTOR - PS.05-F	M.ELK-MTR-RSM-002
20	ELECTRIC MOTOR - PS.06-F	M.ELK-MTR-RSM-003
21	CONNECTION	YSC-ERS.PS-LZ-0011
22	FILTER CHASSIS	-
23	FOOT	M.ENJ-ERS-LST-043
24	COVER PLASTIC	YTL-ERS.PS-KS-0020
25	COVER FRONT SHEET	YSC-ERS.PS-LZ-0027
26	COVER SPACER PLASTIC	M.ENJ-ERS-PLS-PS-015
27	COVER GASKET	M.CNT-ERS-026
28	COVER ECCENTRIC WHEEL	YTL-ERS.PS-KS-0021
29	COVER BODY SHEET	YSC-ERS.PS-LZ-0026
30	HINGE SHAFT	YTL-ERS.PS-KS-0005
31	MAGNETIC SENSOR	M.ELK-SWC-KTG-001
32	CHASSIS	-
33	ENGINE COVER	YDK-ERS.PS-CN-0004
34	30X47X7 - CHROME SPRING SEAL	M.CNT-KCE-033
35	SIDE PUMPING	HMH-ERS-005
36	DRUM ARAMON (SPARE PARTS)	ARA-ERS.PS-0003
37	THICK TIRE FILAMENT	HCN-LAS-ERS-001
38	COVER LATCH PIN	YTL-ERS.PS-KS-0003
39	COVER LATCH	M.ENJ-ERS-PLS-PS-002
40	BOILER COVER PLASTIC	M.ENJ-ERS-PLS-PS-001
41	TOP COVER PIN	YTL-ERS.PS-KS-0004
42	DIAMETER 13*10 - MIKNATIS	M.MIK-ERS-002
43	MIKNATIS HAIR	YSC-ERS.PS-LZ-0003
44	RED ILLUMINATED BUTTON (STOP)	M.ELK-SLT-BTL-010
45	GREEN LIGHT BUTTON (START)	M.ELK-SLT-BTL-011
46	5 MINUTE MECHANICAL WINDING TIME CLOCK	M.ELK-MEK-MTM-003
47	BUTTON	M.ENJ-ERS-PLS-PS-018
48	PANEL PLASTIC	M.ENJ-ERS-PLS-PS-003
49	PANEL INTERIOR SHEET	YSC-ERS.PS-LZ-0025
50	PANEL SHEET	YSC-ERS.PS-LZ-0036
51	SEGMAN (472-62)	B-SEG-SYH-004
52	PISTON RING (471-25)	B-SEG-SYH-005
53	DIAMETER 10*5 -MIKNATIS	M.MIK-ERS-003
54	WATER SPRINKLER	YTL-ERS.PS-KS-0016

# POTATO PEELERS

## G SPARE PART LIST-EXPLODING DRAWING

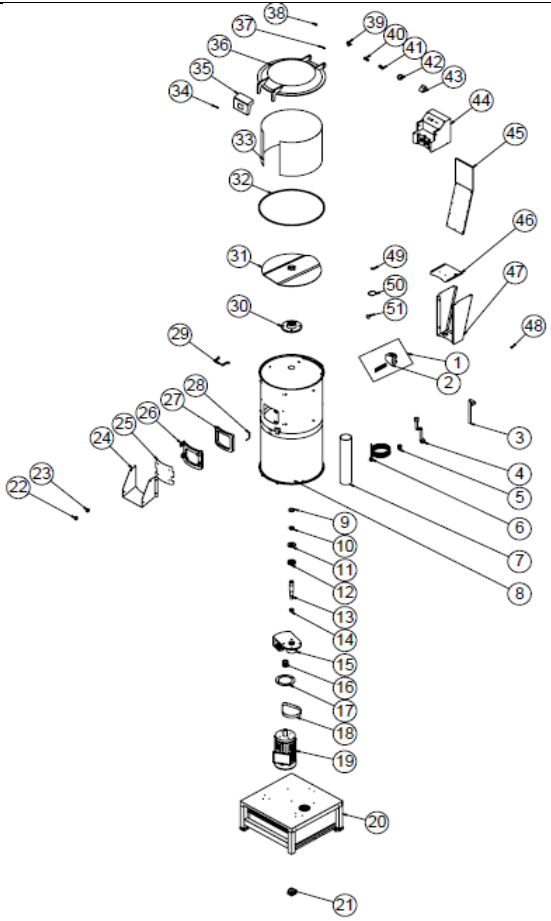

PRODUCT CODE : PS.07-F / PS.08-F / PS.09-F / PS.10-F		
NO	PRODUCT NAME	P.CODE
1	PANO GRUBU – PS.08-F	M.ELK-PNO-PS-001
1	PANO GRUBU PS.08-F	M.ELK-PNO-PS-002
1	PANO GRUBU PS.09-F	M.ELK-PNO-PS-001
1	PANO GRUBU PS.10-F	M.ELK-PNO-PS-002
2	KONTAKTÖR LC1K0910M	ERS.M.ELK-KNT-KNT-021
3	KAYNAK HORTUMU	HTS-HRT-003
4	HORTUM (150 CM)	ERS.M.MEK-TES-HRT-011
5	PG-13,5 KABLO RAKORU	M.ELK-RKR-PLS-007
6	KABLO PS.07-F	M.ELK-PWR-PBK-003

6	KABLO PS.08-F	HEL-KB-TT-2*0,75-BYZ
6	KABLO PS.09-F	M.ELK-PWR-PBK-003
6	KABLO PS.10-F	HEL-KB-TT-2*0,75-BYZ
7	TAHLİYE HORTUMU	M.MEK-TEŞ-HRT-036
8	ŞASE	-
9	KEÇE 25*62*8	M.CNT-KCE-005
10	KEÇE 30*47*7	M.CNT-KCE-033
11	KEÇE 30*40*10	M.CNT-KCE-034
12	RULMAN (6305 ZZ)	M.RLM-NRM-009
13	MOTOR KOVAN MİLİ	YTL-ERS.PS-KS-0010
14	BURÇ	YBR-ERS.PS-KS-0001
15	MOTOR TABLASI	YDK-ERS.PS-CN-0001
16	MOTOR KASNAĞI	YTL-ERS.PS-KS-0024
17	MOTOR FLANŞI	YSC-ERS.PS-LZ-0032
18	11 PJ 559 KAYIS	M.KYS-TKY-002
19	ELEKTRİK MOTORU – PS.07-F	M.ELK-MTR-RSM-005
19	ELEKTRİK MOTORU – PS.08-F	M.ELK-MTR-RSM-006
19	ELEKTRİK MOTORU – PS.09-F	M.ELK-MTR-RSM-010
19	ELEKTRİK MOTORU – PS.10-F	M.ELK-MTR-RSM-011
20	FİLTRE ŞASE	-
21	AYAK	M.ENJ-ERS-LST-043
22	EKSANTRİK TEKERİ	YTL-ERS.PS-KS-0021
23	KAPAK PLASTİĞİ	YTL-ERS.PS-KS-0020
24	KAPAK GÖVDE SACI	YSC-ERS.PS-LZ-0029
25	KAPAK ÖN SACI	YSC-ERS.PS-LZ-0030
26	KAPAK PLASTİĞİ	M.ENJ-ERS-PLS-PS-016
27	KAPAK CONTASI	M.CNT-ERS-027
28	MANYETİK SENSÖR	M.ELK-SWC-KTG-001
29	KAPAK MENTEŞE MİLİ	YTL-ERS.PS-KS-0005
30	MOTOR KOVANI	YDK-ERS.PS-CN-0004
31	TAMBUR	ARA-ERS.PS-0002
32	U FİTİL	HCN-LAS-ERS-002
33	ZIMPARA	ARA-ERS.PS-0006
33	ZIMPARA – PS.09-F	HMH-ERS-011
34	KAPAK MANDAL PİMİ	YTL-ERS.PS-KS-0003
35	KAPAK MANDALI	M.ENJ-ERS-PLS-PS-002
36	KAPAK PLASTİK	M.ENJ-ERS-PLS-PS-007
37	ÜST KAPAK PİMİ	YTL-ERS.PS-KS-0004
38	MIKNATIS	M.MIK-ERS-002
39	BURÇ	YTL-ERS.PS-KS-0011
40	KIRMIZI DÜĞME (ANLIK)	M.ELK-SLT-BTL-010
41	YEŞİL IŞIKLI DÜĞME	ERS.M.ELK-SLT-BTL-011
42	DÜĞME	M.ENJ-ERS-PLS-PS-018
43	ZAMAN SAATI (5 DAKİKA)	M.ELK-MEK-MTM-003
44	PANO PLASTİĞİ	M.ENJ-ERS-PLS-PS-003
45	PANO ARKA SACI	YSC-ERS.PS-LZ-0035
46	PANO ARA SACI	YSC-ERS.PS-LZ-0025
47	PANO SACI	YSC-ERS.PS-LZ-0034
48	MIKNATIS	M.MIK-ERS-003
49	SEGMAN (471-25)	B-SEG-SYH-005
50	SEGMAN (472-62)	B-SEG-SYH-004
51	SU FİSKİYESİ	YTL-ERS.PS-KS-0016



# POTATO PEELERS

## H ELECTRIC CIRCUIT SCHEMA

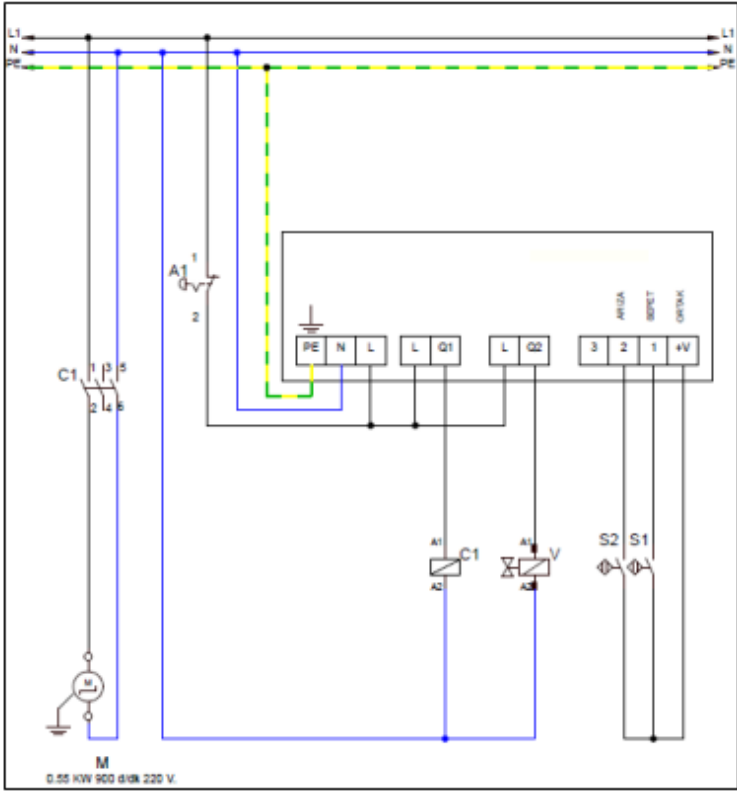

PRODUCT CODE	POWER (Kw)	RPM	VOLTAGE
PS.05 / PS.05-F	0,55	900	220 / 380
PS.07 / PS.07-F	0,75	900	220 / 380
PS.09 / PS.09-F	1,5	900	220

I	C1	Q1	S1	S2	X
Terminal	Contactor	Motor Safety Relay	Upper Lid Magnetic Sensor	Front Lid Magnetic Sensor	Control Panel

## H ELECTRIC CIRCUIT SCHEMA

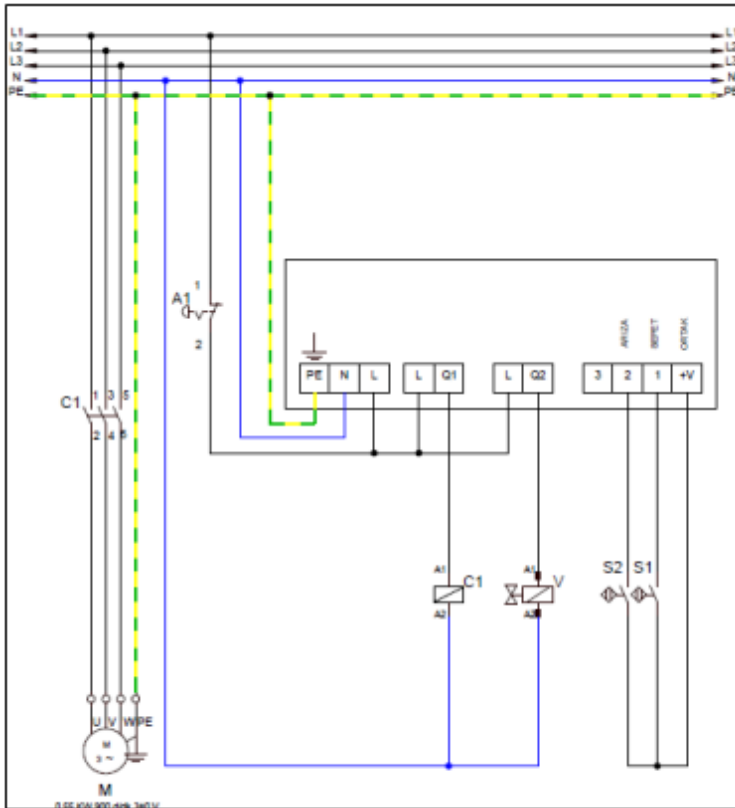

PRODUCT CODE	POWER (Kw)	RPM	VOLTAGE
PS.06 / PS.06-F	0,55	900	220 / 380
PS.08 / PS.08-F	0,75	900	220 / 380
<b>PS.10 / PS.10-F</b>	<b>1,1</b>	<b>900</b>	<b>380</b>

I	C1	Q1	S1	S2	X
Terminal	Contactor	Motor Safety Relay	Upper Lid Magnetic Sensor	Front Lid Magnetic Sensor	Control Panel