

EC Certificate Full Quality Assurance System: Certificate BG19/871871

The management system of

VISARIS Ltd.

Batajnički drum 10, deo 1b, 11080 Belgrade, Serbia

has been assessed and certified as meeting the requirements of

Directive 93/42/EEC on medical devices, Annex II (excluding Section 4)

For the following products

Visaris Avanse family of digital x-ray diagnostic imaging systems

Visaris PACS (Picture Archiving and Communication system)

Diagon (Medical imaging diagnostic workstation)

Vision family of X-ray systems (ddRAura Series)

Where the above scope includes class III medical device(s), a valid EC Design Examination Certificate according to Annex II (Section 4) is a mandatory requirement for each device in addition to this certificate to place that device on the market.

This certificate is valid from 16 December 2019 until 17 August 2023 and remains valid subject to satisfactory surveillance audits.
Issue 1. Certified since 17 August 2006 and first certified by SGS Belgium NV since 16 December 2019.

Certification is based on reports numbered BG/SOF 213593

Authorised by

SGS Belgium NV, Notified Body 1639

SGS House Noorderlaan 87 2030 Antwerp Belgium
t +32 (0)3 545-48-48 f +32 (0)3 545-48-49 www.sgs.com

LPMD5007 - Certificate CE1639 Annex II-4_EN rev. 02

Page 1 of 1

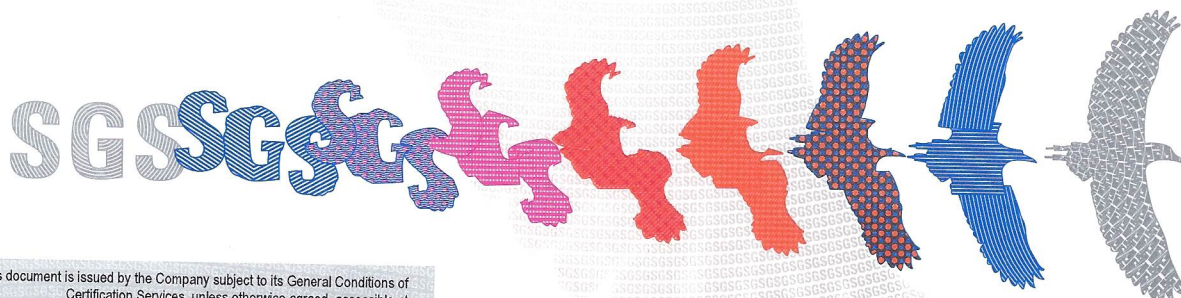

This document is issued by the Company subject to its General Conditions of Certification Services, unless otherwise agreed, accessible at www.sgs.com/terms_and_conditions.htm. Attention is drawn to the limitations of liability, indemnification and jurisdictional issues established therein. The authenticity of this document may be verified at <https://www.sgs.com/en/certified-clients-and-products/certified-client-directory>. Any unauthorized alteration, forgery or falsification of the content or appearance of this document is unlawful and offenders may be prosecuted to the fullest extent of the law.



World Registrar Group



ATC

08-019

СЕРТИФИКАЦИОНО
ТЕЛО-
СИСТЕМ МЕНАЏМЕНТА
ISO/IEC 17021-1

CERTIFICATE

Certification body World Registrar Group Europe d.o.o. attests that

VISARIS d.o.o.

Batajnicket drum 10. deo 1B, 11080 Zemun, Republic of Serbia

With scope of:

**Design, Manufacture, Installation, Service and Sales of Diagnostic X-ray Systems and
Medical Software Imaging Systems; Software Development**

Has established Quality Management System.

Based on the report No. 230221 - Q confirmed that the requirements of the standard have been fulfilled

ISO 9001:2015

The scope of the certification includes a management system applied at one location.

World Registrar Group

Certificate registration number: **Q02-2103VI/1**

Date of certification: **March 06, 2021**

Date of change: **October 08, 2021**

Certificate expiration date: **March 05, 2024**

The certificate is only valid after annual conducted surveillance audit with positive outcome

World Registrar Groupe Europe d.o.o. * Koste Abrasevica 27/2 * 11050 Belgrade * Republic of Serbia

Phone / Fax: +381 11 3678505 * office@wrgeuro.com

www.wrg.rs

Paul M Andre, Certification Director



World Registrar Group



ATC
08-019

СЕРТИФИКАЦИОНО
ТЕЛО-
СИСТЕМ МЕНАДЖМЕНТА
ISO/IEC 17021-1

SERTIFIKAT

Sertifikaciono telo World Registrar Group Europe d.o.o. potvrđuje da je organizacija

VISARIS d.o.o.

Batajnički drum 10. deo 1B, 11080 Zemun, Republika Srbija

Za predmet i područje sertifikacije:

Projektovanje, razvoj, proizvodnja, instalacija, servis i prodaja dijagnostičkih radioloških sistema i medicinskih softverskih sistema za vizuelizaciju; Razvoj softvera

uvela i primenjuje sistem menadžmenta kvalitetom.

Na osnovu izveštaja br. 230221 - Q potvrđeno je da su ispunjeni zahtevi standarda

SRPS ISO 9001:2015

Obim sertifikacije obuhvata sistem menadžmenta primenjen na jednoj lokaciji.

World Registrar Group

Registracioni broj sertifikata: **Q02 - 2103VI/1**

Datum sertifikacije: **06. Mart 2021**

Datum izmene: **08. Oktobar 2021**

Datum isticanja važnosti sertifikata: **05. Mart 2024**

Sertifikat je isključivo važeći uz obavljanje redovnih godišnjih nedzornih provera sa pozitivnim ishodom

World Registrar Groupe Europe d.o.o. * Koste Abraševića 27/2 * 11050 Beograd * Republika Srbija

Tel / Fax +381 11 3678505 * office@wrgeuro.com

www.wrg.rs

Paul M Andre, Direktor sertifikacije

Certificate BG06/67067

The management system of

VISARIS doo

Batajnički drum 10. deo 1b, 11080 Belgrade, Serbia

has been assessed and certified as meeting the requirements of

ISO 13485:2016 EN ISO 13485:2016

For the following activities

**Design, manufacture and sales of diagnostic X-ray systems,
and medical imaging systems.**

This certificate is valid from 01 September 2021 until 17 August 2024
and remains valid subject to satisfactory surveillance audits.
Recertification audit due a minimum of 60 days before the expiration date
Issue 5. Certified since 12 January 2006

*Expiry date of last certificate: 17 August 2021
End date of last recertification audit: 22 July 2021*

Authorised by

SGS United Kingdom Ltd
Rossmore Business Park Ellesmere Port Cheshire CH65 3EN UK
t +44 (0)151 350-6666 f +44 (0)151 350-6600 www.sgs.com

21HC 13485 2016 0421

Page 1 of 1



0005

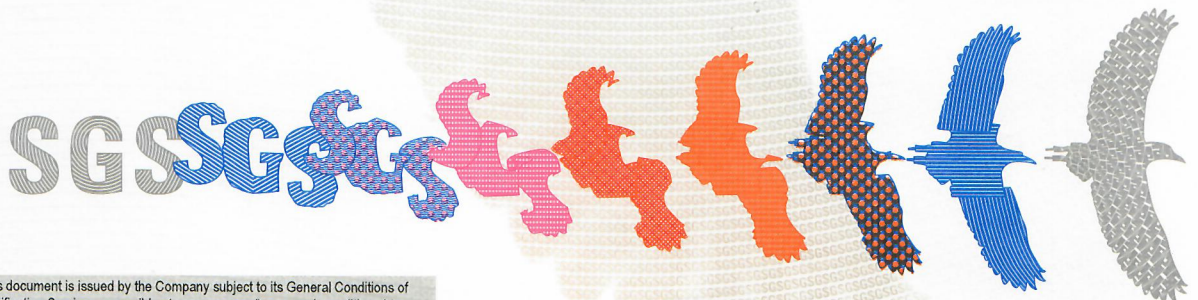



VISARIS

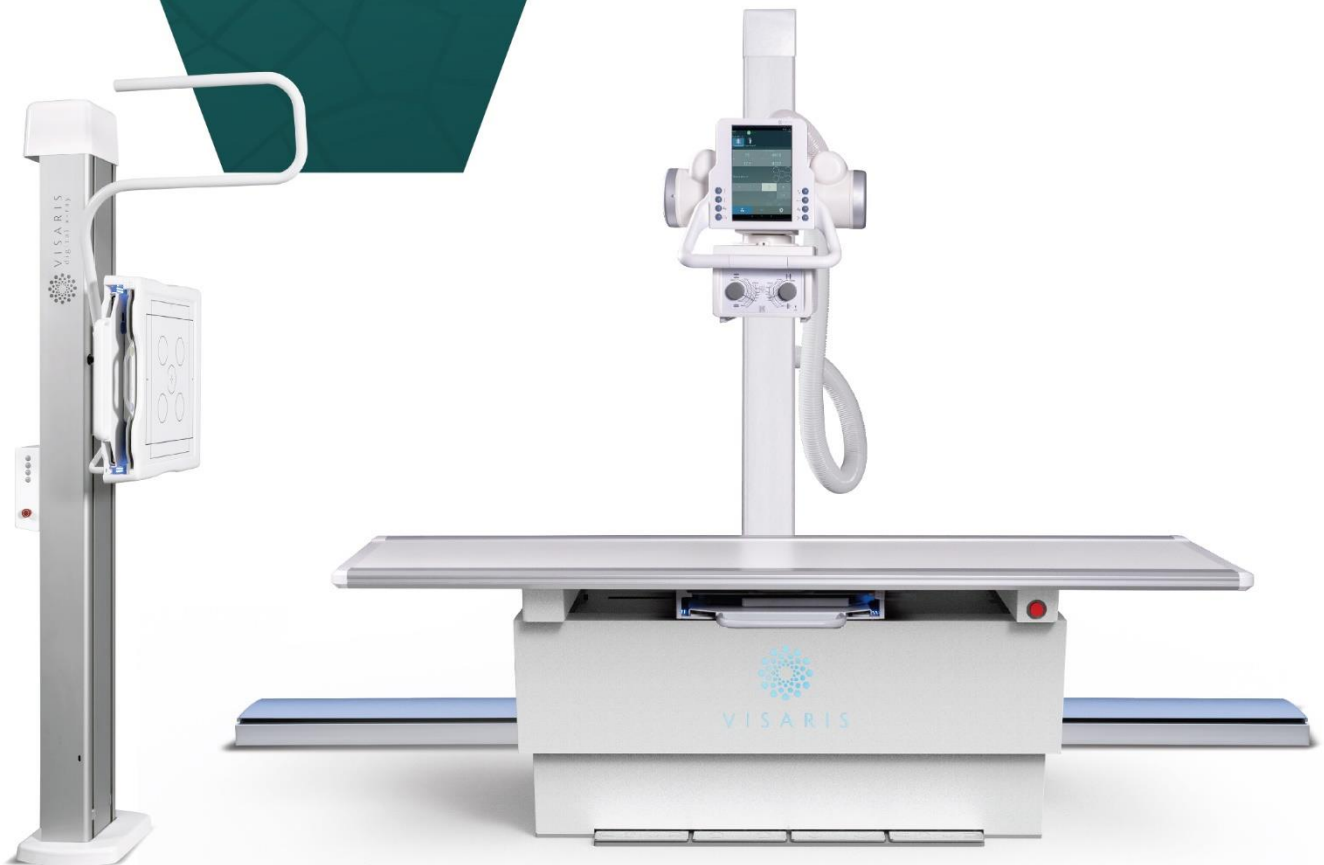

V3.0 August 2021

VISION V

Sales Book

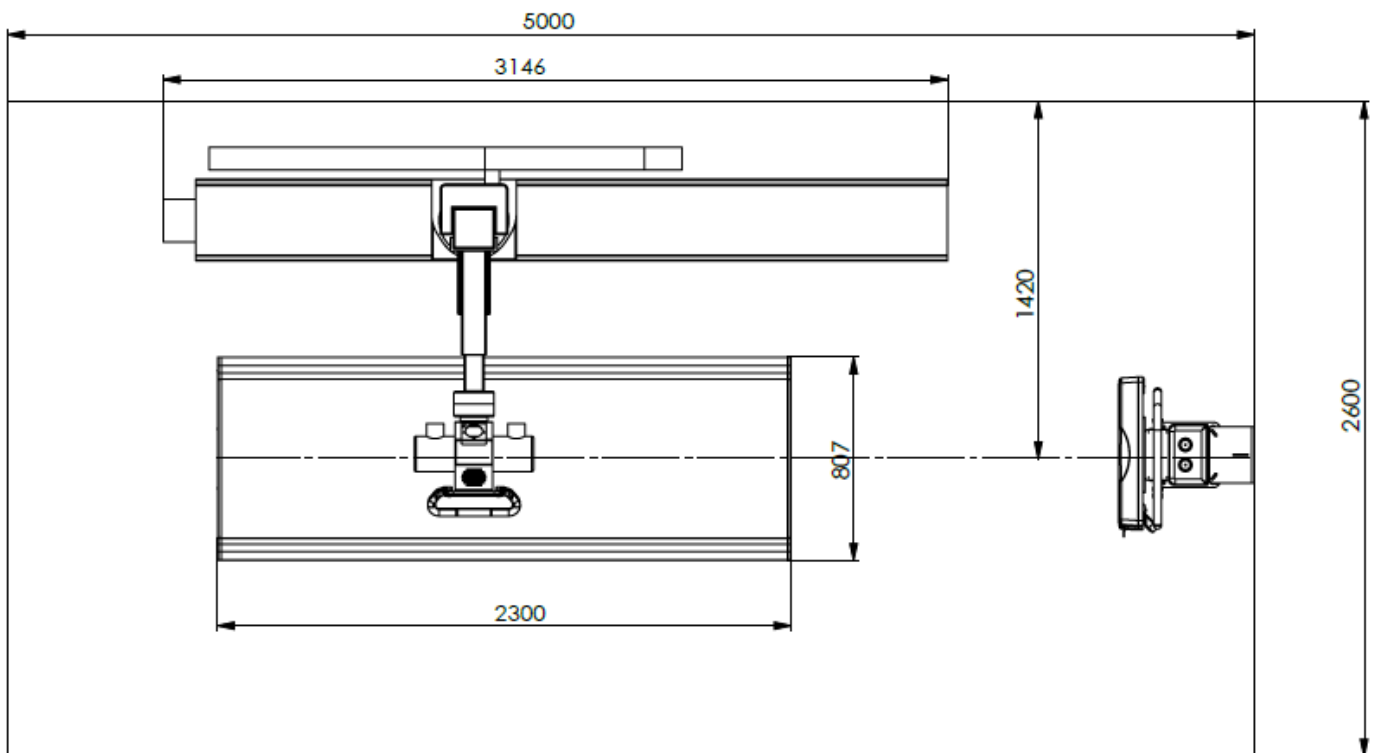
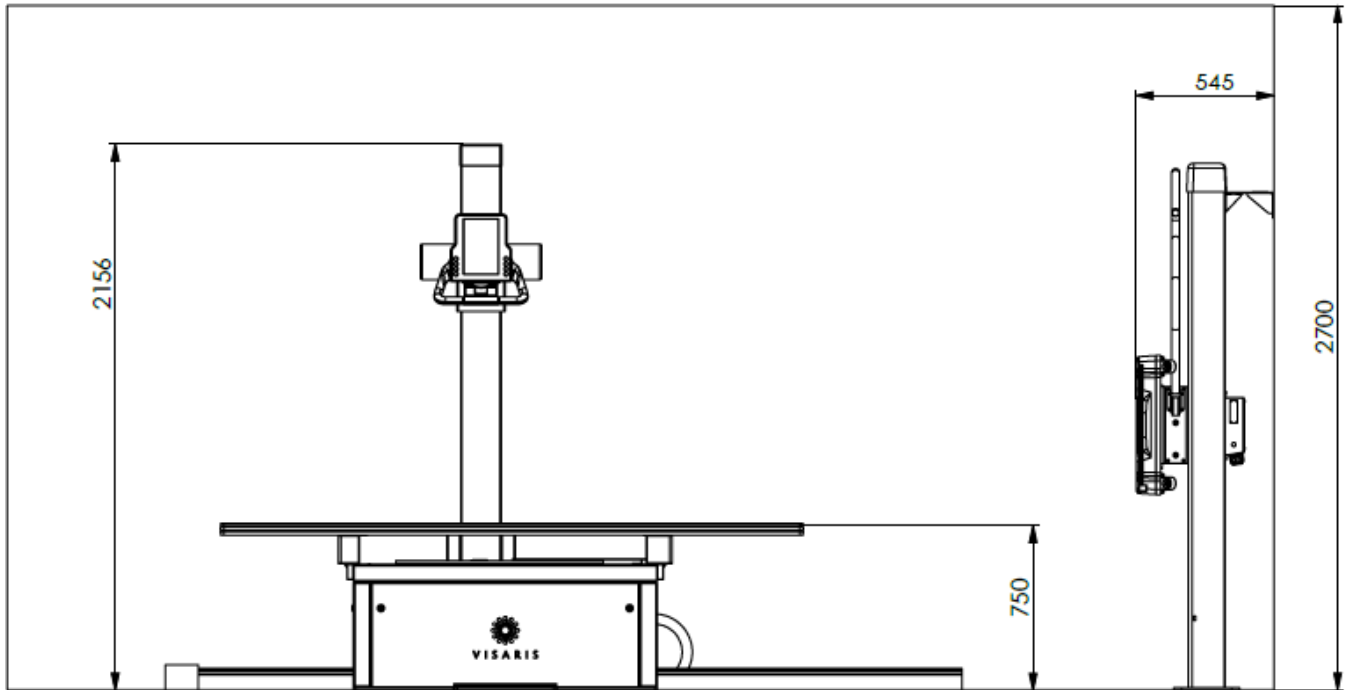

VISION V – CONFIGURATION

Vision V is a floor mounted general radiography system with manual (optionally motorised) positioning, vertical (optionally tilting) bucky stand and floating patient table (optionally elevating).

VISION V POSITIONING SYSTEM – FLOOR MOUNTED TUBE STAND		
Longitudinal travel	2540 mm (floor rails 3016 mm)	
Rotation around tube column	+/- 180°	
Focus-floor distance	400 to 1930 mm, stroke 1530mm	
Tube rotation	+/- 135° (may have higher values, but it is not recommended)	
Lateral tube movement	+/- 125mm	
Counter-balanced tube elevation	✓	
Safety system against breaking of rope	✓	
Focus-detector distance on table	up to 1170 mm on standard 760 mm table height	
Tube Stand has safety limits on the rails	✓	
Outer system dimensions (length, width, height)	3024x1485x2156	
Minimum Ceiling Height	2500mm	
Minimum Room Size	3m x 4m	
10.1" touchscreen system console on tube	Information display and controls: generator parameters, stand positioning, SID, tube angle, interlock, filtering, X-ray image preview	<input type="checkbox"/>
Buttonless all-release handle		



PATIENT TABLE

FEA 6-WAY table



Elevating radiography table with 4-way floating table top	✓	
Patient table top/ Table top transparency	Plastic Laminate/ <1 mm Al equivalent	
Table top dimensions	2.300 x 806 mm standard	<input type="checkbox"/>
	2.400 x 806 mm optional	<input type="checkbox"/>
Longitudinal range	±455 mm (for 2.300 mm tabletop) ±505 mm (for 2.400 mm tabletop)	
Transverse range	±130 mm	
Elevation range	Min 495 – Max 832 mm; Stroke 337 mm	
Elevation from minimum to maximum height:	<10 seconds	
Table top – detector distance	7 cm	
Max. patient weight	300 kg	
Horizontally adjustable bucky carriage range	540 mm ± 2 mm	
Electromagnetic brake with footswitch control for fixing the table top	✓	
Footswitches for control of table motions	✓	
Fully enclosed table base	✓	
Integrated detector bucky housing	✓	
Emergency stop button	✓	
Non-protruding edge rails for attachments	✓	

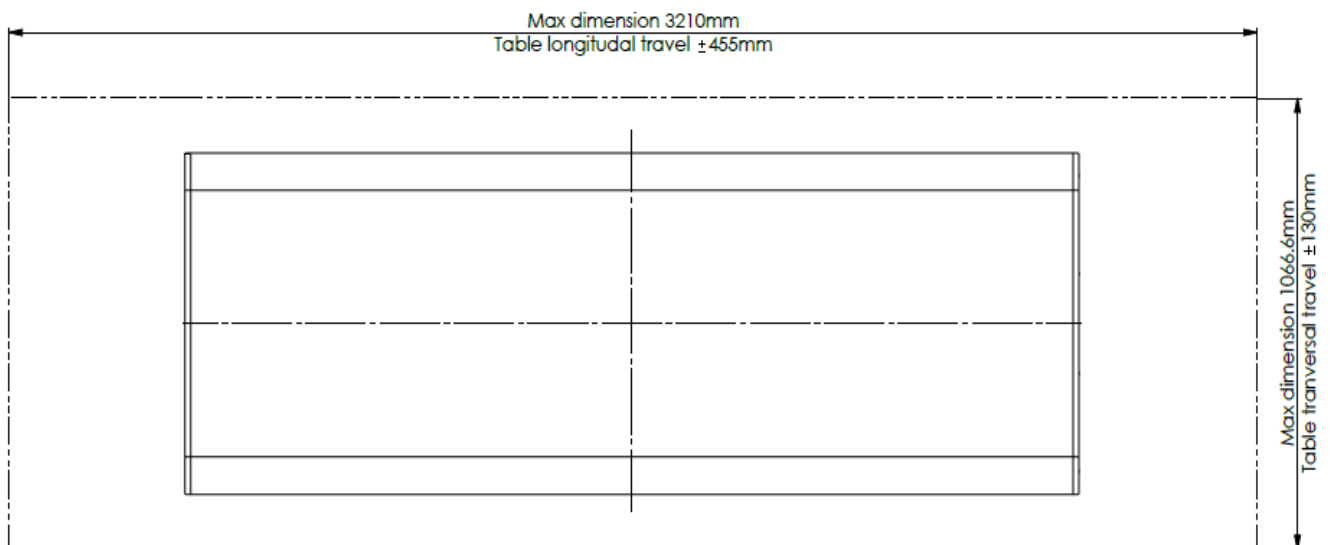
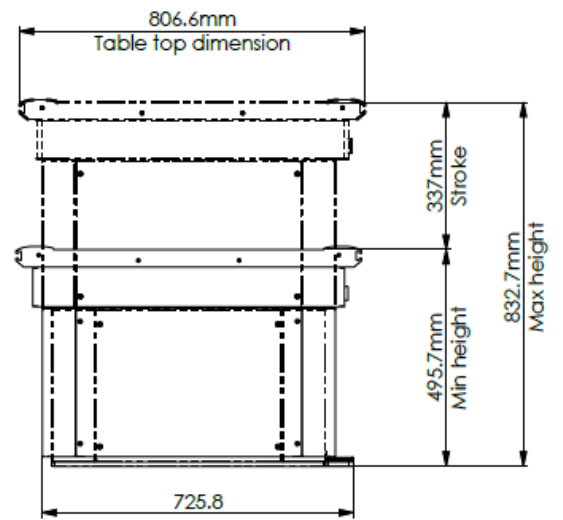
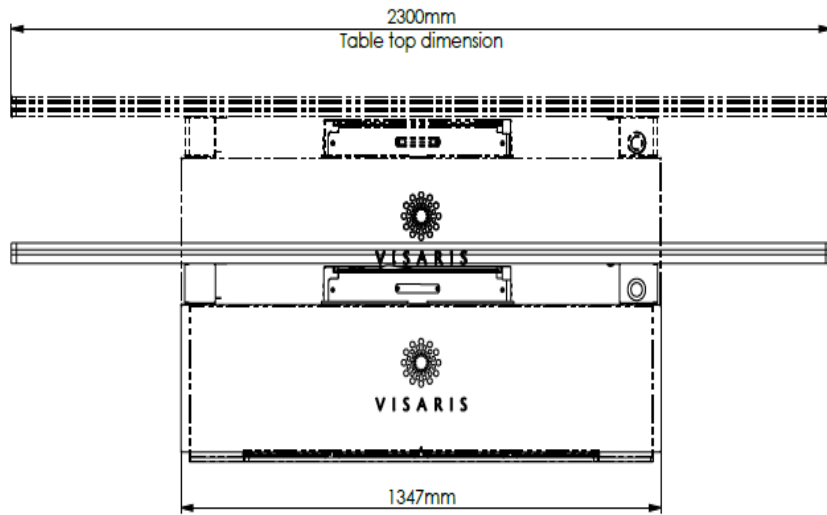

TT open elevating patient table – 6-Way Table

High-performance elevating radiography table with 4-way floating table top	✓	
Patient table top	carbon fiber	
Table top transparency	<0.65 mm	
Table Dimensions	2.400 x 887 x 465 mm	
Table-top dimensions	2.400 x 887 mm	
Longitudinal range	±600 mm	
Transverse range	±150 mm	
Elevation range		
- 6 hole fixation	up to 400mm, 465 – 865 mm	
- 4 hole fixation	up to 350mm, 515 – 865 mm	
Horizontally adjustable, motorised bucky carriage range	680 mm	
Max. patient weight	300 kg	
Table top immobilisation	EM permanent brakes with foot switch controls	
Wireless, movable control foot pedals with easy lift foot hook	✓	
Integrated detector bucky housing	✓	
Emergency stop button	✓	
Non-protruding edge rails for attachments	✓	

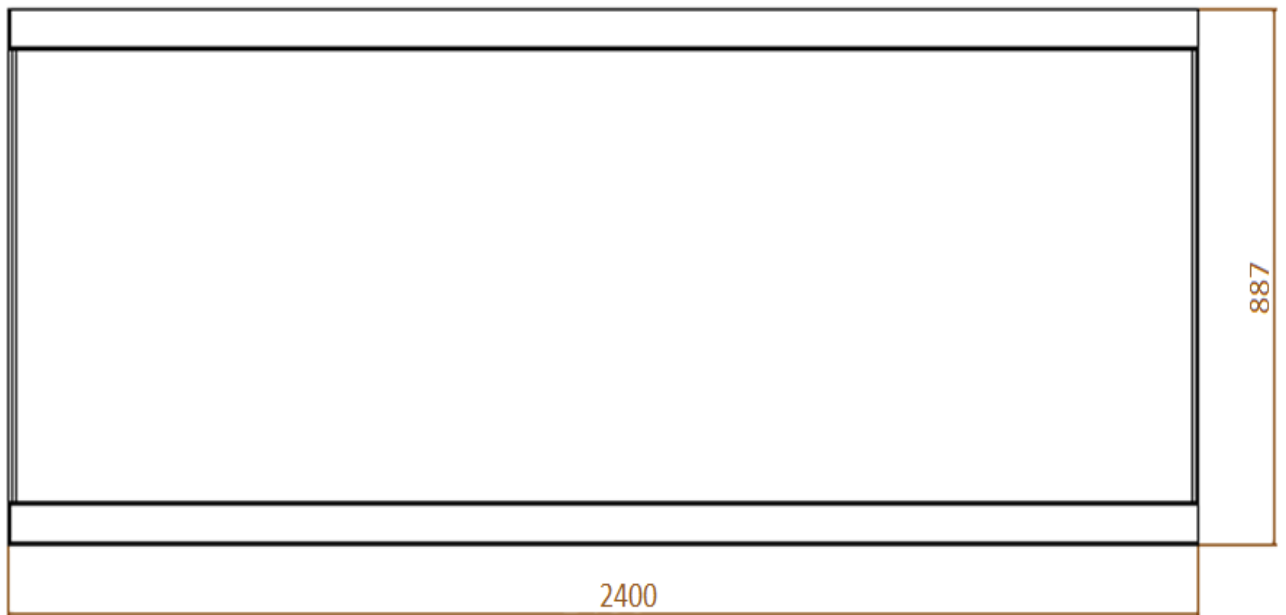
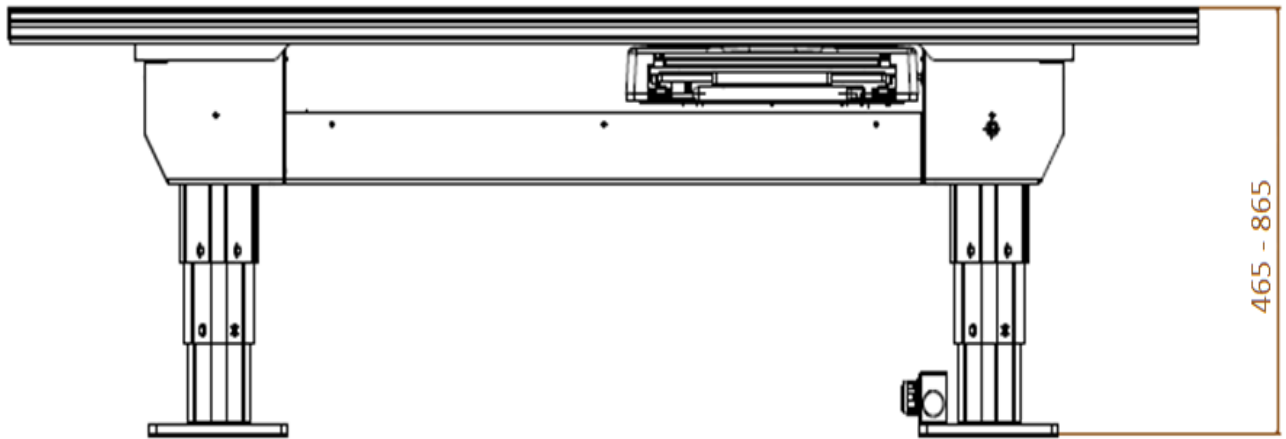

FEA 4-WAY table

Radiography table with 4-way floating table top	✓	
Patient table top	plastic laminate	
Table top transparency	<1 mm Al equivalent	
Table top dimensions	2.300 x 806 mm standard	<input type="checkbox"/>
	2.400 x 806 mm optional	<input type="checkbox"/>
Table height	750 mm standard	<input type="checkbox"/>
	650 mm optional	<input type="checkbox"/>
Longitudinal range	±455 mm (for 2.300 mm tabletop) ±505 mm (for 2.400 mm tabletop)	
Transverse range	±130 mm	
Table top – detector distance	7 cm	
Horizontally adjustable bucky carriage range	604 mm ± 2mm	
Electromagnetic brake with footswitch control for fixing the table top	✓	
Integrated detector bucky housing	✓	
Non-protruding edge rails for attachments	✓	

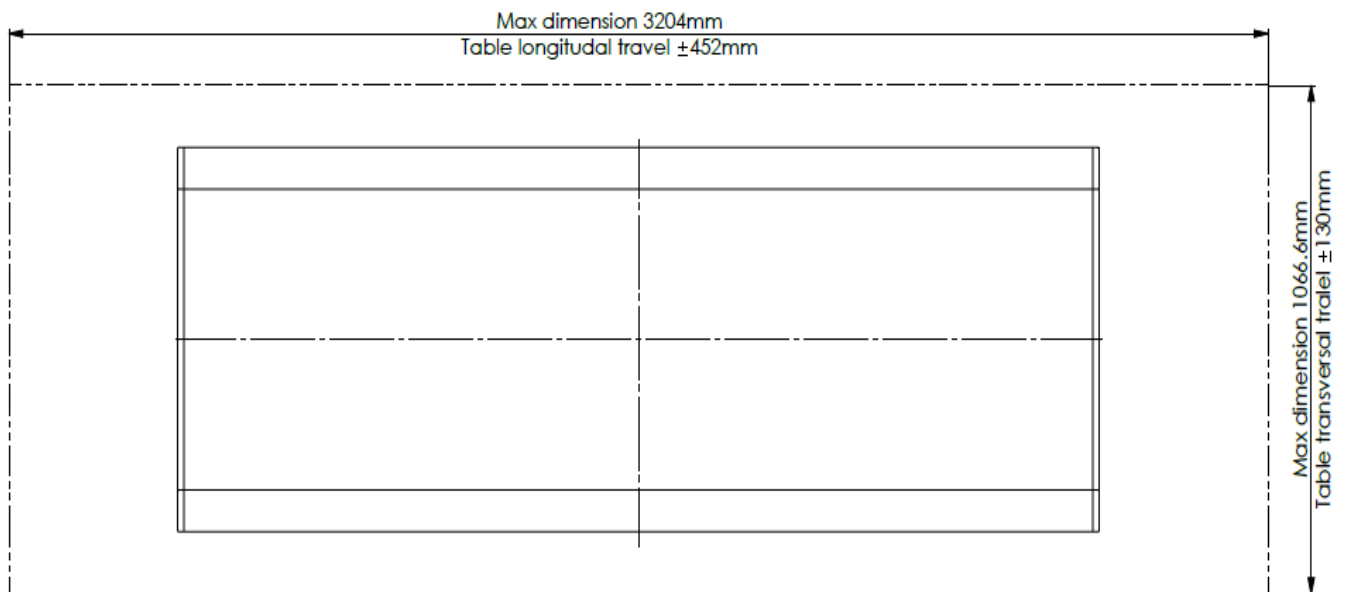
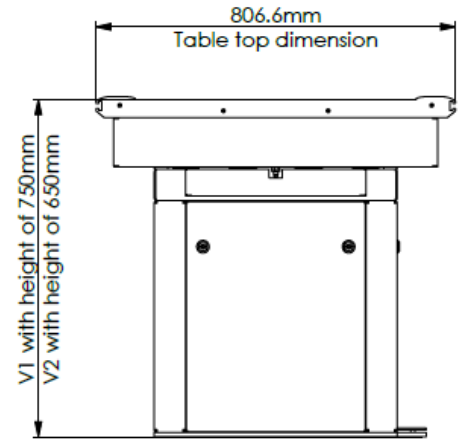
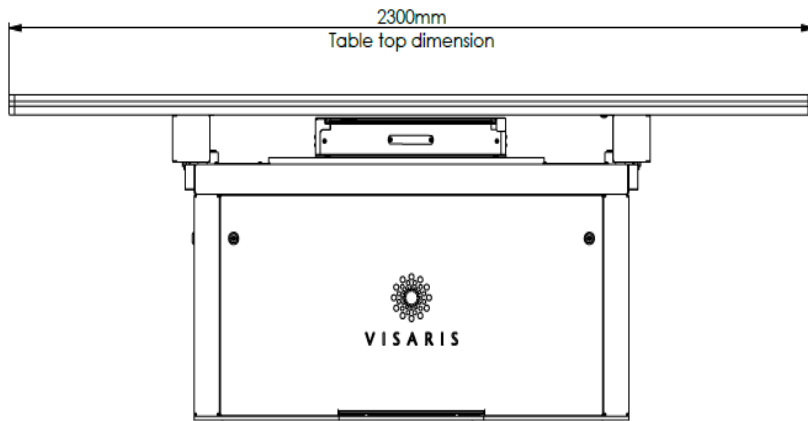

Radiography table accessories

Table bucky motorisation		<input type="checkbox"/>
Patient handles	✓	<input type="checkbox"/>
Patient compression belt	✓	<input type="checkbox"/>
Lateral detector holder, for cassette sized portable detectors	✓	<input type="checkbox"/>
Table foot controls	✓	<input type="checkbox"/>

PATIENT TABLE

Mobile patient table

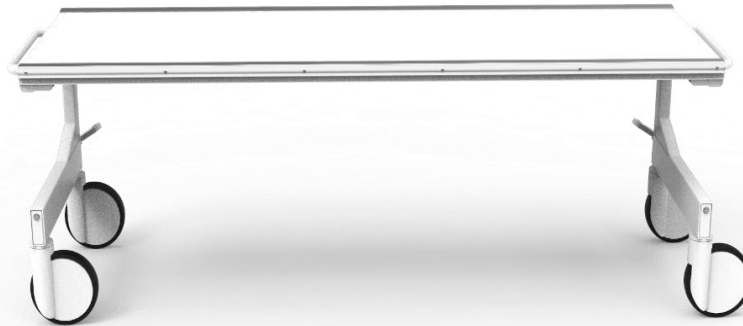

Patient table top	plastic laminate, 6mm	
Table top transparency	<1 mm Al equivalent	
Table height	705 mm	
Table top dimensions	2006 x 640 mm (1956 x 546 mm transparent)	
Max. patient weight	250 kg	
Table weight	52.5 kg	
Different wheel positions for easier movement control	✓	
Foot brakes on all wheels for easy table immobilisation	✓	
Handles on each end for easy table manipulation	✓	
Aluminium side rails for accessory mounting	✓	
Easy assembly from flat-pack packaging	✓	
Packaging dimensions	approx. 2200 x 900 x 330 mm	

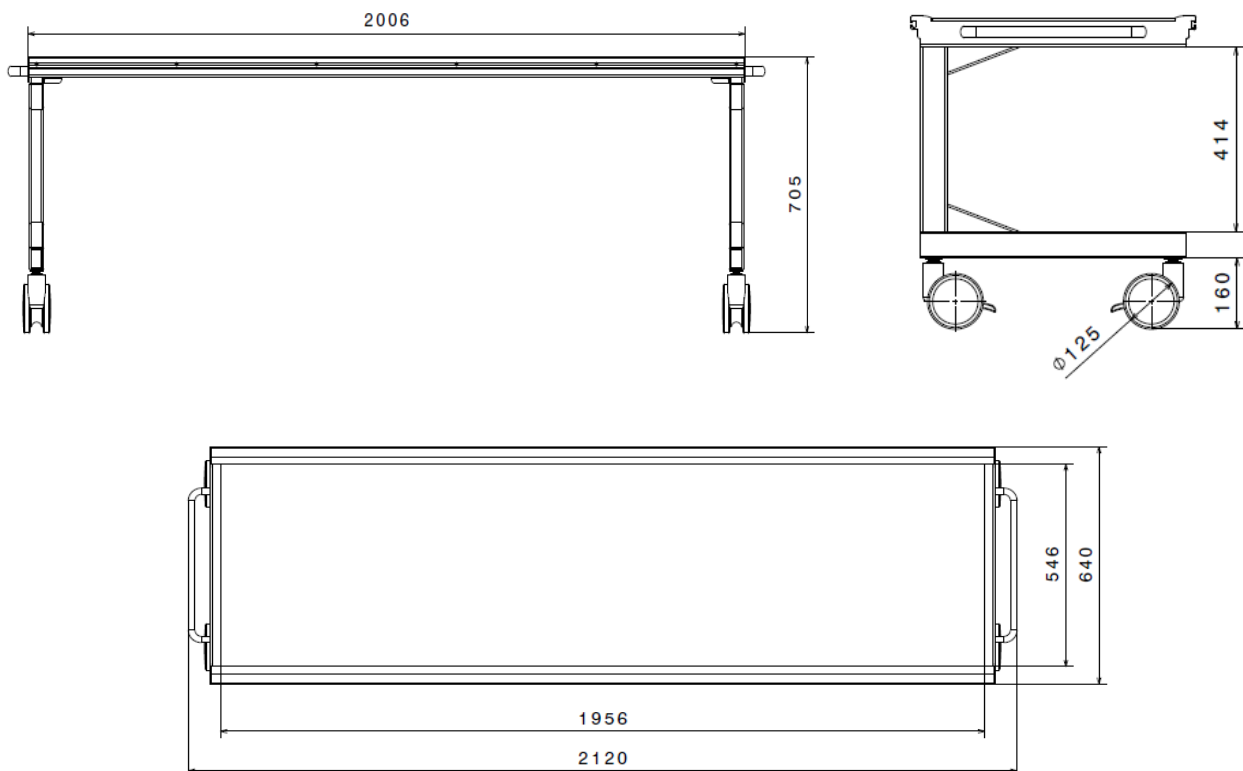

WALL STAND

Vertical wall stand

Vertical wall bucky stand with fully integrated detector bucky housing	✓	
Butonless manual elevation handle	✓	
Counter balanced for smooth vertical travel with easy handling	✓	
Electromagnetic brake secures vertical position	✓	
Vertical travel	1520 mm	
Designed for easy installation	✓	
Minimum height from floor to centre of detector	280 mm	
Maximum height from floor to centre of detector	1800 mm	
Chest PA handgrips	✓	

Vertical wall stand options

Orientation	Left	<input type="checkbox"/>
	Right	<input type="checkbox"/>
Wall stand motorised elevation Direction stand elevation control buttons Vertical tube tracking	✓	<input type="checkbox"/>
Wall stand tilting arm Manual positioning with 90° detents Electromagnetic brake with brake release command	+90°/-20°	<input type="checkbox"/>
Wall stand tilting arm motorisation Stand elevation control buttons Directional tilt control buttons	✓	<input type="checkbox"/>
Chest LAT handgrips	✓	<input type="checkbox"/>
Motorised collimation controls	✓	<input type="checkbox"/>
Additional movable pedal controls (2 way)	✓	<input type="checkbox"/>



VISION POWER PACK		
EMD EPS RAD		
Generator fully controlled by microprocessor	✓	
Power supply	400 VAC	
Number of phases	3 phase	
Frequency	Up to 240 kHz	
Exposure voltage range in 1 kV steps	40 – 150 kV	
High speed starter	✓	
Regulation range mAs	0.1 – 1000 mAs	
Time of exposure	1 – 10.000 ms	
Dual AEC operation (in table and wall stand buckies)	✓	
EMD EPS RAD 50		<input type="checkbox"/>
Generator power	50 kW	
Regulation range mA	10 – 630 mA	
EMD EPS RAD 65		<input type="checkbox"/>
Generator power	65 kW	
Regulation range mA	10 – 800 mA	
EMD EPS RAD 80		<input type="checkbox"/>
Generator power	80 kW	
Regulation range mA	10 – 1.000 mA	
CPI CMP 200		
Generator fully controlled by microprocessor	✓	
Power supply	208-230 VAC	
Number of phases	Single phase	
Frequency	Up to 400 kHz	
Exposure voltage range in 1 kV steps	40 – 125 kV	
Low speed starter	✓	
Regulation range mAs	0.1 – 500 mAs	
Time of exposure	1 – 6300 ms	
Dual AEC operation (in table and wall stand buckies)	✓	
CPI CMP 200 32 kW		<input type="checkbox"/>
Generator power	32 kW	
Regulation range mA	10 – 400 mA	
CPI CMP 200 40 KW		<input type="checkbox"/>
Generator power	40 kW	
Regulation range mA	10 – 500 mA	



RADIOGRAPHY TUBE		
Varex RAD-14/Leo		<input type="checkbox"/>
Anode heat capacity	300 kHu (210 kJ)	
Dual speed radiography tube	2.700 / 9.700 rpm	
Focal spots	0.6 / 1.2 mm	
Target diameter	74 mm	
Target angle	12°	
Maximum anode cooling rate	1.750 W/60 kHU/min	
kV Range	40 - 150 kV	
X-ray tube assembly heat content	1.250 kHU	
Power characteristics	32 / 77 kW (small / large focus)	
Varex RAD-60/Sapphire		<input type="checkbox"/>
Anode heat capacity	400 kHU	
Dual speed radiography tube	2.700 / 9.700 rpm	
Focal spots	0.6 / 1.2 mm	
Target diameter	100 mm	
Target angle	12°	
Maximum anode cooling rate	100 kHU/min	
kV Range	40 – 150 kV	
X-ray tube assembly heat content	1.500 kHU	
Power characteristics	40 / 100 kW (small / large focus)	
Varex RAD-92/ Sapphire		<input type="checkbox"/>
Anode heat capacity	600 kHU	
Dual speed radiography tube	2.700 / 9.700 rpm	
Focal spots	0.6 / 1.2 mm	
Target diameter	100 mm	
Target angle	12°	
Maximum anode cooling rate	140 kHU/min	
kV Range	40 – 150 kV	
X-ray tube assembly heat content	1.500 kHU	
Power characteristics	40 / 100 kW (small / large focus)	



COLLIMATOR		
Manual beam collimator Ralco R108		<input type="checkbox"/>
Inherent filtration, Al equivalent @ 75kV	2.0 mm	
Bucky Centering Light	LED	
Manual control knobs	✓	
Rating	maximum 150 kVp	
Light field illuminance	160 lx	
Timer automatically controls light time	✓	
Maximum Radiation Leakage	150 kVp - 4 mA	
Manual beam collimator Varex Optica 20		<input type="checkbox"/>
Inherent filtration, Al equivalent @ 75kV	2.0 mm	
Models with filter unit (optional) include a manual operated filter disk with 4 positions	No added filter 2 mm Al 1 mm Al + 0.2 mm Cu 1 mm Al + 0.1 mm Cu	
Bucky Centering Light	Power LED white, adjustable luminosity	
Manual control knobs	✓	
Rating	maximum 150 kVp	
Light field illuminance	160 - 220 lx, 1m from focal spot	
Timer automatically controls light time	✓	
Leakage radiation, IEC60601-1-3	≤ 0.5 mGy/hr	
Automatic beam collimator Varex Optica 30		<input type="checkbox"/>
Automatic shutter positioning from APR for selected technique in console worklist	✓	
Adjustable shutter opening for each technique in APR	✓	
Motorised additional filtration, set automatically from APR for selected technique:	1 mm Al + 0.1 mm Cu, 1 mm Al + 0.2 mm Cu, 2 mm Al + 0.3 mm Cu	
Inherent filtration, Al equivalent @ 75kV	1.2 mm	
Bucky Centering Light	long life POWER LED technology	
Light field illuminance	230 lx	
Leakage radiation, EN60601-1-3	≤ 0.5 mGy/hr	
Two tiers of shutters for fine field definition and low off-focal scatter radiation	✓	
kV Rating:	maximum 150 kVp	
Light timer	✓	
Digital readout of collimator field size and SID	With motorised system only	
Centering indication:	Laser crosshair and shadow crosshair	
Collimator options		
Collimator camera	✓	<input type="checkbox"/>

AUTOMATIC EXPOSURE CONTROL

Philips Amplimat

Single 5 field ionizing AEC	✓	<input type="checkbox"/>
Dual 5 field ionizing AEC	✓	<input type="checkbox"/>
Measuring fields	5 fields for symmetric operation	
Sensitivity	Typical at 70kV, 21mmAl: 0.6V/mGy	
kV range	40 – 150 kV	
Exposure time	1ms 6s	
Absorption	Eq. 0.8mm Al	
Detector housing integration	✓	

ANTI-SCATTER GRIDS

Soyee

Dense Anti-scatter grid Al, 85 l/cm, 10:1	f 110 cm	<input type="checkbox"/>
	f 150 cm	<input type="checkbox"/>
	f 180 cm	<input type="checkbox"/>
Dense Anti-scatter grid Carbon, 85 l/cm, 10:1	f 110 cm	<input type="checkbox"/>
	f 150 cm	<input type="checkbox"/>
	f 180 cm	<input type="checkbox"/>
Dense Anti-scatter grid Al, 85 l/cm, 8:1	f 33" – 44"	<input type="checkbox"/>
	f 40" – 72"	<input type="checkbox"/>

DOSE-AREA PRODUCT (DAP) METER

IBA Kermax

Digital readout into system console	✓	<input type="checkbox"/>
Equivalent filtration	0.2mm Al	
Light transparency	>75%	
Resolution	0.1 μ Gym=1 mGycm ² , 0.01	
Accuracy	25%	
kV range	40 – 150	

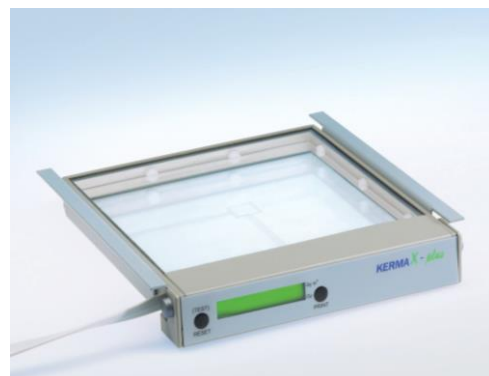

AVANSE DR ACQUISITION AND IMAGING SYSTEM

Imaging console

High performance PC	✓	
Multi core processor	Min i5	
RAM	8 GB	
Hard disk drive	1 TB	
DVD RW for export of images in DICOM format	✓	
Operating system	Windows 10	
WiFi Router, one for each WiFi detector	Enter number of routers	

Display

LCD monitor	23"	
Display resolution	1920x1080 (Full HD)	

Display options

Standard LCD monitor	✓	<input type="checkbox"/>
Non-medical touchscreen LCD monitor	✓	<input type="checkbox"/>
DICOM calibrated touchscreen LCD monitor	✓	<input type="checkbox"/>

Avanse software technical specifications

DICOM 3.0 MWL SCU import of modality worklists	✓	
DICOM 3.0 Store SCU export to PACS	✓	
DICOM 3.0 Print SCU print to DICOM printer	✓	
DICOM 3.0 Query, Retrieve, MPPS, Storage commitment		
Tools for image processing: zoom, contrast, brightness, rotate, flip, inverse, magnification	✓	
Algorithm for automatic harmonization	✓	
Advanced tools for image processing with enhanced visualization of bones and soft tissues	✓	
Integration with PACS and RIS enabled	✓	
Image printing on paper or film	✓	
Image archival and export in DICOM format	✓	
Image publishing on CD/DVD media in DICOM format with free DICOM viewer	✓	

Avanse software options

Detector Sharing		<input type="checkbox"/>
Calculated DAP		<input type="checkbox"/>



IMAGE STITCHING OPTION

Image stitching module

Single focus stitching in stand and table technique	
Stitching of up to 5 images	
Up to 150cm patient coverage	
Manual stitch position aid with automatic stand brake on next position	
Possibility to adjust x-ray technique for each individual image	
Full size stitching positioning trolley with 4 independent wheel locks	
Standing step for full leg studies and step folding for safe long spine studies (patient stands on floor)	
Dimensions 2000 x 860 x 950mm, Max patient weight 250kg	
Positioning detents and slider for accurate ruler positioning	
Radio-opaque ruler with positioning detents on stitching trolley	
APR entries for whole legs and spine, configurable additional stitching programs	
Automated image registration and stitching on imaging console	
Possibility to stitch all or only some of the acquired images	
Manual stitching function of any two images with easy selection	

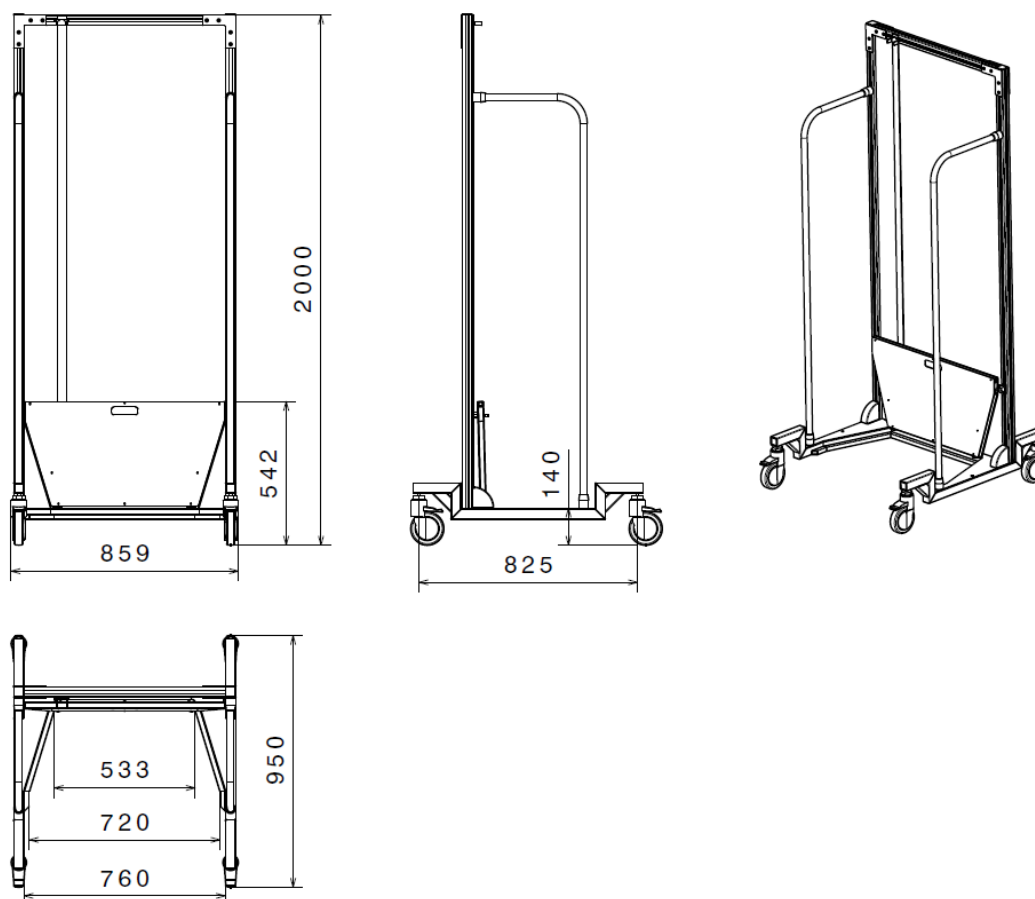

DIGITAL FLAT PANEL DETECTORS				
Receptor type/Scintillator	Amorphous silicium/CsI			
Fixed detector options				
Brand Model	Thales Pixium RAD 4343 C-E		Varex PaxScan 4343R v3	
Insert quantity				
Active area	423.3 x 425.4 mm		421 x 421 mm	
Active matrix	2860 x 2874		3032 x 3032	
Pixel size	148 µm		139 µm	
Limiting resolution	3.38 lp/mm		3.6 lp/mm	
DQE @ 0 lp/mm	65%		78%	
MTF @ 1 lp/mm	61%		56%	
AD conversion	16 bit		16 bit	
Detector dimensions	500 x 490 x 45.5 mm		469 x 469 x 37 mm	
Weight	11.7 kg		6.2 kg	
Wireless detector options				
Brand Model	Thales Pixium Portable 3543EZ-C	Thales Pixium Portable 2430EZ-C	Varex PaxScan 4336W v4 Config 2	Varex PaxScan 4343W
Insert quantity				
Active area	426 x 355 mm	284 x 231 mm	424 x 339 mm	421 x 421 mm
Active matrix	2846 x 2330	1920 x 1500	3032 x 2436	3072 x 3072
Pixel size	148 µm	148 µm	139 µm	139 µm
Limiting resolution	3.38 lp/mm	3.38 lp/mm	3.6 lp/mm	3.6 lp/mm
DQE @ 0 lp/mm	70%	66%	78%	76%
MTF @ 1 lp/mm	61%	61%	57%	57%
AD conversion	16 bit	16 bit	16 bit	16 bit
Ingress protection	IP43	IP43	IP54	IP68
Detector dimensions (mm)	459.5 x 383.5 x15.6	327.5 x 267.5 x15.6	459.5 x 383.5 x 15	460 x 460 x 15
Weight (with battery)	2.8 kg	1.6 kg	3.0 kg	3.3 kg
Battery autonomy	8 h	8 h	1600 images/8 h	1600 images/8 h
Point load	150 kg	100 kg	100 kg	200 kg
Distributed load	300 kg	150 kg	150 kg	300 kg
Gyroscopes				✓ (x, y, z)
Inductive charging				✓
Brand Model	iRay Mars 1417V version 3	iRay Mars 1717V version 3	iRay Mars 1417X	iRay Mars 1717X
Insert quantity				
Active area	420 x 345.6 mm	427x427 mm	430x350 mm	424.8x425.4 mm
Active matrix	2800 x 2304	3072x3072	3500x4300	4267x4267
Pixel size	150 µm	139 µm	100 µm	100 µm
Limiting resolution	3.3 lp/mm	3.6 lp/mm	5 lp/mm	5 lp/mm
DQE @ 0 lp/mm	61%	66%	68%	68%
MTF @ 1 lp/mm	75%	70%	65%	65%
AD conversion	16 bit	16 bit	16 bit	16 bit
Ingress protection	IPX1	IPX1	IP56	IP56
Detector dimensions (mm)	460 x 384 x 15	460 x 460 x 15.4	460 x 384 x 15	460 x 460 x 15
Weight (with battery)	3.3 kg	4.6 kg	3.0 kg	3.4 kg
Battery autonomy	5 h	5 h	8.5 h	8 h
Point load	100 kg	100 kg	150 kg	150 kg
Distributed load	150 kg	150 kg	300 kg	300 kg

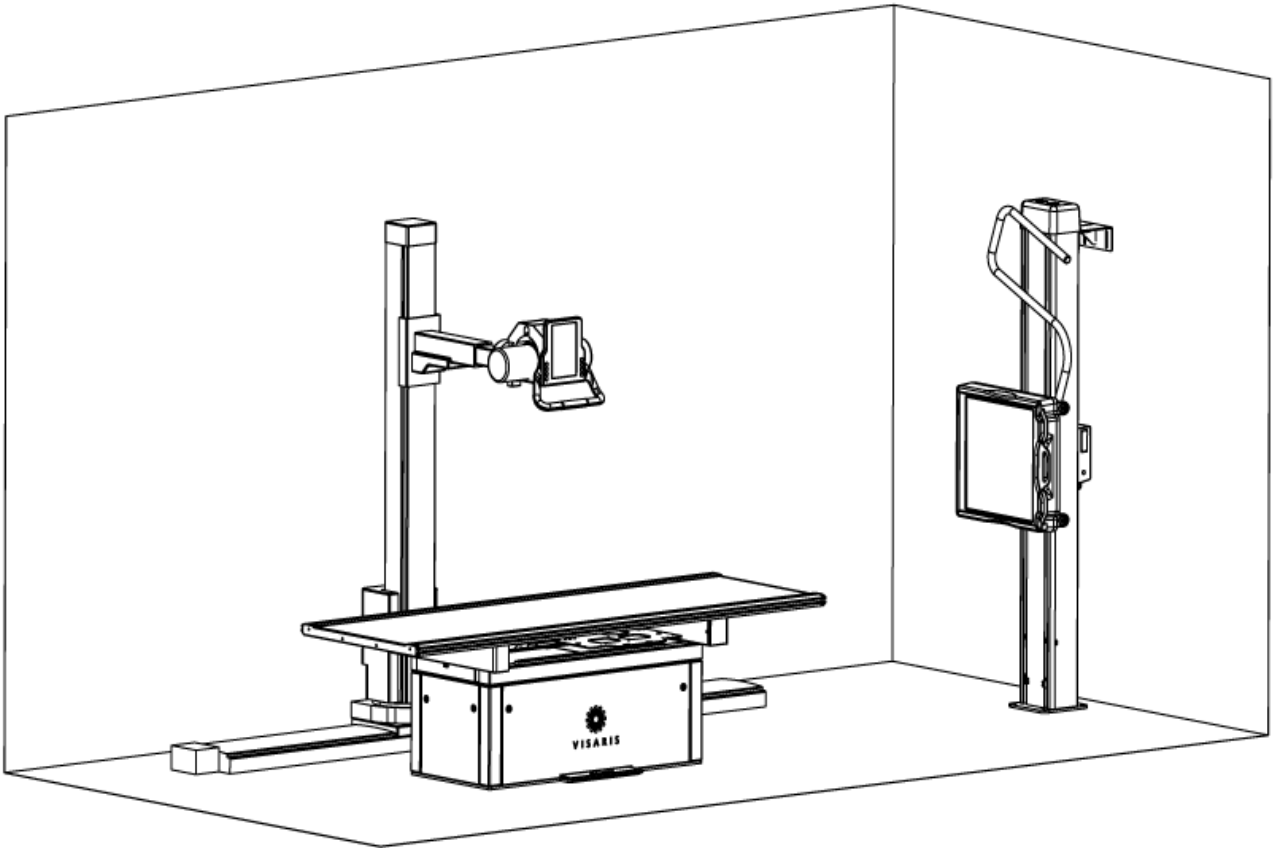



Sales Book VISION V



VISARIS D.O.O. BEOGRAD
Batajnicketi drum 10 deo 1B | 11080 Zemun | Srbija
T: +381 11 2017 650 | F: +381 11 2017 670 | M: +381 65 2017 650
E-mail: info@visaris.com



REPUBLICA



MOLDOVA

AGENȚIA NAȚIONALĂ DE REGLEMENTARE A ACTIVITĂȚILOR NUCLEARE ȘI RADIOLOGICE

MD-2068, mun. Chișinău, str. Alecu Russo, 1
tel/fax: (+373 22) 31 11 37, e-mail: agentia.nucleara@anranr.gov.md

AUTORIZAȚIA RADIOLOGICĂ

Seria A

Nr. 1141

Denumirea, forma juridică de
organizare, adresa juridică a
titularului

Întreprinderea cu Capital Străin
"EYECON MEDICAL"
Societatea cu Răspundere Limitată
MD-2069, mun. Chișinău, piata D. Cantemir, 1, of. 1427

Codul fiscal/Codul IDNO

1012600036108

Genul de activitate nucleară sau
radiologică pentru care se eliberează

Importul/exportul și furnizarea
surselor generatoare de radiații ionizante

Limitele de activități și condițiile

Importul/exportul și furnizare a instalațiilor roentgen de
tip: "Vision" cu prezența certificatului de conformitate,
eliberat de un organism notificat și publicat în Jurnalul
Oficial al Comunității Europene

Prenumele, numele persoanei
responsabile de radioprotecție

Ioan Răzvan Cârstocea

Numărul permisului de exercitare

-

Data emiterii

06.07.2022

Data expirării

06.07.2027

**Conducător,
inspector principal de stat adjunct
în domeniul activităților nucleare și radiologice**

Ionel BĂLAN

(semnătura)

