



42250 SELÇUKLU/KONYA

TECHNICAL DESCRIPTION

Figure on helical spring

The figurine on a helical spring with vertical swing, intended for children aged between 2-8 years, intended for one user, composed of a galvanized pressed metal foundation assembly; helical spring assembly, spring spiral of 18 mm and height of 400 - 450 mm; figurine made of HDPE panels with a thickness of 18 mm; 2 HDPE handles with metal inserts without toxic components according to the technical test report; HDPE leg supports with metal inserts without toxic components; HDPE seat; self-braking stainless steel screws and nuts assembly elements; covers and PE washers for the protection of screws and nuts.

Dimensions: Length: 75 cm, width: 25 cm, height: 80 cm.;

The safety surface will be 4-6 m².

The fixing of the equipment will be done with a galvanized pressed metal foundation assembly, in a B150 concrete foundation, at a depth of 50cm, width of 40cm and length of 75cm



42250 SELÇUKLU/KONYA



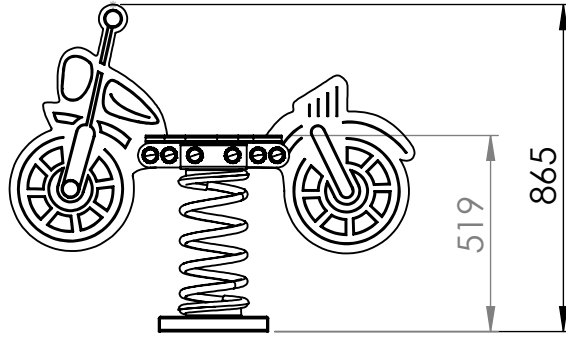

3071

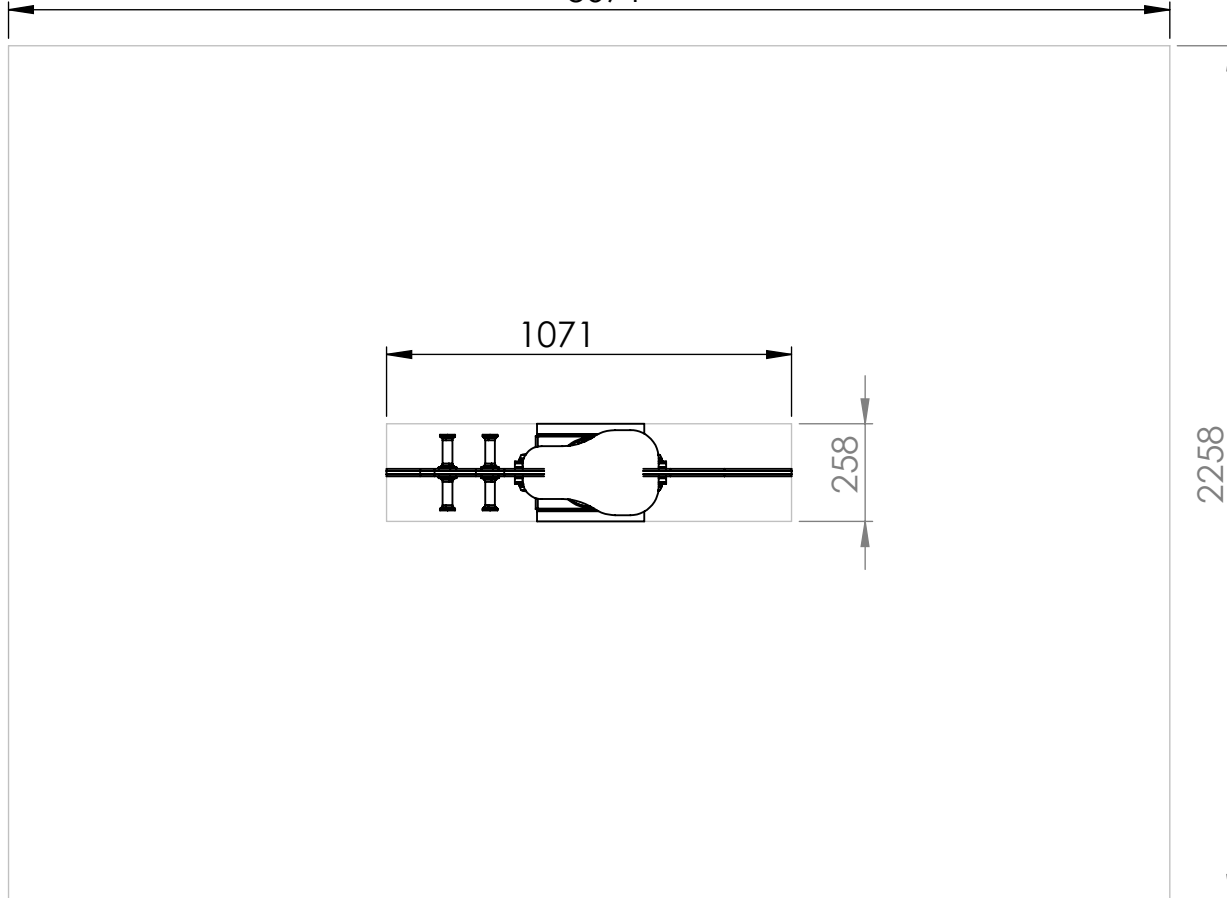

1071

258

2258