

INSTALLATION, OPERATION & MAINTENANCE MANUAL

"Y" Strainers



Ref. GENE BRE:
2458G – 2459 – 2459A – 2460 – 2460N – 2461 – 2461A

INSTRUCTIONS FOR INSTALLATION, OPERATION & MAINTENANCE MANUAL

1. Spare Parts	3
1.1 Parts List	3
2. Transport and Storage conditions	4
3. Installation Instructions	5
3.1 Preparation	5
3.2 Installation	5
3.3 Surrounding space	7
4. Maintenance Instructions	9
5. Cleaning Instructions	9
6. Torques	9
7. Safety Instructions	10

1) Spare Parts.

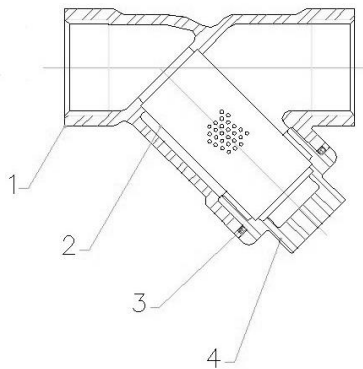

Ref.: 2460 – 2460N

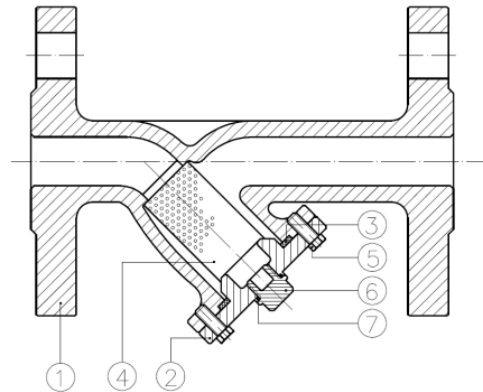

Ref.: 2458G – 2459 – 2459A – 2461 – 2461A

1.1) Parts List

2460 – 2460N

Nº	Name	Material	Surface Treatment	Spare Part Code
1	Body	Stainless Steel 1.4408	Shot blasting	-----
2*	Screen	Stainless Steel AISI 316	-----	2991
3*	Gasket	PTFE	-----	2991
4	Cover	Stainless Steel 1.4408	Shot blasting	-----

* Available spare parts

2461 – 2461A

Nº	Name	Material	Surface Treatment	Spare Part Code
1	Body	Stainless Steel 1.4408	Shot blasting	-----
2	Cover	Stainless Steel 1.4408	Shot blasting	-----
3*	Gasket	PTFE	-----	J2461
4*	Screen	Stainless Steel AISI 316	-----	2861 / 2861A
5	Bolt	Stainless Steel AISI 304	-----	-----
6	Plug G1/2" (from 1 1/4")	Stainless Steel AISI 316	-----	-----
7	Gasket	PTFE	-----	-----

* Available spare parts

2458G

Nº	Name	Material	Surface Treatment	Spare Part Code
1	Body	Cast Iron EN-GJS-400 (GGG40)	Epoxy coating	-----
2	Cover	Cast Iron EN-GJS-400 (GGG40)	Epoxy coating	-----
3*	Gasket	PTFE + Graphite	-----	J2458G
4*	Screen	Stainless Steel AISI 304	-----	T2458G
5	Bolt	Stainless Steel AISI 304	-----	-----
6	Plug	Stainless Steel AISI 304	-----	-----

* Available spare parts

2459

Nº	Denominación / Name	Material	Acabado Superficial / Surface Treatment	Cód. Recambio / Spare Part Code
1	Cuerpo / Body	Fundición / Ductile Iron EN-GJS-400	Pintura anticorrosiva / Heat resistant paint	-----
2	Tapa / Cover	Fundición / Ductile Iron EN-GJS-400	Pintura anticorrosiva / Heat resistant paint	-----
3*	Junta / Gasket	AISI 304 + Grafito / AISI 304 + Graphite	-----	J2459
4*	Tamiz / Mesh	Acero Inox / St. Steel AISI 304	-----	T2459
5	Tornillo / Bolt	Acero Inox / St. Steel AISI 304	-----	J2459
6	Tapón / Plug	Acero Inox / St. Steel AISI 304	-----	-----
7	Junta / Gasket	Cobre / Copper	-----	-----

* Available spare parts

2459A

Nº	Denominación / Name	Material	Acabado Superficial / Surface Treatment	Cód. Recambio / Spare Part Code
1	Cuerpo / Body	Fundición Nod. / Ductile Iron ASTM A536 Gr. 65-45-12	Pintura anticorrosiva / Heat resistant paint	-----
2	Tapa / Cover	Fundición Nod. / Ductile Iron ASTM A536 Gr. 65-45-12	Pintura anticorrosiva / Heat resistant paint	-----
3*	Junta / Gasket	AISI304 + Grafito / AISI304 + Graphite	-----	J2459A
4*	Tamiz / Mesh	Acero Inox / St. Steel AISI 304	-----	T2459A

5	Tornillo / Bolt	Acero Inox / St. Steel AISI 304	-----	-----
6	Tapón / Plug	Acero Inox / St. Steel AISI 304	-----	-----
7*	Junta / Gasket	Cobre / Copper	-----	J2459A

* Available spare parts

Genebre, S.A. offers a wide range of products designed and assembled to handle and drive fluids in industrial procedures.

The application of these products to the different industrial processes is at user's risk. Strainer will have an optimal behaviour when working conditions do not exceed pressure and temperature limits for which they have been designed. Please, refer to the product data sheet.

2. Transport and Storage conditions



Transport and storage of this type of products must be done in their original package

VISUAL INSPECTION

Check whether during transport, unloading and placement products have suffered any damage.



If you notice any kind of anomaly during reception of the goods, contact immediately with GENE BRE in order to determine the possible responsibilities on the issue.

In case that the strainer is not installed immediately, keep it with protective packaging to prevent strokes or accumulation of dirt (it should not be removed until the strainer is going to be installed). As far as possible, the strainer should be stored in a dry and clean area

IMPORTANT NOTE:

Before installing and/or manipulating these elements READ CAREFULLY the enclosed instructions for use and OBSERVE all contained information. If any of the contents is not clear enough, please contact GENE BRE, S.A.



User is responsible for the safe use of these products, as established in present instructions for use and in the specific technical documentation of the supplied device.

3) Installation Instructions

3.1) Preparation

Remove any remaining packing materials from the strainer.

There may be serious problems with any accessory installed in a dirty pipe.

Make sure the pipe is free of dirt, welding particles, etc. before installations because the accessory could get irreparable damage when starting-up → prepare a *clean working area*. Provide enough space for future maintenance.

In case of vibrations in the pipe it is strongly recommended to mount anti-vibration elements to absorb them. Otherwise, the life of the product could be drastically reduced.

3.2) Installation

2460 – 2460N

Make sure the strainer's pipe and thread end are clean and are compatible one with another (type of thread end) Apply an appropriate sealing in the pipes' thread ends and thread the strainer being careful not to excessively tighten the conical threaded ends (2460N).

To tighten the strainer it is recommended to use a spanner or monkey wrench only on the hexagonal area of the strainer edges; the force applied being less than 30 Nm.

2458G – 2459 – 2459A – 2461 – 2461A

Use flat gaskets between strainer and pipe flanges to ensure sealing.

The strainers are designed for mounting between flanges EN 1092 PN16 (Art. 2458, 2459 & 2461) and flanges ANSI B 16.5 S150 (Art. 2459A & 2461A).

Check the parallelism of the flanges. Keep enough space between them so that the strainer can be inserted or removed easily.

Tighten the screws of the flanges to hold the strainer firmly. Apply the alternate clamping method to ensure proper installation. To obtain more information, please consult the maximum torque values for the flanges in the table in section 6 of this manual.

IMPORTANT:

Pay particular attention to the flow direction of the valve marked by an arrow in the body.

Correct Installation Position

2458G – 2459 – 2459A – 2460 – 2460N – 2461 – 2461A

Horizontal installation is recommended, the *Mesh* never upwards. In case of vertical installation, the *Mesh* should point downwards.

See below:



HORIZONTAL



VERTICAL DOWNWARDS



For steam systems, condensate accumulation in the strainer must be avoided. Strainer to be set in horizontal pipe with the *Mesh* in horizontal position and pipe system with a slight negative slope.

3.3) Surrounding space

With the purpose of leaving enough space for future maintenance tasks, it is recommended to keep a space near the Screen area free of any object, floor, wall, etc. as indicated in the following table:

SIZE ↓	Dimension A2 (mm)			
	Art. 2458G/2459/2459A	Art. 2460(N)	Art. 2461	Art. 2461A
DN8 (1/4")	***	67	***	***
DN10 (3/8")	***	67	***	***
DN15 (1/2")	***	69	122	***
DN20 (3/4")	***	86	138	***
DN25 (1")	***	108	158	***
DN32 (1 1/4")	***	115	177	***
DN40 (1 1/2")	200	134	201	***
DN50 (2")	225	155	240	244
DN65 (2 1/2")	254	***	311	307
DN80 (3")	269	***	360	314
DN100 (4")	337	***	378	376
DN125 (5")	410	***	451	***
DN150 (6")	452	***	482	485
DN200 (8")	559	***	623	638
DN250 (10")	665	***	***	***
DN300 (12")	775	***	***	***

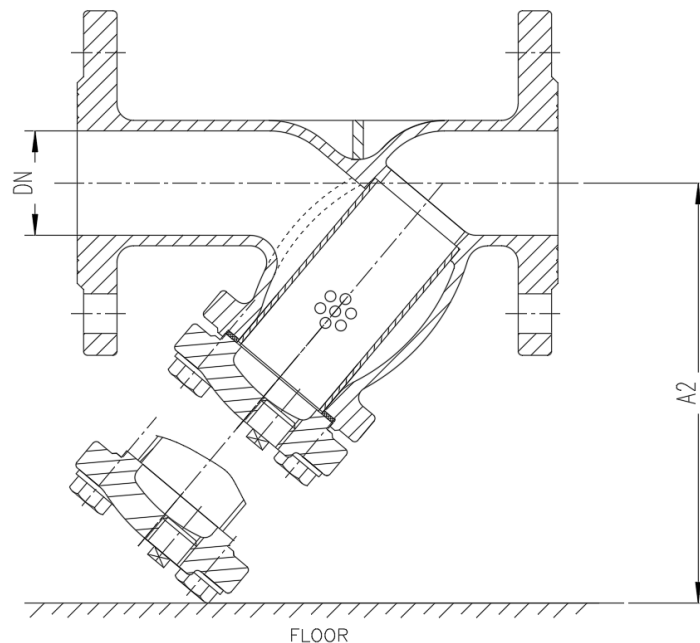

4) Maintenance instructions



It is responsibility of the user to establish a plan of inspection and maintenance of these apparatuses with the purpose of guaranteeing its safe use.

The inspections must be made only by qualified personnel, in accordance with the type of equipment and installation required.

Frequency, location and process of maintenance will be determined by the user by taking into account usage of the product.



Before disassembling the pipe's strainer to repair or replace it, make sure that line has been closed and depressurized because a bad operational procedure could cause a serious accident to you or to the installation system

Prepare a clean working area and appropriate tooling for mechanical tasks.

Strainer's *mesh* must be extracted and cleaned when clogging becomes apparent.

5) Cleaning Instructions

2460 – 2460N

Disassembly

Loosen and remove the *plug* (part.4), remove the *mesh* (part.2) from inside of *body* (part.1), remove the *gasket* (part.3).

Clean the *mesh* with compressed air or another method.

If they were damaged or in case of doubt, they will need to be replaced the *mesh* and *gasket*.

Clean inside the body.

Assembly

Insert the *mesh* (part.2) inside of the *body* (part.1), insert the *gasket* (part.3) on the *plug* (part.4) and tighten.

2458G – 2459 – 2459A – 2461 – 2461A

Disassembly

Loosen and remove the *bolts* (part.5), remove the *cover* (part.2), remove the *mesh* (part.4) from inside of *body* (part.1), remove the *gasket* (part.3).

Clean the *mesh* with compressed air or another method.

If they were damaged or in case of doubt, they will need to be replaced the *mesh* and *gasket*.

Clean inside the *body*.

Assembly

Insert the *mesh* (part.4) inside of the *body* (part.1), insert the *gasket* (part.3) on the *cover* (part.2) and tighten. Apply the alternate clamping method to ensure proper installation.

6) Torques

Maximum recommended torque to tighten the flanges' screws

Size	Maximum torque value (N.m.)
1 1/4" ~ 4"	50
5" ~ 6"	60
8" ~ 14"	80
16" ~ 20"	100

7) Safety Instructions

7.1) The fluids pass through a valve or accessory can be corrosive, toxic, flammable or pollutant. They can also be found at very high or low temperature. When handling valves or accessory shall be taken necessary security measures and it is advisable to use personal protective equipment:

- 1) Wear eye protection.
- 2) Wear gloves and appropriate work clothes.
- 3) Wear safety shoes.
- 4) Wear a helmet.
- 5) Note the availability of running water.
- 6) For flammable fluids, make sure you have a fire extinguisher.

7.2) Before removing a valve or accessory from a pipe, always check that the line is completely cold, drained and depressurized.

7.3) Any valve or accessory that was used in toxic services must have a cleaning certificate before handling.

7.4) Any type of repair or maintenance should be performed in ventilated places.