



MMM Group

**CO2CELL** 190 Comfort

**CO2CELL** 190S Comfort  
(with sterilization 200 °C)

CO<sub>2</sub> Incubator

Instructions for use

CE

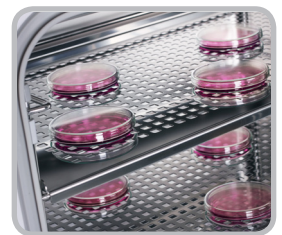



## CONTENTS:

24. 1. 2013

<b>1</b>	<b>SAFETY .....</b>	<b>3</b>
1.1	LEGAL CONSIDERATIONS .....	3
1.2	INTENDED USE.....	3
1.3	SYMBOLS USED IN THIS MANUAL .....	3
1.4	GENERAL SAFETY INSTRUCTIONS.....	3
<b>2</b>	<b>DESCRIPTION.....</b>	<b>3</b>
2.1	CONSTRUCTION .....	4
2.2	DOORS .....	4
2.3	CONTROL SYSTEM.....	4
2.4	CO <sub>2</sub> SENSOR.....	4
2.5	DIAGRAMS .....	4
2.5.1	OUTER VIEW .....	4
2.5.2	INNER VIEW .....	4
2.5.3	REAR CONNECTIONS .....	4
<b>3</b>	<b>DELIVERY, TRANSPORTATION AND STORAGE .....</b>	<b>5</b>
3.1	UNPACKING.....	5
3.2	LIFTING AND MOVING .....	5
3.3	STORAGE .....	5
<b>4</b>	<b>INSTALLATION .....</b>	<b>5</b>
4.1	LOCATION AND AMBIENT CONDITIONS .....	5
4.2	SHELVES AND USABLE SPACE .....	6
4.3	WATER TRAY.....	6
4.4	GAS CONNECTION .....	6
4.5	ELECTRICAL CONNECTION .....	6
<b>5</b>	<b>GETTING STARTED .....</b>	<b>7</b>
5.1	START UP .....	7
5.2	SETTING TIME AND DATE.....	7
5.3	FACTORY PRESETS.....	7
5.4	CHANGING TEMPERATURE SET POINTS AND HIGH / LOW ALARMS .....	7
5.5	CHANGING CO <sub>2</sub> SET POINT AND ALARM THRESHOLDS .....	8
5.6	ALARM STATUS SCREEN.....	8
<b>6</b>	<b>OTHER FEATURES .....</b>	<b>9</b>
6.1	GRAPHICAL DISPLAY .....	9
6.2	UTILITY MENU.....	9
6.3	DOOR ALARM MENU.....	10
6.4	INCUBATOR INFORMATION .....	10
6.5	HISTORICAL EVENT LOG.....	10
6.6	USER SECURITY.....	10
6.6.1	ENTERING A USER NAME AND PASSWORD.....	10
6.6.2	ENABLING SECURITY .....	10
6.6.3	LOGGING OUT .....	11
6.6.4	DISABLING SECURITY .....	11
<b>7</b>	<b>SD CARD DATA LOGGING .....</b>	<b>11</b>
7.1	START LOGGING.....	11
7.2	CHANGING FILENAME .....	12

7.3	REMOVING THE SD CARD .....	12
<b>8</b>	<b>HIGH TEMPERATURE STERILISATION.....</b>	<b>13</b>
8.1	PREPARATION.....	13
8.2	STARTING THE CYCLE .....	13
8.3	STERILISE CYCLE .....	13
8.4	COOLING PHASE .....	14
8.5	ABORTING THE STERILISE CYCLE .....	14
<b>9</b>	<b>ERROR MESSAGE SCREENS.....</b>	<b>14</b>
<b>10</b>	<b>OPTIONS .....</b>	<b>15</b>
10.1	VOLT FREE ALARM RELAY (BMS) .....	15
10.2	4-20 MA RETRANSMISSION (RETX) .....	15
10.3	RS 232 SERIAL COMMUNICATION (232).....	15
10.4	ETHERNET COMMUNICATION (ETH) .....	15
10.5	MULTI-DOOR (8ID).. .....	15
<b>11</b>	<b>ACCESSORIES.....</b>	<b>15</b>
<b>12</b>	<b>CLEANING .....</b>	<b>16</b>
12.1	OUTER SURFACES .....	16
12.2	INNER SURFACES .....	16
12.3	OXIDATION AT HIGH TEMPERATURE (COMFORT 190S ONLY).....	16
<b>13</b>	<b>SERVICE .....</b>	<b>16</b>
13.1	WARRANTY.....	16
13.2	PREVENTATIVE MAINTENANCE .....	16
13.3	RETURNING A UNIT .....	16
<b>14</b>	<b>DISPOSAL.....</b>	<b>17</b>
<b>15</b>	<b>TECHNICAL INFORMATION.....</b>	<b>17</b>
15.1	TECHNICAL DATA.....	17
15.2	DIMENSIONAL DRAWINGS .....	17

# 1 SAFETY

## 1.1 LEGAL CONSIDERATIONS



It is important that you read this manual completely and observe all instructions. Failure to follow these instructions may result in personal injury, equipment damage and incorrect performance of the incubator.

This manual contains information for installing, operation and maintenance of the incubator. It cannot cover all possible uses and applications. Please contact your dealer or MMM directly if you have a special application or the manual does not describe your problem in enough detail.

The contents of this manual and the incubator are subject to change without notice.

## 1.2 INTENDED USE

The CO<sub>2</sub>CELL Comfort 190 incubators are intended for mammalian cell cultivation under typical conditions of 37.0 °C. The pH of the cell media can be controlled by altering the CO<sub>2</sub> concentration within the incubator.

Other applications are not approved by MMM. Please contact your dealer or MMM directly, for advice if you intend to use this incubator for other applications.

## 1.3 SYMBOLS USED IN THIS MANUAL

The following symbols are used throughout this manual:

Risk of injury	Electrical hazard	Hot surface	Lifting hazard
Stability hazard	Compressed gas hazard	Asphyxiation hazard	Mandatory regulation
Read operating manual	Lift with several persons	Disconnect from electrical supply	Important information for correct operation

## 1.4 GENERAL SAFETY INSTRUCTIONS

This incubator is intended for use by suitably qualified laboratory personnel who are familiar with all precautions and standard safety practices for working in a laboratory environment.

These safety instructions are intended to be used alongside any local safety guidelines, rules and regulations. If in doubt please consult the Health and Safety Officer of your organisation.

Only skilled electricians or engineers authorised by MMM can perform repairs or maintenance on this incubator. Only original spare parts from MMM can be used. There are no user serviceable parts within the incubator.

MMM takes no responsibility for 3rd party accessories or equipment used with this incubator.

 <b>DANGER</b>	<b>Electrical hazard</b> <b>Danger of death</b>  Do not remove any panels from incubator. Do not allow the incubator to become wet.
 <b>HOT SURFACES</b>	<b>Danger of burning</b> <b>Risk of injury</b>  The glass door and inner chamber reach 200 °C during sterilisation. Do not force the door open during sterilisation.
 <b>STABILITY HAZARD</b>	<b>Stability hazard</b> <b>Risk of injury</b> <b>Damage to unit</b>  Do not place the unit too close to the edge of a bench. Do not lean on the door when open.
 <b>LIFTING HAZARD</b>	<b>Lifting hazard</b> <b>Risk of injury</b> <b>Damage to unit</b>  Lift with 4 people 95 kg Observe safe handling regulations

## 2 DESCRIPTION

CO<sub>2</sub>CELL Comfort incubators are fitted with the latest generation of programmable controller, ensuring precise control of temperature and CO<sub>2</sub> levels.

Accurate and stable heating throughout the entire chamber is ensured by the unique MMM designed five sided direct heating element. In addition a separate independently controlled door heater is fitted to ensure that the inner glass door is free from condensation.

The design of these element profiles promote natural convection of the air within the chamber, ensuring even temperature and gas distribution throughout the chamber.

CO2CELL Comfort incubator has extra heaters that allow high temperature 200 °C dry sterilisation of the incubator chamber.

## 2.1 CONSTRUCTION

The inner chamber is made from 316 grade stainless steel. It is deep drawn from one piece with no welds and is electro-polished, meaning that the inner surfaces are smooth and easily cleaned.

The removable shelves, racking and water tray are also made from stainless steel.

The outer housing is made from stainless steel and powder coated with anti-bacterial biocide paint.

## 2.2 DOORS

The outer door has a heater on its inner face. This door is an integral part of the temperature control system and must be closed for the incubator to function normally.

The door is hinged on the right hand side. Left hand opening is only available as an option at the point of ordering, retro-fitting is not possible.

When this door is open, the CO<sub>2</sub> valve is closed and heater power is reduced to prevent over shoot of operating conditions. The door is linked to the controller alarm system.

⇒ **Section 6.3**

On the Comfort 190S incubator, 2 magnetic solenoid locks prevent the outer door from being opened while the incubator is in a high temperature sterilise cycle.

An inner glass door seals against a thermoplastic elastomer gasket. This allows viewing of the samples within the chamber without disturbing the temperature or atmosphere of the chamber.

The incubator can be optionally equipped with a multi-door. These multi-doors improve temperature and CO<sub>2</sub> recovery after a door opening. Multi-doors can be retro fitted.

⇒ **Section 10.**

## 2.3 CONTROL SYSTEM

The colour LCD touch screen display allows the user to easily see operating conditions and to alter settings through icon based menus.

Software controlled PID loops constantly monitor temperature and CO<sub>2</sub> values, making automatic adjustments to keep the chamber atmosphere within limits.

The controller is equipped with a built in feature that logs incubator data directly to a removable SD card. This

data is in Excel format, making it easy to view with a PC. ⇒ **Section 7.**

A RS 232 serial port is fitted as standard. This allows you to connect the incubator to a PC so that you can remotely access the SD card data. PC software is required to do this. Contact your dealer or MMM directly for advice.

Other optional communication options are Ethernet PC interface and 4-20 mA retransmit. ⇒ **Section 10.**

## 2.4 CO<sub>2</sub> SENSOR

CO<sub>2</sub> is measured and controlled using a highly accurate infra-red sensor. This sensor remains practically drift free between calibration periods.

The sensor is not mounted within the chamber; instead a small pump passes the chamber atmosphere through the sensor.

The sensor does not have to be removed during high temperature sterilisation.

## 2.5 DIAGRAMS

### 2.5.1 OUTER VIEW

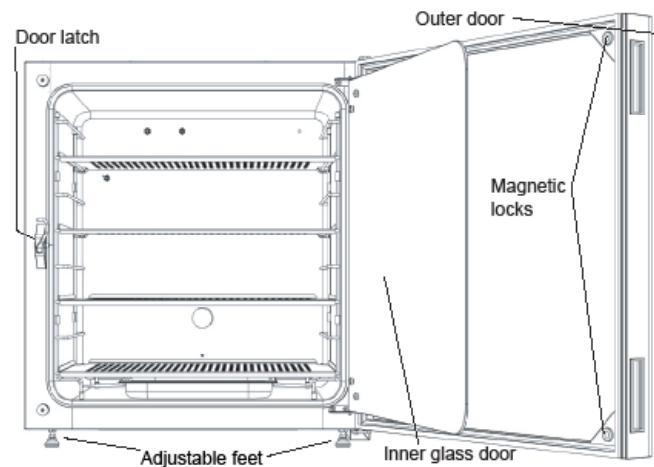

### 2.5.2 INNER VIEW

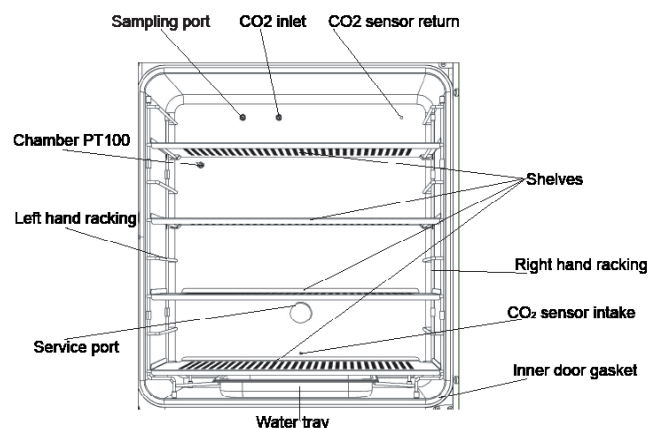

### 2.5.3 REAR CONNECTIONS

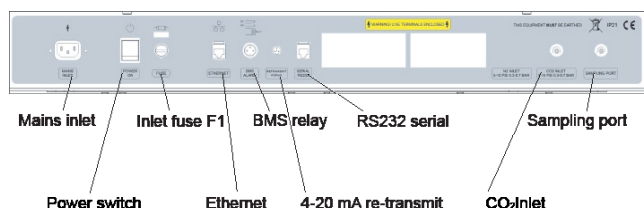

## 3 DELIVERY, TRANSPORTATION AND STORAGE

### 3.1 UNPACKING

Inspect the packaging for signs of transportation damage. Carefully undo the top of the cardboard packaging and gently slide the packaging over the incubator.

Inspect the incubator and inform the carrier immediately if there are any signs of transportation damage.

Remove any packaging material from within the chamber. Remove any protective coverings from the surfaces of the inner chamber.

Remove the operating manual and accessory kit from within the chamber. Keep these safe.

Please check that the accessory pack contains the following items. Contact your dealer with details of any shortages.

Comfort 190 accessory pack	Qty
Stainless steel perforated shelves	4
Shelf racking (left and right hand)	1 set
Racking support bar	1
Stainless steel water tray	1
Service port bungs	2
Formatted 2Gb SD card	1
Instructions for use	1
3.5 meter length of CO <sub>2</sub> tubing with HEPA filter	1
Hose clips	2
Test report	1
IEC mains power lead	1



### 3.2 LIFTING AND MOVING

These incubators are heavy. The weights are as follows:

Comfort 190 is 94,5 Kg

Comfort 190S is 104 Kg

Please refer to Manual Handling Policy of your organisation before attempting to lift the incubators.

  	<p><b>Risk of unit sliding or tipping.</b>  <b>Risk of injury by lifting heavy loads.</b>  <b>Risk of damage to the unit.</b></p> <p>Always lift using the handles on the outside of the incubator.                  Lift with 4 people.                  Do not lift by using the door.</p>
---	--

### 3.3 STORAGE

**i** If the incubator has been in a cold location for a period then it needs to acclimatise to room temperature.

Move the incubator to its final location and wait for 4 hours before start up. This will allow any condensation that may have formed to dry. It will also stop the incubator from overshooting temperature set point.

## 4 INSTALLATION

### 4.1 LOCATION AND AMBIENT CONDITIONS

**i** The incubator can be placed on a table or worktop. Please ensure that the site is sufficiently strong enough to carry the weight of the incubator.

MMM do not recommend placing the incubator directly on the floor as this increases the risk of contamination.

Wheeled platform forms are available that lift the incubator off the floor. Alternatively two incubators can be stacked using the stacking kit. ⇒ **Section 10.**

Correct location of an incubator is very important. The incubator is designed to work in a typical laboratory environment.

For good performance the ambient conditions should be at least 6 °C below the working temperature.

E.g. for a set point of 37.0 °C the ambient temperature must not exceed 31.0 °C.

If the difference between the set point and ambient temperatures is less than 6.0 °C then the set point can be exceeded and temperature fluctuation will occur.

Our performance data was produced at the ideal ambient condition of 25.0 °C. For best performance the ambient temperature should not drastically exceed this figure.

Maximum ambient humidity is 70 % rH, non-condensing. Condensation can occur within the chamber if this figure is exceeded.

A poorly located incubator can experience temperature fluctuations, poor cell growth and contamination of cell cultures. These guidelines will ensure best performance:

- The incubator should be sited on a flat, even surface.
- It should be in a well ventilated and dry area, but not sited directly in the path of ventilation ducts.
- It should be free from vibration.
- It should be kept away from heat sources e.g. radiators, heating pipes, refrigeration plant.
- It should not be in direct sunlight.
- To avoid contamination it should not be placed directly on the floor.
- Allow sufficient distances between adjacent equipment.
- There should not be big swings in ambient temperature.

Leave a clearance of 50 mm from each side and 100 mm from the rear.

Level the incubator by adjusting the two front feet. Place a small spirit level on the centre position of the middle shelf as a guide.

When it is level, secure the feet by tightening the lock nuts with a 10 mm spanner.

## 4.2 SHELVES AND USABLE SPACE

Each incubator is supplied with 4 perforated stainless steel shelves. The shelves locate into removable stainless steel racking. The shelves incorporate an anti-tilt mechanism, stopping the shelves from being pulled out too far.

Each shelf measures 690 mm wide by 390 mm deep. The minimum spacing between shelves is 80 mm. There are 8 possible positions for the shelves.

The shelves and racking can be left in place during sterilisation.



The usable space within the incubator is the volume in which the conditions are within our published data.

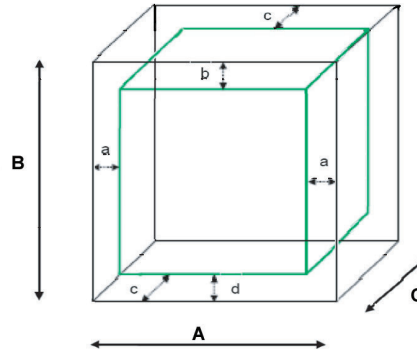

A, B, C = Internal dimensions

a = distance from left and right wall = 70 mm

b = distance from top = 70 mm

c = distance from front and back wall = 70 mm

d = distance from base = 70 mm

For practical purposes this is the perforated area on each shelf.

- Do not place any samples outside of this space.
- Do not over fill each shelf.
- Allow sufficient room between samples to allow for airflow.
- Do not use the top shelf for very deep samples.

## 4.3 WATER TRAY

A stainless steel water tray is supplied which allows the incubator to provide 90 %rH.

Place the tray on the floor of the incubator, locating it with the side racking.

Carefully fill the tray with 1.5 litres of distilled, sterilised water.

MMM recommend that you clean and refill the tray every week.

Any spillages within the chamber should be removed and cleaned immediately. Water left on the chamber floor will cause condensation to form.



Under no circumstances should any equipment be placed in the water tray or on the chamber floor.

Remove the water tray before moving the incubator.

Empty the water tray if the incubator is switched off, otherwise condensation will occur.



## 4.4 GAS CONNECTION

	<b>Risk of injury. Compressed gas. Risk of damage to unit.</b>
	<b>Observe relevant regulations for handling CO<sub>2</sub> Risk of asphyxiation. Site must have adequate ventilation.</b>
	<b>Risk of CO<sub>2</sub> poisoning. Site must have adequate ventilation.</b>

**i** The incubator is designed for use with CO<sub>2</sub> of 99.5 % purity. Input pressure greater than 1.0 bar (15 psi) will damage the incubator so a pressure reducing valve (PRV) must be used.

The CO<sub>2</sub> inlet to the incubator is via a 4 mm barbed push fitting.

PRV's with the correct fittings and other gas accessories can be supplied by MMM. ⇨ **Section 10.**



For correct connection of CO<sub>2</sub>, follow these steps in order:

- 1) Connect the supplied tubing and HEPA filter to the gas supply.
- 2) Fully close the PRV.
- 3) Open the main valve on the gas bottle or central supply.
- 4) Adjust the PRV pressure of the gas supply to between 0.3 bar and 0.7 bar (4.5 to 10 psi).
- 5) Close the main valve on the gas bottle / central supply.
- 6) Connect the other end of the tubing to the incubator CO<sub>2</sub> inlet. Secure with the supplied clip.

Repeat these steps whenever you change the CO<sub>2</sub> bottle or supply.

Turn off the main valve and disconnect from the CO<sub>2</sub> supply if the incubator is to be unused for extended periods.

## 4.5 ELECTRICAL CONNECTION

	<b>Risk of injury. Risk of damage to unit. Observe correct mains supply voltage.</b>
	<b>Risk of electrical shock. Do not connect with wet hands. No user serviceable parts. Do not remove service panels.</b>
	<b>Disconnect unit in an emergency.</b>

Before connecting the incubator, check that the electrical supply corresponds with the values on the incubator data plate. If in doubt consult a qualified electrician.

The incubator is designed to operate from a single phase electrical supply of: 230 V AC ±10 % 50/60 Hz.

This incubator **MUST** be connected to a protective earthed supply.

Further details can be found in the technical data.

⇨ **Section 15.1.**

Plug the supplied power lead into the IEC connector on the rear of the incubator.

Plug the other end of the IEC lead into the electrical supply.



In an emergency you may need to isolate the incubator from the electrical supply by disconnecting the mains supply plug. Make sure that the mains supply plug is easily accessible.

# 5 GETTING STARTED

## 5.1 START UP

Insert the pre-formatted SD card (supplied) into the slot to the right of the controller.

Turn on the unit using the power switch on the rear panel. The controller will boot up and perform a self-check.

## 5.2 SETTING TIME AND DATE

After the controller has booted up, the time and date screen will be shown. Time and date are shown in the format hh:mm:ss and dd/mm/yy.

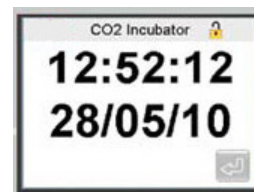

If the time and date is correct

press: 

Proceed to step 5.3

If the time and date are incorrect press the time display. This screen will be shown:



Use the touch screen to enter the correct time.

Press  to confirm selection.

Repeat these steps for setting the date.

### 5.3 FACTORY PRESETS

The following values are preset to allow you to work straight away:

Parameter	Value
Set Point, Temperature	37.0 °C
Set Point, CO <sub>2</sub>	5.0 %
High temperature alarm	+1.0 °C relative to set point
Low temperature alarm	-1.0 °C relative to set point
High CO <sub>2</sub> alarm	+1.0 °C relative to set point
Low CO <sub>2</sub> alarm	-1.0 °C relative to set point
Door open alarm timer	30 seconds

#### MAIN DISPLAY

The main screen shows chamber set points (SP) and process values (PV). It also shows the status of any alarm and has touch screen buttons for accessing further functions.

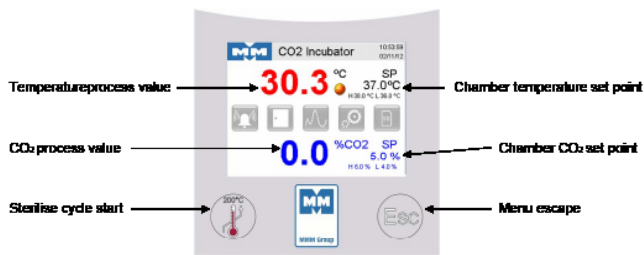

### 5.4 CHANGING TEMPERATURE SET POINTS AND HIGH / LOW ALARMS

To change the temperature set point, touch this area of the

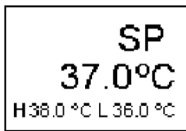

main screen:

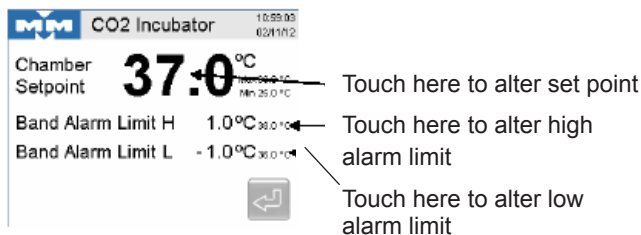

Use the keypad to change the set point. Maximum set point is limited to 60.0 °C

Minimum set point is limited to 25 °C

Press to confirm selection.

The high and low alarm limits are relative to the chamber set point.

For instance if the set point is 37.0 °C and the high alarm limit is + 1.0 °C then the alarm will trigger at 38.0 °C.

If the set point is changed to 36.5 °C then the high alarm will trigger at 37.5 °C.

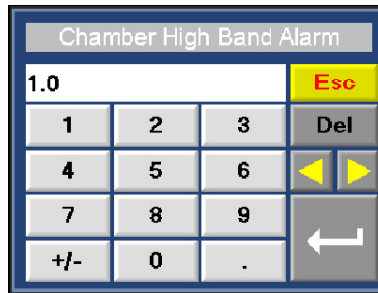

Use the keypad to change the high alarm threshold.

Press to confirm selection.

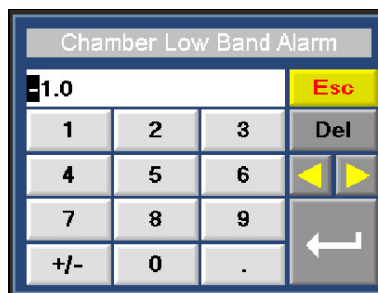

Use the keypad to change the low alarm threshold.

This must be negative so remember to first

press

Press to confirm selection.

### 5.5 CHANGING CO<sub>2</sub> SET POINTS AND ALARM THRESHOLDS

To change the temperature set point, touch this area of the

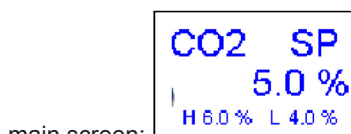

main screen:

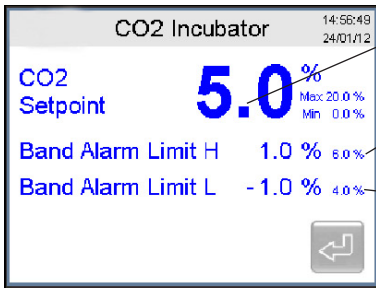

Touch here to alter set point

Touch here to alter high alarm limit

Touch here to alter low alarm limit



Use the keypad to change the set point.

Maximum set point is limited to 20.0 %

Minimum set point is limited to 0.0 %

Press to confirm selection.



If the CO<sub>2</sub> set point is 0.0 % then CO<sub>2</sub> control is disabled.

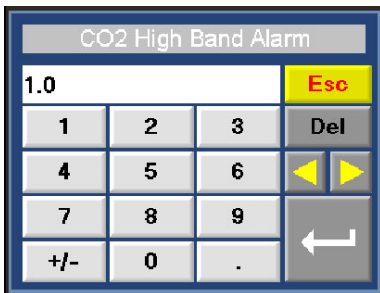

Use the keypad to change the high alarm threshold.

Press to confirm selection.

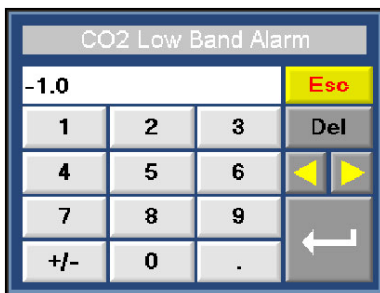

Use the keypad to change the low alarm threshold.

This must be negative so remember to first

press

Press to confirm selection.

## 5.6 ALARM STATUS SCREEN



The alarm icon gives a visual indication of alarm status.

Pressing the alarm icon opens the alarm status screen:

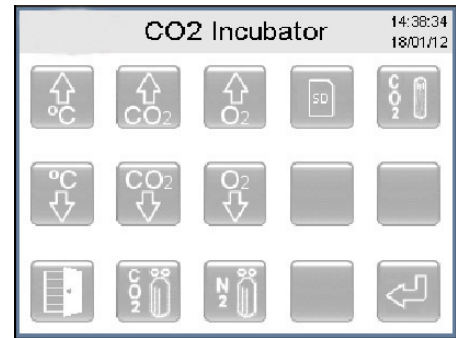

High temperature alarm



Low CO<sub>2</sub> alarm



Low temperature alarm



Door open alarm



High CO<sub>2</sub> alarm



SD card alarm



Low gas pressure alarm

In an alarm condition an audible buzzer sounds and the

alarm icon changes to red.

Press this red alarm icon and the alarm status screen will show the corresponding alarm will in red.

For instance this shows high temperature alarm condition:



Pressing this will mute the alarm.

The alarm is now acknowledged and the icons show this by

changing to yellow:

The icons remain yellow for as long as the incubator is in an alarm condition.

This process is the same for all alarms.

As an additional warning the colours of the process values change during alarm condition.

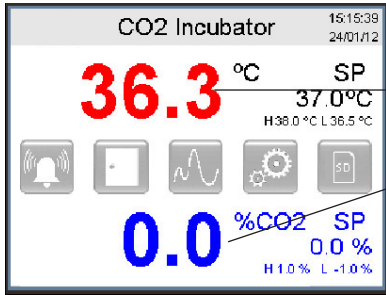

The temperature process value has changed colour from black to red.

The CO<sub>2</sub> process value will change colour from blue to red when it enters alarm conditions.

## 6 OTHER FEATURES

### 6.1 GRAPHICAL DISPLAY

The controller has a built in feature that allows the user to view graphs of both temperature and CO<sub>2</sub>. It stores a minimum of 3 days of graphical data. When the internal memory is full it will over-write the oldest data first.

Graphs are only stored while the unit is powered.

This feature is independent of the SD data logging function.  
⇒ **Section 7.**

On the main screen press the graph symbol:



The graph menu opens:  
Choose which graph you wish to view

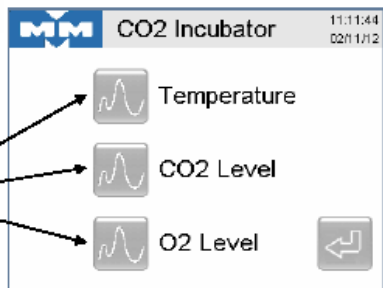

In this instance we are viewing the temperature graph:

Press the y-axis limits.

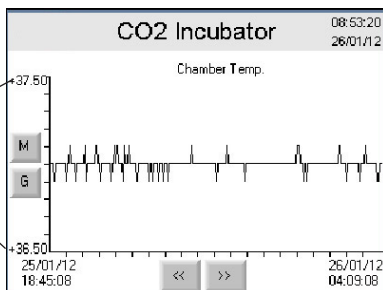

The values can be changed using the keypad.

Press **M** Use **<<** **>>** to view the temperature stability against time.

To return to the Main Screen press the escape button



The CO<sub>2</sub> graph is viewed in the same manner.

### 6.2 UTILITY MENU

On the main screen press the utility menu symbol:

The utility menu combines all of the incubator settings menus in one place. You will already be familiar with some of these.

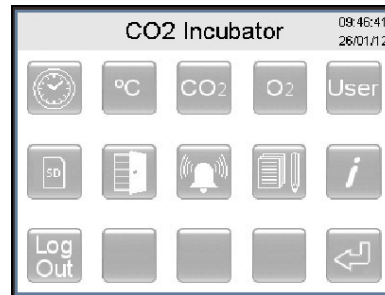

Clock menu.

⇒ **Section 5.2**



Temperature menu.

⇒ **Section 5.5**



CO<sub>2</sub> menu.

⇒ **Section 5.6**



User security menu.

⇒ **Section 6.6**



SD card menu.

⇒ **Section 7**



Door alarm menu.

⇒ **Section 6.3**



Alarm status menu.

⇒ **Section 5.7**



Historical event log.

⇒ **Section 6.5**



Incubator information.

⇒ **Section 6.4**



User log out.

⇒ **Section 6.6**

## 6.3 DOOR ALARM MENU



Press the door icon:

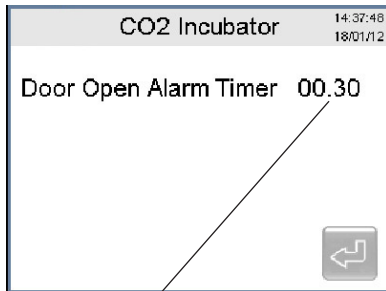

The door has a magnetic switch that senses when the door is opened.

The door icon turns red as soon as the door is opened. After a set time the alarm will sound. This can be muted in the alarm status menu. → **Section 5.7**

This delay can be changed by pressing here. The format is mm:ss.

## 6.4 INCUBATOR INFORMATION



Press the info icon:

The information screen shows the incubator Serial Number as well as what release of software / firmware the controller is using. This information is important should you require any assistance from MMM.

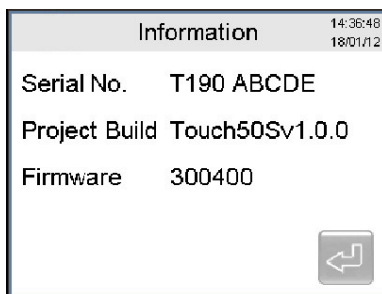

## 6.5 HISTORICAL EVENT LOG

The controller has a built in feature that displays the time and date of 100 historical events.

When 100 events have been logged the oldest event is over-written.

Events include: alarms, alarm acknowledgment, door open/closed, power on/off, SD card insertion/removal, user logon/logoff, sterilise cycle start/finish/abort.



Press the event log icon: Press to scroll through the events.

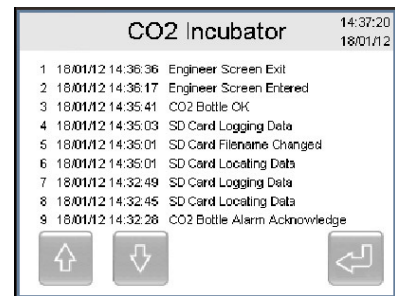

## 6.6 USER SECURITY



This incubator allows for a user name and password to be programmed.

This stops any unauthorised changes to incubator settings.

### 6.6.1 ENTERING A USER NAME AND PASSWORD

To enter a user name and password press the User icon:

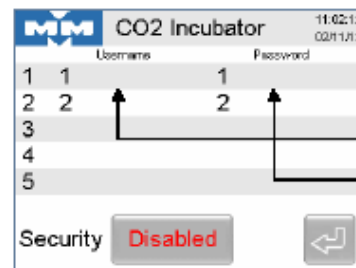

Press here on Line 1 to enter user name.

Press: to save.

Then press here to enter password.

Press: to save

The user name and password are now saved.

### 6.6.2 ENABLING SECURITY

**Disabled**

Press the security status icon:

**Enabled**

The icon changes state to:

Security feature is enabled and you are now logged on as

shown by the open padlock symbol:

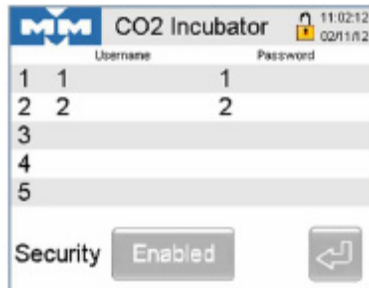

### 6.6.3 LOGGING OUT

On the utility menu screen, press and hold the log out icon:



You are logged out and the padlock icon is now locked: 

No changes to the incubator can be made without logging back in.

**For the Comfort 190S incubator only:**

At this point the magnetic door locks are activated, stopping any unauthorised access to the incubator.

### 6.6.4 DISABLING SECURITY

Press the utility icon: 

When prompted, enter the user name and password.

To disable security press: 

Icon changes to: 

Security is now disabled.

## 7 SD CARD DATA LOGGING

 The incubator is supplied with a 2 GB SD card. This SD card is pre-formatted to work with the controller's operating system.

 **Only cards supplied by MMM can be used. Using any other type of card will not work with the incubator and will cause the controller system to crash.**

The controller can log to a removable SD card located on the front of the incubator.

Every 30 seconds the controller records the following data to the SD card:

- Date & Time
- Chamber temperature set point (SP);
- Chamber temperature process value (PV)
- Door set point (SP);
- Door process value (PV)
- Door set point (SP);
- Door process value (PV)
- CO<sub>2</sub> set point (SP);
- CO<sub>2</sub> process value (PV)

Any events are also logged in a separate file.

The data is stored in Excel format making it very easy to read and use the data with a PC.

Data is only logged when the incubator is powered; however data is not lost when power is removed.

### 7.1 START LOGGING

If the card is already inserted when the incubator is powered up then logging will start automatically.

If the SD symbol is grey  then the incubator is

logging. If it is red then it is not logging. 

Press the red SD icon  in the Utility Menu. The Status screen will state that the card is removed.

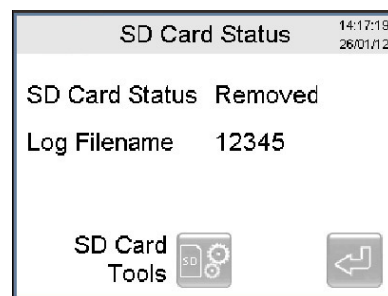

Insert the SD card into the slot to the right of the controller (label side closest to controller).

The SD Card status screen shows that the controller is locating the data and preparing to log. This can take from a few seconds to a few minutes depending on data file size. Please be patient.



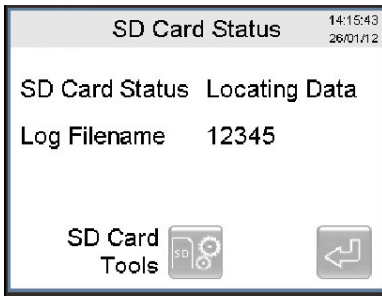

When the controller has located the log file the status screen shows that it is logging data:

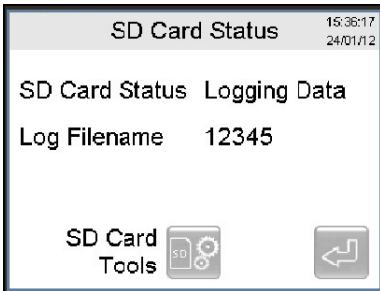

Press  to return to the main screen

## 7.2 CHANGING FILENAME

You can easily change the filename to start a new log.

Press the filename on the screen, in this case **12345**. Enter a new file name, in this case 67890.

Press  to store selection.



Press  to confirm the new filename:

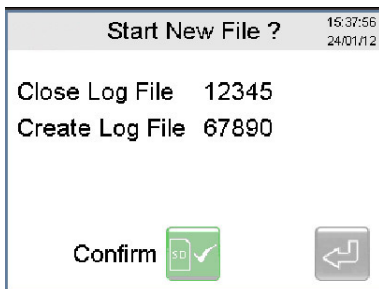

The controller will then locate the new file and start logging:

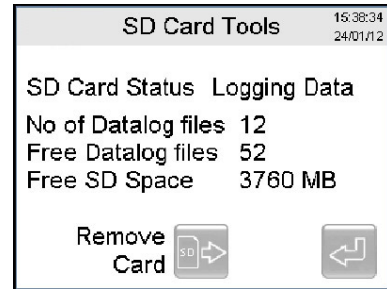
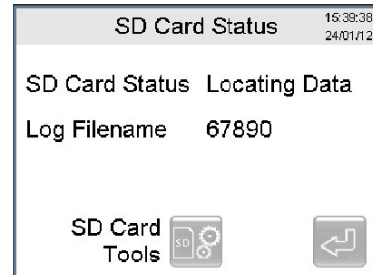

## 7.3 RETRAIT DE LA CARTE SD



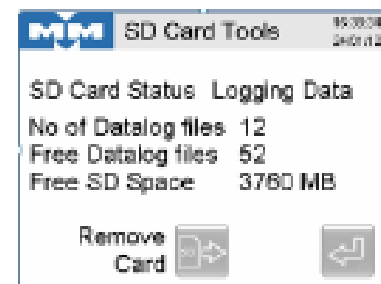

Avant de retirer la carte SD, il conviendra de toujours procéder comme indiqué ci-dessous. Tout non-respect de ces consignes aura pour conséquence une dégradation, voire une perte définitive des données.

On the SD Card status screen press the SD card tools icon:

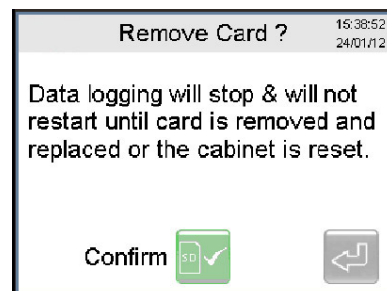

Press the remove card icon: 



Press the confirm icon: 

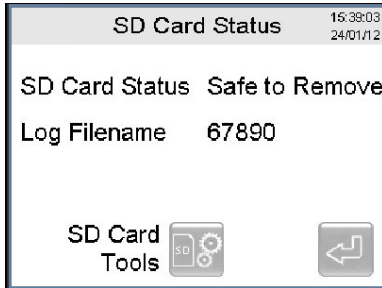

It is now safe to remove the SD card.

When the card is removed then the screen will automatically change to this:

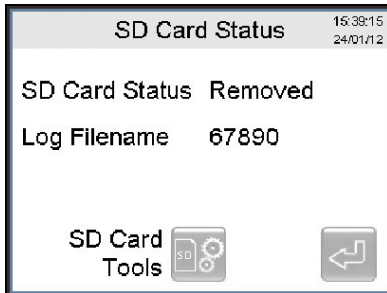

## 8 HIGH TEMPERATURE STERILISATION

	<p>Risk of damage to unit. The Comfort 190 is not intended to be used as an autoclave and must not be used for sterilising any other equipment.</p>
	<p>Only the shelves, racking and water tray can be left inside the incubator during sterilisation.</p>
	<p>Risk of injury. Risk of burning. Internal surfaces reach 200 °C</p>

The Comfort 190S incubator is equipped with a high temperature sterilisation function. This raises the chamber temperature to 200 °C for 2 hours.

Independent evaluation has shown this to be effective against all spores and bacteria commonly associated with laboratory incubator contamination.

### 8.1 PREPARATION

Make sure that you have entered a user name and password as shown in → **Section 6.6.1**

Empty and dry the water tray. This can be placed back inside the incubator.

Clear any samples or equipment from the shelves.

The shelves and racking can be left in place during the sterilisation cycle.

### 8.2 STARTING THE CYCLE

Press and hold the sterilise button for 5 seconds:



The first sterilise cycle check list opens:

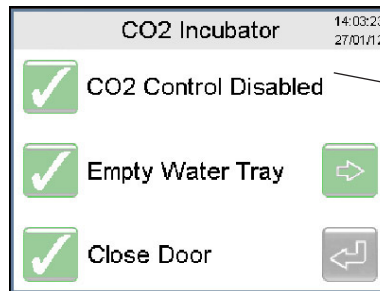

Automatically carried out by controller.

When you have emptied the water tray, place it back inside the chamber and close the doors.

Press the grey tick to acknowledge this:

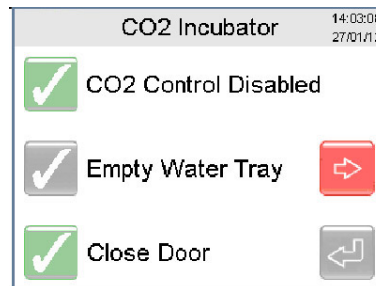

All checks are now complete.

Press  to proceed.

This shows that the door locks have activated and that Operator 6 is logged on.

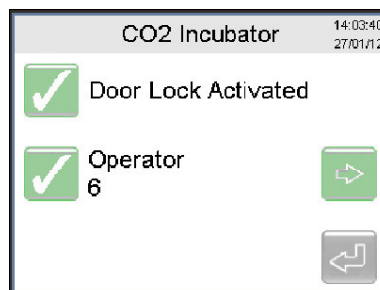

Press  to proceed.



### 8.3 STERILISE CYCLE



The sterilise cycle has now started. A temperature graph is plotted to show the duration of the cycle. The y-axis automatically changes its scale to 205 °C

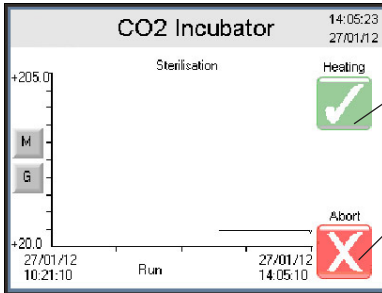

This shows that the heaters are operational

Abort cycle icon → Section 8.5

The sterilise cycle consists of 3 distinct phases. They are:

- **Heat up.**

During the heat up phase, maximum power is applied to the heating elements. CO<sub>2</sub> control is disabled to protect the sensor and the door locks are activated.

- **2 hour dwell.**

The dwell phase starts once the chamber temperature reaches 200 °C.

Heater power is automatically reduced to regulate the temperature at 200 °C.

- **Cool down.**

After 2 hours at 200 °C power is removed from the heaters and the cooling phase begins. The chamber is allowed to cool naturally. When the chamber temperature reaches 38 °C the door locks are deactivated and CO<sub>2</sub> control is enabled.



The time taken for a full sterilisation cycle is dependent on the cool down phase.

As cooling relies on the heat loss through the chamber walls the time taken is affected by the location of the incubator and the ambient temperature.

So, an incubator placed under a worktop will take longer to cool than a freestanding incubator on a worktop.

We recommend that you carry out the sterilise cycle at the end of a working day. That way, when you return to work in the morning the incubator will be ready for you to use.

This sterilise cycle graph shows a typical start to finish duration of 8 hours:

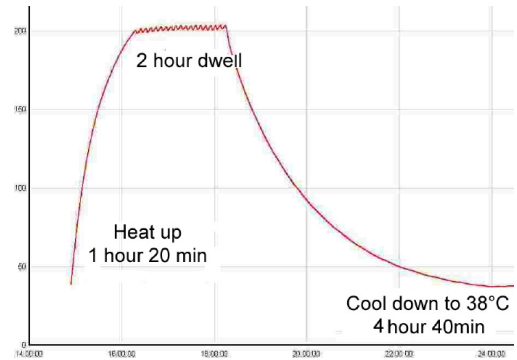

### 8.4 COOLING PHASE

After the 2 hour dwell is completed the incubator goes into the cooling phase of the sterilisation cycle.

The doors are locked during this phase. CO<sub>2</sub> control is disabled.

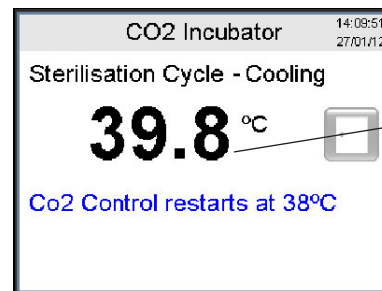

The chamber temperature is displayed

The cooling phase ends once the temperature falls below 38.0 °C

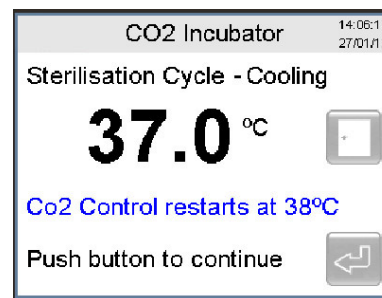

Press  to continue to main screen.

## 8.5 ABORTING THE STERILISE CYCLE

Should you need to stop the sterilise cycle for any reason

Abort



then press the abort icon:

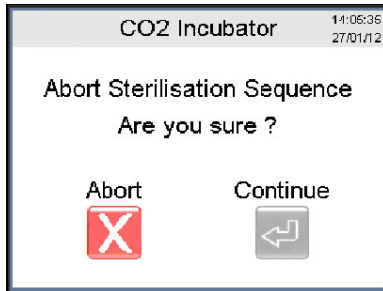

Press The incubator now enters the cooling phase.

⇒ Section 8.4.

## 9 ERROR MESSAGE SCREENS

In the event of a fault condition the control system may warn you with various error messages.

	<p><b>Chamber probe failure</b></p> <p>Chamber probe is out of limits and has failed.</p> <p>Contact MMM Service immediately</p>
	<p><b>Base probe failure</b></p> <p>Base probe is out of limits and has failed.</p> <p>Contact MMM Service immediately</p>

	<p><b>Door probe failure</b></p> <p>Door probe is out of limits and has failed.</p> <p>Contact MMM Service immediately</p>
	<p><b>SD card critical error</b></p> <p>SD has not been safely removed.</p> <p>Press and hold  Switch power off, insert card and switch power on again.</p> <p>If problem persists contact MMM Service</p>
	<p><b>SD card removal error</b></p> <p>Repeat the steps above to fix this.</p>
	<p><b>Boot screen error</b></p> <p>Take a picture of the screen. Turn power off for 1 minute.</p> <p>If problem persists contact MMM Service with details of picture.</p>

## 10 OPTIONS

### 10.1 VOLT FREE ALARM RELAY (BMS)

All touch screen incubators are fitted as standard with a volt free changeover relay for connection to a building maintenance system (BMS).

This relay changes state whenever the incubator is in an alarm condition. The relay changes back to its original state once the alarm condition clears.

The connections are as shown below:

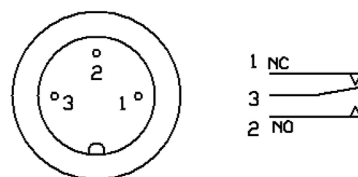

SOLDER VIEW OF CABLE SOCKET

## 10.2 4 - 20 mA RETRANSMISSION (RETX)

This is an option that must be specified at the point of ordering.

This feature allows the chamber temperature and CO<sub>2</sub> process values to be retransmitted as a 4 - 20 mA signal. This 4 - 20 mA signal can be connected to external equipment for independent validation of incubator performance.

The incubator will be supplied with a pre-wired 3 metre cable socket.

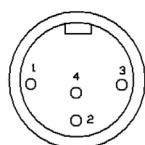

PIN 1	RED	TEMPERATURE +4-20mA
PIN 2	GREEN	TEMPERATURE 0VDC
PIN 3	BLUE	CO <sub>2</sub> + 4-20mA
PIN 4	YELLOW	CO <sub>2</sub> 0VDC

SOLDER VIEW  
OF CABLE SOCKET

The temperature signal is scaled as: 4 mA = 0 °C;  
20 mA = 250 °C

The CO<sub>2</sub> signal is scaled as: 0 mA = 0 % CO<sub>2</sub>;  
20 mA = 20 % CO<sub>2</sub>

## 10.3 RS 232 SERIAL COMMUNICATION (232)

RS 232 communication is fitted as standard. This allows for the SD card data to be remotely accessed and downloaded.

A PC with a serial (COM) port is required. Software is required. Please contact MMM limited for further details.

## 10.4 ETHERNET COMMUNICATION (ETH)

This is an option that must be specified at the point of ordering.

An Ethernet port can be fitted to connect the incubator to a network. This allows the SD card to be remotely accessed and for the incubator screen to be displayed on a PC.

Connection to a PC network is required. Contact your IT manager to see if this possible.

Instructions will be sent separately when this option is ordered.

## 10.5 MULTI-DOOR (8ID)

This can be retro fitted.

The inner glass door can be replaced with a multi-door. This has 8 smaller glass doors in a stainless steel frame.

By only opening one small door to access the sample you require, less heat, humidity and CO<sub>2</sub> are lost.

This improves recovery of the chamber back to ideal conditions and reduces the amount of CO<sub>2</sub> used.

# 11 ACCESSORIES

This is the list of some of the accessories currently available.

Please contact MMM if the part you require is not listed.

PTSK	Stacking kit for 2 x Comfort 190
PTST1	Wheeled platform for Comfort 190
PRV	Single stage CO <sub>2</sub> pressure reducing valve
PRV2	Two stage CO <sub>2</sub> pressure reducing valve
RO6	In line CO <sub>2</sub> reducing valve with gauge (0.1 to 2 bar)
PNEU	Automatic change over unit for two CO <sub>2</sub> cylinders
TYGON	Tygon gas tubing, per meter

# 12 CLEANING



**Electrical hazard. Do not spill water or cleaning fluids over the inner or outer surfaces.**



**Disconnect before cleaning.**

**Completely dry the unit before reconnecting the power.**

## 12.1 OUTER SURFACES

Always disconnect the incubator before cleaning.

It is recommended that the exterior of the incubator regularly wiped clean. Use a non-abrasive soft cloth dampened with a warm soapy water solution.

Make sure the exterior is thoroughly dry after cleaning.

## 12.2 INNER SURFACES

It is advisable to clean the chamber regularly.

Use a 70 % isopropanol 30 % distilled water solution. Apply using a sterile cloth so as not to introduce any contamination.

Never use any of the following:

- Any chlorine based detergents or bleaches.
- Any acidic cleaning agents.
- Sodium Azide
- Iodine
- Ferric Chloride

Wipe over the inner surfaces of the stainless chamber, all the shelves including the underside of the shelves, the shelf racks and the water tray.

The shelves, racking and water tray can be sterilised in an autoclave if required.

Clean the glass door and the inner gasket seal.

Clean the inner stainless steel surfaces of the outer door and the outer door gasket.

## 12.3 OXIDATION AT HIGH TEMPERATURE (COMFORT 190S ONLY)

When operated at 200 °C the action of atmospheric oxygen may cause discolouration of the stainless steel surfaces. This natural oxidation is not detrimental to the quality of the incubator and is completely harmless.

# 13 SERVICE

## 13.1 WARRANTY

All MMM Comfort 190 incubators are supplied with a two year manufacturer's warranty from the date of installation.

To register your warranty, please fill in the User Guarantee Registration Card and post to MMM Limited or to your local distributor.

## 13.2 PREVENTATIVE MAINTENANCE

This Culture Safe CO<sub>2</sub> Incubator is built to last for many years, but to ensure that the unit continues to perform to the highest level we recommend that you purchase a preventative maintenance contract from MMM. The incubator should be calibrated annually.

## 13.3 RETURNING A UNIT

Should your incubator require repair or maintenance then contact your local distributor in the first instance.

Returns to MMM will only be accepted with prior authorisation from the Service Department.

We recommend that you keep all packaging.

When returning a unit please include the following information:

- Incubator model and serial number
- Date of purchase
- Authorisation number
- Name of local distributor if not purchased from MMM
- A detailed description of the fault (we can never have too much information)
- Where was the incubator located
- Contact details of the person who reported the fault
- A completed decontamination certificate (plus a copy faxed through in advance).



MMM cannot accept any returns without a completed decontamination certificate.

# 14 DISPOSAL

The incubator must not be disposed of at public waste collection points. It must only be disposed of by licensed waste recycling companies.

Contact MMM for further information regarding WEEE regulations.

# 15 TECHNICAL INFORMATION

## 15.1 TECHNICAL DATA

TEMPERATURE MANAGEMENT		
Range	°C	5 °C above ambient to 60 °C
Control	°C	0.1 °C
Stability	°C	±0.1 °C @ 37.0 °C
Uniformity	°C	±0.25 °C @ 37.0 °C
Door recovery,30 s opening	minutes	13

<b>CO<sub>2</sub> MANAGEMENT</b>		
Range	% CO <sub>2</sub>	0-20 %
Control	% CO <sub>2</sub>	±0.1 %
Stability	% CO <sub>2</sub>	±0.2 %
Uniformity	% CO <sub>2</sub>	±0.2 %
Door recovery, 30 s opening	minutes	6
CO <sub>2</sub> sensor type	NDIR	
CO <sub>2</sub> inlet pressure	Bar	0.3 to 0.7
CO <sub>2</sub> inlet connection type	4 mm push fit barbed type	
<b>HUMIDITY MANAGEMENT</b>		
Humidity control type	Passive	
Range	% rH	90 % ± 5 %
Door recovery, 30 s opening	minutes	50
<b>ELECTRICAL DATA</b>		
Nominal voltage 50/60 Hz	V	230 1N ~PE
Power; Comfort 190	W	380
Power ; Comfort 190S sterilise cycle	W	1800
Power consumption	kWh	0.058
Main fuse F1; Comfort 190	6.3 A / 6.3 x 32mm / 250 V / TT	
Main fuse F1; Comfort 190S	10 A / 6.3 x 32mm / 250 V / TT	
<b>EXTERIOR DIMENSIONS</b>		
Width	mm (inches)	765 (30.1)
Height	mm (inches)	862 (34)
Depth	mm (inches)	734 (28.9)
Wall clearance, rear	mm (inches)	100 (3.94)
Wall clearance, side	mm (inches)	50 (1.97)
<b>INTERIOR DIMENSIONS</b>		
Width	mm (inches)	632 (24.9)
Height	mm (inches)	686 (27)
Depth	mm (inches)	440 (17.3)
Volume	Litres (cu. ft.)	190 (6.7)
Number of shelves	4 shelves. Maximum of 8	
<b>SHIPPING DIMENSIONS</b>		
Width	mm (inches)	925 (36.4)
Height	mm (inches)	1080 (42.5)
Depth	mm (inches)	850 (33.5)
<b>WEIGHT</b>		
Comfort 190, Net	kg (lbs)	94.5 (208)
Comfort 190S, Net	kg (lbs)	104 (229)
Comfort 190, Shipping	kg (lbs)	109 (240)
Comfort 190S, Shipping	kg (lbs)	117.5 (259)

## 15.2 DIMENSIONAL DRAWINGS

