

## Integral Dental Unit Chair Operation Manual *(technical manual)*



**Ningbo Runyes Medical Instrument Co., Ltd.**

Add: 032 Building, No. 456, Tonghui Road, Jiangbei Investment  
& Pioneering Park C, 315033, Ningbo, China

Tel: +86-574-27709922 Fax: +86-574-27709923

Email: runyes@runyes.com <http://www.runyes.com>



**Shanghai International Holding Corp. GmbH (Europe)**

Eifestr. 80, 20537 Hamburg, Germany

Tel: +49-40-2513175 Fax: +49-40-255726

## Important information

This instruction is the installation, operation and maintenance manual of Care Series Dental Unit. Please read carefully before using the machine.

Care series products include following models:

Model	Type	Model	Type
Care-11U	Up Mounted /Swing type	Care-11D	Down Mounted /Swing type
Care-22U		Care-22D	
Care-33U		Care-33D	

Without the written permission of Runyes Medical Corporation, any forms of modification ,spread, reprint and sales of this instruction is forbidden.

Runyes company reserves the final explanation right, illustration right and changing right of this instruction.

### Attention

**Product Name:**

**Product Model:**

**Serial no:**

**Date of manufacture:**

**Voltage:**

Caution: power must be connected with reliable grounding line.

Warning: Please cut off the power supply and the gas supply before cleaning or maintaining.

Tips: Please cut off the power supply and the gas supply after work.

Suggestions:

1. Please don't install or use this device near water or when you are wet.
2. Please place the device on firm, clean and level floor(uneven floor will affect the device's performance or even cause accident).
3. Please install this device on safe place in case that someone steps on the power cord.
4. Please install the device in clean, dry, ventilated and cool places.
5. If the device can't work normally, please read "Trouble shooting" in page 32 of this manual or you can contact supplier or us. We will solve the problem for you as soon as possible.

# Contents

P3	Icon description	P24	18.11 Ultrasonic Scaler(Optional)
P4	Precautions	P24	18.12 Main Water and Air Switch
P5	1 Summary	P24	18.13 Pipeline Cleaning Switch
P6	2 Environmental requirements	P24	18.14 Hanger Valve
P7	3 Technical Parameters	P24	19 Auxiliary Tray Slide-out Instrument Tray (Optional)
P7	4 Product Overview	P24	20 Foot Switch
P8	5 Layout Diagram	P25	21 Keypad
P9	6 Installation of Complete Equipment	P27	21.1 Key Operation and Settings Instructions
P9	6.1 Preparation	P29	22 Oral Lamp
P9	6.2 Installation of Treatment Unit	P29	23 Equipment Calibration
P11	Pbe-Stena Unit for Disassembling	P29	23.1 High/Low-Speed Air Turbine Handpiece Calibration
P12	8 Assembly of Model 33 Chair Frame	P29	23.2 High/Low-Speed Air Turbine Handpiece Calibration
P12	8.1 Installation of Backrest	P29	23.3 Three-Way Syringe Calibration
P12	8.2 Installation of PU Seat Cushion	P30	23.4 Dental Chair Calibration
P13	8.3 Installation of PU Backrest	P30	23.5 Side Box Level Adjustment
P13	8.4 Assembly of PU Headrest	P31	23.6 Water Bottle Pressure Adjustment
P13	9 Installation of Model 55 Side Box Top-Mounted Assistant Arm	P31	23.7 Balancing Arm Adjustment
P14	10 Installation of Model 55 Side Box Spittoon Assembly	P31	23.8 Instrument Tray Level Adjustment
P14	11 Circuit Board Interface Connection Instructions	P32	23.9 Swing Arm Tension Adjustment
P16	12 Installation of Light Pole, Light Arm, and Oral Light	P32	23.10 Spittoon Rotation Tension Adjustment
P16	13 Installation of Floor Box Piping	P32	23.11 Lamp Head Rotation Tension Adjustment
P16	14 Power Supply Installation	P33	23.13 Lamp Arm Force Adjustment
P17	15 Dental Chair Components	P33	24 Troubleshooting
P17	15.1 Model 11 Chair Frame	P33	24.1 No Power to Unit
P18	15.2 Model 33 Chair Frame	P33	24.2 Positioning Malfunction (No Movement Up or Down)
P19	16 Side Box Components	P33	24.3 Water in Air Lines
P19	16.1 Side Box Body	P33	24.4 Air in Water Lines
P19	16.2 Ceramic Basin, Rinse Water, and Flushing System	P34	24.5 Low Speed or Power in High-Speed Air Turbine Handpiece
P19	16.3 Water Temperature Display	P34	24.6 Dental Low-Speed Handpiece Not Rotating or Low Speed
P20	Model 11 Side Box Instructions	P34	24.7 Inadequate Suction in High-Power Suction
P20	Model 22 Side Box Instructions	P34	24.8 Inadequate Suction in Saliva Ejector
P20	Model 33 Side Box Instructions	P34	24.9 Spittoon Drainage Issues
P21	Model 55 Side Box Instructions	P35	24.10 Basic Troubleshooting
P22	16.4 Water Storage Bottle	P35	25 Maintenance and Care
P22	17 Assistant Arm	P35	25.1 Unit and Dental Chair Maintenance
P22	17.1 Three-Way Syringe	P35	25.2 High/Low-Speed Handpiece Maintenance
P22	17.2 Saliva Ejector	P36	25.3 Three-Way Syringe Tip Maintenance
P22	17.3 High-Power Suction	P36	25.4 High (Low) Power Suction Device Maintenance
P23	18 Instrument Tray	P36	25.5 Spittoon Drain Maintenance
P23	18.1 Instrument Tray Support Board	P36	25.6 Air Filter Regulator Maintenance
P23	18.2 Drive Air Pressure Gauge	P36	25.7 Water Filter Maintenance
P23	18.3 Left (Right) Air Brake Switch	P36	25.8 LED Lamp Head Maintenance
P23	18.4 Drive Air Regulator	P37	26 Cleaning, Sterilization, and Disinfection
P23	18.5 Water Flow Control Valve	P40	27 Waste Disposal
P23	18.6 Film Viewer (Optional)	P41	28 Circuit Diagram
P23	18.7 Three-Way Syringe	P42	30 Electromagnetic Compatibility
P23	18.8 High-Speed Air Turbine Handpiece	P43	31 Standard Packing List for Treatment Unit
P23	S*9 High-Speed Air Turbine Handpiece with "Air"		
P23	18.180 Dental Low-Speed Handpiece		

## Icon Description

	Attention: Failure to follow the instructions will lead to equipment damage.		Seat up key
	Warning: Failure to follow the instructions will result in equipment damage and operator injury. Failure to follow the instructions will lead to equipment damage.		Seat down key
	Please turn off the power supply when using		Backrest lean forward key
	Remarks: other important information, besides warning and attention		Backrest lean back key
	Type B equipment (Electric shock protection)		Chair Reset Key
	Refer to user manual		Memory Position Key
	Ground protection		Memory Position Key
	Alternating current		Memory Position Key
	off		Spittoon Rinse Position Key
	on		Air quick connection
	Water, Air, and Power Control Switch		Water quick connection
	Set key		Use Water Storage Bottle
	Rinse basin flush key		Use External Water Supply
	Mouthwash water key	<b>Bottle Air ON / OFF</b>	Water Bottle Air Switch
	Film Viewer		Debris Blower Knob
	Heating key		One-Touch Plumbing Disinfection
	Light key: on/off		Airflow Control key
	Adjust light intensity		Water Flow Control Key
	Stop blue light		Dental Control Key
	Infrared sensor		Water Adjustment Knob

## Things to note

- ▲ Warning: Power source must be reliably grounded.
- ▲ Warning: Disconnect power when cleaning or maintaining.
- ▲ Note: Avoid power disconnection during operation.
- ▲ Note: Only certified personnel may repair the device.

## Operational Instructions:

1. Ensure no objects are within the range of moving parts during operation.
2. Avoid using the device in areas with strong airflow, dust, or mist.
3. Do not make unnecessary adjustments to prevent wear.
4. Do not use a mobile phone near the device to avoid interference.
5. Ensure the needle is clean before insertion to prolong phone lifespan.
6. Do not open the cover or adjust internal parts during operation.
7. After a power outage, wait for stable power before restarting.
8. Keep the device away from water and humid environments.
9. Regularly clean and lubricate to extend equipment lifespan.
10. Avoid placing loads over 20kg to prevent deformation.
11. Keep hands away from moving parts during operation.
12. Ensure good ventilation; avoid confined spaces.
13. Only operate the device under normal conditions.
14. Do not use the device if it is in an abnormal state.
15. Avoid using the device in hazardous environments.
16. In emergencies, disconnect power or press the emergency stop.

## 1. Summary

### 1.1 Usage

Care series (top mounted and down mounted type) dental unit is suitable for modern dental hospital or clinic. It is used for diagnosing, treatment or operation. for tooth extraction; tooth scaling, tooth filling and implant.

This device can be divided into top mounted type (U) and down mounted type (D). This device is easier to use, needs less maintenance and has longer service life.

### 1.2 Composition

This device is composed of dental unit, dental chair and doctor stool. Dental unit is composed of high speed handpiece (optional), low speed handpiece (optional), oral lamp, film viewer, instrument tray, syringe gun, mouthwash water supply device, weak suction, strong suction, cuspidor, foot control pedal, water filter.

### 1.3 Classification

Class I Type B fixed device

### 1.4 The installer's duty

The installer should:

- Make sure the electricity voltage meet the manufacturer's demand;
- Make sure there is a switch to cut off power during installation for safety.
- Install and detect this device according to the operation manual.
- Provide the user with this operation manual.

### 1.5 The user's duty

The user should: Using this device according to this operation manual.

Maintain this device according to the time list made by the producer. The manufacturer or the dealer shall not assume any liability if any damage or injury is caused by the improper modification or maintenance conducted by the user that is not designated by us.

Please inform the sanitation department, the manufacturer or the dealer of the device immediately when accident is related with this device.

The report given by the manufacturer should include the model NO. And series NO.. The users could get these information from the technical label.

### ⚠ 1.6 Attentions

Only trained personnel may operate this device.

Danger: Ensure reliable grounding and use correct power (AC220V/50Hz). Disconnect power before cleaning or maintenance.

Avoid use in strong electromagnetic environments. Do not use near flammable anesthetic gases.

Keep hazardous items off the instrument tray.

Disconnect power and water/air supply if unused for long periods. Do not insert fingers into moving joints.

Consult the manufacturer before connecting other devices.

Connect only to a grounded power source to avoid electric shock. Do not modify without manufacturer authorization.

Ensure modifications are inspected for safety.

Keep the power plug accessible for easy disconnection.

### 1.7 Software

#### 1.7.1 Software Release Version: V1.0

#### 1.7.2 Operating Environment

Hardware Platform: Controller PCB hardware Microcontroller: ATMEGA168(8-bit)

RAM: 16KB

EEPROM: 1KB

## 2. Product introduction and features

### 2.1 Dental unit standard configuration

NO.	Configure	Quantity	Function Description	Remarks
1	Four-hole high speed turbine handpiece (optional)	Two sets	With blowing and anti-absorption functions	
2	Four-hole low speed motor handpiece (optional)	One sets	With straight and bend head tube	
3	Three-way syringe	Two sets		
4	Constant rinse water temperature system	One sets	Adjustable range 30°C - 45 °C	Care-22/Care-33 standard
5	Dental lamp	One sets		
6	Film viewer (optional for down mounted)	One sets		
7	Rotatable cuspidor	One sets		Care-11U/11D/22U/22D
8	Integral luxury cuspidor	One sets		Care-33U/33D
9	Rotatable side-box	One sets	Available for four hand operation	Care-11U/11D/22U/22D/33U/33D
10	Suction	One sets	time delay function	
11	Strong suction	One sets	time delay function	
12	Clean water system for handpiece	One sets	Clean water system for handpiece	
13	New design of foot switch	One sets	Fashionable and flexible	
14	New design of doctor chair	One handles	Ergonomic design backrest, beautiful and practical	

### 2.2 Dental unit standard configuration

1	With DC 24voltage motor, lower noise, easier to control and more reliable
2	Linkage compensation structure comply to the human engineering design
3	With safety protection function, make the users have more safe guards
4	With chair lock system
5	Digital computer program setting (three chair position user-defined memory)

### 2.3 Dental unit features

1	Linkage compensation structure comply to ergonomic design and make the patient more comfortable
2	prevention for leg/foot clamping. Safety protection setting ensure the safety of the doctors.
3	Chair will be locked while handpiece is working, ensure the safety of doctors
4	Integrated PU base with perfect combination of luxury and steady. (Care-22/Care-33 standard)
5	New luxury armrest
6	High-Speed Air Turbine Handpiece with Anti-retraction Function
7	High-Speed Air Turbine Handpiece with Debris Blowing Function

8	The strong and weak suction systems are equipped with separate filtration systems for easy disassembly and cleaning. At the same time, the system has a delay function to reduce dirt and odors in the suction pipeline
9	Care 11 apply sofa leather, Care 22 and Care 33 apply imported sewing leather
10	Film viewer (optional for down mounted)
11	Constant temperature water supply system & adjustable temperature option (standard for Care 22/33)
12	Built-in water storage system (standard for Care 22)
13	Water storage insufficiency alert system (Standard for Care 22)
14	Adopting a 90 degree rotatable ceramic bowl, it can be directly disassembled for cleaning and disinfection without using tools (standard for care 11)
15	Control LED oral light switch function can be added to the assistant console (optional, DCI-LED light needs to be installed)
16	Side box can be equipped with external water and air quick connectors (optional for Care 11)
17	One-Touch Water, Air, and Power Control Switch (optional)
18	Disinfection Function (optional)

## 3. Structure diagram

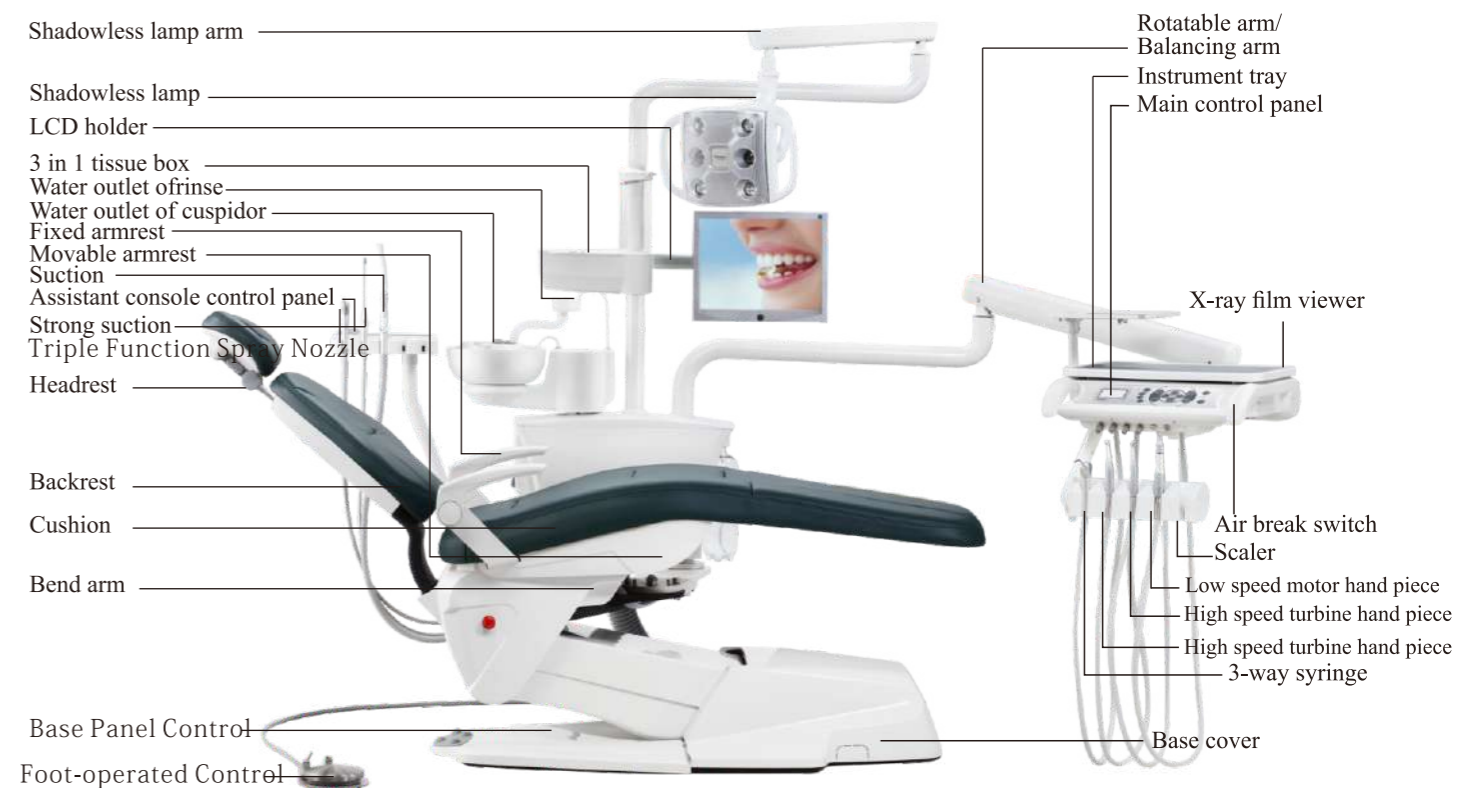

## 4. Environment requirements

Items	Environment requirements						
Preconditions	<ol style="list-style-type: none"> <li>1. Temperature: 5°C~ 40°C</li> <li>2. Relative humidity: ≤80%</li> <li>3. Pressure: 860Hpa~ 1060Hpa</li> </ol>						
Power supply	<ol style="list-style-type: none"> <li>1. The devices used in medical should conform to the installation rules. All the water and electricity installation should be accorded with national regulations</li> <li>2. The power used: AC230 50Hz/60Hz</li> </ol>						
Water supply	<ol style="list-style-type: none"> <li>1. conformance to local drinking water regulations.</li> <li>2. Cleaning all the pipes before using</li> <li>3. Pressure: 0.2 MPa~ 0.4 MPa</li> <li>4. Water flowing rate: no less than 10L/min</li> <li>5. The water hardness limit is less than 2.14mmol/L</li> <li>6. PH valve :6.8-8.5</li> <li>7. Maximum particle diameter less than 100 microns</li> </ol>						
Air supply	<ol style="list-style-type: none"> <li>1. Clean, dry and no oil</li> <li>2. Pressure: 0.55MPa ~0.7 MPa</li> <li>3. Air flowing rate: no less than 50 L/min</li> <li>4. use the air source supply which has related exhausting pressure as 0.8MPa.</li> </ol>						
Waste water pipe	The wastewater piping should slope 1 cm per meter, with a flow rate of at least 4 L/min						
Transportation & Storage	<p>Transport requirements must follow the order contract. During transport, avoid severe collisions and exposure to rain or snow. The packaged equipment should be stored indoors with a relative humidity below 85%, no corrosive gases, and good ventilation. Ambient temperature range: -20°C to +55°C</p> <p>Relative humidity: ≤85%</p> <p>Atmospheric pressure range: 700 hPa to 1060 hPa</p> <p>Avoid direct sunlight during storage.</p> <p>Dispose of waste, residues, and equipment beyond its useful life according to local laws and regulations.</p>						
Head loss	<table border="0"> <tr> <td>90 NL/min: 24.21mbar</td> <td>200 NL/min: 89.84mbar</td> <td>350 NL/min: 182.34mbar</td> </tr> <tr> <td>150 NL/min: 50.38mbar</td> <td>300 NL/min: 140.58mbar</td> <td>400 NL/min: 223.22mbar</td> </tr> </table>	90 NL/min: 24.21mbar	200 NL/min: 89.84mbar	350 NL/min: 182.34mbar	150 NL/min: 50.38mbar	300 NL/min: 140.58mbar	400 NL/min: 223.22mbar
90 NL/min: 24.21mbar	200 NL/min: 89.84mbar	350 NL/min: 182.34mbar					
150 NL/min: 50.38mbar	300 NL/min: 140.58mbar	400 NL/min: 223.22mbar					

## 5. Technical parameters

Items	Technical parameters	
Power supply	AC 230V 50HZ/60HZ	
Power	600VA	
Fuse	∅6X20 T2AL、T3AH、	
High Speed Turbine hand piece	Unload speed: ≥300000r/min Working pressure: 0.26MPa	
Low Speed hand piece	Unload speed: ≥10x10 <sup>3</sup> r/min~40x10 <sup>3</sup> r/min	
Foot switch	IPX 1	
Lamp luminance	DCI LED LEVEL 1:4000-6500Lux DCI LED LEVEL 2:11625-12400Lux DCI LED LEVEL 3:16750-18000Lux DCI LED LEVEL 4:21875-23600Lux DCI LED LEVEL 5:27000-30000Lux	
Lamp bulb	Halogen lamp 12V-50W DCI LED 24V-0.25A	
Film-viewer luminance	≥2000 Lx	
Rinse water thermostat	24V-80W Temperature range 35-45 ° C	
Linear motor	24V = 100W	
Instrument tray load	1KG	
Dental chair max load	180KG	
Maximum height from ground	Care 11/22 800mm Care 33 830mm	
Minimum height from ground	Care 11/22 390mm Care 33 390mm	
Elevation and depression angel of backrest	0° - 80°	
Cycle Time	One minute for working and 15minutes for rest	
Pipeline color identification	Water lines: Clear black, clear blue Air lines: Orange, black, yellow, clear	
Equipment weight	Net weight: 225 KG Gross weight: 336 KG	
Package(2 boxes)	Dental chair	Length:1450mm Width:900mm Height:935mm
	Dental unit	Length:1448mm Width:868mm Height:1275mm
1 Box	Dental unit(short)	Length:1608mm Width:1128mm Height:1295mm

## 6. Plane layout drawing

1. water supply pipe: white PPR hot melt pipe, reserve 4cent copper internal teeth interface. (PPR hot melt pipe, 4 cent inner outer teeth straight through valve is recommended)
  2. air supply pipe: the same as water supply pipe.
  3. waste water pipe: white PVC drain pipe, main pipe  $\Phi 75\text{mm}$ , branch pipe  $\Phi 50\text{mm}$
  4. VGA monitor and USB data wire pipe: white PVC threading pipe  $\Phi 32\text{mm}$ , reserve one iron wire for threading.
  5. negative pressure pipe: blue UPVC water supply pipe, main pipe outer diameter 50mm, branch pipe outer diameter 32mm, pipe connect to the chair diameter 25mm
  6. negative pressure signal wire: white PVC pipe, 4cent( $\Phi 20\text{mm}$ ) pipe sleeve 3\*1mm 2 wire.
  7. power cord: white PVC pipe, 4cent( $\Phi 20\text{mm}$ ) pipe sleeve 3\*1mm, 5mm 2 wire.
- Notes: do not use right angle connector between drain pipe and negative pressure pump, 45-degree connector is recommended.

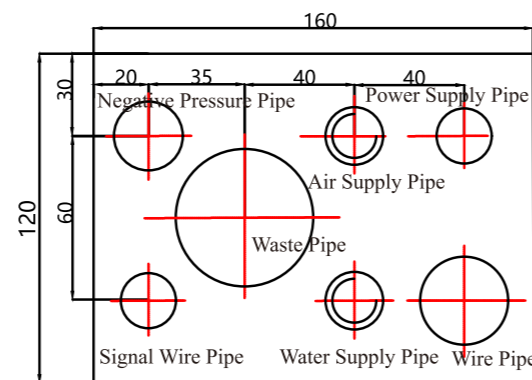
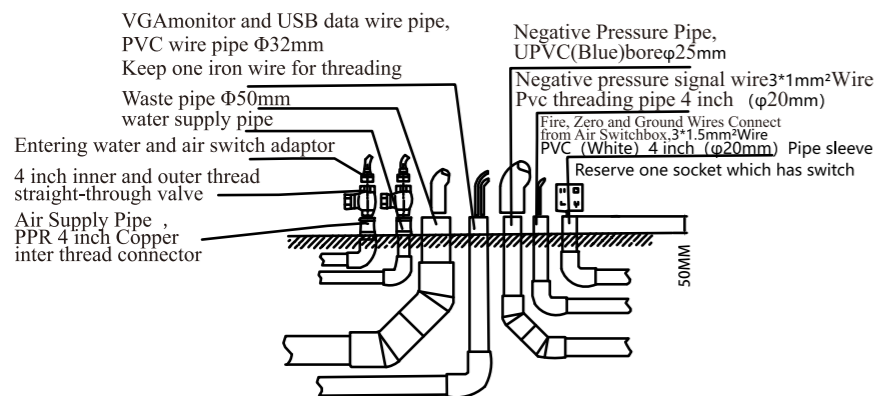
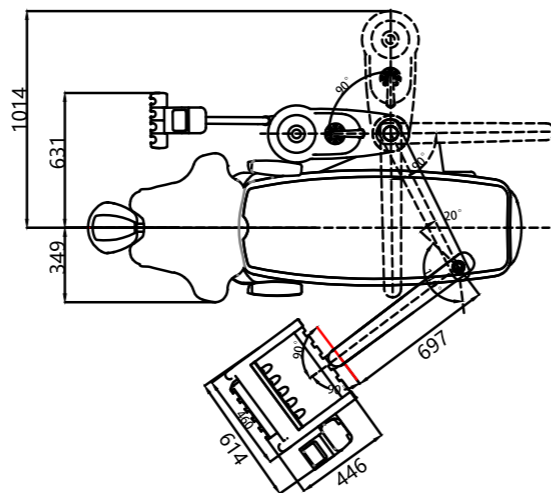
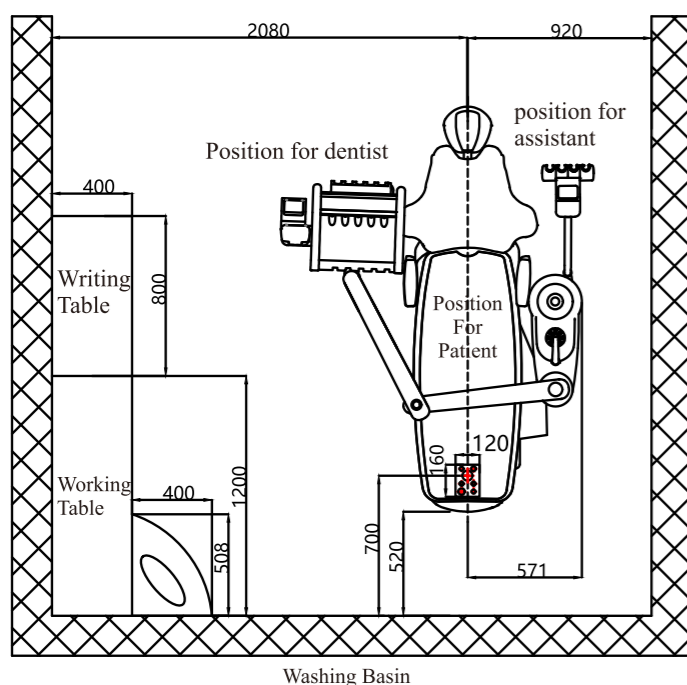

## 7. Installation

### 7.1 Preparations

- 1> Confirm the installation position according to the actual situations layout of clinic, light and operation convenience of the clinic, and ensure the device can work on the clean, dry and ventilated place.
- 2> Ensure the floor hold the device is solid and level, reserve enough space for operation
- 3> The socket of power supply is triangle socket with ground wire.
- 4> Open the packing box of the treatment machine, take out spare parts.
- 5> Check accompanying documents: instructions, qualification card, guarantee card and packing list.
- 6> Check if the equipment is intact and accessories are complete.
- 7> Arrange the water inlet pipe, air inlet pipe, water outlet pipe and power cord within the range of the base box according to the structure drawing below.
- 8>Standards and requirements of the water inlet pipe, air inlet pipe, water outlet pipe and power cord: .

Item	Standards	Height above the ground	
Inlet pipe for water	$\Phi 15\text{mm}(1/2")$	20mm	$3/2"$ Pipe threads; safety valve switch should be installed in the connector
Inlet pipe for air	$\Phi 15\text{mm}(1/2")$	20mm	$3/2"$ Pipe threads; safety valve switch should be installed in the connector
water outlet pipe	$\Phi 40\text{mm}(1 1/2")$	20mm	
Line cord	$2\text{mm}^2$	50mm	

### 7.2 Dental unit installation

- 1> Open the packing box of the dental unit, take out spare parts.
- 2> Check enclosed documents: Instructions, quality certificate, guarantee card and packing list.
- 3> Dental unit installation procedures as below:
  1. Use the NO. 14 tool to unload the fixed screws on pallet (as picture 1 shows). Then connect the power, switch on the power, lift the dental chair and open the base box cover.
  2. Use the hex key with number 6 to remove the two M8 screws inside the dental chair as illustrated in Figure 2.
  3. Move the dental unit to the appointed position  
(Attention! Please carry the base of the dental unit. Do not carry the backrest or seating cushion)

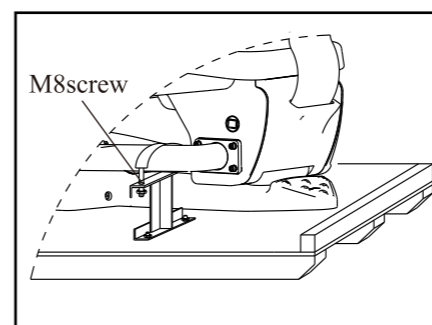

Fig-1

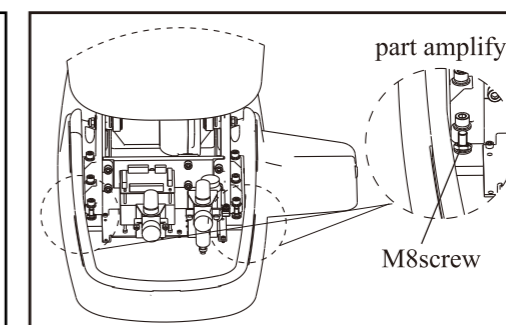
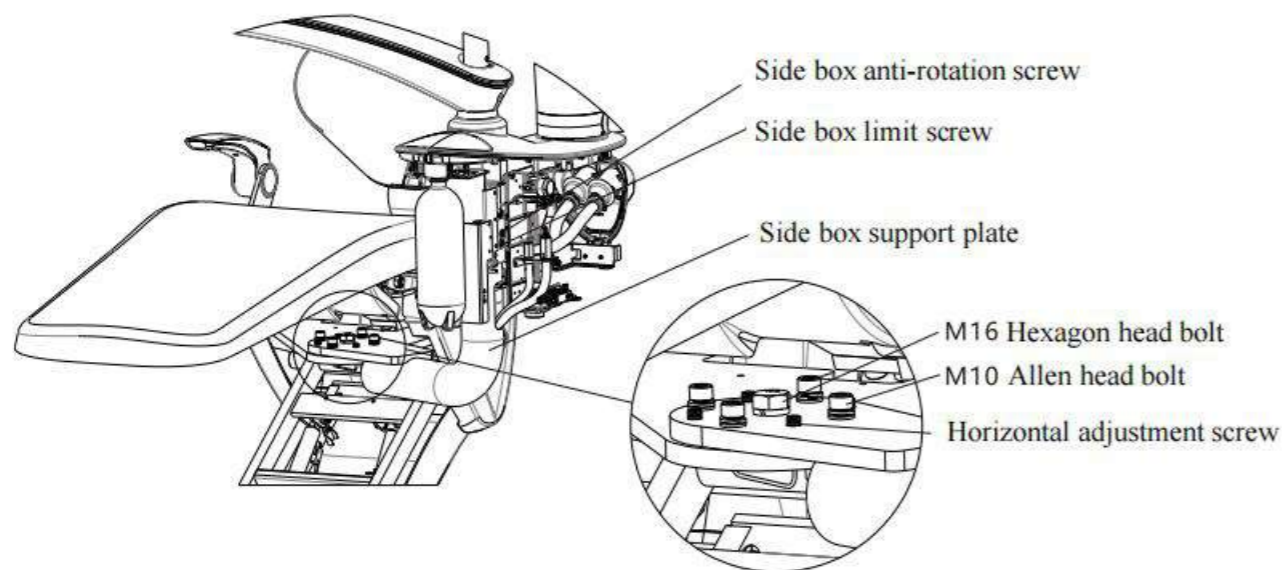

Fig-2

### 6.2.4 Equipment Handling

- (1) For treatment machines with front-side box tray fixation, if the clinic door width is 80cm, the machine can be moved into the room by rotating the side box and tray. Steps:
- (1.1) Remove the PU seat cushion.
  - (1.2) Remove the M10 hexagon screw and loosen the M16 hexagon screw to narrow the overall width by rotating the side box and tray. (It can pass through a door with a minimum width of 80cm).
  - (1.3) After entering the room, place the machine in the designated position, then reverse the steps: tighten the M10 and M16 screws, and reinstall the side box limit screw.



- (2) For treatment machines with rear-side box tray fixation, narrow door entry requires removing the side box tray. Position the side box tray at the pinhole, then secure it with the provided M10 hexagon screw and spring washer.

Note: This process requires multiple people to assist.

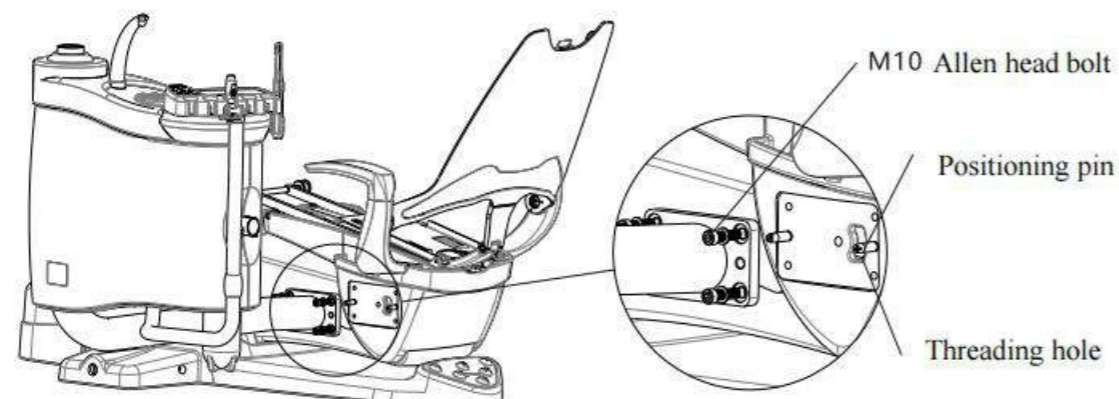

### 7. Split-Type Treatment Machine Disassembly and Assembly Steps:

- 7.1 Power on the dental chair, raise it, open the floor box cover, and use a 6mm hex wrench to remove the screws connecting the chair frame to the wooden base.
- 7.2 Remove the side box from the mounting plate.
- 7.3 Transport the treatment machine to the designated clinic position.
- 7.4 Position the side box tray at the dental chair's connection point, align connectors, and secure the M10 X45 hex screws with an 8mm hex wrench. Multiple personnel are required; check level alignment after securing.

1. Transport only from the base; do not lift by the backrest or seat edges.
2. Assistance from multiple personnel is required during disassembly.
3. Ensure screws are securely tightened during assembly.

- 7.5 For equipment with internal chair wiring, refer to the illustration. (Note: Side box appearance may vary; fixation and connection methods remain the same.)

- 7.5.1 Position the side box at location "A" as shown in the diagram, then initially secure it using M6 external hexagon screws. Adjust the side box to the correct alignment.

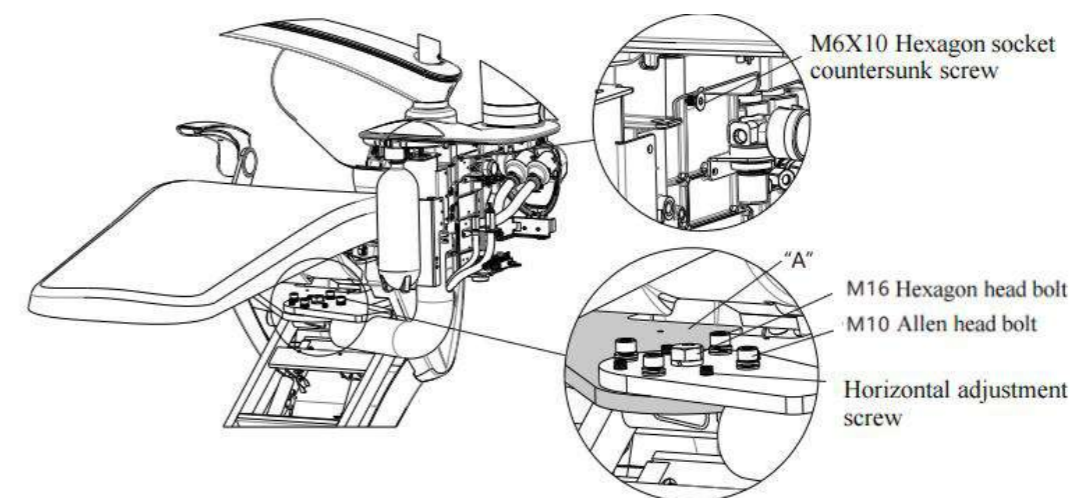

- 7.5.2 Insert the balance arm and instrument tray assembly into the side box column. Secure the swivel arm connection column to the side box column with M6 internal hexagon countersunk screws. Note: For easier cable routing through the side box column, temporarily secure water, air, and power cables with tape.

- 7.5.3 Connect the water and air pipes by matching the corresponding colors.

Note: Attach a retaining ring at the connection point

- 7.5.4 Cable Management: Arrange the water, air pipes, and electrical wires as shown in the diagram.

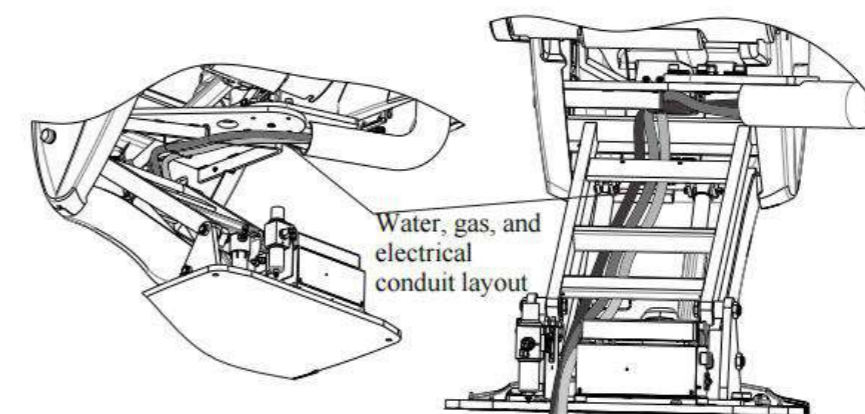

7.6> For equipment with rear-side box tray fixation, refer to the diagram.

(Note: The appearance of the side box may vary, but the fixation and connection methods remain the same.)

7.6.1> Remove the side box from the bracket.

7.6.2> Connect the side box tray to the chair frame.

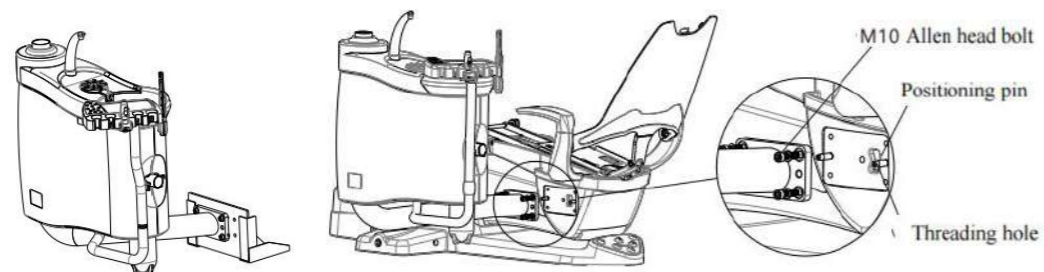

## 8. Model 33 Chair Frame Assembly

### 8.1 Backrest Installation

1. Use a 3mm hex wrench to loosen the set screw securing the cylindrical pin, then remove the pin.
2. Adjust the backrest to the correct position, aligning the holes at the bottom of the backrest with the holes in the backrest connector.
3. Using a rubber hammer, insert the stainless steel cylindrical pin into the holes.
4. Tighten the set screw on the backrest with a 3mm hex wrench.

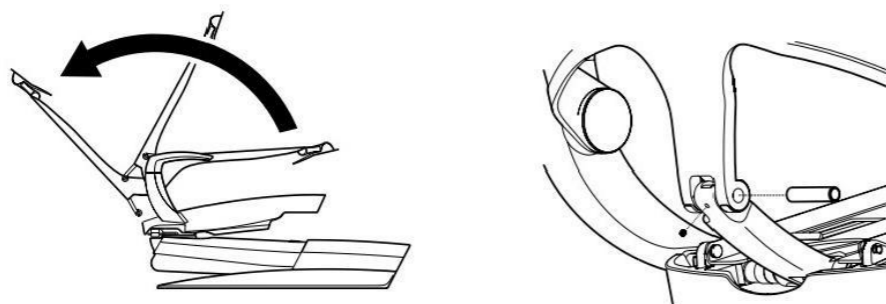

### 8.2 PU Seat Cushion Installation

1. Rotate the two buckles to the horizontal position.
2. Place the PU seat cushion on the seat support plate, aligning and sliding it into the square slots.
3. Ensure the two rectangular metal pieces are in the correct position, then rotate the buckles 90 degrees to secure.

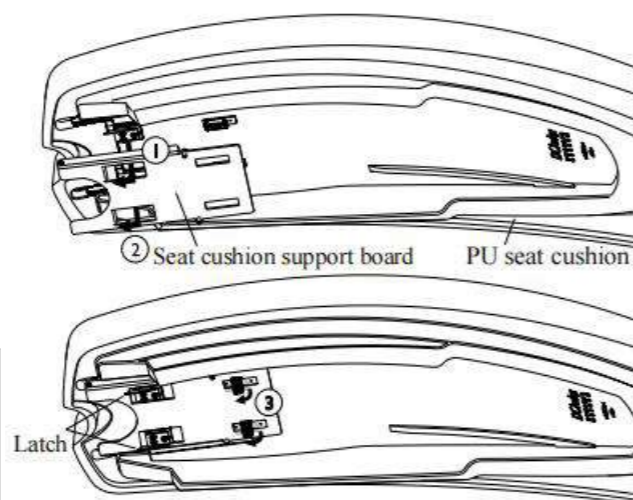

Warning: Incorrect installation of the PU seat cushion may damage the machine or even cause personal injury.

### 8.3 PU Backrest Installation

Position the backrest at a 45° angle.

1. Align the lower locking slot of the backrest frame with the flat-head screws on the metal backrest, then install the PU backrest.
2. Press the PU backrest down and push it towards the seat until the flat-head screws slide into the grooves.
3. Ensure all four screws are fully engaged, then push the backrest into place until it clicks, securing the locking screws in the PU backrest.

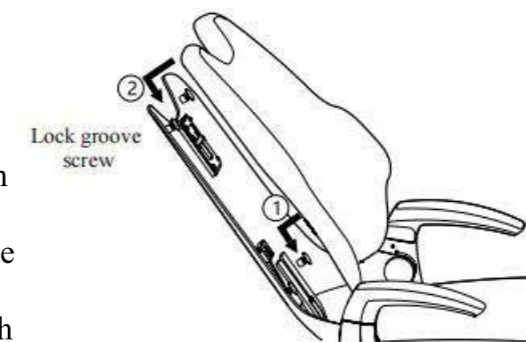

### 8.4 PU Headrest Installation

1. Align the locking slot in the PU headrest with the flat-head bolt in the headrest assembly.
2. Press the headrest down and push it towards the backrest until the screw slides into the groove.
3. Secure the headrest cover and PU headrest using #6-32 screws.

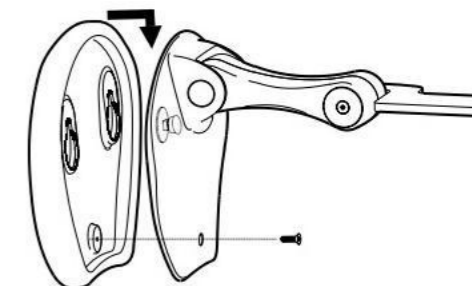

## 9. Installation of the output assistant bracket on the side box of model 55

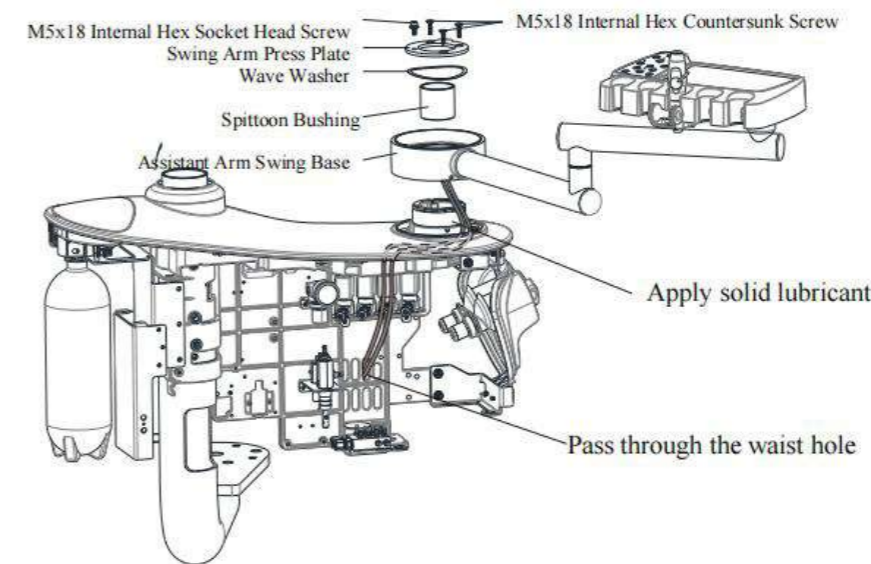

1. Thread the two wires through the side box cover and connect them to the rear circuit board as shown.

2. Install the "assistant bracket rotating arm base" onto the side box aluminum frame, place the "wave washer," and secure the "rotating arm pressing plate" with screws.

Attention: After threading the wires through the cover, ensure they have a certain curvature and make sure the wires do not become taut or twisted when rotating the assistant arm.

10. Installation of the 55-type side box sputum cup assembly

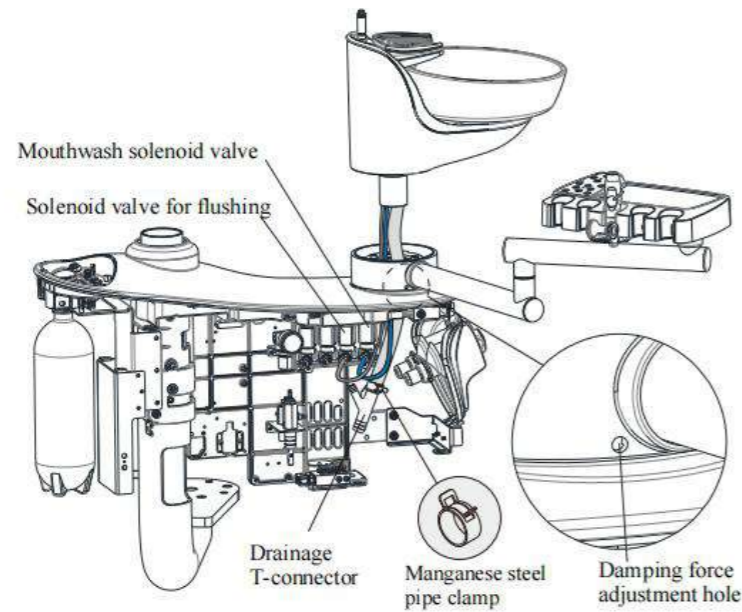

1. Connect the transparent black tube (flushing tube) to the flushing solenoid valve, and the transparent blue tube (mouthwash tube) to the mouthwash solenoid valve.  
Note: Tighten the nuts with a wrench to prevent leakage.
2. Connect the steel wire tube to the lower "watertee" and secure it with the "manganese steel pipe clamp."
3. Rotate the hole at the assistant arm base to the vertical position, as shown, and use a 2.5mm Allen wrench to adjust the sputum cup's rotation tightness.

11. Circuit board interface connection instructions

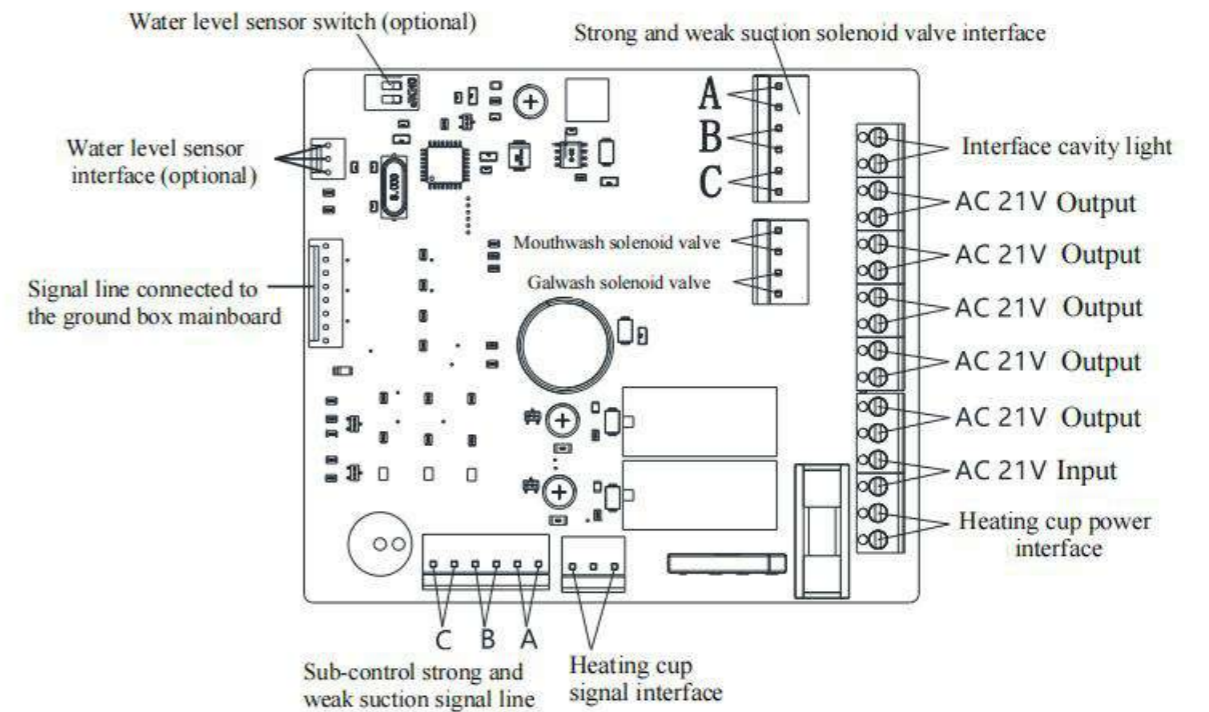
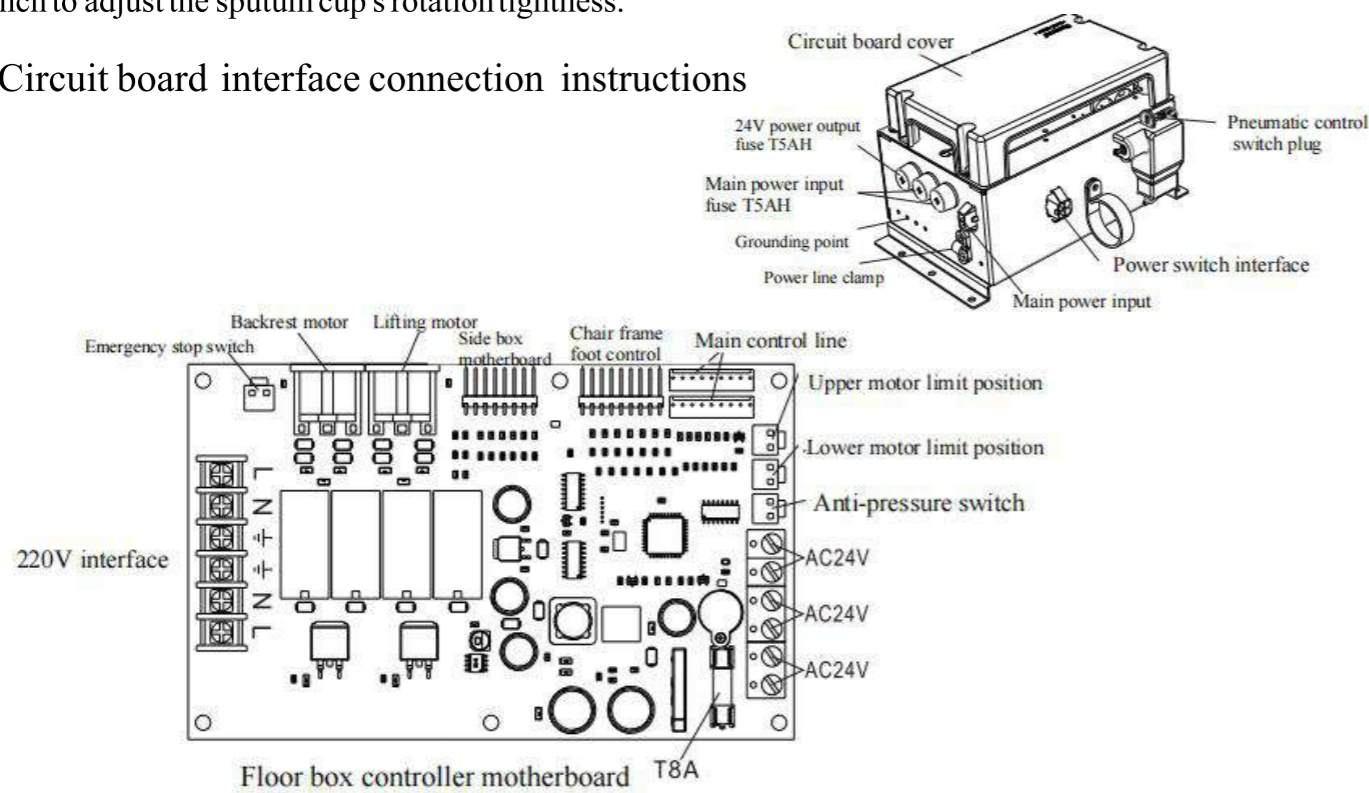

Side box mainboard - without temperature control

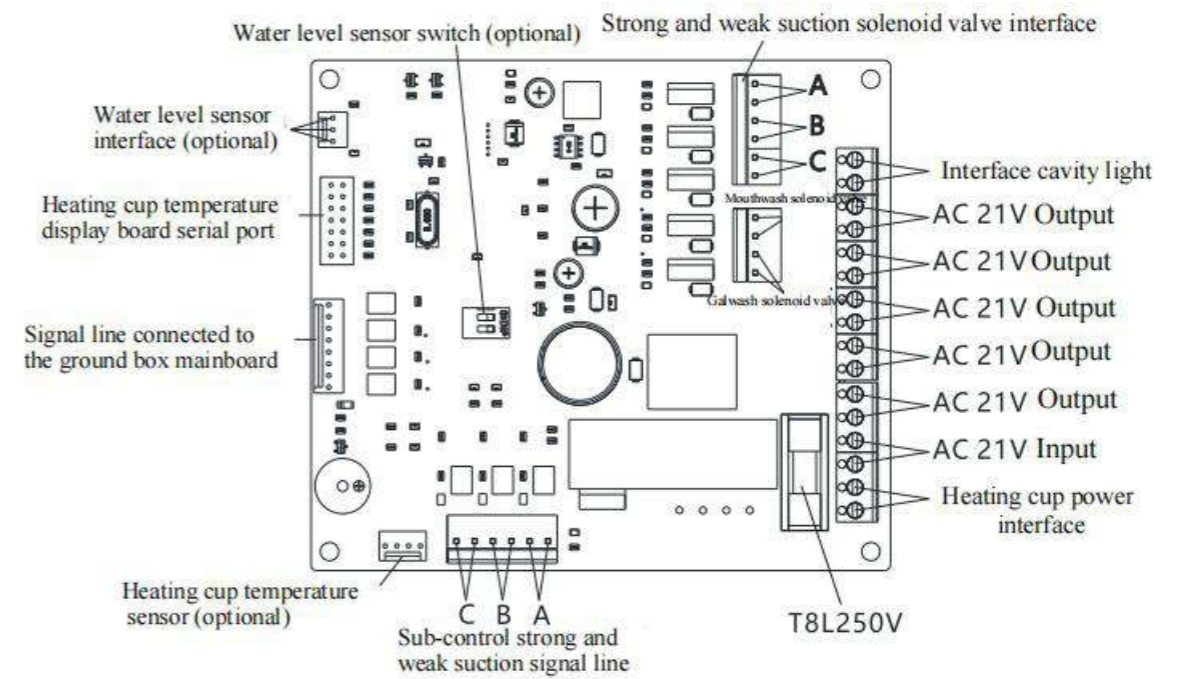

Side box mainboard - with temperature control

## 12. Installation of the light column - light arm - oral light components

12.1>Remove the light arm assembly and thread the wires through the light column as shown in the diagram.

12.2>Connect the connector to the connector located inside the side column of the treatment machine.

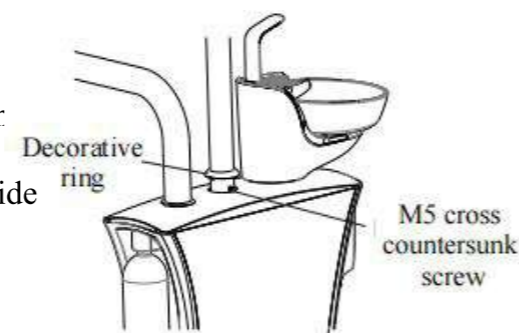
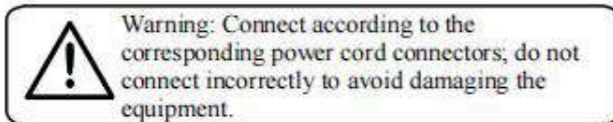

Note: Do not forget to install the decorative ring during assembly.

12.3>Connect the oral light wires to the light arm, insert the light shaft into the right joint hole, and secure the light head with an M5 screw.

12.4>Secure the light column with an M5 screw.

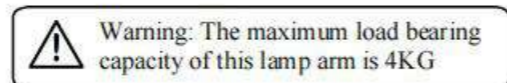
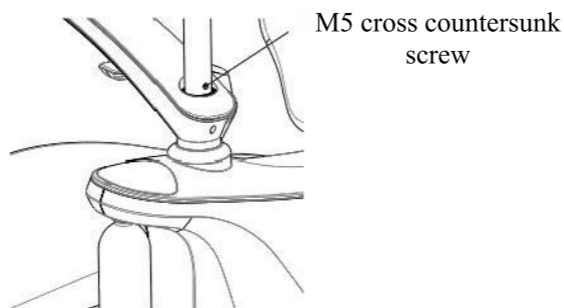
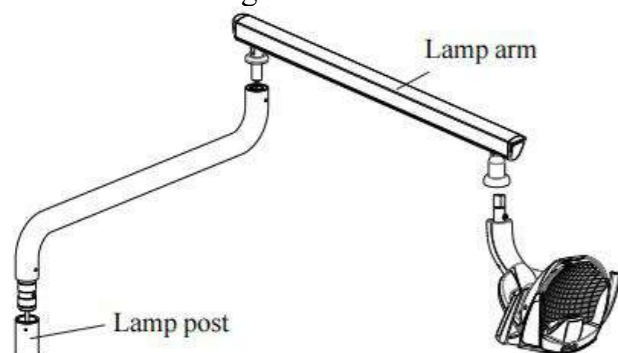

## 13. Ground box piping installation

1>Before connecting the pipes, drain the water and air inlet pipes to remove impurities and ensure smooth operation.

2>Connect the supplied check valve to the water and air inlet pipes.

3>Connect the 48X5PU tube from the accessories to the water source (blue tube) and air source (black tube), ensuring a proper seal.

⚠ If the treatment machine's air and water inlet pipes do not have separate switches, connect the 2 supplied 1/4 ball valves to the air and water pipes for easier maintenance. The dual water system includes 3 1/4 ball valves (for separate tap water and disinfectant water).

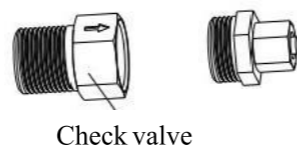

4>Insert the treatment machine's drainage pipe into the pre-installed drainage connection. After connecting the drainage and exhaust pipes, ensure they are unobstructed.

Note: During installation, ensure the air inlet pipe and water inlet pipe are correctly identified by color.

## 14. Power supply installation

1>Plug the treatment machine's power cord into a grounded power outlet.

2>Turn on the main power switch on the side of the dental chair to use. Turn off the power switch after use.

⚠ Note: In case of emergency, press the emergency stop switch.

## 15. Dental chair

15.1>Model 11/22 chair frame

1>The dental chair uses a 24V linear drive motor for low noise.

2>The limit position dimensions of the dental chair are shown in the diagram.

3>The headrest can be adjusted forward, backward, and flipped.

4>The armrests can be rotated up or down by turning the armrest button.

Note: The maximum load for the armrest is 20kg.

5>The rear of the dental chair has buttons to control the chair position and backrest adjustment.

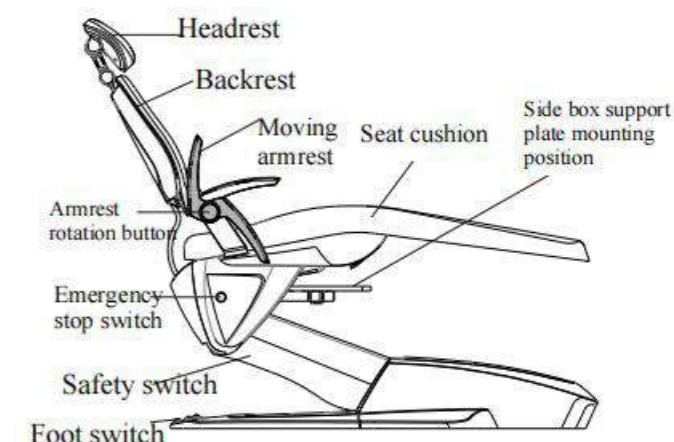

### Dual-joint structure

Support the rear of the headrest with one hand, then press the locking button on the right to adjust the position. Once pressed, the dual-joint mechanism is unlocked, allowing free movement for adjustment.

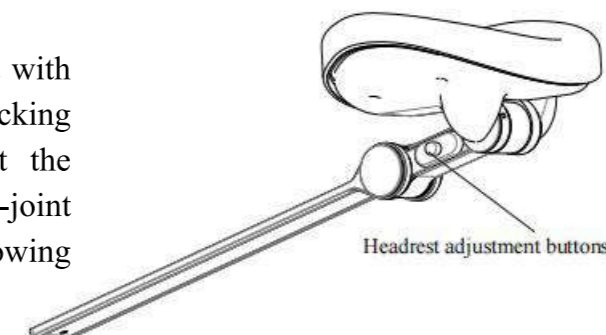

Warning: Do not move beyond this line.

### Headrest connecting rod

#### Position adjustment

Adjust the headrest height to suit the patient. The locking mechanism on the headrest bracket allows the headrest to be fixed at any position. When the patient is lying on the chair, the headrest must not move beyond the marked black line.

Warning: Moving the headrest beyond the marked line may cause injury to the patient or doctor.

### Safety brake

When the chair moves down, it will stop if the support rod casing hits an obstacle. The safety switch, located at the bottom of the casing, can be triggered from either side. Once activated, the chair will move upward slightly for safety instead of continuing downward.

### Emergency stop switch

Pressing the emergency stop switch cuts power to the chair's mainboard, halting upward or downward movement. Turning the knob will release the switch, restoring power.

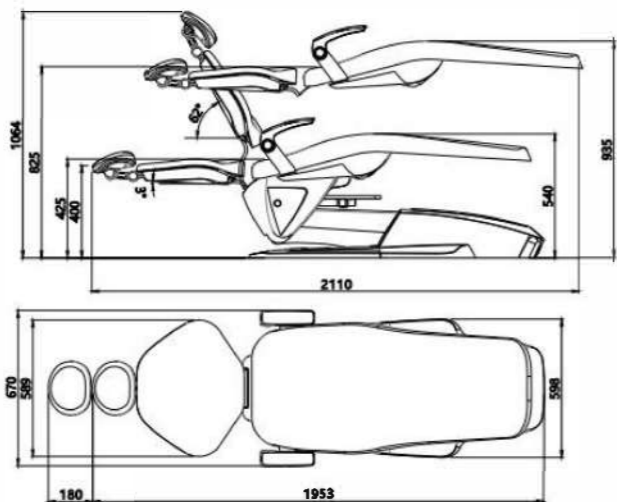

Note: Measurements differ at the highest and lowest points.

15.2>Model 33 chair frame

- 1>The dental chair uses a 24V linear drive motor with low noise.
- 2>The chair's limit position dimensions are shown in the diagram.
- 3>The headrest is adjustable in both forward-backward and tilt directions.
- 4>The right armrest is rotatable.
- Note: The maximum load for the armrest is 20kg.
- 5>There are buttons on the rear of the chair to control the seat and backrest movement.

15.2.1>Headrest

Dual-joint structure

Support the rear of the headrest with one hand and press the right-side locking button. This unlocks the dual-joint mechanism, allowing free adjustment in height and angle.

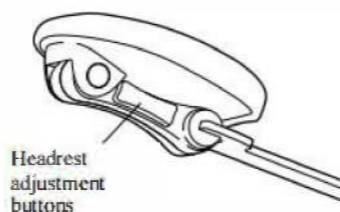

Headrest adjustment buttons

Warning:

Do not move beyond this line.

Headrest connecting rod

Position adjustment

Adjust the headrest to the patient's suitable height. The locking mechanism secures the headrest at any position. Do not move the headrest past the marked black line.

Warning: Moving the headrest beyond the marked line may cause injury to the patient or doctor.

Tightness adjustment

Adjust headrest height by moving the bracket. Use a 4/64" hex wrench to tighten or loosen the locking screw at the backrest top to adjust tightness.

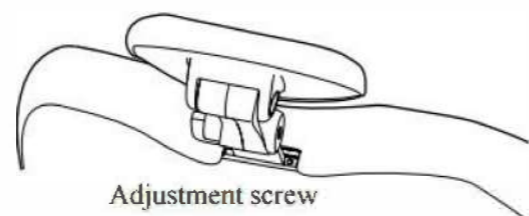

Adjustment screw

Safety brake

When the chair moves down, it stops if the support rod casing hits an obstacle. The safety switch, located at the bottom of the casing, can be triggered from either side. Once activated, the chair will move upward slightly for safety instead of continuing downward.

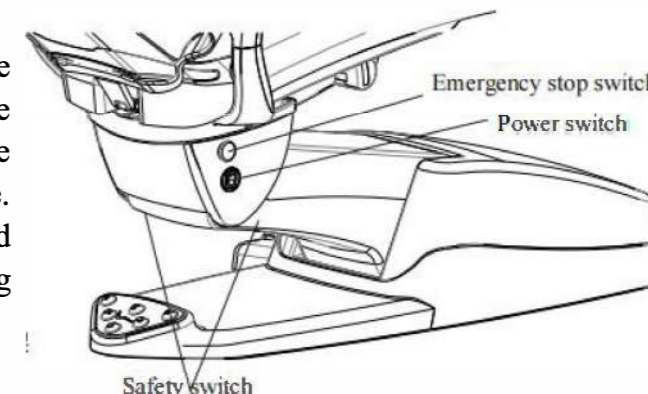

Emergency stop switch

Pressing the emergency stop switch cuts power to the chair's mainboard, halting movement. Rotating the knob releases the switch, restoring power.

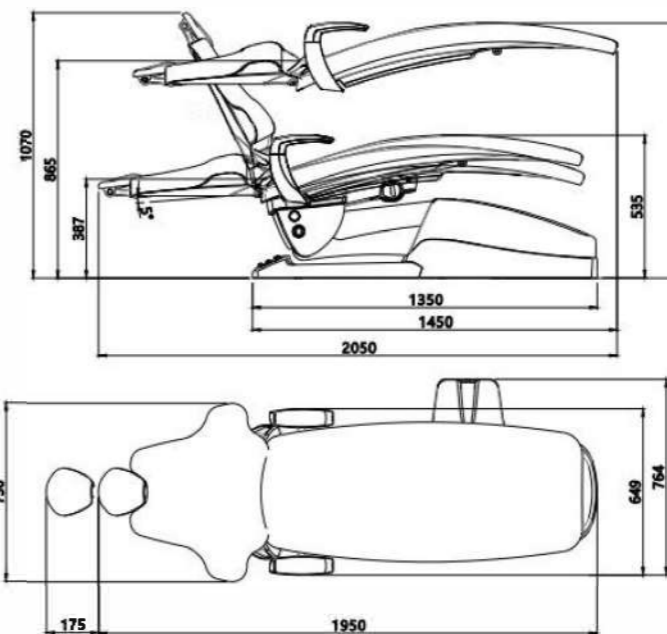

Note: Measurements vary at the highest and lowest points.

16.Sidebox component

16.1 Sidebox main body

The sidebox can rotate 0~90°, enabling ease of use for various treatments and four-handed operations.

16.2 Ceramic basin, mouthwash, and rinse water

- 1>The ceramic basin for models 11/22/55 can rotate 0~90°, while the model 33 basin is fixed.
- 2>Users can adjust the rinse and mouthwash water flow by tightening or loosening the valve. Tightening reduces the flow, while loosening increases it.
- Note: Do not loosen the knob too much to avoid damaging the valve.

16.3 Water temperature display (standard on 22/33/55 side boxes)

- 1>This button displays the current water temperature in the heater.
- 2>After pressing the mouthwash heater button, the heating temperature can be set between 35°C and 45°C according to user needs.

Note: Before first use, ensure water is connected to the heater to prevent dry heating.

**Model 11 Side Box Instructions**

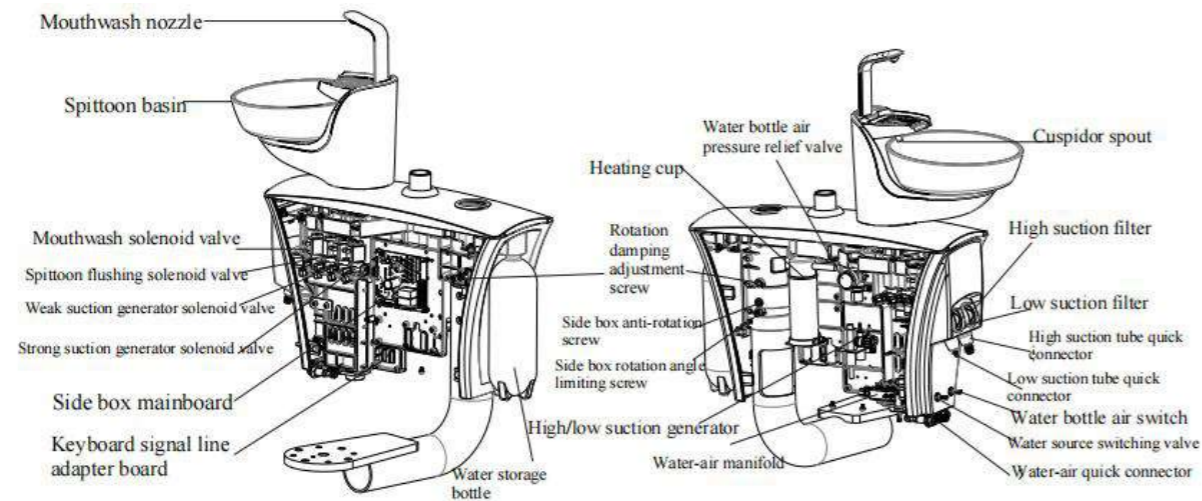

**Model 55 Side Box Instructions**

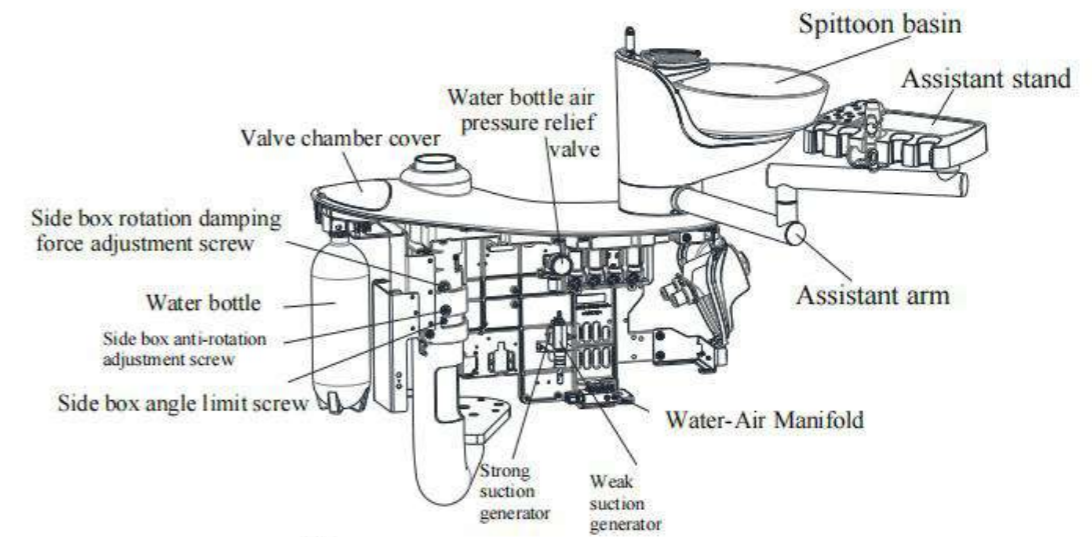

**Model 22 Side Box Instructions**

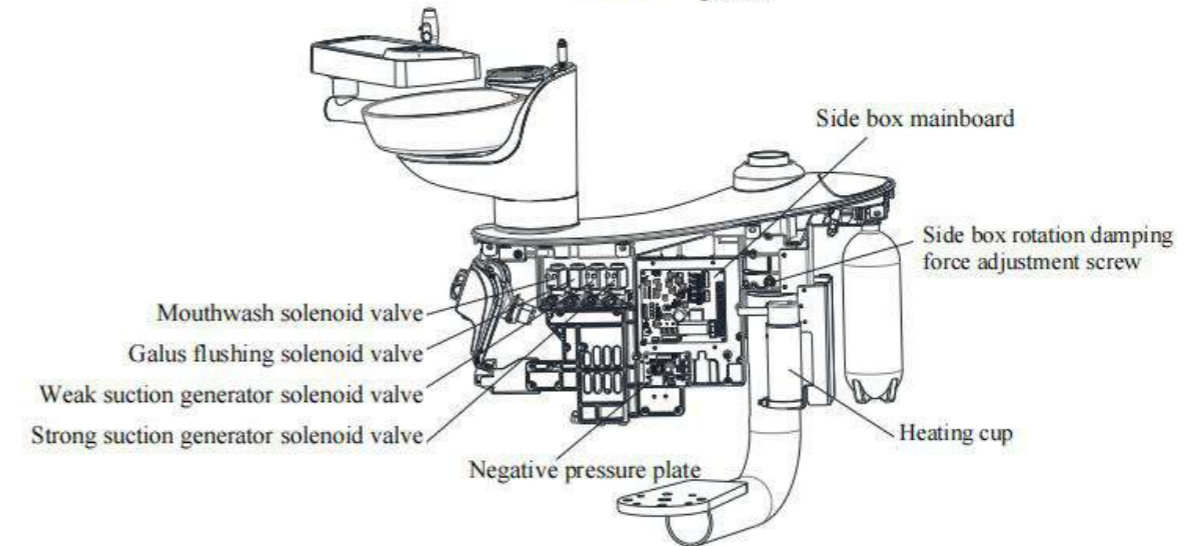

**Model 33 Side Box Instructions**

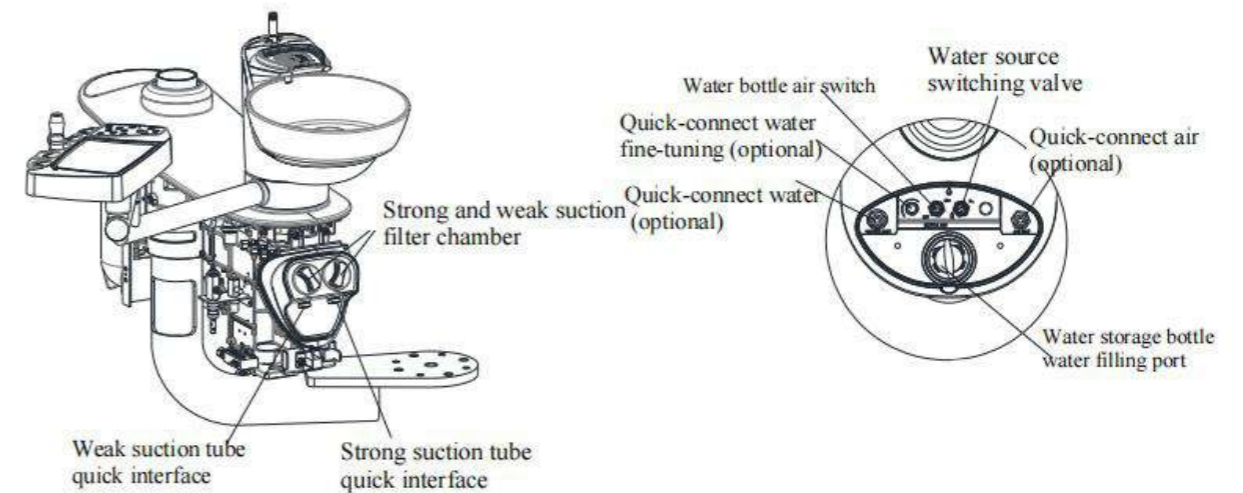
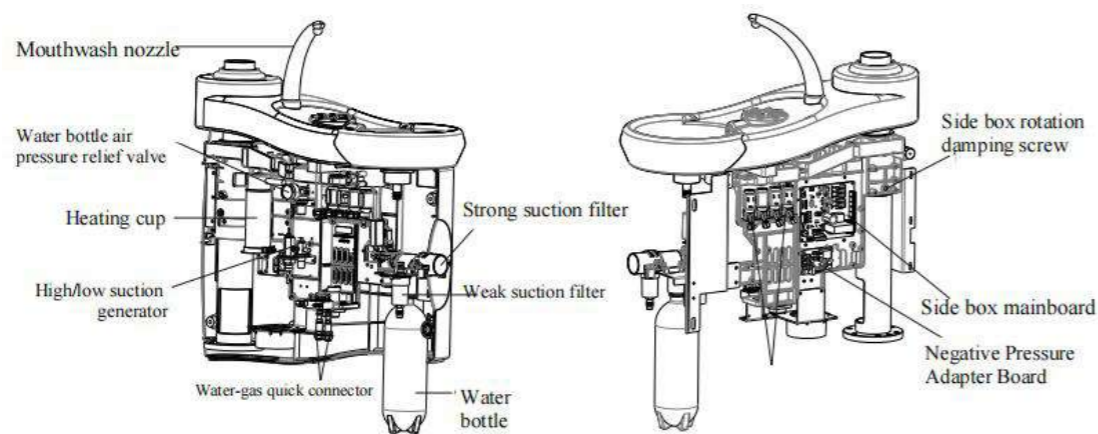

## 16.4 Water bottle

This device has two water supply options for the instrument tray: the water bottle system and the external water supply system.

- 1>The water bottle stores purified water for use with high-speed turbines, low-speed handpieces, three-way syringes, and ultrasonic scalers.
- 2>The water bottle capacity is 1000ml per refill.
- 3>It is recommended to use purified water or medical-grade distilled water.
- 4> For the 22 model sidebox, the water bottle filling process is as follows:
  - 4.1 Turn off the water bottle air switch at the bottom of the sidebox.
  - 4.2 Once no venting sound is heard from the water bottle, unscrew the bottle cap.
  - 4.3 Use a filling funnel to add water, then tighten the cap.
  - 4.4 Turn on the water bottle air switch.
- 5>For models 11/33/55 sidebox, the water bottle filling process is as follows:
  - 5.1 Turn off the air switch for the water bottle at the bottom of the sidebox.
  - 5.2 After the venting sound stops, unscrew the water bottle.
  - 5.3 Add purified water or medical-grade distilled water, then screw the bottle back on tightly to prevent air leakage.
  - 5.4 Turn on the air switch for the water bottle.
- 6>The sidebox has a water source switch to select between the water bottle or external water supply for the instrument tray. (Location varies by model; see sidebox component description.)



Warning: Use purified or medical-grade distilled water from the water bottle as the primary water source for the instrument tray to protect waterlines and extend the lifespan of treatment equipment(e.g., high-speed turbines, low-speed handpieces, three-way syringes, ultrasonic scalers).

## 17. Assistant bracket

### 17.1 Three-way syringe

- 1>The three-way syringe on the assistant bracket is connected to the mouthwash heater. When the heater is on, it supplies water at a constant temperature.
- 2>For other operations, refer to "Three-way Syringe Setup."

### 17.2 Saliva ejector

- 1>The saliva ejector removes fluid from the oral cavity during surgery, using water and air suction for negative pressure.
- 2>The ejector activates when the suction tip is lifted.
- 3>After use, the ejector runs for 5 seconds (delay setting) before turning off automatically.
- 4>With water pressure $\geq 300$ Kpa, vacuum $\geq 13$ Kpa, and suction rate $\geq 0.42$ L/min.
- 5>Suction tube and connector length: 6mm.
- 6>Filter mesh (1mm pore size) should be cleaned and disinfected daily.

### 17.3 High-power suction

- 1>Used during surgery to suction water, saliva, and small particles from the oral cavity.
- 2>Powered by air source to generate negative pressure.

3>After use, the suction runs for 5 seconds to clear remaining debris in the tube. (Note: Clean the filter regularly.)

4>With air pressure  $\geq 300$ Kpa, vacuum  $\geq 13$ Kpa, and suction rate  $\geq 1.2$ L/min.

5>Suction tube and connector length: 10.5mm.

6>Filter mesh (1mm pore size) should be cleaned and disinfected daily.

## 18. Instrument tray

### 18.1 Instrument tray holder

- 1>Used to place medicines and instruments needed during treatment.
- 2>Supports items weighing up to 2kg.

### 18.2 Drive air pressure gauge

- 1>Displays air pressure for high-speed and low-speed handpieces.
- 2>High-speed turbine pressure: 0.22~0.25MPa, adjustable via the valve below the tray.
- 3>Low-speed handpiece pressure: 0.3~0.32MPa, adjustable via the valve below the tray.

### 18.3 Air brake left (right) switch

- 1>Controls the elevation of the balance arm.
- 2>Press the air brake left (right) switch to adjust the balance arm (instrument tray) to the desired height, then release the switch.

### 18.4 Drive air control valve

- 1>Regulates the air intake pressure for high-speed turbines and low-speed dental handpieces.
- 2>Rotate the adjustment knob clockwise to decrease pressure, counterclockwise to increase pressure. Adjust slowly while monitoring the pressure gauge.

### 18.5 Water flow control valve

- 1>Regulates the water flow for high-speed turbines and low-speed dental handpieces.
- 2>Rotate the knob clockwise to decrease flow, counterclockwise to increase flow. Adjust slowly while monitoring the water output.

### 18.6 X-ray viewer (optional)

- 1>Used for viewing dental X-rays.
- 2>Flip the X-ray viewer up to turn it on, and close it down to turn it off.

### 18.7 Three-way syringe

- 1>Used for rinsing and drying the treatment area.
- 2>For operation, refer to "Three-way Syringe Setup."

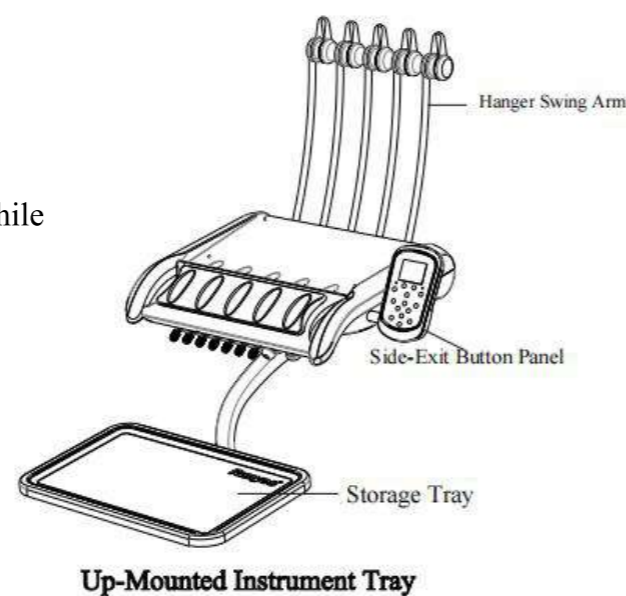
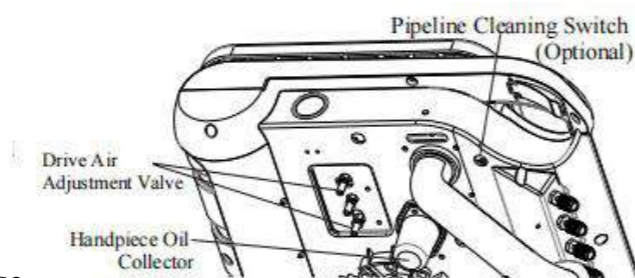
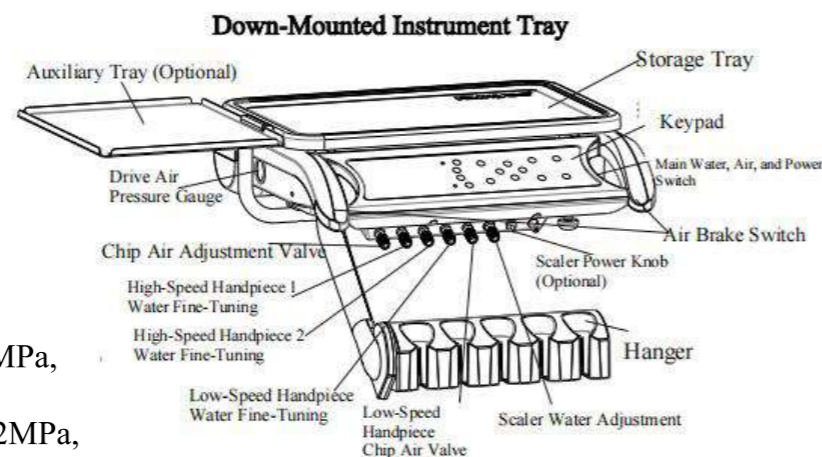

### 18.8 High-speed turbine handpiece

- 1>Used for treatment and surgery.
- 2>For operation, refer to "High-speed Turbine Handpiece Setup" and follow the instructions in the handpiece manual.

### 18.9 High-speed turbine handpiece "air-driven" function

- The "air-driven" function helps clean the treatment area after using the high-speed turbine handpiece. Press the foot switch to release air from the handpiece's water line, eliminating the need to switch to a three-way syringe.

### 18.10 Low-speed dental handpiece

- 1>Used for treatment and surgery.
- 2>For operation, refer to "Low-speed Dental Handpiece Setup" and follow the instructions in the handpiece manual.

18.11 Ultrasonic scaler (optional)

- 1>Used for treatment purposes.
- 2>Operate according to the ultrasonic scaler manual.

18.12 Water and air main switch

Located on the right side of the instrument tray, this switch activates and cuts off the main power, water, and air supply.



Note: Always turn off the water, air, and power main switch when not in use. This is an important safety feature to prevent damage from water leaks.

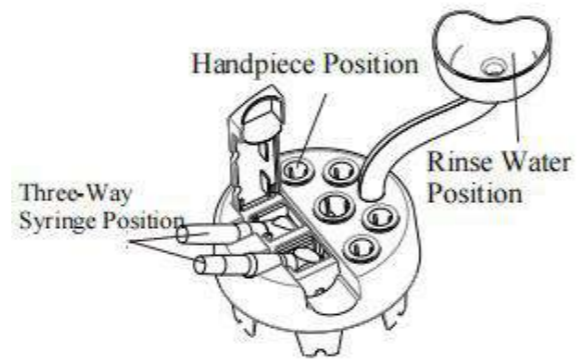

Integrated Cover for Disinfection System

18.13 Tube cleaning switch

Located left of the one-touch water, air, and power switch on the instrument tray, this valve is used to disinfect tubing (handpieces, three-way syringe, scaler, etc.).

Place the handpieces and three-way syringe in the disinfection system cover over the spit bowl. Add 60PPM hypochlorous acid disinfectant to the water bottle, then open the valve to disinfect the tubing until the solution is used up. Afterward, replace with clean water and open the valve to flush the tubes until the water runs out.

(Note: Flushing with clean water is crucial to prevent damage to the water valve.)

18.14 Hanger valve

Automatically activated when the handpiece is lifted from the hanger, without manual selection.

19. Side-mounted auxiliary tray (optional)

- 1>Available in fixed or rotating styles.
- 2>Secured by magnets for quick detachment.
- 3>The rotating tray's flexibility can be adjusted by loosening the side "setscrew" and tightening the damping screw.

Note: Always loosen the set screw before adjusting the damping screw to prevent thread damage.

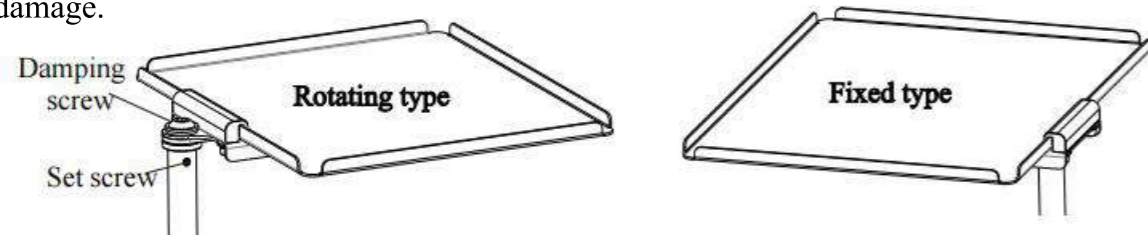

20. Foot pedal switch



F1: Four-hole round foot switch

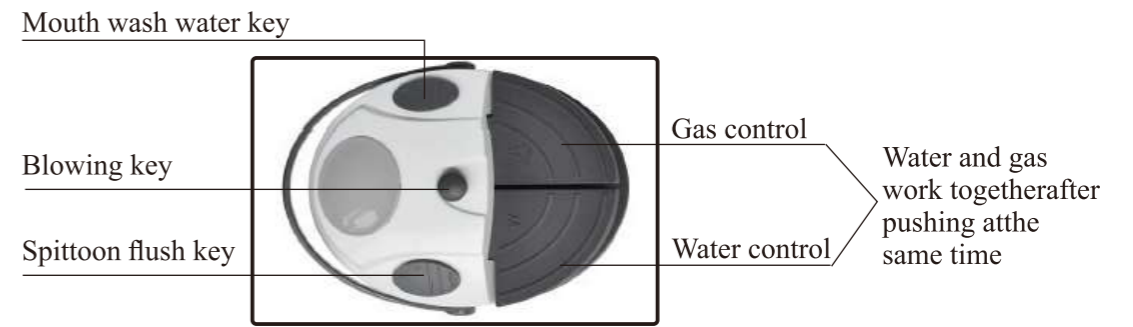

F2: Double pedal foot switch

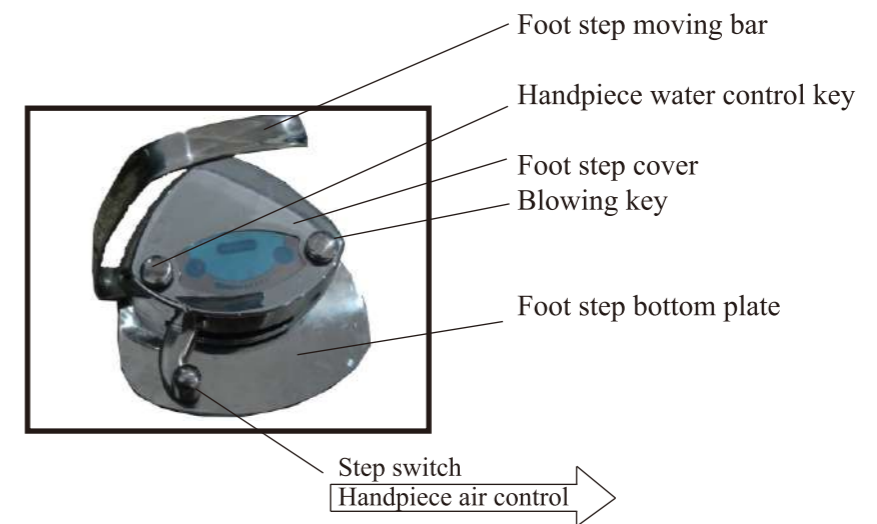

F5: Lever foot switch

## 21.Button membrane

Membrane style

Down-mounted button membrane

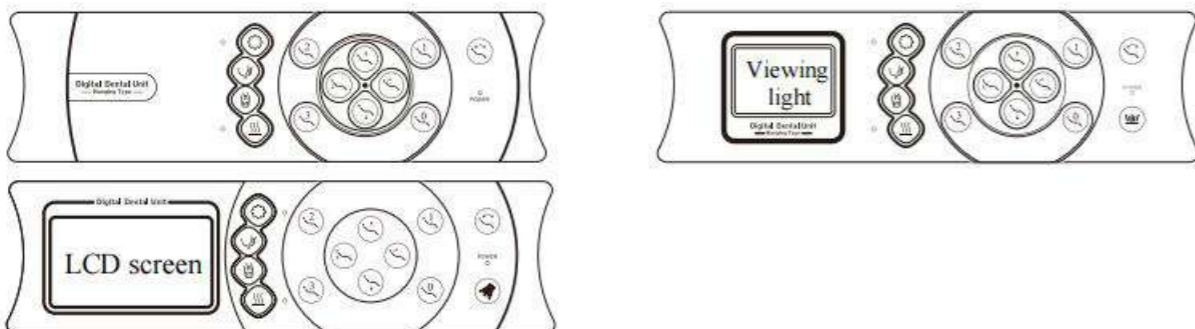

Side-mounted button membrane

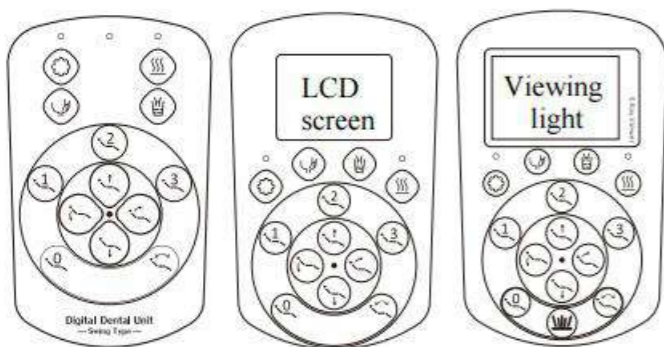

Assistant Control Panel Membrane



### 21.1 Button operation and settings

#### ⚙ Set button

- 1>Main key for all unit settings.
- 2>When active, the LED (green) and the buzzer will flash and beep.
- 3>Settings include: mouthwash, flush water, and S1-S3 memory chair positions.

#### 🚰 Flush water button

- 1>Controls the flush water solenoid valve and flush duration.
- 2>Flush duration setting is as follows:
  - 2.1. Press the set button (SET) for 2 seconds; the buzzer will beep, and the indicator light will turn on, indicating normal setting mode.
  - 2.2. Adjust the flush duration by pressing the flush water button. The buzzer will beep to confirm:
    - 2.2.1. One press: "Beep" – 30 minutes, auto-off.
    - 2.2.2. Two presses: "Beep...Beep" – 60 minutes, auto-off.
    - 2.2.3. Three presses: "Beep...Beep... Beep" – Continuous operation (no auto-off).
    - 2.2.4. Four presses: "Beep...Beep... Beep... Beep" – 12 seconds, auto-off (for testing).
  - 2.3. After setting, press the set button again. The buzzer will beep twice, and the indicator light will turn off, confirming the setting and exiting setup mode.

#### 🚰 Mouthwash button

- 1>Controls the mouthwash solenoid valve and supply duration.
- 2>Mouthwash supply duration setting is as follows:
  - 2.1. Press the set button (SET) for 2 seconds; the buzzer will beep, and the indicator light will turn on, indicating normal setting mode.
  - 2.2. Hold the mouthwash button to start water flow; release when the desired water level is reached to stop the flow.
  - 2.3. Press the set button again; the buzzer will beep twice, and the indicator light will turn off, confirming the setting and exiting setup mode.

#### 🔥 Heated cup button

- 1>Controls the side box water heater's power (on/off).
- 2> The heating indicator light turns on during operation.
- 3>Also controls the mouthwash temperature display on the side box, with adjustable temperature range of 35°C to 45°C.
- 4> Users can set the heating temperature. See the side box temperature adjustment instructions for details.

 Note: Ensure water flow before heating.(Do not heat when water supply is off.)

#### 1 2 3 User memory button

- 1> This device has three user memory positions, each with a preset default position.
- 2> Setting memory positions:
  - 2.1> The three memory positions are set the same way, no specific order.
  - 2.2> Adjust the dental chair to the desired position.
  - 2.3> Press and hold the Set button for 2 seconds, until a "beep" sounds and the LED indicator lights up, indicating the entry to setup mode.
  - 2.4> Press the user memory button (e.g., Position 2), a "beep" will confirm selection.
  - 2.5> Press the Set button again, a double "beep" will confirm saving, and the indicator will turn off, exiting setup mode.

 Note: During operation, pressing any button on the control panel will stop the current action.

### Seat Reset Button

- 1> After treatment, press the reset button, and the dental chair will return to the initial position.
- 2> When activated, the chair will lower to the lowest position, and the backrest will tilt forward to the maximum position.
- 3> The reset button is pre-adjusted at the factory and does not require user settings.

 **Note:** During operation, pressing any button on the control panel will stop the current action.

### pittoon and Rinsing Position Button

- 1> Press to tilt the backrest to its limit for rinsing or spitting.
- 2> Press again to return to the previous treatment position.
- 3> Automatically tracks the last backrest position.
- 4> Cup rinse water activates for one minute when the button is used.

 **Note:** During operation, pressing any button on the control panel will stop the current action.

### Backrest Up Button

- 1> Press and hold to move the backrest forward.
- 2> Release the button to stop the movement once the desired position is reached (the backrest will automatically stop when it reaches the limit if the button is held continuously).

### Backrest Down Button

- 1> Press and hold to raise the chair.
- 2> Release to stop once the desired position is reached (the chair will automatically stop when it reaches the limit if the button is held continuously).

### Chair Up Button

- 1> Press and hold to raise the chair.
- 2> Release to stop once the desired position is reached (the chair will automatically stop when it reaches the limit if the button is held continuously).

### Chair Down Button

- 1> Press and hold to lower the chair.
- 2> Release to stop once the desired position is reached (the chair will automatically stop when it reaches the limit if the button is held continuously).

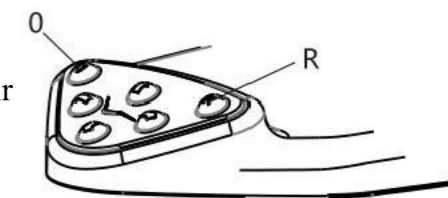

### Universal Key Setup (33-Type Chair Frame)

- The left upper key "0" and right upper key "R" on the foot control are universal keys that can be programmed to any function on the main control panel, except the "Settings" key. To set them:
- 1> Press the "Settings" key for 2 seconds until the LED lights up and you hear a "beep", indicating normal setup mode.
  - 2> Press the universal key you want to program (e.g., left upper key "0").
  - 3> On the main control panel, press the desired function key (e.g., "Rinse" key). The left upper key "0" will now control the "Rinse" function. Press the "Settings" key again to save and exit setup mode.
  - 4> The same process applies to the right upper key "R". Follow steps 2 and 3 to set it.

## 22. Oral Light

### Lamp Head Button Operation

Switch: Controls LED light on/off.

Light Intensity: Switch between high, medium, and low brightness levels.

Max Brightness Settings:

- 1> Ensure light is off, then press both "☀️" buttons for 5 seconds until LED light turns on.
  - 2> There are five brightness levels. Press the right "☀️" button to lower, and the left "☀️" button to increase the maximum brightness.
  - 3> After setting, press the "☀️" button to save and exit.
- Blue Light Cut-off Function

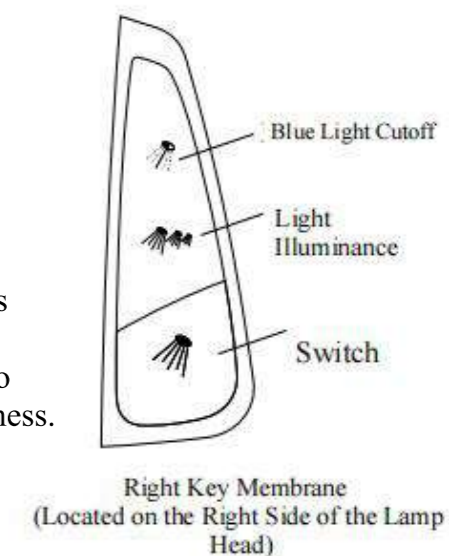

### Infrared Sensor

The 8-series lamp head features two adjustable infrared sensors.

The right sensor controls brightness, while the left controls blue light cutoff.

Wave your hand 2 inches in front of the sensor to activate it.

 **Note:** Direct sunlight or strong light may activate the deactivation sensor. If this happens due to sunlight, shield the sensor or turn it off.

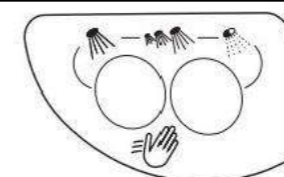

Left sensor

(Located at the bottom of the lamp head)

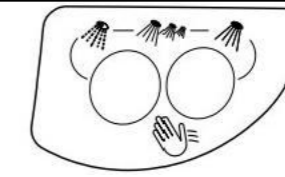

Right sensor

(Located at the bottom of the lamp head)

### The infrared sensor function editing

The sensor can be edited to perform any function from the lamp control panel.

1. Ensure the light is off.
2. To assign a function to the right infrared sensor: press and hold any button on the light control panel for 5 seconds to set that function to the infrared sensor.
3. Repeat the above steps for the left sensor to assign a new function.

To disable the sensor function:

1. Ensure the light is off.
2. To disable the right infrared sensor function, press and hold the "BlueLight Cut-off" and "Light Intensity" buttons for 5 seconds.
3. To disable the left sensor, repeat the same procedure.

To restore the previous function on the sensor, repeat the steps or reassign a new function as instructed.

### The movement direction of the light

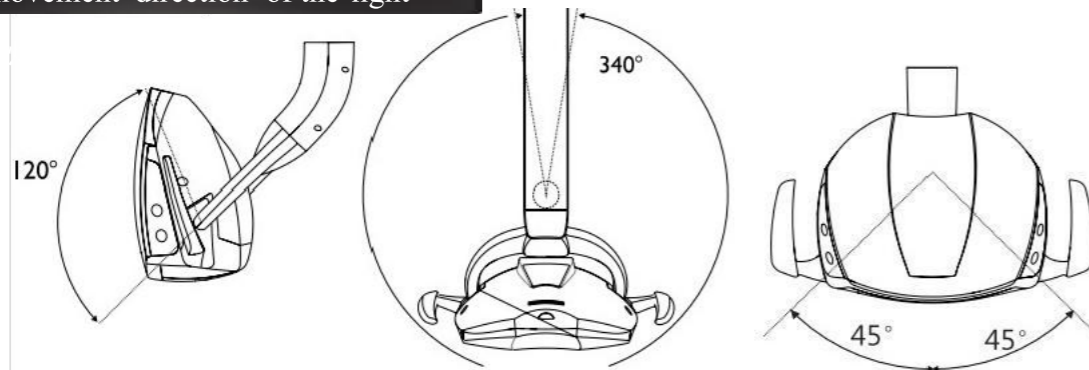

## 23. Equipment Debugging

### 23.1 Input Water, Air, and Power Check

#### 1>Power Check:

Plug in the power socket, press the main power switch, and when the green indicator light turns on, the power is normal.

#### 2>Water Source Check:

Turn on the water source switch. If the device has a "one-click water, air, and power" function, enable it by turning the switch on the right side of the instrument tray. Pick up the three-way syringe from the assistant rack, press the water spray button, and if water sprays out, the water source is normal.

#### 3>Water Filter:

To ensure proper device operation, a water filter is installed at the water inlet. Clean or replace the filter element if the water appears cloudy or after two weeks of use. Refer to "Troubleshooting" for replacement instructions.

#### 4>Air Source Check:

(1) Turn on the air source switch and check the round pressure gauge on the air filter regulator inside the base. The pressure should be 0.55 MPa (preset at the factory).

(2) If the pressure is too high or too low, adjust the air pressure regulator to maintain the correct value:

- a. Open the base cover, pull up the top knob of the air filter regulator, and rotate the knob clockwise to increase pressure or counterclockwise to decrease pressure.
- b. After adjustment, press the knob back down.

(3) Pick up the three-way syringe and press the air spray button. If air comes out, the air source is normal.

### 23.2 High and Low-Speed Air Turbine Handpiece Setup

1>Remove the handpiece from the hanger, step on the footswitch to purge water and air from the hose.

2> Connect the handpiece and follow the instructions in the handpiece manual for setup.

3>Normal working pressure: High-speed 0.22–0.25 MPa; Low-speed 0.30–0.32 MPa (check pressure gauge on the tray).

4>To adjust pressure, use the "Air Pressure Regulator" on the tray. Turn clockwise to lower pressure, counterclockwise to raise it. Adjust carefully.

(Note: Do not run the high-speed handpiece with excessive pressure or idle, as this may shorten its lifespan.)

### 23.3 Three-Way Syringe Setup

1>The left button controls water, and the right button controls air.

2>Pressing the water or air button should release water or air as indicated by the button's graphic.

3>Pressing both buttons simultaneously will release a mist.

4>To dispense hot water or hot mist, activate the heating function on the main control panel.

### 23.4 Dental Chair Setup

1>The dental chair is controlled by three function buttons: the main control panel on the instrument tray, the auxiliary panel on the assistant's arm, and the foot control switch on the chair. Refer to the "Button Operation Instructions" for details.

2>During memory position operation, press any control button to stop the chair's movement.

3>The chair has a safety feature that stops and slightly raises the chair if an obstruction is detected during lowering to prevent accidents.

(Note: The dental chair moves with the treatment unit, so ensure the unit stays within its movement range to avoid contact with other objects and prevent accidents.)

## 23.5 Side Box Horizontal Adjustment

### 1>Front-Mounted Side Box Tray

- 1.1>Level the dental chair by adjusting the silicone pads under the base or using the 4 M16 set screws on the base.
- 1.2>Loosen the 4 M10 hex socket screws and 1 M16 hex screw that fix the side box tray.
- 1.3>Place a level or ruler on the light column.
- 1.4>Due to the heavy weight, the tray screws cannot directly adjust the level. Manually move the light column into position, then adjust the 4 set screws.
- 1.5>After adjustment, tighten the 4 M10 hex socket screws and 1 M16 hex screw, and cover the decorative cap.

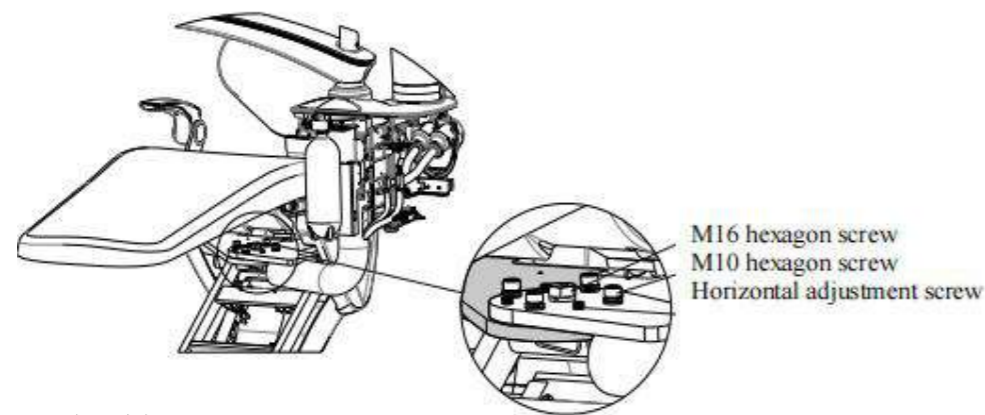

### 2>Rear-Mounted Side Box Tray

- 2.1>Level the dental chair by adjusting the silicone pads under the base or using the 4 M16 set screws on the base.
- 2.2>Loosen the 3 M10 hex socket screws that fix the side box tray.
- 2.3>Place a level or ruler on the light column.
- 2.4>Due to the heavy weight, the tray screws cannot directly adjust the level. Manually move the light column into position, then adjust the 3 set screws.
- 2.5>After adjustment, tighten the 3 M10 hex socket screws to secure the tray.

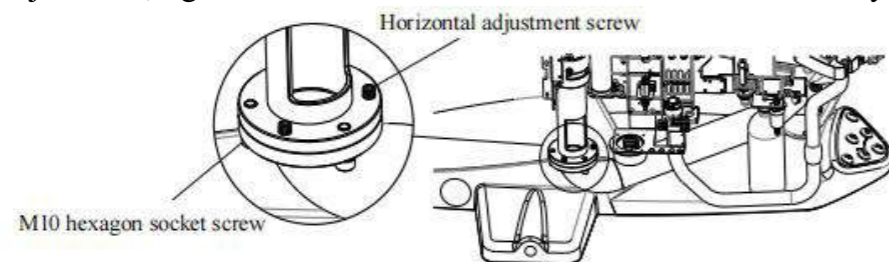

## 23.6 Water Bottle Air Pressure Adjustment

- 1>The air pressure in the water bottle should be around 0.2 MPa.
- 2>Pressure adjustment method:
  - 2.1>Pull up the knob on the top of the air filter regulator, then rotate it. Turn clockwise to increase pressure, counterclockwise to decrease pressure.
  - 2.2>After adjustment, press the knob back down to secure the setting.

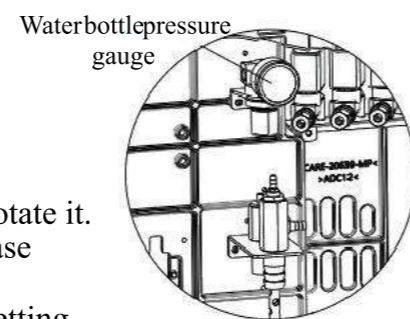

## 23.7 Balance Arm Adjustment

### Balance Arm Tension Adjustment

The balance arm tension is factory preset and can be adjusted upon request. After adjustment, ensure the instrument tray is level.

Remove the end cap from the balance arm. Use an 8mm "Allen wrench (A)" to adjust the internal hex screw. Rotate clockwise to increase the spring tension, and counterclockwise to decrease it.

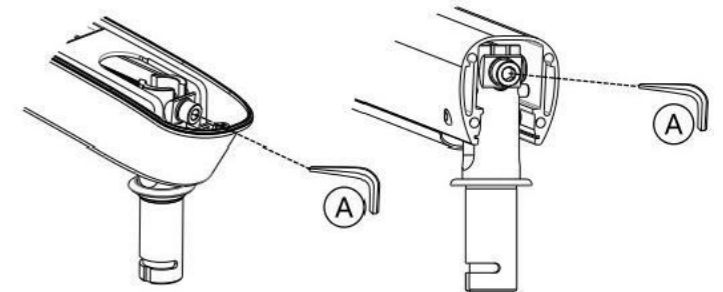

### 23.8 Instrument Tray Level Adjustment

When first installing the dental chair or adjusting the balance spring tension, it's important to level the instrument tray. Ensure the rotating arm or light column is properly aligned before adjustment.

- 1.Remove the front joint decorative cover and loosen the A and B inner hex screws at the front joint.
- 2.Use a small level to adjust the tray angle based on the doctor's preferred working position. Tighten screw A to raise the tray, or screw B to lower it. After adjustment, ensure both A and B screws are tightly secured to avoid wobbling.

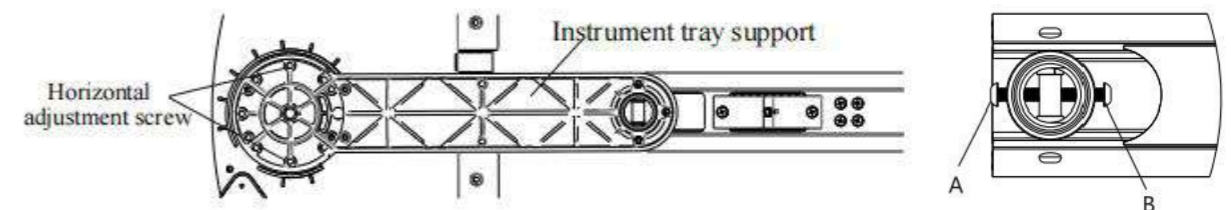

### 23.9 Rotating arm tension adjustment

1>To adjust the tension of the arc-shaped balance arm, loosen the cover screws to expose the internal adjustment screw hole, as shown in the image.

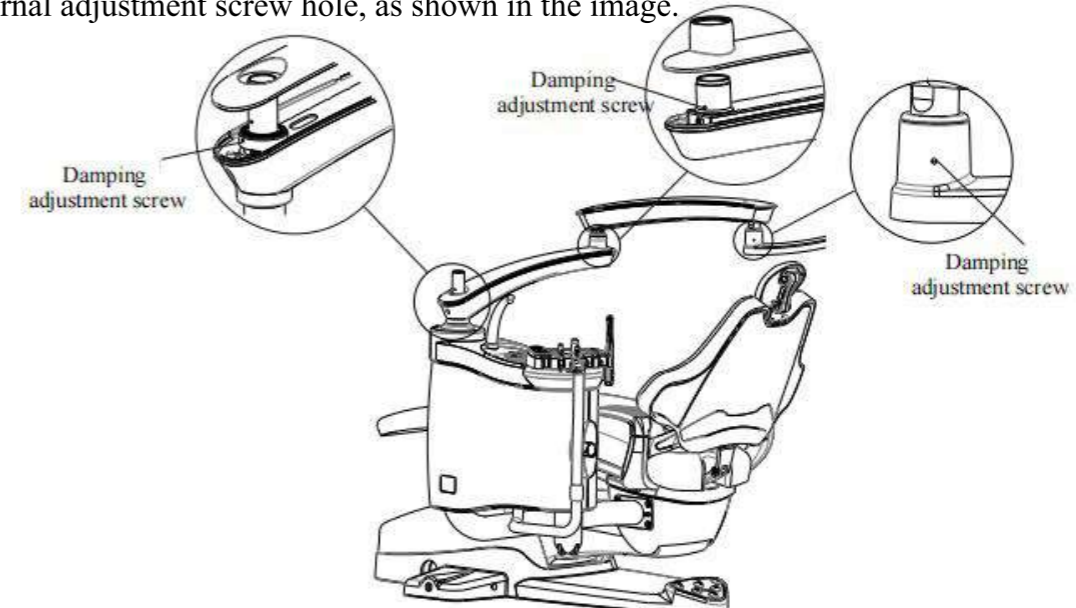

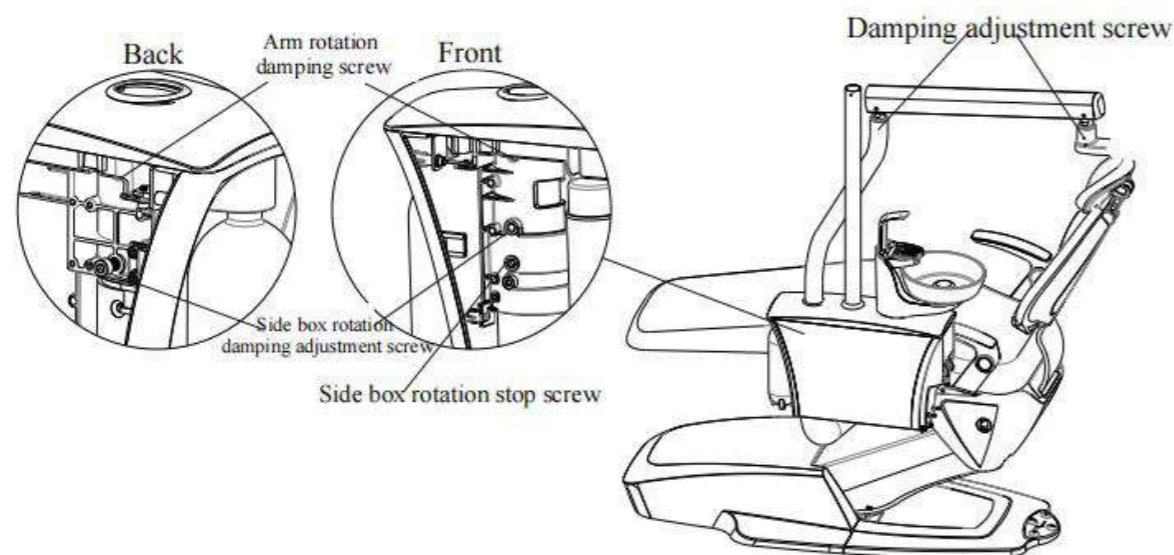

### 23.10 Sputum basin rotation tension adjustment

The adjustment position and method are the same as the arm rotation tension.

Remove the left cover of the side box to access the set screw located on the side of the cast iron where the rotating arm is installed (as shown in the image).



### 23.11 Lamp head rotation tension adjustment

Adjust the set screws at the positions shown in the diagram to modify the lamp head's rotation tension in three directions:

1. Vertical axis rotation tension: 7/64" hex wrench
2. Diagonal axis rotation tension: 7/64" hex wrench
3. Tilt axis rotation tension: 5/64" hex wrench

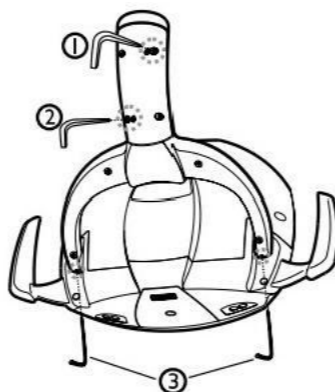

### 23.12 Overhead Instrument Tray Horizontal/Rotation Tension Adjustment

1. If the tray rotates too loosely or too tightly, adjust using the indicated nut in the diagram.
2. Adjust the horizontal angle of the tray using the indicated hex socket set screw in the diagram.

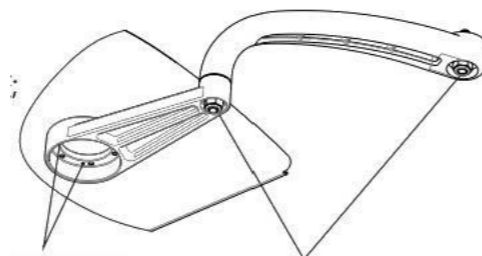

Horizontal Adjustment Screw

Rotation Tightness Adjustment Nut

### 23.13 Lamp Arm Tension Adjustment

- 1>Remove the end cap fixing screws.
- 2>Slide the lamp arm outer casing in the direction indicated by the arrow.
- 3>Insert a 5mm diameter round rod into the adjustment hole and rotate the adjustment nut to adjust the spring tension.
- 4>Use an Allen wrench to adjust the lamp arm's pull resistance.

(Note: The tension of the lamp arm can generally be adjusted directly via the damping screw.)

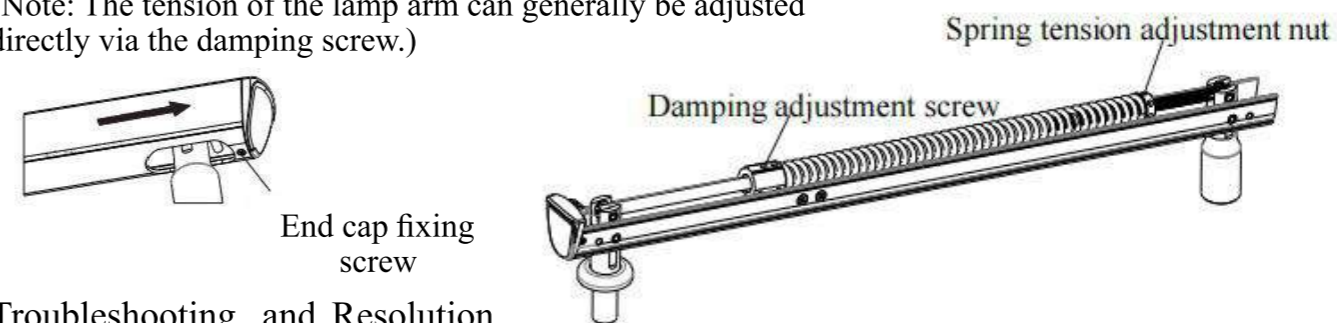

### 24. Troubleshooting and Resolution

Warning: Unauthorized replacement of the fuse or power cord may cause equipment damage. Only manufacturer-authorized personnel should perform replacements.

#### 24.1 No power to the unit

Cause analysis:

- 1>Power switch is off.
- 2>Circuit fuse is blown.
- 3>Main power cord is damaged

Solution:

- 1>Turn on the power switch.
- 2>Replace the fuse. To replace the fuse:
  - 2.1>Disconnect the power.
  - 2.2>Unscrew the fuse holder counterclockwise and remove the fuse.
  - 2.3>Install a new fuse (refer to the fuse specification on the power box label), then screw the holder clockwise to secure it.
- 3>Replacing the main power cord:
  - 3.1>Disconnect the power.
  - 3.2>Use a Phillips screwdriver to loosen the terminal block, disconnect the main power cord connector, and remove the old power cord.
  - 3.3>Insert the new power cord into the connector, tighten it, and secure the terminal block.

## 24.2 No movement or adjustment

- 1>Verify the device is powered on.
- 2>Check if the emergency stop switch is pressed or if the emergency stop switch wiring is properly connected to the power box transformer.
- 3>Ensure the one-key water, gas, and electricity main switch is turned on.
- 4>Diagnose whether the issue is with the motor or the mainboard by testing the lifting motor and backrest motor.

## 24.3 Water in the air system

- 1>Check if the condensation water in the air filter has been properly drained.
- 2>Inspect the main air circuit for any water.
- 3>Verify if the diaphragm in the air control valve is damaged.
- 4>Check the diaphragm valve by pinching the water inlet pipe and confirm if the air system stops releasing water.

## 24.4 Air in the water system

- 1>Check the main water circuit for air.
- 2>Verify if the water reservoir is empty.

## 24.5 Low speed or weak performance of the high-speed turbine handpiece

### Cause Analysis:

1. Insufficient air supply pressure.
2. Faulty handpiece bearing.

### Solution:

1. Adjust the air supply pressure to the handpiece (working pressure: 0.22MPa–0.25MPa).
2. Replace the handpiece bearing according to the high-speed turbine handpiece manual.

## 24.6 Low-speed handpiece not rotating or rotating too slowly.

### Cause Analysis:

1. Insufficient air supply pressure.
2. Incorrect position of the speed and direction adjustment ring on the low-speed turbine handpiece.

### Solution:

1. Adjust the air supply pressure to the handpiece (working pressure: 0.3MPa – 0.32MPa).
2. Rotate the adjustment ring to set the appropriate speed and direction.

## 24.7 Insufficient suction power of the high-power suction device

### Cause Analysis: Suction tube blockage.

Solution: Clean the suction tube and remove any blockages.

## 24.8 Insufficient suction power of the saliva ejector

### Cause Analysis:

1. Blockage in the saliva ejector tube.
2. Low water pressure.

### Solution:

1. Clean the saliva ejector tube and remove any blockages.
2. Check the water filter cartridge, clean or replace it.
3. Open the suction converter valve located below the side box to switch the suction power source from water to compressed air.

## 24.9 Drainage of the cup filler is poor

### Cause Analysis:

1. Clogged drainage pipe.
2. The plastic pipe is compressed.

### Solution:

1. Clean the drainage pipe and remove the dirt in the pipe.
2. Replace the new drain pipe.

### 24.10 Simple troubleshooting

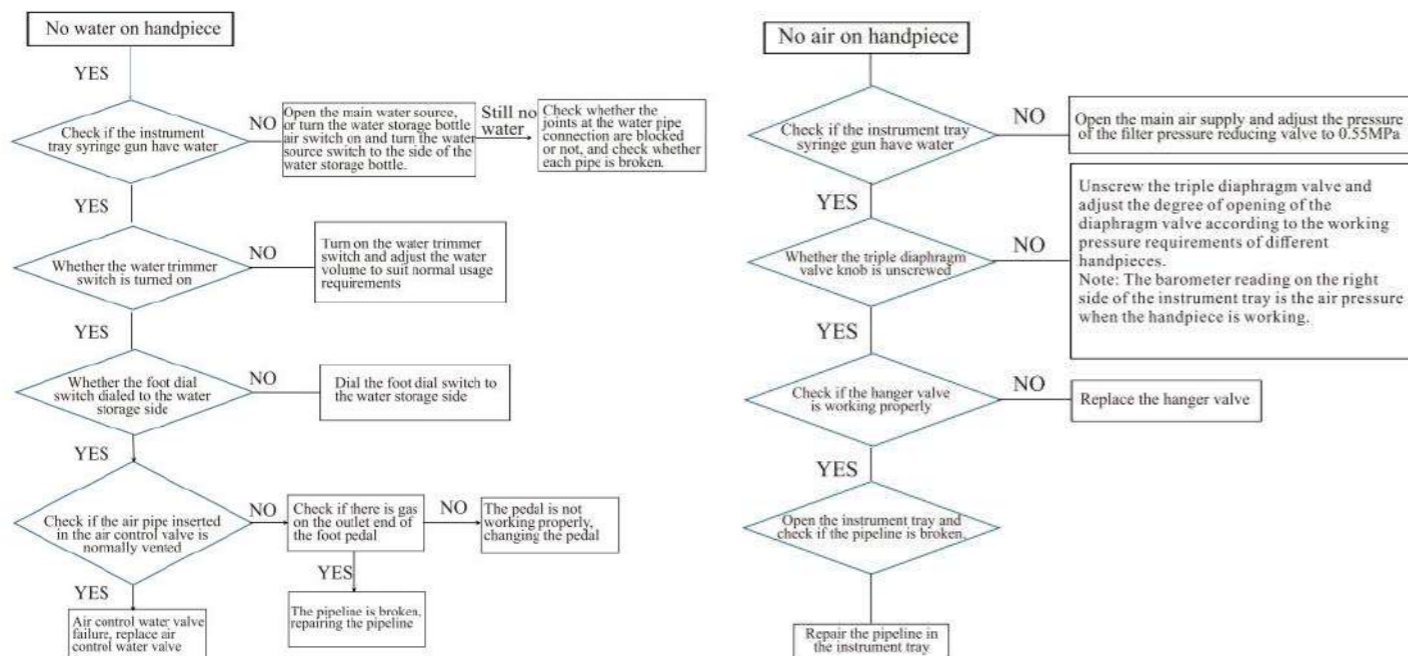

### 25. Maintenance and Care

Regular upkeep of integrated dental treatment units reduces malfunctions, maintains optimal performance, and extends equipment lifespan.

#### 25.1 Maintenance of Treatment Unit and Dental Chair

Daily cleaning of the dental unit and chair should be conducted using a neutral detergent, ensuring the detergent does not damage the equipment surfaces. Use mild detergent with warm water for cleaning. Certain medical disinfectants can also be used, though repeated use of some disinfectants may lead to surface discoloration. Following the cleaning instructions in the manual and using soap solutions can reduce discoloration risks. Avoid powdered cleaners, abrasive sponges, or abrasive cleaners on any coated, plastic, or metal surfaces. Use a soft brush and mild detergent for surface cleaning.

#### 25.2 Maintenance and Care for High- and Low-Speed Handpieces

1. Clean and lubricate turbine handpieces daily before and after use with handpiece cleaner and lubricant to maintain internal cleanliness and lubrication.
2. Do not operate the handpiece without a bur installed.
3. Regularly check the operating pressure to ensure it remains within the recommended range.
4. To prevent cross-contamination, disinfect and sterilize after each procedure:
  - 4.1. Brush the surface clean, then wipe with disinfectant alcohol.
  - 4.2. Use handpiece cleaner and lubricant for internal cleaning and lubrication.
  - 4.3. Package in a sterilization pouch, marking the date.
  - 4.4. Sterilize in an autoclave at or below 134°C (do not exceed 134°C).

### 25.3 Maintenance and Care for Three-Way Syringe Tip

1. Each three-way syringe is equipped with a nozzle. To remove the nozzle, press the large ring and pull it out. To install, press the ring down until you hear a "click," indicating proper installation.
2. Use the syringe nozzle tip to press and remove the stop pin for regular maintenance or replacement of the O-rings.
3. If the syringe leaks water or air, the O-ring may be damaged. Refer to the table for the correct O-ring specifications.
4. After ultrasonic cleaning, place the syringe tip in a sterilization bag and sterilize at high temperature and pressure (maximum sterilization temperature is 134°C).

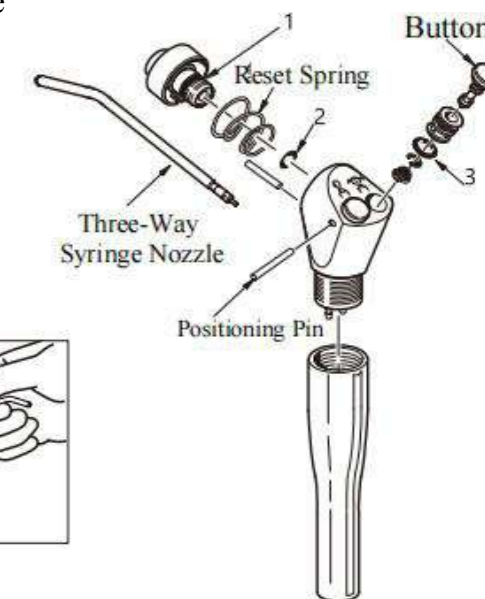

Name	Specification (Outer Diameter X Cross-Section Diameter)
O-Ring #1	48 x 1 mm
O-Ring #2	44.65 x 1.5 mm
O-Ring #3	46.1 x 1.8 mm

**!** Note: Turn off the main air and water supply before removing the button to prevent it from being ejected by high-pressure water or air.

#### 25.4 Maintenance and Care of Strong (Weak) Suction Units

Before each use, wipe with disinfectant alcohol and suction a certain amount of disinfectant solution to ensure the cleanliness of the tubing.

#### 25.5 Maintenance and Care of Ceramic Bowl Drainage Pipe

1. The ceramic bowl filter mesh should be cleaned daily.
2. Rinse the ceramic bowl with plenty of clean water daily to prevent blockage of the drainage pipe.

#### 25.6 Maintenance and Care of Air Pressure Regulator

Drain the air filter once a week.

#### 25.7 Maintenance and Care of Water Filter

Clean the water filter every 6 months to 1 year (or based on water quality and usage frequency, clean or replace as needed).

#### 25.8 LED Light Head Maintenance

##### Basic Cleaning

Use mild detergent with warm water for cleaning. Medical disinfectants can also be used, but repeated use may cause surface discoloration. Frequent cleaning with soapy water, as per the manual instructions, helps reduce discoloration.

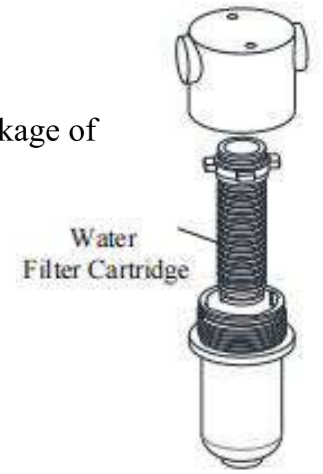

**!** Note: Never use powdered cleaners, abrasive sponges, or scouring pads to clean any spray-painted, plastic, or metal surfaces. Use a soft-bristled brush and mild detergent to clean surfaces.

### Reflector Cleaning

#### Reflector Bowl Cleaning Instructions

1. Dampen a clean, soft, lint-free cloth with mild detergent and distilled water.
  2. Gently wipe the reflector bowl in one direction (either horizontal or vertical).
  3. Use a clean, dry, soft, lint-free cloth to dry the reflector bowl.
- These steps will help prevent scratching the surface of the reflector.

#### Transparent cover replacement

Use mild detergent with warm water for cleaning. Medical disinfectants can also be used, but repeated use may cause surface discoloration. Frequent cleaning with soapy water, as per the manual instructions, helps reduce discoloration.

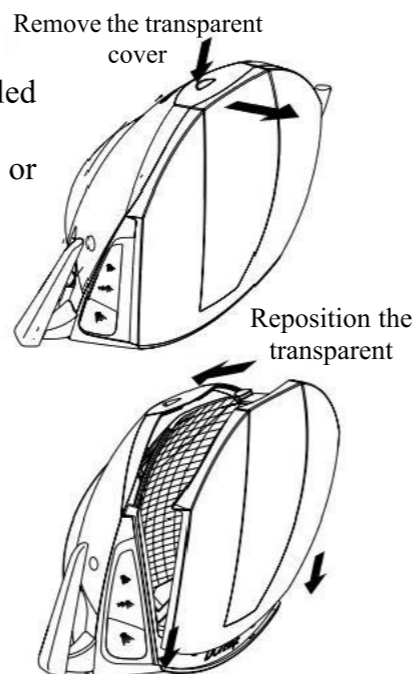

## 26 Cleaning, sterilization and disinfection

### Protective film

Whenever possible, disposable isolation pads (protective films) should be used between patients. These isolation pads (protective films) will ensure the long-term durability of the equipment's surface.

### Chemical disinfection

Disinfection control in dental offices is crucial for both clients and end users. OSHA, ADA, and CDC provide guidelines for this process. Manufacturers do not specify exact disinfection intervals or validate surface disinfection. For more details, refer to ADA infection control recommendations.

When disinfecting instruments, chemical disinfectants are not always necessary. While they may be quick and convenient, it's important to understand the effectiveness and potential chemical reactions of different disinfectants.

### Sterilization

Several sterilization methods can be used. Ensure that the temperature does not exceed 275°F (135°C). The following methods are suitable for disinfecting instruments:

- 1 High pressure steam sterilization
- 1 Ethylene oxide gas
- 1 Chemical steam process

Never let instruments touch the sterilizer's inner walls or heating elements. Dry heat sterilization is not recommended due to difficulty in controlling temperature accurately.

[www.runyes.com](http://www.runyes.com)

### Normal cleaning

Use mild detergent with warm water to clean the equipment. Some clinic disinfectants can also be used, but repeated use may cause surface discoloration. Following the manual's cleaning instructions and using soapy water regularly can minimize discoloration.



Note: Do not use powdered cleaners, sponges, scouring pads, or abrasive cleaners to clean any plastic, metal, or sprayed surfaces. Use a soft brush and mild detergent for cleaning the surface.

### PU Surface Cleaning

Touch surfaces are areas that come into contact during dental procedures and can become potential cross-contamination points.

Transfer surfaces are surfaces contaminated by contact with instruments or other non-moving objects.

DCI recommends using isolation protection for all relevant touch and transfer surfaces. Isolation materials must comply with GMP standards to ensure effective protection. Please consult local regulatory authorities for isolation protection guidelines. After treating each patient, discard the isolation plastic film.

For cleaning and chemical disinfection of touch and transfer surfaces (where isolation protection is not used or if damaged), follow the recommended procedures.

Acceptable disinfectants:  
Phthalaldehyde/Quaternary ammonium/  
Glutaraldehyde

Note: These disinfectants will damage the surface of the equipment. The following disinfectants are not recommended:  
Strong phenols/phenol-alcohol mixtures  
Sodium hypochlorite/household bleach  
Sodium bromide  
High concentration alcohol  
Household cleaners (for dental equipment only)  
Citric acid  
Iodine tinctures  
Sodium chloride  
Hydrogen (0.5%)

NOTE: When using a chemical sterilization autoclave process, flush all cleaning agents out with water, and use water (not isopropyl alcohol) to flush residual cleaning agents from internal surfaces and channels. This will prevent crystals from forming between the autoclave solution and the cleaning agents.

Disinfect leather surfaces daily using 3% hydrogen peroxide, leather conditioner, and 3% enzymatic disinfectant. Follow the instructions and wipe with clean water.



Prohibited: The use of alcohol, glutaraldehyde, 84 disinfectant, benzalkonium bromide, benzalkonium chloride alcohol disinfectants, and any acidic or alkaline disinfectants. These can cause leather cracking and aging, which are not covered under warranty.

#### Assistant Arm Negative Pressure Tubing Cleaning

After Patient Use: Rinse each valve with clean water by opening and closing several times. Keep it open for a few seconds to flush the lines.

Sterilize and replace strong/weak suction tips after each patient.

End of Day: Rinse each valve with disinfectant. EcoVac is an efficient, non-toxic, eco-friendly suction disinfectant.

#### - Handpiece cleaning - daily care

The dental unit features a handpiece flushing system to periodically flush the handpiece tubes with clean water, preventing microbial film growth caused by low water flow.

It is recommended to flush the tubes daily, both before and after use. Flushing can be done with or without a handpiece, though using the handpiece will require longer flushing time due to limited water flow.

Flush all handpiece tubes simultaneously, directing them toward a sink or spittoon. Activate the flush valve and allow sufficient time for the system to replace stagnant water with clean water.

For further recommendations, consult the American Dental Association or CDC regarding flushing frequency, duration, and disinfectant use.



Warning: To prevent cross-contamination, sterilize and disinfect the handpiece after each use. Refer to the manufacturer's instructions for proper sterilization and disinfection.

#### Normal cleaning

Clean the PU surface with a 10% soap and warm water solution using a soft cloth. Rinse with clean water and wipe dry. Clean between patients, or based on usage frequency.

For stains: Use Formula 409 or Fantastik with a soft cloth or brush. Rinse and dry.

For tough stains: Use lighter fluid or rubbing alcohol, gently wipe, rinse, and dry.

Notes: Avoid paper towels. Test strong cleaners on a hidden area first. Do not use industrial-grade solvents. Restore gloss with furniture wax and wipe after 30 seconds.

#### Dental unit part - Weekly maintenance

Perform maintenance weekly, or immediately before and after use if the unit only temporarily stores water.

1. Purify the system with air.
2. Rinse with disinfectant:
  - a. Turn off the main switch, empty the water storage bottle, and refill with disinfectant.
  - b. Place the handpiece and three-way gun on the spittoon, turn on the main switch, and activate the flushing valve, three-way gun, and foot switch until disinfectant flows out.
3. Let the disinfectant sit for 10-20 minutes, then flush the system until clean.
4. Purify the system with air:
  - a. Activate the flushing valve, three-way gun, and foot switch until disinfectant is expelled.
  - b. Turn off the main valve.
5. Refill with clean water:
  - a. Replace the disinfectant bottle with a water bottle filled with clean water.
  - b. Activate the system until clean water flows out, then repeat for the three-way gun.

#### Handpiece Oil Collector

Replace the used oil-absorbing cotton with clean cotton at least every 90 days, or more frequently if the handpiece becomes greasy. To remove the oil collector, press and pull it downwards.

#### Suction collector

Turn off the suction machine, remove the decorative cover of the suction filter, and lift out the filter. If the filter contains a lot of debris, it should be cleaned more frequently.



#### Self-contained water storage system

The self-contained water storage system optimizes water quality for the handpiece and three-way gun. It serves three functions:

1. Stores distilled or sterile water.
2. Stores disinfectant for flushing the three-way gun and handpiece tubes.
3. Purifies air in the unit to inhibit microorganism growth.

To maintain a sterile system, follow daily and weekly cleaning steps. Improper maintenance may contaminate the water system and reduce water quality. Regular maintenance of all pipelines is required.

**Water bottle disinfection**

 **Note: Sterilize new water bottles before first use**

**Disinfection solution:** Mix 9 cups (90 ml) tap water with 1 cup (10 ml) 5.25% sodium hypochlorite (household bleach)

Pour 100 ml of disinfectant into the bottle, shake vigorously, let it sit for 10 minutes, shake again, and rinse with water twice.

**Electromagnetic Interference**

**Electronic Medical Devices**

Electronic medical devices are subject to EMC safety standards and must be installed according to the provided instructions.

**Portable Electronic Devices**

Portable and mobile high-frequency communication devices may interfere with electronic medical equipment.

**Electrostatic Sensitive Equipment**

Equipment marked as electrostatic-sensitive requires special precautions during handling.

At a minimum, use a grounded wrist strap to reduce the risk of damage.

**Use of Accessories**

Using non-specified accessories may increase electromagnetic emissions and reduce system immunity.

**27.Waste Disposal**

To reduce environmental pollution, send recyclable parts to recycling centers after removing hazardous substances. Recyclers are responsible for product disposal. Dispose of hazardous materials per regulations, using protective measures to prevent injury.

△Recyclable ▲Recyclable after processing

Components and parts	Main materials	Recyclable materials	Waste treatment center	Hazardous materials separated and recycled
Shell Chair frame	ABS	△		△
	Aluminum, Iron	△		
Circuit board		▲		
Wire	Copper	△		
Packaging	Paper	△		
Other			△	

**28.Circuit Schematic**

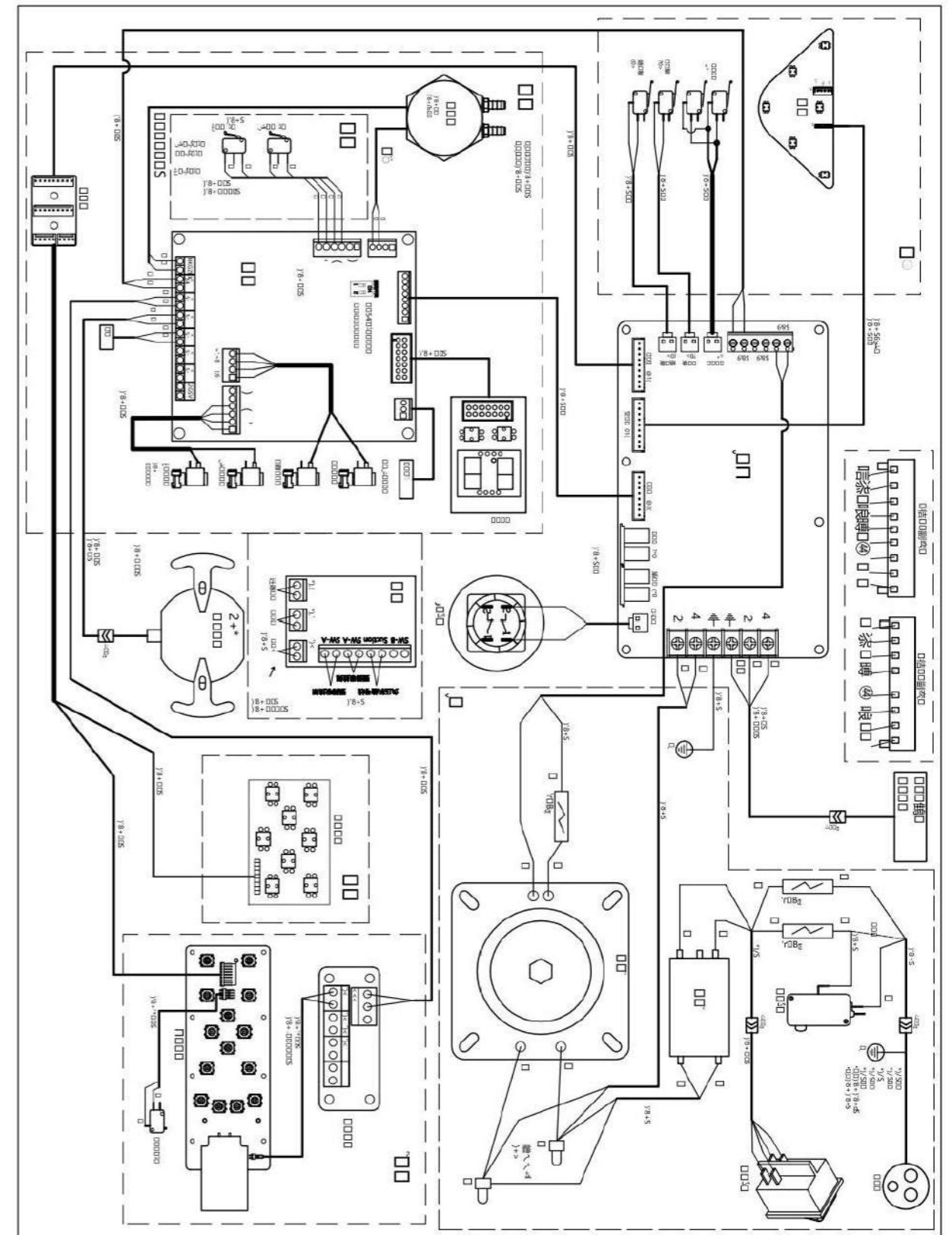

### 29. Electromagnetic compatibility

△ Note:

This equipment complies with the electromagnetic compatibility (EMC) requirements of YY 9706.102-2021.

Special EMC precautions must be taken, and the equipment must be installed and used according to the EMC information provided in this manual.

Portable and mobile RF communication devices may affect this equipment.

● The following cables must be used to meet requirements for electromagnetic emission and immunity:

Cable name	Cable length (m)
Power cable	1.6

△ Warning:

Using unapproved accessories or cables (transducers), other than those sold as spare internal components, may increase emissions or reduce immunity of the ME equipment or system.

ME equipment or systems should not be used in close proximity to or stacked with other devices. If such use is necessary, verify normal operation in the intended configuration.

● Basic performance:

This product has no basic performance.

Guidelines and Manufacturer's Declaration – Electromagnetic Emissions		
Care-11, Care-22, Care-33, and Care-66 are intended for use in the electromagnetic environments specified below. The purchaser or user should ensure that the devices are used in these environments.		
Emission Test	Compliance	Electromagnetic Environment – Guidance
RF Emission GB 4824	Group 1	The Care-11, Care-22, Care-33, and Care-66 devices use radio frequency energy only for internal functions. Therefore, their radio frequency emissions are very low, and the likelihood of interference with nearby electronic devices is minimal.
RF Emission GB 4824	Class B	The Care-11, Care-22, Care-33, and Care-66 are suitable for use in all facilities, including homes and directly connected to the public low-voltage power supply network for residential use.
Harmonic Emission GB 17625.1	Class A	
Voltage Fluctuation/Flicker Emission GB/T 17625.2	Compliant	

Guidance and Manufacturer's Declaration – Electromagnetic Immunity			
The Care-11, Care-22, Care-33, and Care-66 are intended for use in the electromagnetic environments specified below. The purchaser or user should ensure that the equipment is used in such environments:			
Immunity Test	Test Level	Compliance Level	Electromagnetic Environment – Guidance
Electrostatic Discharge (ESD) GB/T 17626.2	±6kV contact discharge, ±8kV air discharge	±6kV contact discharge, ±8kV air discharge	The floor should be wood, concrete, or ceramic tiles. If the floor is covered with synthetic materials, the relative humidity should be at least 30%.
Fast Transient/Burst GB/T 17626.4	±2kV for power lines ±1kV for input/output lines	±2kV for power lines	The power network should meet the typical quality used in commercial or hospital environments.
Surge GB/T 17626.5	±1kV line-to-line ±2kV line-to-ground	±1kV line-to-line ±2kV line-to-ground	The power network should meet the typical quality used in commercial or hospital environments.
Voltage dips, short interruptions, and voltage variations on power input lines GB/T 17626.11	<5% U, duration 0.5 cycle (on UI, >95% dip) 40% U, duration 5 cycles (on U, 60% dip) 70% U, duration 25 cycles (on U, 30% dip) <5% U, duration 5s (on U, >95% dip)	<5% U, duration 0.5 cycle (on UI, >95% dip) 40% U, duration 5 cycles (on U, 60% dip) 70% U, duration 25 cycles (on U, 30% dip) <5% U, duration 5s (on U, >95% dip)	The power network should meet the quality typical for commercial or hospital environments. If continuous operation is required during power interruptions, it is recommended to use an uninterruptible power supply (UPS) or battery power for Care-11, Care-22, Care-33, and Care-66.
Power frequency magnetic field (50Hz) GB/T 17626.8	3 A/m	3 A/m	The power frequency magnetic field should be characteristic of the typical magnetic field levels found in commercial or hospital environments.

Note: U- refers to the AC mains voltage before applying the test voltage.

**Recommended isolation distances between portable and mobile RF communication equipment and Care11, Care22, Care33, Care66**

Care-11, Care-22, Care-33, and Care-66 should be used in environments with controlled radio frequency interference. To prevent electromagnetic interference, maintain the recommended minimum distance between portable/mobile RF devices (transmitters) and Care-11, Care-22, Care-33, and Care-66 based on the device's maximum output power.

Maximum rated output power of the	Isolation distance corresponding to different transmitter frequencies/m		
	150kHz - 80MHz $d=1.2 \sqrt{P}$	80MHz - 800MHz $d=1.2 \sqrt{P}$	800MHz -2.5GHz $d=2.3\sqrt{P}$

transmitter/W			
0.01	0.12	0.12	0.23
0.1	0.38	0.38	0.73
1	1.2	1.2	2.3
10	3.8	3.8	7.3
100	12	12	23

For transmitters not listed in the table, the recommended separation distance  $d$  in meters can be calculated using the formula for the corresponding frequency.  $P$  is the maximum output power in watts from the transmitter manufacturer.

Note 1: For 80 MHz and 800 MHz, use the formula for the higher frequency band.  
 Note 2: These guidelines may not apply in all cases due to absorption and reflection by buildings, objects, and people.

**Guidance and Manufacturer's Statement — Electromagnetic Immunity**

Care-11, Care-22, Care-33, and Care-66 are intended for use in the following specified electromagnetic environments. Buyers or users should ensure they are used in such environments:

Immunity Test	Test Level	Compliance Level	Electromagnetic Environment - Guidance
Radio Frequency Conduction GB/T 17626.6-2017 Radio Frequency Radiation GB/T 17626.3	3V (RMS) Frequency Range: 150kHz - 80MHz: 3V/m 80MHz - 2.5GHz: 3V/m	3V(effective value) 3V/m	<p>Portable and mobile radio frequency communication devices should not be placed closer than the recommended isolation distance to any part of the Care-11, Care-22, Care-33, or Care-66 equipment, including cables. The distance is calculated using the following formula based on the transmitter frequency:</p> <p>Recommended Isolation Distance:  <math>d = 1.2 / \sqrt{P}</math> (150kHz - 80MHz)  <math>d = 1.2 \times \sqrt{P}</math> (80MHz - 800MHz)  <math>d = 2.3 / \sqrt{P}</math> (800MHz - 2.5GHz)</p> <p>Where:                      P = Maximum rated output power of the transmitter, in watts (W)                      d = Recommended isolation distance, in meters (m)</p> <p>For fixed radio frequency transmitters, the field strength is determined by electromagnetic field surveys and should be below the compliance level at each frequency range.</p> <p>Interference may occur near devices marked with the following symbols: </p>

Note 1: For frequencies between 80MHz and 800MHz, use the formula for the higher frequency range.  
 Note 2: These guidelines may not apply in all situations, as electromagnetic propagation is influenced by absorption and reflection from buildings, objects, and the human body.

a) Fixed transmitters, such as base stations for wireless phones and radio broadcasts, have unpredictable field strengths. Field surveys should be done to assess the environment. If the field strength exceeds compliance levels, monitor the device and adjust its position if needed.

b) For 150kHz to 80MHz, the field strength should be below 3V/m.

## 30. Treatment machine standard packing list

No.	Item Name	Unit	Quantity	Remarks
1	Dental Treatment Unit	Set	1	
2	Doctor's Chair	Piece	1	
3	Oral Light and Accessories	Set	1	
4	Lamp Pole and Accessories	Set	1	
5	1000ML Water Bottle	Piece	1	
6	Three-way Gun Nozzle	Piece	2	
7	Sink Supply Pipe	Piece	1	
8	Mouthwash Supply Pipe	Piece	1	
9	O-ring (d5×41.8, d5×41.5)	Piece	2	
10	Strong Suction Tip	Piece	1	Additional suction tip included
11	Weak Suction Tip	Piece	2	
12	Sink Plastic Parts	Set	1	
13	Ceramic Sink Cover	Piece	1	
14	08X1.5 Pressure Hose (Blue)	Meter	1	Air supply hose
15	28X1.5 Pressure Hose (Transparent)	Meter	1	Water supply hose
16	1/2 Connector	Piece	2	
17	1/2 Check Valve	Piece	2	
18	1/4 Ball Valve	Piece	2	
19	1/4 Connector	Piece	4	
20	Fuse	Piece	2	T15AL.T5AH.T8AL
21	Strong/Weak Suction Decoration Plate	Piece	1	
22	Lamp Tube Decoration Cover	Piece	2	
23	Product Manual	Copy	1	
24	Quality Assurance Certificate	Copy	1	Domestic use
25	Certificate of Conformity	Copy	1	
26				

## 30.1 Treatment machine configuration

No.	Configuration	Quantity	Function Description	Remarks
1	High-speed Air Turbine Handpiece (Optional)	2 sets	Equipped with blow-off and anti-backflow functions	
2	Dental Low-speed Handpiece (Optional)	1 set	Includes straight and angled handpieces	
3	Three-way Spray Gun	2 sets		
4	Mouthwash Water Supply System	1 set	Adjustable range: 30°C~45°C	
5	Oral Light	1 set		
6	X-ray Viewer (Optional)	1 set		
7	Spittoon	1 set		
8	Rotatable Side Box	1 set	Convenient for four-handed operation	
9	Saliva Ejector	1 set	With delay function	
10	Strong Suction Device (Optional)	1 set	With delay function	
11	Handpiece Water Purification System	1 set		
12	Medical Foot Pedal Switch	1 set	Innovative design, flexible operation	
13	Dental Doctor's Chair	1 set	Ergonomic backrest design, both aesthetic and practical	

