



Airstream®



cen
EN 12469
EN 12469, SANS 12469

Airstream® Class II, Biosafety Cabinet, Model AC2-4E...

S2 Class II Biological Safety Cabinets

The World's Most Energy-Efficient, Quiet and Compact Biosafety Cabinet



ESCO
SCIENTIFIC



RS 232 SERIAL
INTERFACE PORT



Zero voltage
relay contact

RS 232 Port and Zero Volt Relay Contact

- RS 232 Port to send operational information to Building Management System (BMS)
- Zero Volt Relay Contact to turn ON/OFF exhaust blower and signal the building alarm

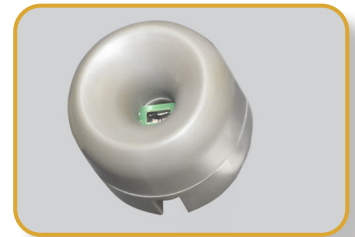

Sentinel™ Gold Microprocessor Controller

- Displays all safety information on one screen
- Centered and angled down for easy reach & viewing
- Selectable Quickstart mode for fast operation



S12

Angled Corner & Glass Side

- Easy to clean
- Easy to reach service fixture and outlets
- Stainless steel side wall is available (AC2-S and AC2-D variant)



S14

Divided Work Tray

- Easy to lift and clean
- Single-piece recessed tray is available (AC2-S and AC2-D variant)



Raised Arm Rest

- Helps prevent grille blocking
- Comfortable working posture



Removable Paper Catch

- Easy to clean
- Optional pre-filter can be fitted



Available in 0.6, 0.9, 1.2, 1.5, and 1.8 meter width

Airflow Sensor

- Monitors real-time airflow for safety
- Alerts the user if airflow is insufficient

Energy-Efficient DC ECM Motor

- The most energy-efficient Class II biosafety cabinet in the world, provides 70% energy savings compared to AC motor
- Stable airflow, despite building voltage fluctuations & filter loading
- Night Setback mode to further reduce power consumption by 60%



S18



S10

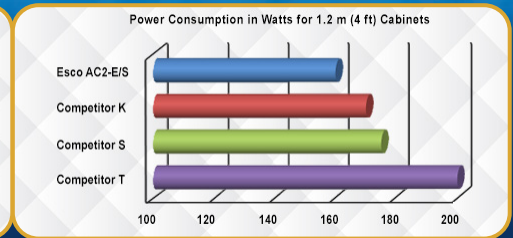
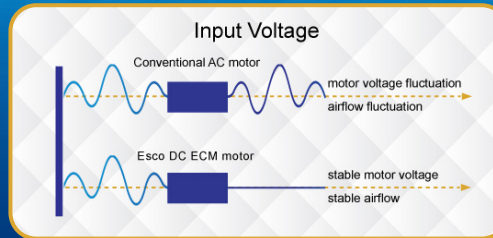

ULPA Filter

- 10x Filtration efficiency of HEPA filter
- Creates ISO Class 3 work zone instead of industry-standard ISO Class 5

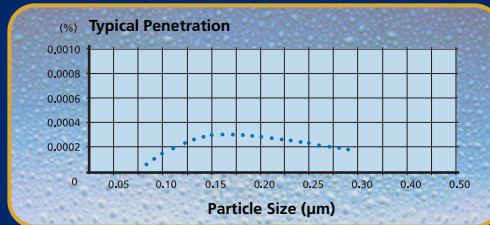

Esco cabinets use ULPA filters (per IEST-RP-CC001.3) / H14 per EN 1822 instead of H13 HEPA filters used on many BSCs in the market.

HEPA filters only offer 99.99% typical efficiency at 0.3 micron, while ULPA filters provide 99.999% typical efficiency for particle sizes of 0.1 to 0.3 micron.

Dynamic Chamber™

- Blower plenum and side walls (AC2-S and AC2-D variant)
- Prevent contaminants from escaping outside

- Positive pressure
- Negative pressure

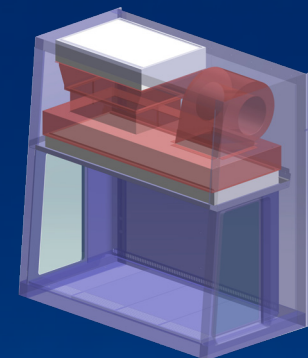

3

ISOCIDE™ Powder Coat

- Silver-ion impregnated powder coat
- Inhibit microbial growth to improve safety

S11

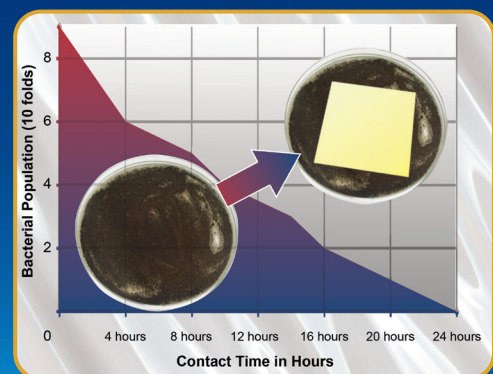

S24

Standards Compliance	Biosafety Cabinet	Air Quality	Filtration	Electrical Safety
	EN 12469, Europe SANS 12469, South Africa	ISO 14644.1 Class 3, Worldwide JIS B9920 Class 3, Japan JIS BS 5295, Class 3, UK	EN-1822 (H14), Europe IEST-RP-CC001.3, USA IEST-RP-CC007, USA IEST-RP-CC034.1, USA	IEC 61010-1, Worldwide EN 61010-1, Europe UL 61010-1, USA CAN / CSA-22.2, No.61010-1

*CFDA certification is exclusive to AB2 models sold in China.

Cabinet Filtration System

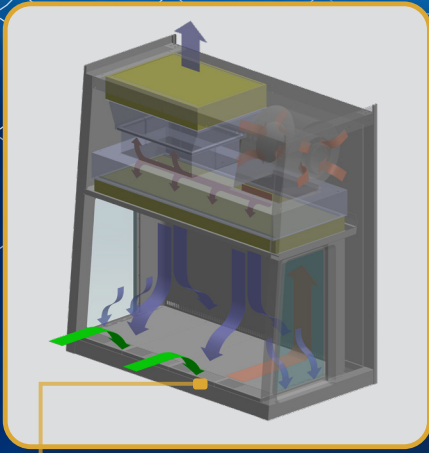

- Ambient air is pulled through front grille to create inflow, without going through the work surface. Inflow is joined by half of the downflow, to create front air curtain that is fine-tuned to create a large performance envelope. The combined air stream travels through the back air column towards the blower.
- Approximately 1/3 of the air in the common plenum is exhausted through the ULPA filter to the room. The remaining 2/3 of the air is passed through the downflow ULPA filter and into the work area as a vertical laminar flow air to create ISO Class 3 work surface and prevents cross contamination.
- Near the work surface, the downflow splits. About Half goes to the front grille, and half goes to the rear grille. A small portion enters the side capture zones to prevent dead air corners (small blue arrows).
- The design was optimized to give large performance envelope, that provides operator and product protection at wide Inflow and Downflow variation from the Nominal point.

Performance Envelope of AC2 G3

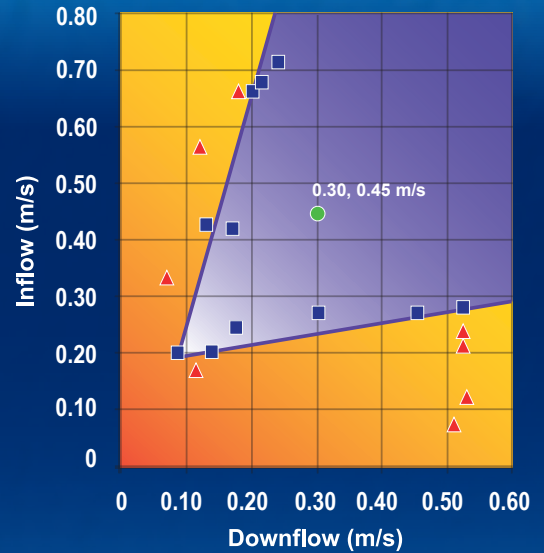

- Nominal Airflow
- Personnel / Product Protection
- Area of Personnel / Product Protection
- ▲ No Personnel / Product Protection
- Area of no Personnel / Product Protection

S1

S7

S7 Dynamic air barrier, where inflow and forward-directed downflow air converge

- ULPA-filtered air
- Unfiltered / potentially contaminated air
- Room air / Inflow air

S21

S3

S16

LCD simultaneously displays time, airflow & sash status, inflow and downflow velocities, and status remarks.

Multi Language: English, French, German, Spanish, Italian.

Diagnostics button, to easily check the cabinet operating parameters and assist servicing.

Large touchpad control buttons provide good tactile feedback.

Color coded LED: green for fan; blue for LED Lamp and outlets; and orange for UV lamp.

Programmable UV light timer extends UV lamp life.

4

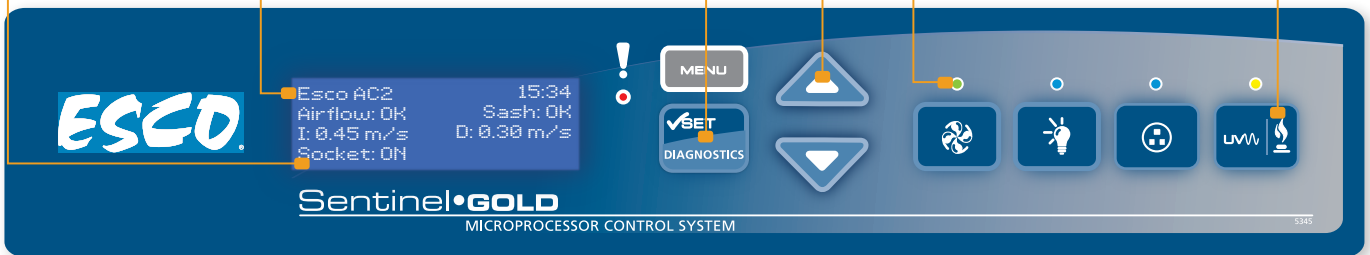

Accessories for AC2-G3 Biological Safety Cabinets

Cabinet	Glass Side Wall	230 VAC, 50/60 Hz	AC2-2E8	AC2-3E8	AC2-4E8	AC2-5E8	AC2-6E8
			2010718	2010658	2010621	2010656	2010657
Cabinet	Stainless Steel Side Wall	115 VAC, 50/60 Hz	AC2-2S8	AC2-3S8	AC2-4S8	AC2-5S8	AC2-6S8
			2010767	2010721	2010711	2010725	2010722
	AC2-2E9		AC2-3E9	AC2-4E9	AC2-5E9	AC2-6E9	
	2010777		2010779	2010697	2010784	2010787	
Exhaust Ducting	Anti-blowback Valve 10"		ABBV-10P 5170352				
	Tri-safe Exhaust Collar with Alarm		N/A	TEM-4 2010606	N/A		
	Thimble Exhaust Collar	ECO-AC22 5170520	ECO-AC23 5170521	ECO-AC24 5170522	ECO-AC25 5170523	ECO-AC26 5170524	
Work Zone	UV Lamp		UV-15A-L 5170251			UV-30A-L 5170255	
	IV Bar	IV-605 5170498	IV-910 5170499	IV-1215 5170231	IV-1520 5170500	IV-1825 5170501	
	Multiple Piece Tray Option (AC2-S / AC2-D)	SDT-AC2-2E 5020643	SDT-AC2-3E 5020635	SDT-AC2-4E 5020606	SDT-AC2-5E 5020640	SDT-AC2-6E 5020592	
	Single Piece Tray Option (AC2-E / AC2-G)	SGT-AC2-2S 5020696	SGT-AC2-3S 5020648	SGT-AC2-4S 5020627	SGT-AC2-5S 5020651	SGT-AC2-6S 5020645	
Electrical Outlet	Pre-filter	PF-40 5090060	PF-41 5090061	PF-42 5090062	PF-43 5090063	PF-44 5090064	
	Direct Mounted / GFCI			EO-			



ABBV-10P



TEM-4

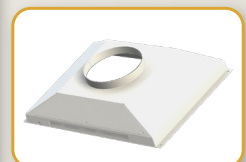

ECO-AC2-G3



IV-

S17

Service Fixtures	EU SF-Gas-20 mm	SF-1G20 5170410				
	EU SF-Vacuum-20 mm	SF-1V20 5170457				
	EU SF-Air-20 mm	SF-1A20 5170502				
	EU SF-Nitrogen-20 mm	SF-1N20 5170503				
	EU SF-Water-20 mm	SF-1W20 5170458				
	EU SF-Universal-22 mm	SF-2U22 5170504				
S4 S6 Support Stands, Ships Flat	Fixed Stand with Leveling Feet, 28" height	SAL-2A0 Gen 2 5130169	SAL-3A0 Gen 2 5130170	SAL-4A0 Gen 2 5130134	SAL-5A0 Gen 2 5130171	SAL-6A0 Gen 2 5130172
	Fixed Stand with Leveling Feet, 34" height	SAL-2B0 Gen 2 5130173	SAL-3B0 Gen 2 5130174	SAL-4B0 Gen 2 5130175	SAL-5B0 Gen 2 5130176	SAL-6B0 Gen 2 5130177
	Fixed Stand with Caster Wheels, 28" height	SPC-2A0 Gen 2 5130161	SPC-3A0 Gen 2 5130155	SPC-4A0 Gen 2 5130152	SPC-5A0 Gen 2 5130162	SPC-6A0 Gen 2 5130154
	Fixed Stand with Caster Wheels, 34" height	SPC-2B0 Gen 2 5130164	SPC-3B0 Gen 2 5130165	SPC-4B0 Gen 2 5130166	SPC-5B0 Gen 2 5130167	SPC-6B0 Gen 2 5130168
	Telescopic Stand with Leveling Feet, 1" adjustment	STL-2A0 5130092	STL-3A0 5130050	STL-4A0 5130051	STL-5A0 5130052	STL-6A0 5130053
	Telescopic Stand with Caster Wheels, 1" adjustment	STC-2A0 5130135	STC-3A0 5130055	STC-4A0 5130056	STC-5A0 5130057	STC-6A0 5130058
	Motorized Height Stand with Caster Wheels, 39.5" height		SPM-3A2 5130093	SPM-4A2 5130047	SPM-5A2 5130100	SPM-6A2 5131141
Misc	IQ/OQ Protocol			9010179		

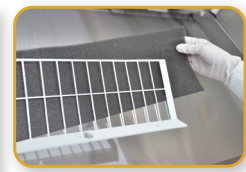

PF-.



ABBV-10P

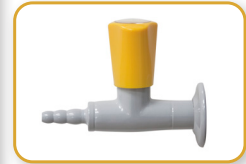

SF-.



SPC-_A0 Gen2

AC2 Biological Safety Cabinet Engineering Drawing

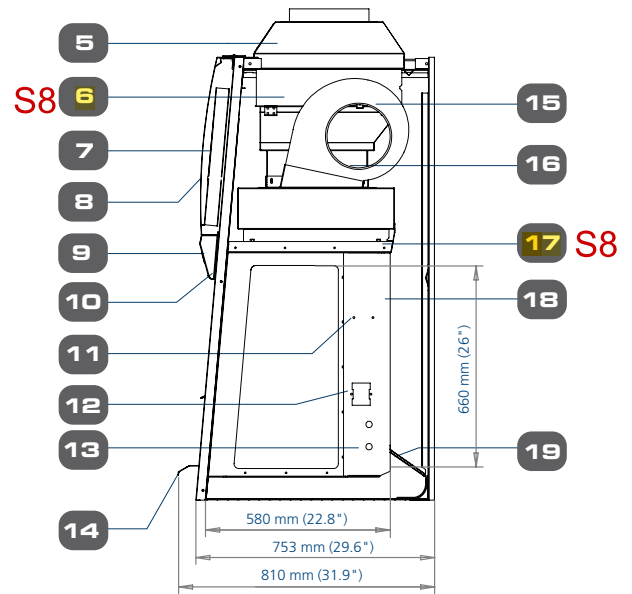
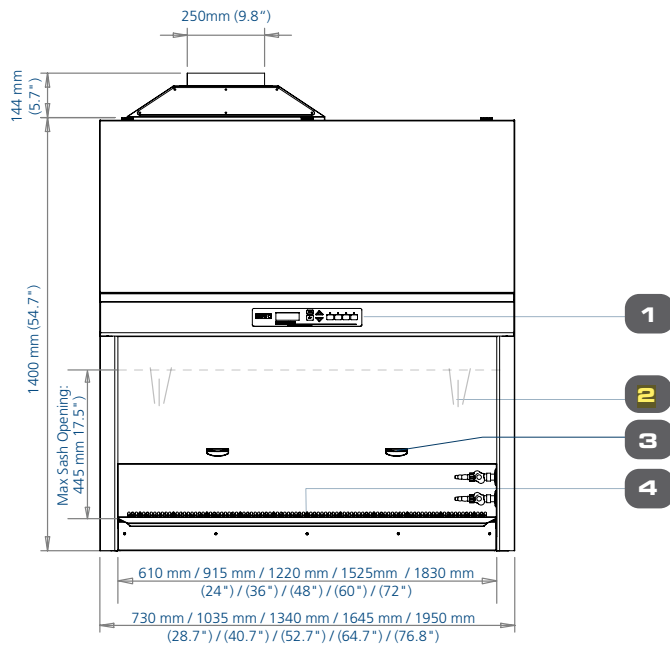

1. Esco Sentinel™ Gold Microprocessor Control System

S13 2. Tempered Glass Sliding Sash Window

3. Ergonomic Sash Handle

S14 4. Stainless Steel Work Tray (available in single and multi pieces)

5. Exhaust Collar (optional)

S8 6. Exhaust ULPA / H14 Filter

7. Electrical Panel

8. Curved Front Panel

9. Angled down LCD and Control Panel

10. LED Lamp

11. IV Bar Retrofit Kit Provision

12. Electrical outlet Retrofit Kit Provision (1 on each side)

13. Service Fixture Retrofit Kit Provision (2 on each side)

14. Ergonomic Dual Posture Stainless Steel Arm Rest

15. DC ECM Blower

16. Second Blower, for exhaust (AC2-D & AC2-G)

S8 17. Downflow ULPA / H14 Filter

S16 18. UV Lamp (optional)

19. Removable Paper Catch (with optional pre-filter)

Optional Exhaust Collar Positions for Thimble-Ducting for AC2 Models

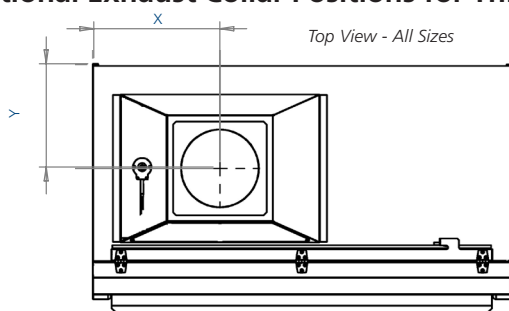

Size	2	3	4	5	6	ft
	0.6	0.9	1.2	1.5	1.8	m
X	233	331	408	560	560	mm
Y	334	334	334	334	326	
X	9.2	13	16	22	22	inches
Y	13.1	13.1	13.1	13.1	12.8	

TECHNICAL SPECIFICATIONS

Glass Side: 230 VAC, 50/60 Hz		AC2-2E8 2010718	AC2-3E8 2010658	AC2-4E8 2010621	AC2-5E8 2010656	AC2-6E8 2010657
Glass Side: 115 VAC, 50/60 Hz		AC2-2E9 2010777	AC2-3E9 2010779	AC2-4E9 2010697	AC2-5E9 2010784	AC2-6E9 2010787
Stainless Steel Side: 230 VAC, 50/60 Hz		AC2-2S8 2010767	AC2-3S8 2010721	AC2-4S8 2010711	AC2-5S8 2010725	AC2-6S8 2010722
Stainless Steel Side: 115 VAC, 50/60 Hz		AC2-2S9 2010790	AC2-3S9 2010792	AC2-4S9 2010744	AC2-5S9 2010797	AC2-6S9 2010800
Nominal Size		2 ft (0.6 meter)	3 ft (0.9 meter)	4 ft (1.2 meter)	5 ft (1.5 meter)	6 ft (1.8 meter)
External Dimensions (W x D x H)	Width	730 mm (28.8")	1035 mm (40.8")	1340 mm (52.8")	1645 mm (64.8")	1950 mm (76.8")
	Depth without Arm Rest	753 mm (29.5")				
	Depth with Arm Rest	810 mm (32.0")				
	Height	1400 mm (54.8")				
Gross Internal Dimensions (W x D x H)	Width	610 mm (24.0")	915 mm (36.0")	1220 mm (48.0")	1525 mm (60.0")	1830 mm (72.0")
	Depth	580 mm (22.8")				
	Height	660 mm (26.0")				
Usable Work Area		0.27 m ² (2.9 sq.ft.)	0.42 m ² (4.5 sq.ft.)	0.56 m ² (6.1 sq.ft.)	0.71 m ² (7.63 sq.ft.)	0.86 m ² (9.2 sq.ft.)
Tested Opening		175 mm (7")				
Work Opening		190 mm (7.5")				
Maximum Opening		475 mm (18.7")				
Average Airflow Velocity	Inflow	0.45 m/s (90 fpm)				
	Downflow	0.30 m/s (60 fpm)				
Airflow Volume	Inflow	173 cmh (102 cfm)	259 cmh (152 cfm)	346 cmh (204 cfm)	432 cmh (254 cfm)	519cmh (305 cfm)
	Downflow	369 cmh (217 cfm)	553 cmh (325 cfm)	738 cmh (434 cfm)	922 cmh (543 cfm)	1107 cmh (657 cfm)
	Exhaust	173 cmh (102 cfm)	259 cmh (152 cfm)	346 cmh (204 cfm)	432 cmh (254 cfm)	519cmh (305 cfm)
	Required Exhaust with Optional Thimble Exhaust Collar	260 m ³ /h (153 cfm)	320 m ³ /h (189 cfm)	538 m ³ /h (317 cfm)	615 m ³ /h (362 cfm)	823 m ³ /h (485 cfm)
	Static Pressure for Optional Thimble Exhaust Collar	28 Pa / 0.11 in H ₂ O	29 Pa / 0.11 in H ₂ O	31 Pa / 0.12 in H ₂ O	35 Pa / 0.14 in H ₂ O	47 Pa / 0.18 in H ₂ O
ULPA Filter Typical Efficiency		>99.999% at 0.1 to 0.3 micron, ULPA as per IEST-RP-CC001.3 USA				
		>99.999% at MPPS, H14 as per EN 1822 EU				
Sound Emission*	NSF / ANSI 49	56.3	56.6	58.7	58.2	59.4
	EN 12469	51.0	52.0	53.5	53.6	55.7
LED Lamp, Light intensity		1000 lux (93 ft.cd)				
Cabinet Construction	Main body	1.2 mm (0.05") 18 gauge electro-galvanized steel with white oven-baked epoxy-polyester Isocide™ antimicrobial powder-coated finish				
	Work Zone	1.5 mm (0.06") 16 gauge stainless steel, type 304, with 4B finish				
	Side Walls (E Series)	UV-absorbing tempered glass, 5 mm (0.2"), colorless and transparent				
	Side Walls (S Series)	1.5 mm (0.06") 16 gauge stainless steel, type 304, with 4B finish				
Electrical	Cabinet Full Load Amps (FLA)	1.8 A7	3.5 A	3.7 A	4.3 A	5.5 A
	Optional Outlets (FLA)	5 A				
	Heat Load (BTU/Hr)	324	447	580	717	966
Nominal Power Consumption (W)		87.6	133	167	211	271
Net Weight**		116 Kg (256 lbs)	173 Kg (381 lbs)	230 Kg (507 lbs)	288 Kg (635 lbs)	346 Kg (763 lbs)
Shipping Weight**		143 Kg (315 lbs)	214 Kg (472 lbs)	285 Kg (628 lbs)	356 Kg (785 lbs)	428 Kg (944 lbs)
Shipping Dimensions Maximum (W x D x H)**		850 x 820 x 1760 mm (33.5" x 32.3" x 69.3")	1120 x 820 x 1760 mm (44.1" x 32.3" x 69.3")	1450 x 820 x 1760 mm (57.1" x 32.3" x 69.3")	1720 x 820 x 1760 mm (67.7" x 32.3" x 69.3")	2050 x 820 x 1760 mm (80.7" x 32.3" x 69.3")
Shipping Volume, Maximum**		1.23 m ³ (43.2 ft ³)	1.62 m ³ (57.2 ft ³)	2.09 m ³ (73.8 ft ³)	2.48 m ³ (87.6 ft ³)	2.96 m ³ (104.5 ft ³)

*Noise reading in open field condition / anechoic chamber. Noise reading in normal room varies by room size, layout, and background noise, but may reach roughly 3-4 dBA above these values.
 **Cabinet only, excludes optional stand.

TECHNICAL SPECIFICATIONS

Glass Side: 230 VAC, 50/60 Hz		AC2-4G8 2010734	AC2-6G8 2010743
Stainless Steel Side: 230 VAC, 50/60 Hz		AC2-4D8 2010733	AC2-6D8 2010742
Nominal Size		4 ft (1.2 meter)	6 ft (1.8 meter)
External Dimensions (W x D x H)	Width	1340 mm (52.8")	1950 mm (76.8")
	Depth without Arm Rest	753 mm (29.5")	
	Depth with Arm Rest	810 mm (32.0")	
	Height	1400 mm (54.8")	
Gross Internal Dimensions (W x D x H)	Width	1220 mm (48")	1830 mm (72")
	Depth	580 mm (22.8")	
	Height	660 mm (26")	
Usable Work Area		0.56 m ² (6.1 sq.ft.)	0.86 m ² (9.0 sq.ft.)
Tested Opening		175 mm (7")	
Working Opening		190 mm (7.5")	
Average Airflow Velocity	Inflow	0.45 m/s (90 fpm)	
	Downflow	0.30 m/s (60 fpm)	
Airflow Volume	Inflow	346 cmh (588 cfm)	519 cmh (881 cfm)
	Downflow	738 cmh (1254 cfm)	1107 cmh (1880 cfm)
	Exhaust	346 cmh (588 cfm)	519 cmh (881 cfm)
	Required Exhaust with Optional Thimble Exhaust Collar	538 m ³ /h (317 cfm)	823 m ³ /h (485 cfm)
	Static Pressure for Optional Thimble Exhaust Collar	31 Pa / 0.12 in H ₂ O	47 Pa / 0.18 in H ₂ O
ULPA Filter Typical Efficiency		>99.999% at 0.1 to 0.3 micron, ULPA as per IEST-RP-CC001.3 USA >99.999% at MPPS, H14 as per EN 1822 EU	
Sound Emission*	NSF / ANSI 49	61.3 dBA	62.5 dBA
	EN 12469	58.3 dBA	59.5 dBA
LED Lamp Intensity (Lux)		1400	
LED Lamp Intensity (foot-candles)		130	
Cabinet Construction	Main body	1.2 mm (0.05") 18 gauge electro-galvanized steel with white oven-baked epoxy-polyester Isocide™ antimicrobial powder-coated finish	
	Work Zone	1.5 mm (0.06") 16 gauge stainless steel, type 304, with 4B finish	
	Side Walls (G-Series)	UV-absorbing tempered glass, 5 mm (0.2"), colorless and transparent	
	Side Walls (D-Series)	1.5 mm (0.06") 16 gauge stainless steel, type 304, with 4B finish	
Electrical	Cabinet Full Load Amps (FLA)	9.4 A	12.6 A
	Optional Outlets (FLA)	5 A	
	Heat Load (BTU / Hr)	905	1230
Nominal Power Consumption (W)		197	293
Net Weight**		240 Kg (529 lbs)	366 Kg (807 lbs)
Shipping Weight**		295 Kg (650 lbs)	448 Kg (988 lbs)
Shipping Dimensions, Maximum (W x D x H)**		1450 x 820 x 1760 mm (57.1" x 32.3" x 69.3")	2050 x 820 x 1760 mm (80.7" x 32.3" x 69.3")
Shipping Volume, Maximum**		2.09 m ³ (73.8 ft ³)	2.96 m ³ (104.5 ft ³)

*Noise reading in open field condition / anechoic chamber. Noise reading in normal room varies by room size, layout, and background noise, but may reach roughly 3-4 dBA above these values.

**Cabinet only, excludes optional stand.

First Airstream® Offers the Most Complete Class II Cabinet Range

Airstream Product	E-Series	G-Series	S-Series	D-Series
Side Wall	Tempered glass increases visibility and prevents the operator from experiencing a "boxed-in" feeling S12		One-piece stainless steel with coved corners for cleanability. Side capture zones and negative pressure side walls optimize containment.	
Work Tray	S14 Multi-piece, Autoclavable		Single-piece stainless steel, spill retaining	
Fan System	Single blower for inflow and downflow. Energy-efficient and cost-effective	Dual blowers for inflow and downflow. Redundant system provides protection in case of fan failure.	Single blower for inflow and downflow. Energy-efficient and cost-effective.	Dual blowers for inflow and downflow. Redundant system provides protection in case of fan failure.
Exhaust Filter	Single, cost-effective ULPA/H14 filter with > 99.999% efficiency	Dual ULPA/H14 filters that provide >100x better protection than single filter system	Single, cost-effective ULPA/H14 filter with >99.999% efficiency	Dual ULPA/H14 filters that provide >100x better protection than single filter system
Size Available	0.6 m (2'), 0.9 m (3'), 1.2 m (4'), 1.5 m (5'), 1.8 m (6')	1.2 m (4'), 1.8 m (6')	0.6 m (2'), 0.9 m (3'), 1.2 m (4'), 1.5 m (5'), 1.8 m (6')	1.2 m (4'), 1.8 m (6')

AC2-D Airflow Diagram

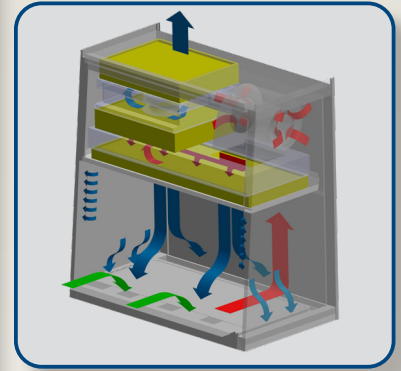

- ULPA-filtered air
- Unfiltered / potentially contaminated air
- Room air / Inflow air

AC2-G Airflow Diagram

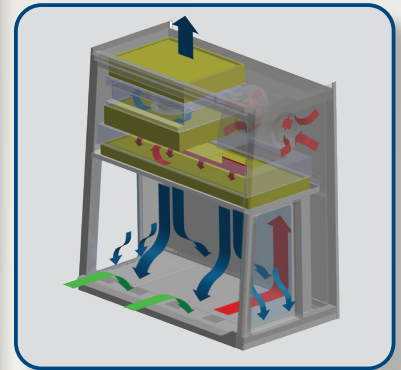

- ULPA-filtered air
- Unfiltered / potentially contaminated air
- Room air / Inflow air

7

Comprehensive Performance Testing At Esco

Every Airstream® AC2 model manufactured by Esco is individually tested, documented by serial number and validated with the following test methods:

- Inflow and downflow velocity
- PAO aerosol challenge for filter integrity
- Airflow pattern visualization
- Electrical safety to IEC61010-1
- Additional KI-Discus containment and microbiological testing are performed on statistical sampling basis.



ESCO LIFESCIENCES GROUP
42 LOCATIONS IN 21 COUNTRIES ALL OVER THE WORLD

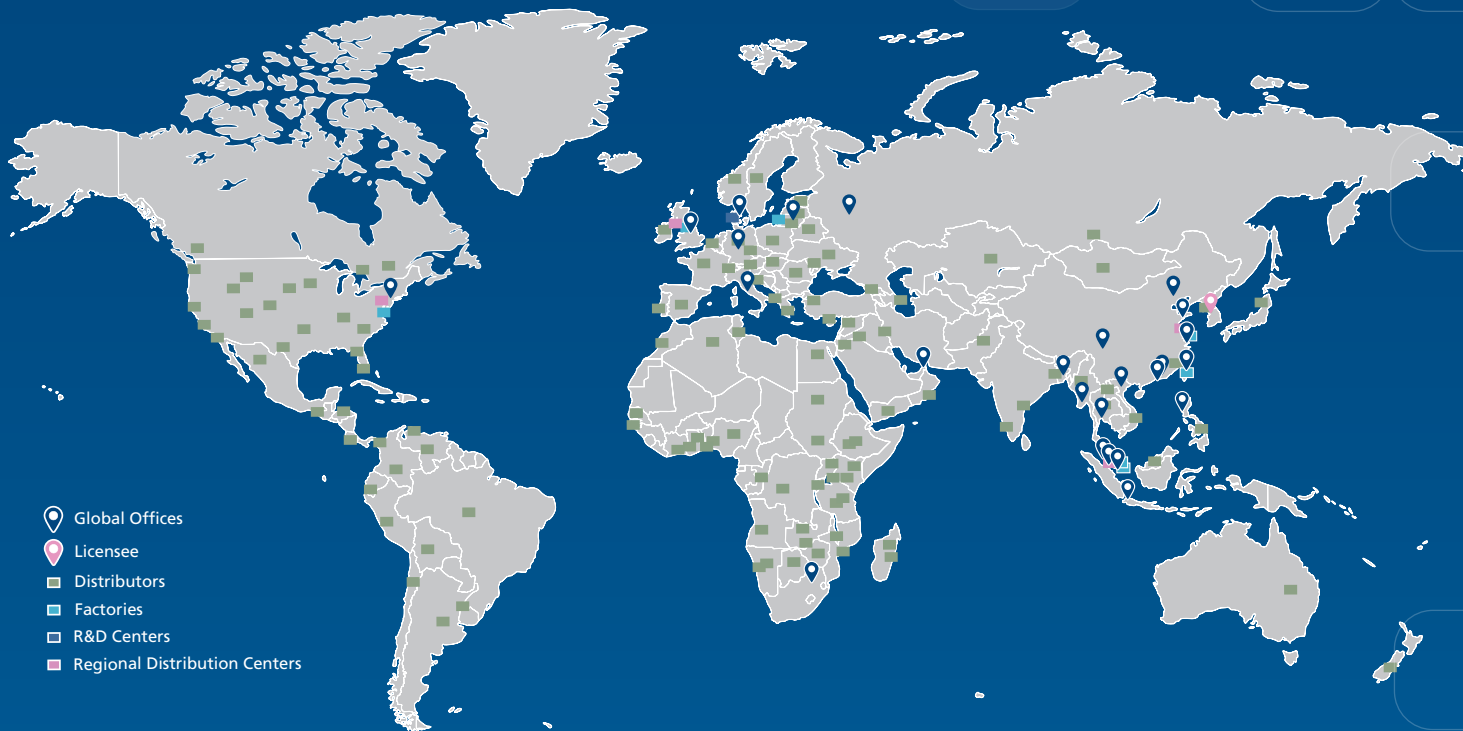

-  Global Offices
-  Licensee
-  Distributors
-  Factories
-  R&D Centers
-  Regional Distribution Centers

*Follow us on social media, download our apps,
and scan the QR code for more info.*



@EscoLifesciences



@EscoLifesciences



@EscoLifesci



@Esco



@EscoLifesciences



@EscoLifesciences



Esco Lifesciences



Esco Lifesciences

ESCO[®]
LIFESCIENCES GROUP

Esco Micro Pte. Ltd. • 19 Changi South Street 1 • Singapore 486 777
Tel +65 6542 0833 • mail@escolifesciences.com
www.escolifesciences.com

Esco Technologies, Inc. • 903 Sheehy Drive, Suite F, Horsham, PA 19044, USA
Tel: +1 215-441-9661 • eti.admin@escolifesciences.com



Esco Lifesciences Group Offices: Bangladesh | China | Denmark | Germany | Hong Kong | India | Indonesia | Italy | Japan | Lithuania | Malaysia | Myanmar | Philippines | Russia | Singapore | South Africa | South Korea | Taiwan | Thailand | UAE | UK | USA | Vietnam