



PUBELA 120L PREMIUM

120L PREMIUM WASTE BIN

Fișa tehnică / Technical data

Categorie Category	Detalii Details
COD Produs Product Code	<ul style="list-style-type: none">● P120PA● P120PR● P120PG● P120PV● P120PM● P120PN
Dimensiune - L x l x H Dimension - W x D x H	● 480 x 470 x 950 mm
Volum nominal Nominal volume	● 120 L
Greutate Weight	● 8,5 KG
Masă Totală Admisă Max. Permissible Weight	● 60 KG
Sistem de rulare Wheel assembly	● Roți HDPE 200 mm (D200mm) 200 mm HDPE wheels (D200mm)
Ax roți Wheel axle	● Ax din oțel Steel axle
Ambalare Packing	● SUPRAPUSE / VRAC Stacked / Bulk
Culori Standard Standard Colors	● 
Tip produs Product Type	● Pubelă / Recipient mobil pentru deșeuri Mobile waste container
Material Material	● HDPE
Închidere Closure	● Capac cu balamale Flat Hinged Lid
Elemente incluse Included elements	● 2x Roți / 1x Tijă Metalică / 2x Capac de prindere 2x Wheels / 1x Metal Axle / 2x Locking Caps
Standarde și Certificări Standards and Certifications	● EN 840-1:2020 EN 840-5:2020 EN 840-6:2020 RAL-GZ 951/1/08.23 AfPS GS 2019:01 PAK
Certificare Certification	● TÜV Rheinland (Geprüfte Sicherheit)

Produsul Sterk Plast este conceput pentru colectarea materialelor reciclabile și a deșeurilor menajere.

Sterk Plast S.R.L., Str. Constanței nr. 2, 905600 Medgidia, România

www.sterkplast.com | office@sterkplast.ro

PUBELA 120L PREMIUM

Fișa tehnică / Technical data

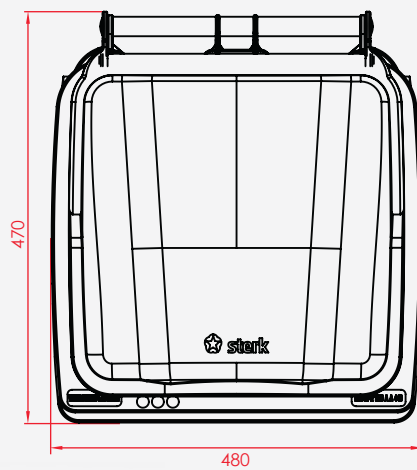
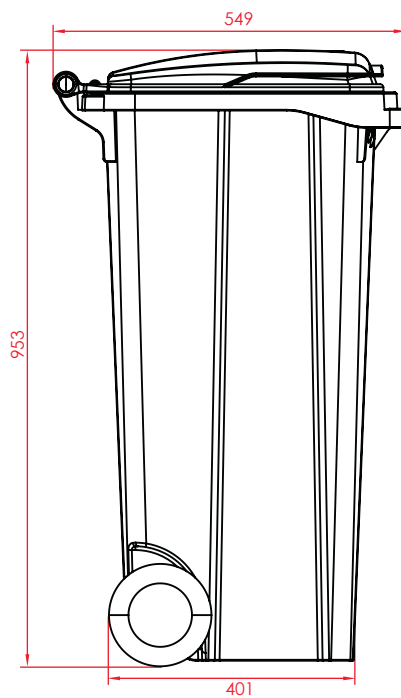
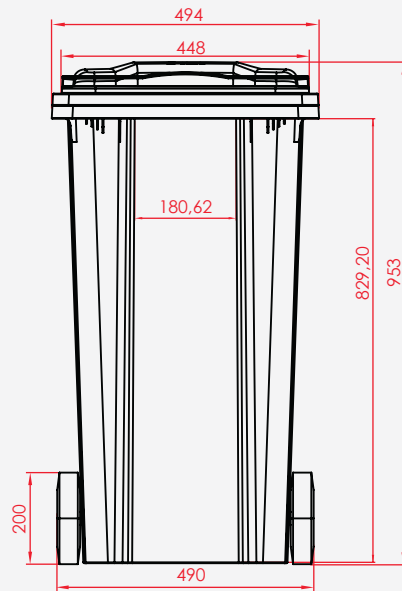

sterkplast®