

TOUCH II

User friendly and totally programmable microprocessor with 7" touch screen.
 USB Connection: Online platform free of charge for programming, telemetry, data analysis...thanks to the IoT.
 Videos on display: ads, instructions (useful for coin laundry).
 37 languages.
 8 dosing signals as standard + optional 6 extra dosing signals.

G FACTOR

High G FACTOR 500 (11 - 18 kg), 450 (22 - 80 kg) and 350 (100C - 120C).
 It reduces the residual moisture.

EFFICIENCY

Optimal loading: manual indication of weight.
 Intelligent consumption: automatic adjustment of water and soap consumptions (standard).
 Water Recovery tanks ready: **ECOTANK** and **ECOTANK XL**.
 Low water consumption.

VERSATILITY

Make to order: customisation.
 OPL < > COIN (mod. DHS-11 up to DHS-45C).
 Electric < > Hot water.
 Drain valve < > Pump (DHS-11/14).
 Wet Cleaning features.

CONNECTIVITY

IoT - **DOMUSCONNECT** standard.
 Remote technical service.
 Management for laundries: OPL and COIN.
 Remote payment DOMUS LAUNDRY App (mod. DHS-11 up to DHS-45C).

ERGONOMICS

Easy opening/closing system for door lock.
 Biggest door diameters:
 • Ø 373 (11, 14 kg)
 • Ø 460 (18, 22, 28 kg)
 • Ø 560 (35, 45, 60, 80 kg)
 • Ø 700 (100, 120 kg)

MAINTENANCE

Hinged control panel: easy and ergonomic access.
 Technical menu: statistics for technicians.

OTHERS

Grey skinplate outer casing.
 Drum and vat in stainless steel AISI 304.
 Detergent dispenser with 4 compartments.
 Electronic control of imbalance with frequency control.
 LOADING AID feature: water and rotation control.
 Soft mounted washers, free standing.
 CB and WRAS approved product. Option ETL.
 REG4 standard certified by KIWA.



OPTIONS

- License IoT - DOMUSCONNECT
- Ready for ECOTANK conn. 3/4" for washers DLS/DHS-11/14/18/22/28
- DOSING PUMP KIT DQ-2
- EXTRA DOSING PUMP DB-1
- Double drain kit for DHS-14/18/22
- Normally closed valve DHS-18/22
- WATER RE-CYCLE: recirculation of bath water DHS-18. Not with ECOTANK
- Leveling feet for DHS-11 to DHS-28
- Weighing sensor system on feet for DHS-11 to DHS-45C. Includes kit 6 extra dosing signals
- 6 extra dosing signals card for DHS-11 to DHS-45C. Total of 14 signals
- Silicon gasket DHS-18/22/28
- Reversible door: reverse door opening
- Kit to transform an E or HW DHS-11/14/18/22 to steam
- Plinth for mops with drawer DHS-18/22 stainless steel
- Plinth for mops with drawer DHS-18/22 SKINPLATE
- Stainless steel plinth for DHS-18/22 to level all machines from top
- Skinplate plinth for DHS-18/22 to level all machines from top
- Stainless steel plinth for DHS-18/22 to align the doorbase at 850 mm
- Skinplate plinth for DHS-18/22 to align the doorbase at 850 mm
- Stainless steel AISI 304 outer casing for DHS-18
- Stainless steel AISI 304 front and top panel for DHS-18
- Auto unlock kit for the door (in case of power failure) DLS-DHS
- 440V III No N 50/60Hz for DHS-18/22 (maritime)
- Several payment systems for self-service

DRUM	UNIT.	DHS-18 TOUCH II	
Capacity 1/9	Kg	20	
Capacity 1/10	Kg	18	
Volume	l	180	
Diameter	mm	700	
Depth	mm	470	
GENERAL DETAILS			
Washing speed / Spining speed	r.p.m.	47 / 1.133	
G Factor	-	500	
Maximum force transmitted	KN	3,41 ±1,4	
Frequency-dynamic force	Hz	16	
Noise level	dB	< 70	
Coin laundry version	-	YES	
Double drain	-	OPT.	
Weighing system / Tilting door	-	OPT./NO	
SLUICE option	-	NO	
DOOR			
Height center door / Height door	mm	765 / 450	
Diameter	mm	460	
POWER			
Motor	kW	2,2	
Electric heating power	kW	15	
Total electric power (electric model)	kW	17,75	
CONNECTIONS		E	HW/S
Tension 110V - I + N + T	Nº x mm² / A	-	-
Tension 230V - I + N + T	Nº x mm² / A	2x16+T - 63A	2x1,5+T - 16A
Tension 230V - III + T	Nº x mm² / A	3X6+T - 40A	-
Tension 400V - III + N + T	Nº x mm² / A	4x4+T - 32A	-
Steam inlet (Steam model)	inch	1/2"	1/2"
Maximum steam consumption (Steam model)	Kg/h	12	
Water inlet	inch	3/4"	
Water main pressuer	Kgs/cm²	2-4	
Maximum water consumption*	Lit/h	118,3*	
Air inlet	Kg/cm²	-	
Drain	mm/inch	3"	
Drainage capacity	Lit/min	200	
DIMENSIONS / PACKING DIMENSIONS			
Net Width/Gross width	mm	884 / 945	
Net Depth/Gross depth	mm	913 / 1.030	
Net Height / Gross height	mm	1.405 / 1.680	
Net weight / Gross weight	kg	344,5 / 388	
Volume	m³	1,63	

* Program No. 20: DLS-11 to DLS-45C with 75% load and program no. 2: DLS-60C and DLS-80C with 100% load

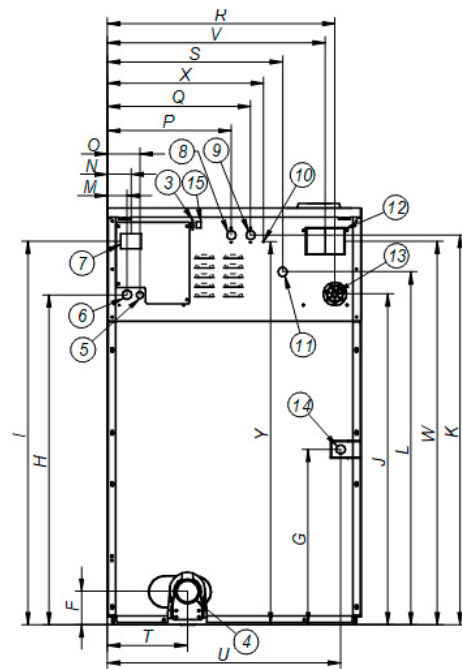
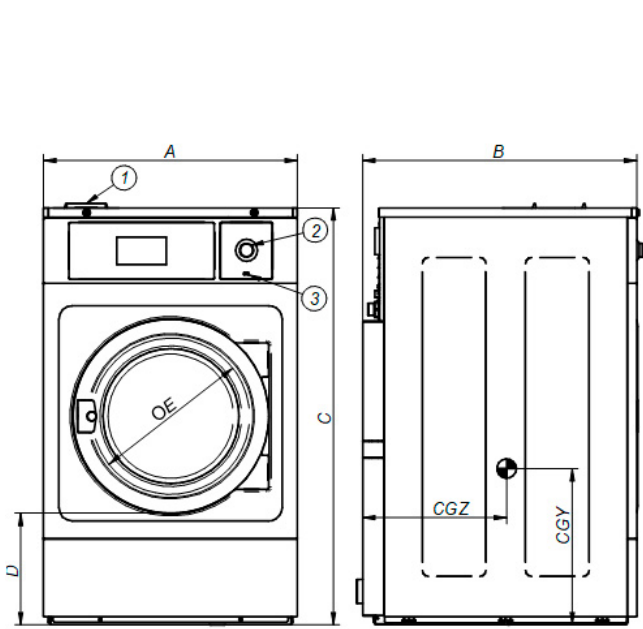

1. Soap dispenser
2. Emergency stop
3. USB port
4. Drain
5. Electric connection to liquid soap pumps
6. Electrical connection
7. Main switch
8. Auxiliar water inlet
9. Hot water inlet
10. Equipotential connection
11. Cold water inlet
12. Blur output / Water overload
13. Liquid soap connection
14. Steam connection
15. Ethernet port

DHS-18		A	B	C	D	E	F	G	H	I	J	K	L	M	N	O	P	Q	R	S	T	U	V	W	X	Y	CGY	CGZ
	mm	884	913	1.405	450	460	125	380	1.135	1.303	1.138	1.322	1.207	61	74	101	429	509	802	640	322	814	772	1.303	569	1.297	464	702
	inch	34,80	35,94	55,31	17,72	18,11	4,92	14,96	44,68	51,30	44,80	52,05	47,52	2,40	2,91	3,98	16,89	20,04	31,57	25,20	12,68	32,05	30,39	51,30	22,40	51,06	18,27	27,64