

## S3ESL1 Probe Instruction Manual Specification

MN1-6111 Rev.6

*Notes for operators and responsible maintenance personnel*

- ★ *Please read through this Instruction Manual as well as the separate Instruction Manual “Safety (MN1-6105)” and “Cleaning, Disinfection and Sterilization (MN1-6117)” carefully prior to use.*
- ★ *Keep this Instruction Manual together with the ultrasound diagnostic instrument for any future reference.*

**FUJIFILM Healthcare Corporation**



## Introduction

This is the instruction manual for S3ESL1 probe. The probe is available by connecting to our company's ultrasound diagnostic instrument and can be mainly used for observations of the heart.

Prior to use, read this manual as well as the separate instruction manual "Safety" in which information for safe use is provided.

The probe bears the CE mark but the mark is valid only when the probe is connected to the ultrasound diagnostic instrument bearing the CE mark.

## Symbols used in this document

Safety information is classified into Danger, Warning, Caution, and Note according to the level of hazard. Those terms are used in safety information provided to prevent hazards and injuries to the operator or patient.

### Danger

Indicates an imminently hazardous situation which, if not avoided, will result in death or serious injury to the operator or patient.

### Warning

Indicates a potentially hazardous situation which, if not avoided, could result in death or serious injury to the operator or patient.

### Caution

Indicates a potentially hazardous situation which, if not avoided, may result in minor or moderate injury to the operator or patient, or property damage only.

### Note

Indicates a strong request concerning an item that must be observed in order to prevent damage or deterioration of the equipment and also to ensure that it is used efficiently.

The type of safety information is indicated by the symbols below.



This symbol means that attention is required.



This symbol means that the described action is prohibited.



This symbol means that the described action is mandatory.

# CONTENTS

1. General Information.....	1
1-1. Intended use.....	1
1-2. Classification of ME equipment.....	1
1-3. Standard components .....	1
1-4. Options .....	1
2. Specifications and Parts name.....	3
2-1. Specifications.....	3
2-2. Specifications of the bite block.....	4
2-3. Transducer cover .....	4
2-4. Name of each parts .....	5
3. Preparations before use .....	7
3-1. Visual check .....	7
3-2. Deflection portion operation check .....	7
3-3. Transducer rotation part operation check .....	7
3-4. Confirmation of cleaning, disinfection, and sterilization .....	7
3-5. Operation check .....	7
4. Operation.....	9
4-1. Operation of the bite block.....	9
4-2. Transducer cover usage precautions .....	9
4-3. Insertion of Probe .....	10
4-4. Manipulation of Probe .....	11
4-5. Manipulation of the deflection portion .....	13
4-6. Manipulation of the transducer rotation .....	13
4-7. Manipulation of the lock lever .....	14
4-8. Removing the insertion portion.....	14
4-9. Removal of transducer cover .....	14

This instruction manual contains 4 pages of front matter and 16 pages of the main content.

## 1. General Information



General information for the probe is provided below.

### 1-1. Intended use

This probe is intended for use by a doctor when inserted into the patient’s esophagus and its tip contacts the esophageal wall making ultrasonic observations of the heart.

Please refer to the ultrasound diagnostic instrument instruction manual used with this probe for the probe intended use information.

Regarding with the connectable instrument, please refer to section 2-1. Specifications of this manual.

 <b>Warning</b>	
	Do not use this equipment for other than its intended use. Otherwise it could cause burns or other injuries to the operator or the patient.

### 1-2. Classification of ME equipment

This probe is classified as follows according to IEC60601-1.

Please refer to the section 2-1 for the applied part, the part treated as the applied part, and the range of IPX7.

- Classification based on the degree of protection against electric shock ..... Type BF applied part
- Classification for protection against ingress of liquids ..... IPX7 (Watertight equipment)
- Operation mode..... Continuous operation
- Method of sterilization..... Refer to the separate instruction manual “Cleaning, Disinfection and Sterilization”

### 1-3. Standard components

The standard components of S3ESL1 probe are as follows.

- S3ESL1 Probe ..... 1 set
- Bite block SP-7901 ..... 2 set
- Storage case ..... 1 set
- Instruction Manual
  - Specification (MN1-6111) ..... 1 copy
  - Safety (MN1-6105) ..... 1 copy
  - Cleaning, Disinfection and Sterilization (MN1-6117) ..... 1 copy

### 1-4. Options

The following options are available for this probe.

- Reprocessing by liquid detergent, disinfectant or sterilant  
Whole the probe is able to immerge into the liquids by putting the connector of the ultrasound probe to the waterproof case WP-001 as below table 1  
Precautions about the waterproof case, please refer to the instruction manual.

Table 1 Accessory for reprocessing by liquid detergent, disinfectant or sterilant

Product Name	Product No.
Waterproof case	WP-001



## 2. Specifications and Parts name

The specifications and the name of each part are provided below.

### 2-1. Specifications

Application:	Heart and thoracic aorta
Type of patient contact:	Transesophageal
Connectable instruments:	ARIETTA 70, ARIETTA 60, Noblus, ALOKA ARIETTA 850, ALOKA LISENDO 880
	NOTE:
	At the time of publication of this manual, the connectable diagnostic ultrasound instrument or instrument software version available with this probe is different for each country, please refer to the instrument instruction manual or contact your local our company representative.
Field of view:	90°
Scan direction	Any direction in ±90° relative to insertion direction of insertion portion
Range of deflection	Up 90° down 60°
Insertion portion diameter	φ9
Insertion portion length	1017mm
Frequency:	5.0 MHz±20%
Cable length:	2100mm
weight	900g
Service life:	3 years
Applied part:	See Figure 1
Part treated as Applied part:	See Figure 1
IPX7 range:	See Figure 1 (In case that not putting the waterproof case to the ultrasound probe connector) In case that putting the waterproof case to the ultrasound probe to the connector, whole the probe from the tip of the ultrasound probe to the connector with Waterproof Case WP-001 is IPX7. range
External dimensions:	See Figure 1

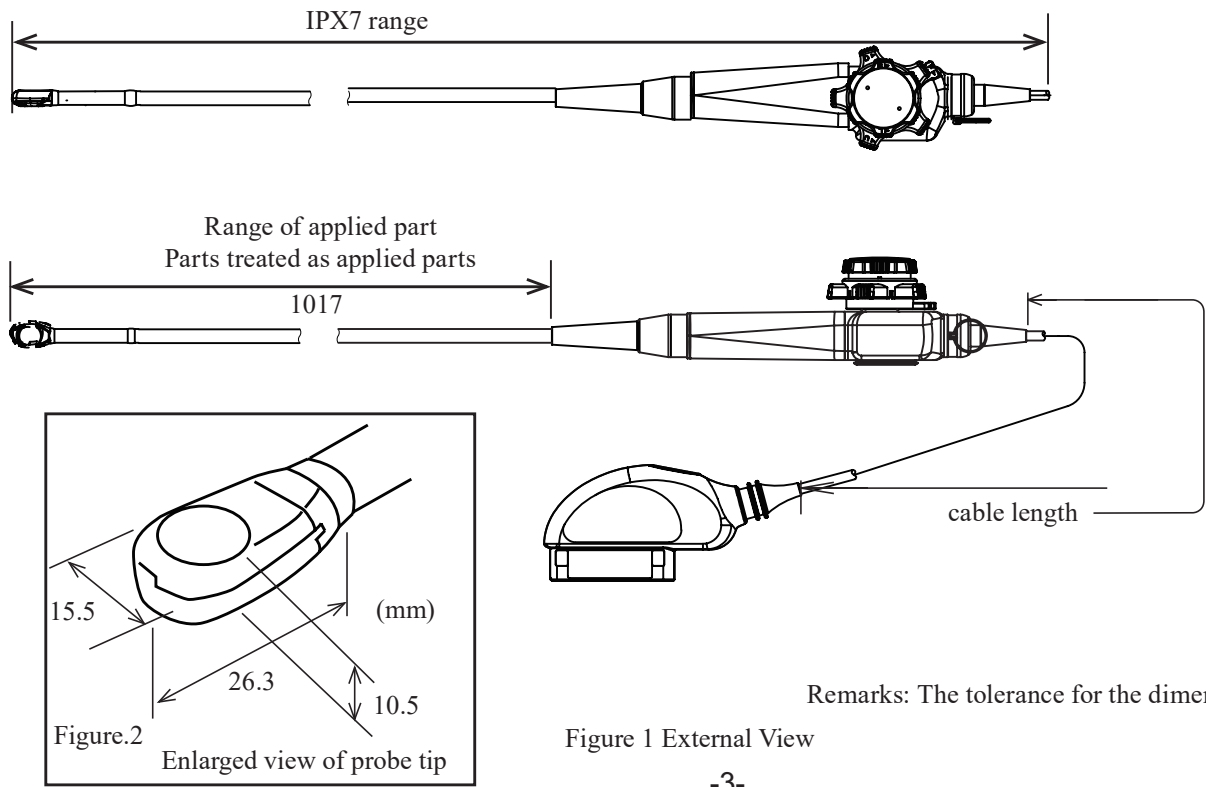

2-2.Specifications of the bite block

Material Polyetherimide  
Service life Three years

External dimensions As shown in the figure below.

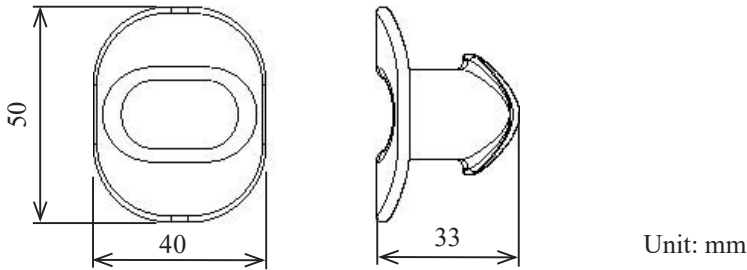

Remarks: The tolerance for the dimensions is  $\pm 10\%$ .

Figure 3 External view of the bite block

2-3. Transducer cover

Use by covering the transducer cover over the insertion portion.

Transducer cover CIVCO Transducer cover 610-933

Remarks

The transducer cover is not included this probe-kit.

2-4. Name of each parts

The name of each part is shown in Figure 4 and the explanation for each part is listed in Table 2.

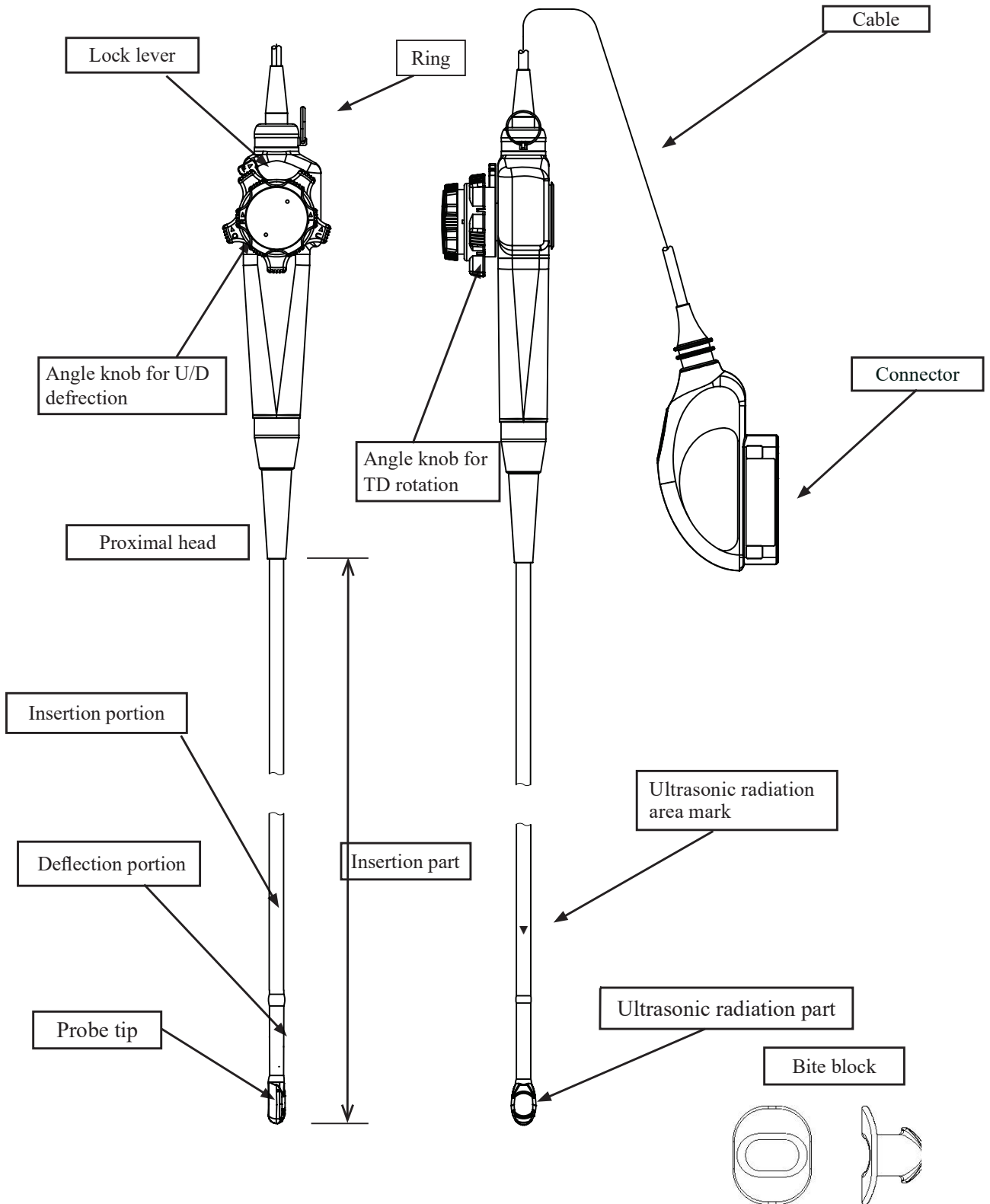

Figure 4 Name of each parts

Table 2 Name of each part and its explanation

Name	Explanation
Ultrasonic radiation part	Ultrasound is radiated from this part. The electronic Sector transducer is integrated underneath this part.
Deflection portion	Operating the angle knob allows this part to be bent UP/DOWN direction
Insertion portion	The probe is inserted into the patient's body up to this section.
Ultrasonic radiation area mark	▼ mark side corresponds to the ultrasonic radiation area.
Angle knob for U/D deflection	This part is used to UP/DOWN operate the deflection portion.
Angle knob for TD rotation	This part is used to Transducer rotation.
Lock lever	This part make the angle knob for U/D deflection fixed any direction.
Proximal head	When using the probe, hold this part by hand.
Cable	Cable transfers electric input/output signals.
Connector	The connector is the part which is connected to the ultrasound diagnostic instrument.
Ring	This part is used for hanging the proximal head
Bite block	This is put in patient's mouth so that keep the path of the probe inserted into the body

⚠ Caution	
⊘	Do not pull, bend, twist, or apply excessive force to the cable. The probe may malfunction due to cable disconnection.
⊘	Do not subject the ultrasonic radiation part to hard impact. The impact may cause damage to the transducer, and that results in noise or no echo in the image. In most cases, the ultrasonic radiation part itself is not damaged because the part is made of plastic material.
⊘	Do not bend or twist the deflection portion unnecessarily or manually . This could make the probe unusable.
⚠	Keep the angle knob in the free position during an operation of curving. Operating the probe while locked, it may become unusable.
⊘	There is no mark to indicate front direction of probe. It becomes right axis angle operation, turn the angle knob to counterclockwis See section 4-6.

Remarks

According to the property of a acoustic medium which filled a tip ,the change of color may be seen in menbrane  
But there is no influence on the performance and safety of the probe.

### 3. Preparations before use

This chapter describes preparations needed to use the probe safely. Please prepare the probe prior to each use by following the instructions below.

#### 3-1. Visual check

Visually and tactually make certain that any of the following abnormalities has not taken place:

Insertion portion is free from holes, dents, scratches, cracks, deformations, color changes and the like on the surface.

Also there is no leakage of the oil inside the transducer.

Manipulate the deflection portion using the angle knob and check for any protrusions or cracks in this area.

Lightly grip insertion portion and deflection portion by hand and let it slide. Then, it shall neither catch your hand on the way nor shall it be slack.

Make sure that all surfaces of the probe connector, cable and proximal head are free of scratches, cracks or exfoliation.

Bite block is free from holes, dents, scratches, cracks, deformations, color changes and the like on the surface.

Transducer cover is free from holes, dents, scratches, cracks, deformations, color changes and the like on the surface.

#### 3-2. Deflection portion operation check

Gently turn the angle knob in each direction until it stops and check the following:

- \* Make sure there are no catching or irregularities in force to turn the angle knob.

- \* Make sure the deflection portion is bent smoothly in all directions.

Operate the lock lever to make sure there are no abnormalities in the curvature holding or releasing functions.

#### 3-3. Transducer rotation part operation check

- Turn the angle knob in each direction of the transducer as far as it will go, and confirm the following.

- \* Make sure the transducer rotates smoothly in all directions.

#### 3-4. Confirmation of cleaning, disinfection, and sterilization

Confirm that the probe is certainly cleaned, disinfected, and sterilized. The degree of reprocessing depends on the intended use. Please refer to the separate instruction manual "Cleaning, Disinfection and Sterilization" for cleaning, disinfection, and sterilization procedure.

#### 3-5. Operation check

Connect the probe to the ultrasound diagnostic instrument and check that the displayed scan type and frequency correspond to those of the probe. Check also that there is no abnormality in the image.

Remark: Please refer to the documentation supplied with the ultrasound diagnostic instrument for how to connect the probe and information displayed on the monitor.

If the probe is operated in still air, brightness on the top of the image may be non uniform, but this does not affect the performance of the probe.

#### Warning

Make preparations prior to each use.



The operator and the patient may be injured if the equipment has any abnormality.

If any abnormality is found in the equipment, stop using it and contact our company written on the back cover.

#### Caution



Do not use the probe if the displayed scan type and frequency do not correspond to those of the probe.

Incorrect acoustic output can result in burns or other injuries to the patient. Contact our company written on the back cover.



4. Operation

This chapter describes the operation of the probe.

4-1. Operation of the bite block

Put this in patient's mouth so that keep the path of the probe inserted into the body

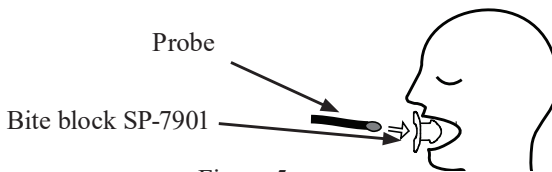

Figure 5

<b>⚠ Warning</b>	
<b>!</b>	Use the bite block supplied with the probe. If the probe is bitten, the probe may be damaged and a hazard to the patient will occur.

4-2. Transducer cover usage precautions

Inside of transducer cover, use the sterilized ultrasound gel which is attached transducer cover

Sterilized echo ultrasound gel which is attached transducer cover

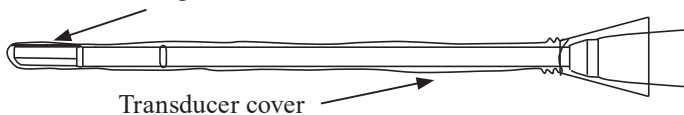

















Figure 6

<b>⚠ Warning</b>	
<b>!</b>	Use the transducer cover over the insertion portion as necessary . Use our company transducer cover .
<b>!</b>	Use our company transducer cover only. If use transducer cover which not reccomended can cause an adverse reaction by the body of the patient..
<b>!</b>	Check that the transducer cover is sterilized. Use of an infected item could spread infection to the patient.
<b>!</b>	Inside of transducer cover, use the sterilized ultrasound gel which is attached transducer cover If use echo jerry which not reccomended by instruction manual, it is cause to deterioration.probe surface.
<b>⊘</b>	Do not reuse the transducer cover . Use of an infected item could spread infection to the patient.
<b>⊘</b>	Do not apply unsterilized acoustic medium to the outer surface of the transducer cover . Use of an acoustic medium that is contaminated by a pathogen can cause an infection on the patient.

<b>⚠ Caution</b>	
<b>!</b>	Check the transducer cover for abnormalities before use. Regarding the storage of the transducer cover, follow the instructions of the back side of the outside bag of the transducer cover.
<b>!</b>	Check that the acoustic medium has no air bubbles inside the transducer cover that is covering the probe. Air bubbles inside the transducer cover can result in misdiagnosis caused by overlooking or misinterpreting lesions due to poor image quality or improper rendering.

4-3. Insertion of Probe

Insert the probe from bite block.

 <b>Warning</b>	
	Do not try to forcibly perform operations. Excessive force cause injury to the patient. If an abnormal resistance force is felt, stop use of the equipment.
	Operation must be performed by a skilled doctor. Improper operation can injure the patient. Operations must be performed by a doctor who fully understands the characteristics of ultrasound diagnostics and who is skilled and has a thorough knowledge of transesophageal echocardiography.
	Do not use the patient who has esophageal barices. This mau cause serious injury to the patient.
	Follow the information in this manual and the documentation supplied with any equipment used together with this probe. Use that is not in accordance with the supplied documentation can result in a serious or moderate injury, equipment breakdown, or physical damage that impairs operation.
	Do not use on the eyes. This probe is not intended for use on the eyes. The acoustic output can have an adverse effect on the eyes.
	Do not attempt to disassemble, modify, or repair the equipment. Electric shock or other unforeseen accidents could result. Contact one of our company and/or distributor's offices listed on the back cover to request repair.
	Do not close the probe to pacemakers. When a pacemaker and an electric apparatus for the medicine such as defibrillators are put on, Please use the probe more than 15cm apart from pacemakers .
	Do not close the probe to powerful magnetic field and magnet. It may affect to angle indication function.
	Do not close the probe to other electronic equipments. It may affect to electronic equipments function.
	Do not submerge or immerse of Proximal head and Connector into water or chemical solution . This probe is not waterproof. As a result of immersion in water or chemical solu tion, it can cause a breakdown of probe. Regarding waterproof part ,please see chapter 2-1
	Wear medical gloves during examination. Conducting examinations with the bare hands can expose the operator to a risk of infection.
	This probe must not be used in direct with the heart. This may cause patient to receive an electric shock.
	Select the size of the probe with the patient's physical constitution in mind. Using a portion that is too large and unfit for the patient's physical constitution is very dangerous and can harm the patient.
	Do not try to forcibly perform operations. Excessive force cause injury to the patient. If an abnormal resistance force is felt, stop use of the equipment.
	Use the transducer cover over the insertion portion. If the transducer cover is not used and will contact Lignocaine Hydrochloride such as xylocaine jelly or gel , this may cause exterior deterioration. If the transducer cover is not used, residual pathogens on the probe could infect the patient.

4-4. Manipulation of Probe

An image of the region of interest is displayed on the monitor of the ultrasound diagnostic instrument. For details on displaying and adjusting the image, refer to the documentation supplied with the ultrasound diagnostic instrument.





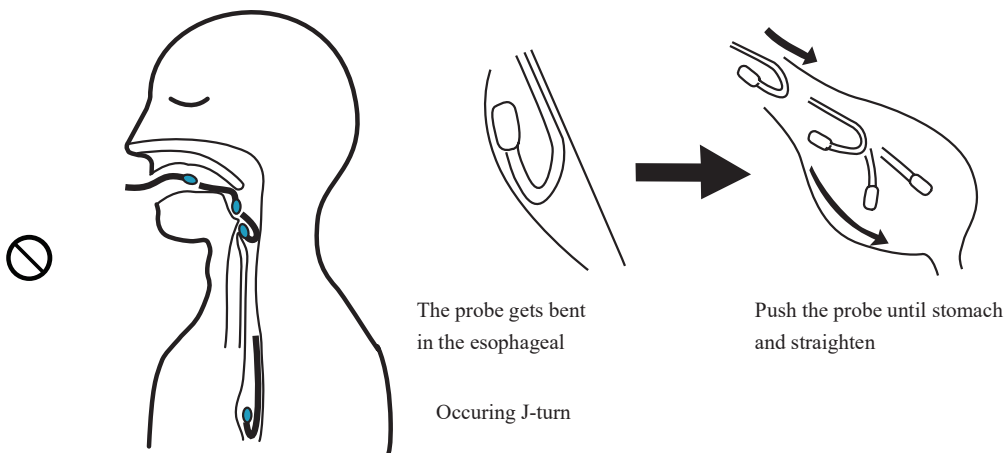









**⚠ Warning**

If the probe gets bent in the esophageal (J turn), do not try to move the probe by force. If the image reverses suddenly or the image disappears suddenly at the time of the insertion, J-turn should occur. If a J-turn should occur, do not try to pull back the probe by force, but rather, preferably under x-ray monitoring to check the state of the probe, carefully push the probe until its tip comes into the stomach and straighten the bend by operating the angle knob before pulling back the probe. Forcing it to move can injure the patient.



**!** Keep the angle knob in the free position during an operation of pulling out. Removing the deflection portion while locked may injure the patient.

**!** Dispose of the probe used for patients with Creutzfeldt-Jakob disease. Otherwise, there is a risk of infection to the operator or patient. Our ultrasound probe is not compatible with any disinfection/sterilization method for Creutzfeldt-Jakob disease.

 <b>Caution</b>	
	Constantly check for anything abnormal about the patient's condition and the equipment. Continued use without noticing that an abnormal condition has occurred can result in an electric shock and injury to the operator or patient. If an abnormal condition occurs, immediately move the equipment away from the patient and stop use of the probe.
	The equipment is vulnerable to damage by impact. Therefore, handle it with care. There is a risk of damage to the equipment when the equipment is fallen or hit somewhere.
	Do not use this probe with other equipment except for those specifically approved in the manual. Use with unapproved equipment can result in an electric shock, burn, or other injury to the patient or operator and damage to the probe and the other equipment.
	Scan for minimum time necessary at the lowest possible acoustic output. Acoustic output may affect the patient's internal tissues. For details about the acoustic output, please refer to the documentation supplied with the ultrasound diagnostic instrument.
	Regularly perform maintenance inspection and safety tests of the equipment. If you use equipment for a long period of time, it can reduce the performance, or cause smoke or fire. If anything unusual occurs, immediately stop using it and contact one of our company and/or distributor's offices listed on the back cover.
	Use, move and transport the equipment under the environmental conditions specified in this manual. Otherwise, it may be damaged.
	Do not use with a defibrillator. This should result in the probe damaged. If you have to use a defibrillator with the probe in place, make sure to conduct a safety tests according to instruction manual MN1-6105.
	Keep the angle knob in the free position during an operation of curving. Operating the probe while locked, it may become unusable.
	Do not bend or pull the insertion portion unnecessarily. This could make the probe unusable.
	Do not touch the connector terminal pin of the probe. Electrostatic discharge may result in malfunction of the probe.
	Do not touch the probe connector of the ultrasound diagnostic instrument and the patient at the same time. It can cause electric shock to the patient.
	Please hang the ring to the stand for drip infusion. If the probe is hung in the unstable point , it may the cause to drop and break down.
	After hang the probe , do not draw out Probe and do not add weight . It may the cause to drop and break down.
	When hang or remove the probe ,be careful not to drop the Probe . It may the cause to drop and break down.

4-5. Manipulation of the deflection portion

After inserting the insertion portion into the patient's esophagus, flex the tube as indicated below in order to observe the target region.

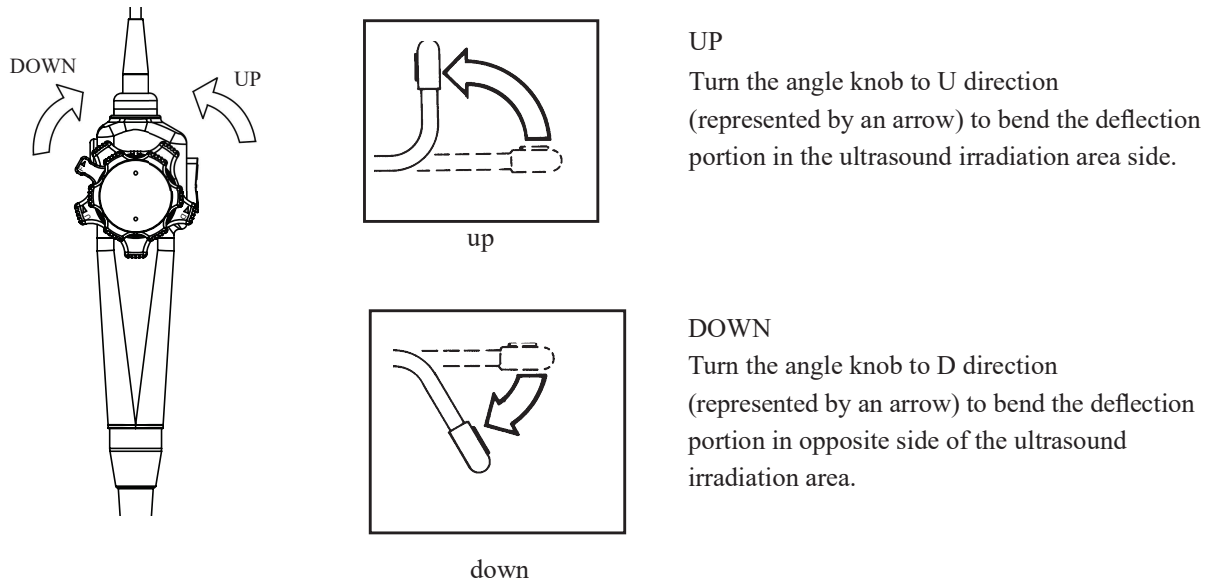

Figure 7

4-6. Manipulation of the transducer rotation

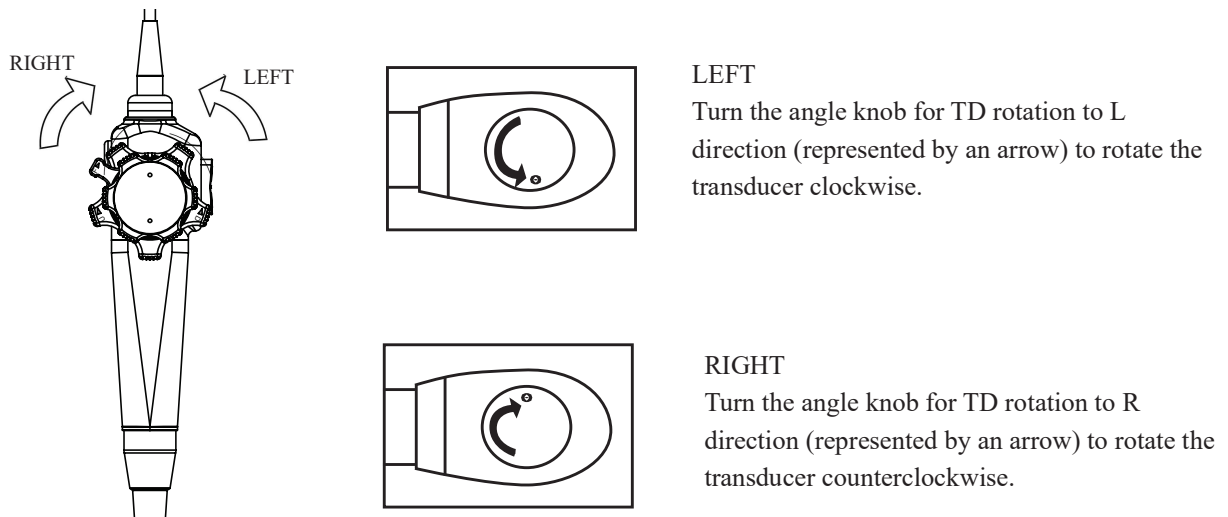

Figure 8

**⚠ Caution**

- There is no mark to indicate front direction of probe.
- It becomes right axis angle operation, turn the angle knob to clockwis See section 4-6

4-7. Manipulation of the lock lever

The mechanism of deflection portion is fixed following figure as necessary.

(1) Lock of angle knob

Turn the lock lever to fix an angle of the deflection portion and opposite direction to free.

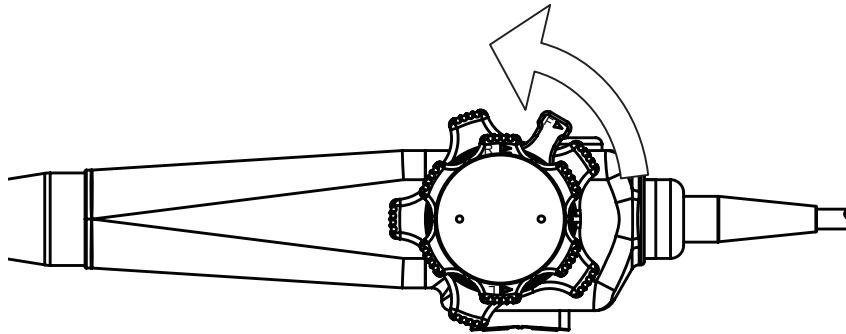





Figure 9

4-8. Removing the insertion portion

Turn free the lock lever and straighten the deflection portion in order to remove the insertion portion from the patient's esophagus.



Be sure to immediately wash and properly disinfection after use.

 <b>Warning</b>	
	Keep the angle knob in the free position during an operation of pulling out. Removing the deflection portion while locked may injure the patient.
	When blood attaches to Probe or accessories, please do cleaning and sterilization. If reuse without sterilizing, there might be the infection to the patient.

4-9. Removal of transducer cover

Transducer cover wrapped in tissue paper and removed from the probe.

Dispose of used tissue paper and transducer cover using infection prevention procedures based on the rules of your facility

 <b>Caution</b>	
	Before disposing of the equipment, disinfect or take other infection-prevention measures. Disposal of the equipment without taking the proper preventative measures can lead to infection.
	After remove the equipment from the patient, check for anything abnormal about the transducer cover. If the transducer cover stay inside of the patient's body, the transducer cover can cause injury to the patient. Remove the transducer cover including probe with carefully. When the transducer cover stay inside of the patient's body, perform the required medical treatment.



■Manufacturer



FUJIFILM Healthcare Corporation  
2-1, Shintoyofuta, Kashiwa-shi, Chiba, 277-0804 Japan

■Contact

+81-4-7131-4151  
<https://www.fujifilm.com/fhc/en>



FUJIFILM Healthcare Deutschland GmbH  
Otto-von-Guericke-Ring 3, D-65205 Wiesbaden, Germany



EU

FUJIFILM Healthcare Logistics and Services Zweigniederlassung  
der FUJIFILM Healthcare Europe Holding AG  
Otto-von-Guericke-Ring 3, D-65205 Wiesbaden, Germany



UK

FUJIFILM Healthcare UK Ltd.  
1 Davy Close, Park Farm Industrial Estate  
Wellingborough, Northamptonshire, NN8 6XX, United Kingdom



FUJIFILM Healthcare Americas Corporation  
1959 Summit Commerce Park, Twinsburg, OH 44087 USA

Distributor