

A (1:5)

L=720 1 buc  
L=716 1 buc  
L=760 2 buc

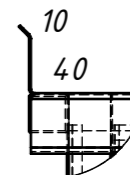

ITEM NO.	PART NUMBER	DESCRIPTION	QTY.	ДЛИНА
1	Blat 800x700	S1.2	1	
2	Carcas 1000x540x850		1	
2.1		Profil 30 X 30 X 1,2	4	820
2.2		Profil 25 X 25 X 1,2	1	797
3	polita 760x655N1	S0.8	1	
4	picior	Reglabil	4	
5	3-#1 Polita 956x463		1	
6	Spate1.1		1	
7	Laterala S		1	
8	Laterala D1		1	
9	Usa D1.1		1	
9.1	Usa V1.1.1	S 1	1	
9.2	Carcasa usa V1.2		1	
9.2.1		Profil 20 X 10 X 1,2	2	636
9.2.2		Profil 20 X 10 X 1,2	2	343.5
9.3	Miner		1	
10	Usa S1.1		1	
10.1	Usa V2.1.1	S 1	1	
10.2	Carcasa usa V1.2		1	
10.2.1		Profil 20 X 10 X 1,2	2	636
10.2.2		Profil 20 X 10 X 1,2	2	343.5
10.3	Miner		1	
11	Balama		4	
11.1	balama N1		1	
11.2	Balama N2		1	
12	Ranfort 720	S0.8	1	
13	Ranfort 716	S0.8	1	
14	Ranfort 760 B	S0.8	2	

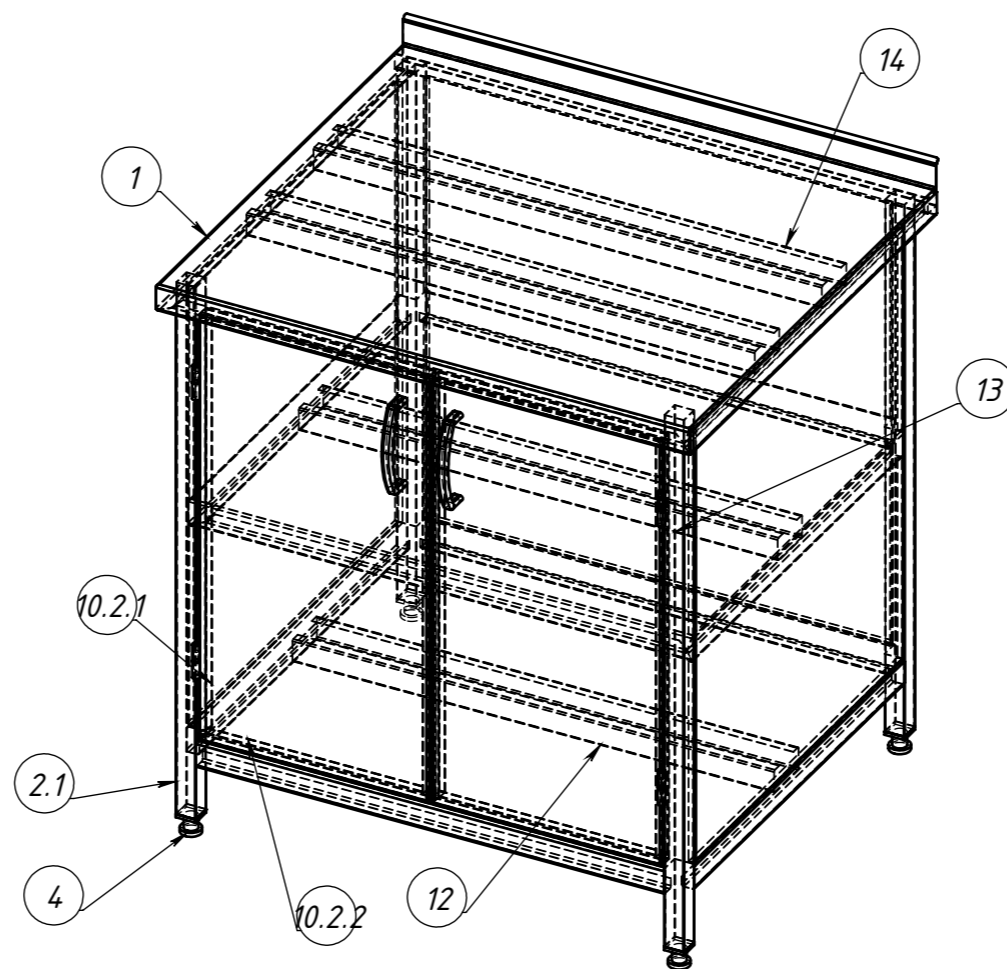

No

Client

-

Inginer

Pleșivțev Artiom

Termen ex.

\_\_.\_.2024

Masa dulap 800x700x850 cu polita

METAL EXPERT  
— TECHNOLOGY —