

Technical sheet

| | |
|-------------------------------|----------------------|
| Model line | URBAN |
| Volume | 1100 L |
| Total weight (+/- 3%) | 43.1 kg |
| Nominal load | 440 kg |
| Total permissible mass | 510 kg |
| CE marking | Yes |
| Sound power level LWA | 99 dB |
| Certification | EN840-2; RAL GZ951/1 |



| | |
|---|---|
| Material | HDPE (high density polyethylene) |
| Properties | High chemical resistance, UV protection, good impact strength, resistant to temperatures from -40° up to +80° celzius, 100% recyclable. |
| Standard colors (other colors on request) | ●RAL6011 ; ●RAL1018 ; ●RAL5005 ; ●RAL9011 ; ●RAL8011 ; ●RAL3020 ; ●RAL7021 |
| Wheels diameter | 200 mm; (other dimensions on request) |

| Packing options | | |
|-------------------|--------------------------|--|
| Standard 5 | 5 pcs/stack; 272 cm high | Lids on top, side trunnions and wheels mounted, assembly parts inside containers |
| Standard 6 | 6 pcs/stack; 301 cm high | Lids on top, side trunnions and wheels mounted, assembly parts inside containers |
| Standard 8 | 8 pcs/stack; 269 cm high | Lids on top, assembly parts inside containers |
| Optional 6 | 6 pcs/stack; 279 cm high | Lids assembled, side trunnions and wheels mounted, water plugs in last container |
| Optional 5 | 5 pcs/stack; 250 cm high | |
| Ship 6 | 6 pcs/stack; 251 cm high | Lids on top, wheels mounted on first container, assembly parts inside containers |
| Ship 7 | 7 pcs/stack; 251 cm high | Lids on top, assembly parts inside containers |

OPTIONS:

- Gravity lock, triangular lock
- RFID Chip
- Foot pedal
- Noise reduction
- Recycling inserts for glass and packaging
- Lid in Lid
- Marking: hot stamping, hot foil, labeling

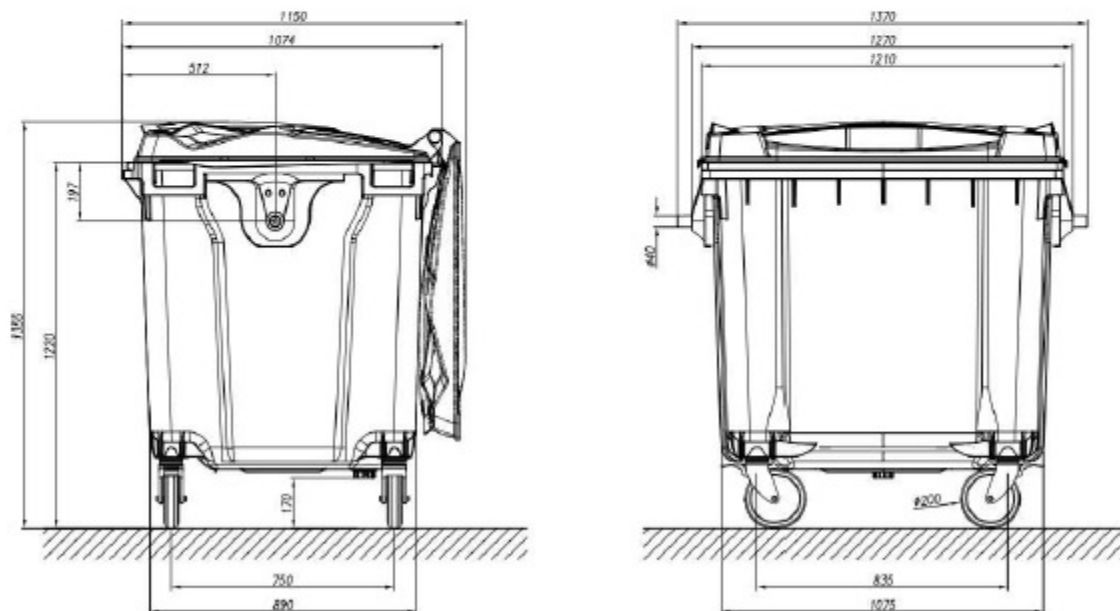

- Side handle

The image illustrating the product does not have to match the actual appearance of the product.