

# 889 Advance Post

## With Standard Width Webbing

Stylish and sleek design. Features the universal base, with the lowest leading edge on the market - enabling accessibility for all. Ideal for a variety of applications.

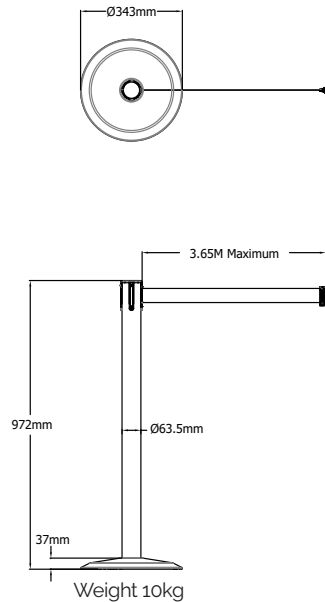
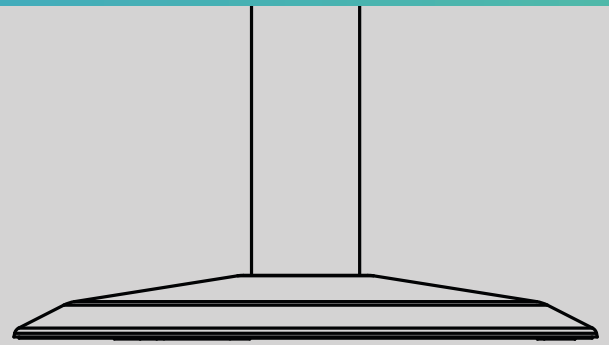

### Features & Benefits

- The advance post features a high quality steel post with a hard wearing cast iron base which has been designed with accessibility in mind.
- The edges of the base taper towards the floor to ensure wheelchairs, pushchairs and suitcases can roll over the base with ease - creating a less obstructive queue environment.
- Optimum post height, ensuring difficulty for customers to go underneath or over the webbing barrier.
- The safest barrier on the market - our cassettes have a unique braking system for slower webbing retraction.
- 36° displacement angle, preventing the post from easily toppling over.

### Product Specification

- Metal post available in a range of powder coated colours or metal finishes.
- Available with any Tensator® standard (50mm) webbing options.
- Modular webbing cassette - all cassettes come as standard with our four-point anti-tamper connectivity. This allows you to connect other Tensabarrier® products to the receiver splines on the cassette head.
- Comes as standard with an anti-tamper tape end.
- Compatible with all Tensabarrier® accessories including our range of post top signage and wall clips.

### Applications

- Enhance and manage queuing spaces.
- Cordon off out of service areas.
- Ideal for a variety of applications including: airports, retail outlets, hotels, casinos, movie theatres.

#### Order Code

- 88gU-STD - Advance Post with Universal Base 2.3m
- 88gU-MAX - Advance Post with Universal Base 3.65m

### Product Configuration

#### Base Options



Seven base options available

#### Post Finishes



Full range of metal and powder coated colours available

#### Webbing Options

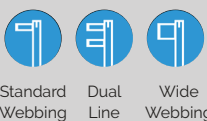

50mm width 50mm width 150mm width (each line)

#### Webbing Lengths

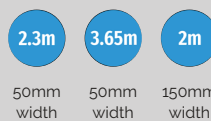

50mm width 50mm width 150mm width

#### Webbing Designs



Range of colours, designs and custom options

#### Tape End Options

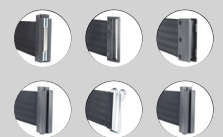

Six tape end options available

MILTON KEYNES  
+44 1908 684 600

NEW YORK  
+1-800-441-0019

DUBAI  
+971 4 2997 228

PARIS  
+33 1 43 09 85 00

FRANKFURT  
+49 69 3003 89 010

WROCLAW  
+48 71 359 3800