

LLC "Termomir"

METER – REGULATOR

BP-10B2

Passport

421413.114 PS

Lviv 2021

The BP-10V2 measuring and regulating device (hereinafter referred to as the regulator) is designed to measure temperature in conjunction with temperature transducers, regulate the value according to a given regulation law, and issue an alarm if the measured value exceeds the set limits.

1. MAIN TECHNICAL CHARACTERISTICS

1.1. Symbol of the regulator	BP-10B2
1.2. Measurement and control range, °C	-50...160
1.3. Nominal static characteristic (type of input signal)	Pt500, Pt1000
1.4. Limit of permissible basic error of the regulator, °C	$\pm(0,5+0,001 T)$
1.5. Limit of permissible basic error of the regulator complete with a thermal converter, °C	$\pm(0,8+0,006 T)$
1.6. The value of the smallest digit when indicating temperature, °C	0,1
1.7. Power supply, V, Hz	220(+22,-33), 50±1
1.8. Power consumption, no more than, V	2
1.9. Exit	
- Channel 1	PRM relay (100W, 220V)
- Channel 2	PRM relay (100W, 220V)
1.10. Degree of protection	IP65
1.11. Overall dimensions, mm	145 x 115 x 60
1.12. Average service life, not less than, years	10
1.13. Mass, not more than, kg	1
1.14. Operating conditions:	
- ambient temperature, °C	from minus 40 to 60
- relative air humidity at a temperature of 35°C, not more than, %	98
- atmospheric pressure, kPa	from 84 to 106.7

2. COMPLETENESS

Mark	Name	Number
421413.114	Meter – regulator BP-10B2	1 piece
421413.114 NOT	Operating instructions	1 copy (per batch of 10 pieces or less when delivered to one address)
421413.114 PS	Passport	1 copy
	Thermo-converter TOP-109-52	1 pc (according to customer specifications)
402211.106 PS	Passport	1 pc (according to customer specifications)

3. CERTIFICATE OF ACCEPTANCE

The measuring device-regulator BP-10B2 No. _____ complies with DSTU 3462-96 (EN 60730-1:2019, ДСТУ EN 61010-1:2014), operating instructions 421413.114 NE and this passport and is suitable for operation.

Date of manufacture _____ 202__.

The reception was held by _____ m.p.

4. MANUFACTURER'S WARRANTIES

4.1. The manufacturer guarantees compliance of the regulator with DSTU 3492-96, instruction 421413.114 NE and this passport for 24 months from the date of delivery, subject to compliance with operating and storage conditions.

4.2. The warranty period is 12 months from the date of manufacture.

5. INFORMATION ON THE CONTROL OF METROLOGICAL CHARACTERISTICS

Date of the KMH	KMX results	Position, surname, signature of the person who conducted the CMC	Note

Address of the manufacturing company:
LLC "Termomir"
Khutorivka St., 40A, office 230
Lviv, 79070
(050) 371 65 18
termomir@ukr.net



Appendix A

Using the BP-10B2 regulator to replace the TKP-160Sg

In the BP-10B2, output 1 (regulation) implements the function of turning on/off the power transformer's blower, and output 2 generates an alarm when the limit temperature is reached.

The display of the BP-10B2 regulator indicates the current temperature. The left (red) LED 1 shows the status of output 1 (regulation), the right (green) 2 - the status of output 2 (alarm).

The regulation law is two-pronged.

The control parameter is the t0 setpoint. The control reversal zone is implemented by the C_Pr parameter. The limit temperature alarm setpoint is implemented by the tShi parameter (the upper alarm setpoint for the controller). The reversal zone with this setpoint corresponds to the value of the lowest digit.

The t0 setting is called by pressing one of the buttons, after which t0 appears on the indicator, followed by the setting value, which is changed by the buttons (left - decrease, right - increase).

After pressing both buttons for a few seconds, the TYPE parameter (temperature transducer NSC) appears on the display. When using a temperature transducer with NSC Pt1000, the value P1.0 is set. After that, the Func parameter (control law) appears, which is set to 2_ _ u (in our case, 2-position reduction or cooling).

Next, the parameter t0 appears, which is already set, followed by C_Pr (the return zone, the value of which is changed using the decrease and increase buttons).

The next parameter is tShi (upper alarm setpoint, corresponding to the limit temperature, which is changed using the decrease and increase buttons).

The next parameter TSLo is set to -100 (corresponds to an unrealistic temperature).

Completion of parameter changes – Good is displayed on the display.

For rational use of available resources, the outputs of the BP-10B2 regulator are made on the same connector as in the TKP-160Sg. The difference lies in the functioning of both devices (output 1 of the regulator directly performs two-position regulation (setpoint t0) with the regulated zone C_Pr, and in the TKP-160Sg two groups of contacts are used for such regulation). It is impossible to implement the limit temperature signaling in the same TKP -160Sg.

Thus, one meter - regulator BP-10B2, performing simultaneously the functions of measurement, regulation and signaling, is able to replace two TKP-160 devices.

The actuators are connected to the normally open contacts of the BP-10B2 (output 1 (regulation) - contacts 1-4, output 2 (alarm) - contacts 1-2).

The 220V mains power cable and the TOP-109-52 resistance thermal converter signal cable are routed through hermetic entries of protection class IP67 inside the meter-regulator housing (to prevent loss of tightness and loss of the manufacturer's declared protection class IP65, it is not recommended to disassemble the meter-regulator housing). When installing the BP-10B2 regulator outside the premises or on the roof, it is advisable to use an external protective housing. This provides additional protection against intense climatic influences: hail, dust, rain, snowfall, etc. In this case, in addition to the regulator housing itself, the connector for connecting external circuits and the outputs of corrugated pipes with cables are protected: In one hole, it is necessary to route the power cable and the TOP-109-52 cable, in the other - a cable with a RSh20 connector from the control cabinet.

To insert the signal cable of the TOP-109-52 thermal converter into the hole of the additional housing, it is necessary to temporarily remove the nozzle from the thermal converter.

The outer protective case can be fixed with four fasteners through the holes in the corners of the lower part of the case. If the case will be installed in place of the TKP-160Sg, then on the lower part of the case there is a marking of 128x128 mm, in which it is necessary to drill 4 holes with a diameter of 7 mm.

When screwing into these holes, it is necessary to put rubber gaskets on the outside or seal them with silicone.

Factory settings:

Parameter	Value
tYPE	P1.0
Func	2_ _ in
t0	50.0
C_Pr	5.0
tShi	80.0
tSLo	-100

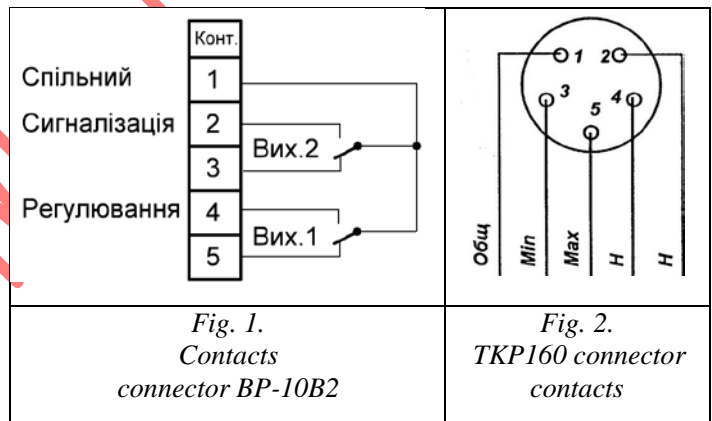

Appendix B

Installation option for the BP-10B2 meter-regulator in an additional protective housing



Кришка умовно не показана

Вид збоку

Вид ззаду

Карпус

*Вимірювач-регулятор
BP-10B2*

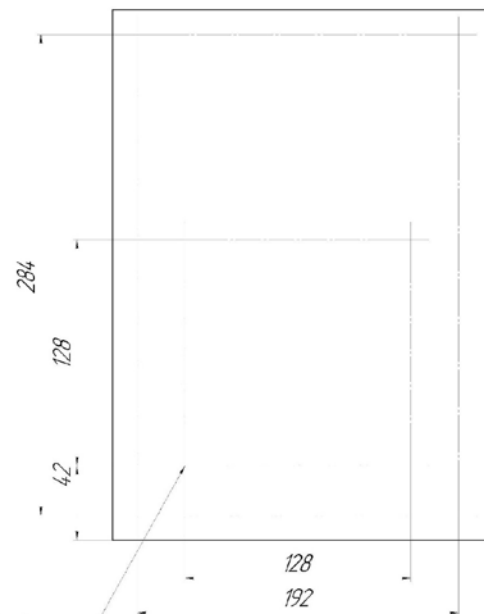
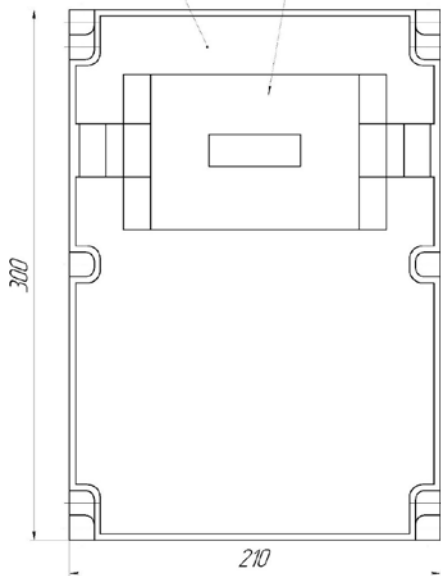

*Размітка отворів 7мм під кріплення
на місце ТКП-160*

Appendix B

Option for installing the BP-10B2 regulator without an additional protective housing

a) at the installation site of TKP-160Sg

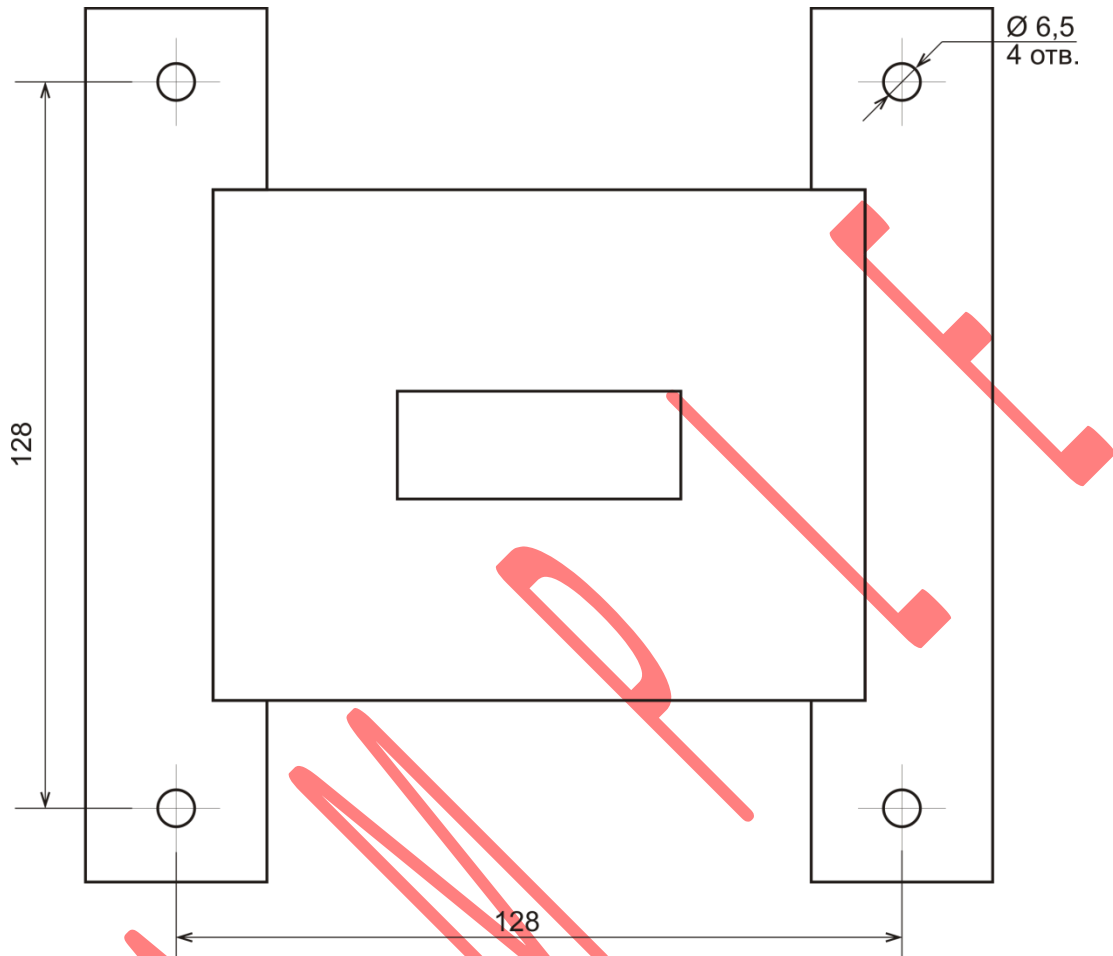

b) in an arbitrary place

