

Collimator Type

# **R-300/RC-300**





## **Operation Manual**

Read the manual thoroughly before you use the product.  
Keep this manual for future reference.

**CE 0197**

# About the Symbols Appearing in this Operation Manual

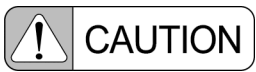
Throughout the text in this manual, warnings and other information essential when using this unit, such as cautionary or prohibited items, appear classified as per the following:

Mark	Description
	Indicates an imminently hazardous situation which, if not avoided, will result in serious injury or death.
	Indicates a potentially hazardous situation which, if not avoided, could result in serious injury or possibly death.
	Indicates a potentially hazardous situation which, if not avoided, may result in minor to moderate injury or equipment damage.
	Emphasizes additional information that is provided to ensure the proper use of this product.
	Indicates reference sections and pages.

## Revision History

Revision	Date	Changes
First Edition	Jun. 2010	-
M	2024-04-04	<ul style="list-style-type: none"> <li>Compliant with Standards.</li> <li>Added RC-300.</li> </ul>
N	2024-06-17	<ul style="list-style-type: none"> <li>Added cautions to <a href="#">3.2 "Setting the Irradiation Field"</a>.</li> <li>Changed <a href="#">7.2.2 "RC-300"</a>.</li> </ul>
P	2025-10-31	<ul style="list-style-type: none"> <li>Changed <a href="#">"Warning and Caution Labels"</a></li> <li>Changed <a href="#">1.4 "Environmental Conditions"</a></li> <li>Changed <a href="#">1.5 "Classification of Equipment"</a>.</li> <li>Changed <a href="#">1.6 "Operator Profile"</a>.</li> <li>Changed <a href="#">1.7 "Symbols"</a>.</li> <li>Changed <a href="#">3.1 "Turning the Power ON/OFF"</a>.</li> <li>Changed <a href="#">4.1 "Line Marker"</a>.</li> <li>Changed <a href="#">6.3 "Periodical Inspection"</a>.</li> <li>Changed <a href="#">7.2 "Specifications"</a>.</li> <li>Changed <a href="#">7.3 "Labels"</a>.</li> </ul>
R	2025-12-10	<ul style="list-style-type: none"> <li>Changed <a href="#">6.3 "Periodical Inspection"</a>.</li> </ul>

# Preface

Thank you for purchasing a Collimator Type R-300/RC-300 (hereafter referred to as "equipment"). This operation manual contains the information for using the collimator correctly. Read this manual before using the collimator, and use it correctly.

Failure to observe the cautions in this manual may result in damage to the collimator or harm to the patient (person being X-rayed). Also note that it is not possible to anticipate all hazards and include cautions that cover them. Therefore before using the collimator with a method not explained in the operation manual, or if you are unsure about any point in the operation manual, contact the agent from whom you purchased the collimator, or the sales office indicated at the end of this volume.

This manual should be kept available for future reference. If the user or usage location changes, ensure that this operation manual is always kept together with the equipment. Periodically check to be sure that the operation manual and the warning labels are not missing or damaged. If they are, contact your Shimadzu service representative for replacement.

Original version is approved in English.

---

## Notice

- All copyrights regarding this manual are property of Shimadzu Corporation. Neither all nor part of these contents shall be reproduced or duplicated without the express permission of Shimadzu Corporation.
- Content of this manual may be changed for improvement without notice. Although every possible effort has been made to avoid errors while creating this manual, immediate revision may not be possible in the event that errors or missing information are detected.
- Screen images and illustrations contained in this manual may differ from those in actual use, and are intended for example purposes only. Illustrations may also use partial images.
- In this manual, the illustrations of R-300 are used for explanation.
- Other company names and product names mentioned in this manual are trademarks or registered trademarks of their respective companies.
- The <sup>TM</sup> and ® symbols are omitted in this manual.

## Operating Precautions

### **"Operating Precaution (for Both the Safety and the Prevention of Danger) in the Use of Electric Medical Equipment"**

1. Nobody without the following experience and knowledge should use the equipment.
  - (1) Medical (radiographic) training (if particular qualifications are required in the country concerned, those qualifications must be held).
  - (2) The capacity to read and understand the operation manual.
2. When installing the equipment, pay attention to the following items:
  - (1) Do NOT install it near water faucet or similar equipment.
  - (2) Install it away from potential sources of problems such as abnormal pressure, temperature or humidity, drafts, direct sunlight, dust, chlorine or sulphur gas.
  - (3) During transportation and operation of the equipment, avoid tilting, vibration and sharp impact against it.
  - (4) Keep the equipment away from areas where chemicals or gases are stored.
  - (5) Use only the correct electrical power source with matching frequency, voltage and current (or wattage).
  - (6) Check the conditions of the battery power source (power and polarity) before operating the equipment.
  - (7) Properly ground the equipment.
3. Before operating the equipment, pay attention to the following items:
  - (1) Check the conditions of switch contacts, polarity, dial settings, and meters, and make sure the equipment performs correctly.
  - (2) Confirm that the ground is connected properly.
  - (3) Check all wiring for proper and correct connections.
  - (4) Check the condition of the external electric circuit, which will be directly connected to a patient.
  - (5) Check the condition of the battery power source.

4. While operating the equipment, pay attention to the following items:
  - (1) Do NOT exceed time or the amount of equipment use needed for diagnosis or therapy.
  - (2) Observe the equipment and patient continuously for early detection of problems.
  - (3) When a problem is detected with the equipment or patient, take proper action to stop the equipment without harming the patient.
  - (4) Do NOT let the equipment touch the patient unless necessary.
5. After operating the equipment, pay attention to the following items:
  - (1) Turn off the switches and return the dial to their original positions before use in the prescribed order. Then, turn off the main power switch.
  - (2) Do NOT pull the power cable forcibly from the outlet.
  - (3) When storing the equipment, pay attention to the following items:
    - (i) Keep it away from water.
    - (ii) Store it away from potential causes of problems such as abnormal pressure, temperature and humidity, draft, direct sunlight, dust, chlorine or sulphur gas.
    - (iii) During transportation and storage of the equipment, avoid tilting, vibration and sharp impact against it.
    - (iv) Store the equipment away from areas where chemicals and gases are stored.
  - (4) Clean all attachments, cables and contacts, and store them in one place.
  - (5) Keep the equipment clean to avoid problems during the next use.
6. When the equipment is found to be out of order, do NOT try to repair it. Display an appropriate sign to indicate that the equipment is out of order, and contact a Shimadzu service representative for repair.
7. Do NOT modify any part of the equipment.
8. Preventive maintenance
  - (1) The equipment and its parts should be periodically checked.
  - (2) If the equipment has not been in operation for an extended period of time, test it prior to actual operation to make sure it works correctly and safely.
9. Concerning other items, operate properly according to the operation manual.

## Precautions in Usage

When using this equipment, please observe the following precautions for the safety of the operator and patient.



**The responsibility for management of use and maintenance of medical equipment lies with the user.**

This equipment is restricted to use by, or under supervision of, a diagnostic radiology technician or a person with a certificate indicating equal proficiency. Repair and inspection of the inside of the equipment is dangerous. Be sure to contact your Shimadzu service representative for repair and inspection.



**Never modify the equipment.**

In general, modifications are strictly prohibited by the Regulatory requirements of the law of the country where the equipment is installed. Please contact your Shimadzu service representative if it is necessary to modify the equipment.



**Perform periodic inspection.**

Preventive maintenance is required to maintain long-term safety and performance of the equipment.

The "[6 Maintenance](#)" chapter in this manual gives detailed descriptions of daily and periodic maintenance and inspection that a user should perform.

As for the maintenance and inspection that only specially trained experts can perform, utilize the maintenance agreement program offered by Shimadzu.



**Repair and maintenance of the inside of the equipment can only be performed by engineers assigned by Shimadzu.**

Maintenance must be assigned to specially trained experts. Contact your Shimadzu service representative for repair and maintenance.



**Connect this equipment only to Shimadzu certificated devices or devices that are proven to be safe and show no performance degradation in any combination including connecting system.**



**If the operator has no experience in operating the equipment, be sure that he or she receives instruction on how to operate it from Shimadzu service personnel or someone who has adequate experience in using the equipment.**

In order to operate the equipment safely, an explanation of the operation needs to be given. When installing the equipment, Shimadzu service personnel explain the operating procedure using this operation manual. Follow their directions and operate the equipment correctly.

 Reference ["1.6 Operator Profile" P.7](#)

## Be sure to Read the Following to Prevent Explosion, Electric Shock, or Injury

---



**Do NOT use any potentially flammable or explosive gas, such as disinfectant sprays, near the equipment.**

Use of such gas may cause an explosion.



**Check the condition of the patient before conducting a study.**

If equipment usage is deemed to put the patient at risk due to the his or her condition, refrain from conducting the study or treatment.



**Do NOT use the equipment in places where liquid may enter.**

The equipment is not designed to be waterproof. Invasion of any liquid should cause electric shock, system failure or malfunction.



**Do NOT spill any liquid, such as contrast medium, saline, or disinfectant, onto the equipment.**

Should such liquid drip on equipment surfaces, wipe it off immediately. Any such liquid entering into system electronics may cause failure or malfunction.

Should liquid drip on the equipment or enter the covers, immediately turn off the power and contact your Shimadzu service representative.



**When there is any abnormality in operation, or unusual smell or smoke emission during operation, stop operation immediately and contact your Shimadzu service representative.**

Continued use may damage the equipment and cause injury.



**Do NOT open the covers of the equipment.**

Otherwise, electric shock may result. When opening the covers for maintenance, contact your Shimadzu service representative.



**Always be very careful when moving the equipment to avoid contact with the patient or operator and to ensure that the patient or operator does not become caught between the equipment and any neighboring devices.**

Otherwise, it may cause injury.

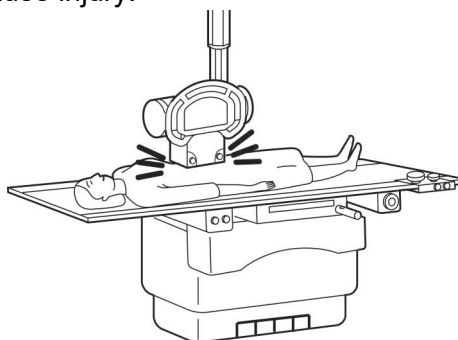

**Do NOT use in a location where metal fragments may enter the equipment.**

This can result in electric shock.



**Do NOT perform any maintenance work of the equipment during study.**  
The patient may be injured.

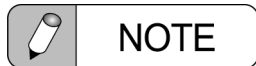

Accuracy of displayed values is not guaranteed. Displayed values measured by the measurement functions of this equipment are not absolute values but relative values based on the capability of the instruments used.

## Cautions on Environmental Conditions

---



**Do NOT use the equipment in an oxygen-rich environment.**  
The use in an oxygen-rich environment may cause fatal or serious injuries or damage to the equipment due to easy ignition.



**Be sure to use the equipment under the specified environmental conditions:**  
**The installation of a dedicated air-conditioner in the examination room is recommended if the building air-conditioner cannot meet the necessary environmental conditions.**

 Reference ["1.4 Environmental Conditions" P.3](#)

Note also that there must be no sudden changes in temperature or humidity. This causes condensation, which can lead to equipment failure.

## Cautions on Radiography



**Restrict all persons other than the patient from accessing the equipment in accordance with local regulations.**

To avoid unnecessary exposure, acceptable distances (maximum access values) to the equipment by any person other than the patient are defined for each region.



**The equipment can be operated only by qualified personnel, such as radiology technicians or those with equivalent qualifications.**



**No person but the patient is allowed to stay in the examination room during X-ray irradiation.**

If the equipment is not used correctly, the operator, the patient, and other persons may receive a greater dose of radiation than necessary.



**Perform X-ray irradiation carefully and according to the doctor's directions when using the equipment with expectant mothers, women who suspect they are pregnant, lactating women, or children.**

Particular ways of using the equipment may increase the scatter dose absorbed into the patient, which may cause a radiation hazard.



**Always check the X-ray exposure region using the collimator lamp.**

Irradiating a patient with X-rays outside the required region risks exposure the patient to unnecessary radiation.



**During X-ray irradiation, ensure that the X-rays irradiate the necessary region only.**

To avoid unnecessary exposure, narrow down the collimator and take protective measures, such as wearing a protective apron.



**Do NOT place any unnecessary object in the location within the X-ray exposure region.**

Doing so may result in unnecessary radiation exposure to the patient.



**Be sure to carry out a warm-up (running-in operation of the X-ray tube unit) before taking an X-ray radiograph.**

Follow the warm-up procedure described in the X-ray high-voltage generator operation manual.

**Perform the warm-up if an arc occurs.**

Suddenly using the X-ray tube unit near the nominal X-ray tube voltage (above 100 kV) after using the unit at a relatively low tube voltage (80 kV max.) for a prolonged period may result in arc. This arc occurs due to loss of the warm-up effect at high tube voltage after the X-ray tube unit is used at a relatively low tube voltage for a prolonged period.

In this case, warm up the X-ray tube unit by referring to the procedure described in the X-ray high-voltage generator operation manual.

**Do NOT perform unnecessary standby operations.**

If standby status continues after the radiography preparation button is pressed, wire disconnection or withstand voltage failure may result owing to the evaporation of the X-ray tube filament.

**In order to minimize the radiation dose on the patient, make the distance between the focus and the patient's body surface as long as possible (Minimum 45 cm).**

The shorter the distance becomes, the greater the amount of scatter dose absorbed into the patient, which may cause a radiation hazard.

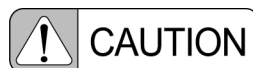
**Pay extra attention when irradiating X-rays for a long time or repeatedly.**

It may cause a radiation hazard.

## Cautions on Cleaning and Disinfection

---



**Be sure to turn the equipment power OFF before cleaning and disinfecting the equipment.**

Otherwise, a malfunction may occur in the equipment, or the equipment may operate in an unintended way.

Also, thoroughly ventilate the room before turning ON the power after disinfection work is complete.



**Be sure to clean and disinfect the equipment periodically.**

Cleaning and disinfection is very important to ensure that the equipment can be used hygienically and safely. Strictly follow the methods prescribed.



**Be sure to clean the equipment frequently and after each patient use.**

While doing so, do NOT directly apply or spray any disinfectant, cleaner, or water onto the equipment. Wipe down all contact surfaces using a cloth moistened with an appropriate disinfectant or cleaner. Make sure the cloth is NOT too wet. If it is, liquid may enter into system electronics, causing failure or malfunction.

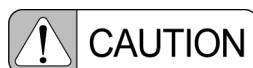
**Use the following disinfectants (intermediate level disinfectant):**

- Chlorine disinfectants
  - Sodium dichloroisocyanurate solution (1 % maximum)
  - Sodium hypochlorite solution (1 % maximum)
- Alcohol disinfectants
  - Commercially available isopropyl alcohol solution (Up to 99 wt% can be used)
- Rubbing alcohol
  - (76.9 - 81.4 vol% Ethanol, Isopropyl alcohol as an additive)

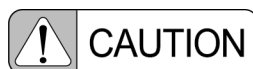
**Do NOT use the following disinfectants:**

If any of the following disinfectants are applied, the equipment performance and safety cannot be guaranteed.

- Disinfectants that corrode metals, plastics, rubber, or paint
- Disinfectants unsuitable for metals, plastics, rubber, or paint
- Spray-gas type disinfectants
- Volatile disinfectants
- Disinfectants that may enter the equipment

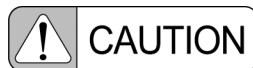
**Use disinfectants at a minimum.**

Repeated disinfection over a long time may lead to discoloring and cracking on the equipment surface, and deterioration of rubber and plastic. If any abnormality is found on the equipment after disinfection, stop using the equipment immediately. Contact your Shimadzu service representative for repair.

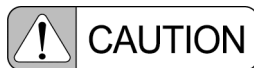

**Do NOT use an organic solvent.**

Organic solvents may change the surface color. If an organic solvent adheres to the surface, wipe it out immediately.



**When disinfecting unpainted metals, do NOT use chlorine-based disinfectants.**

Chlorine-based disinfectants may corrode the surface of the equipment. If chlorine-based disinfectants adhere to the surface, wipe them off immediately.

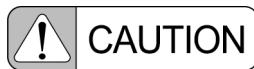

**When disinfecting resin parts such as reticule of the collimator, do NOT use rubbing alcohol.**

Rubbing alcohol may lead to deformation or crack of resin parts such as reticule of the collimator. Wipe it off immediately if it adheres to the reticule of the collimator.



**When cleaning resin parts such as reticule of the collimator, use cloth lightly moistened, not soaked, with cold or warm water mixed with neutral detergent that does not include organic solvent.**

Rubbing alcohol, organic solvents or non-neutral detergents may lead to deformation or crack of resin parts such as reticule of the collimator. Wipe them off immediately if they adhere to the reticule of the collimator.

On completing the work, check the following points before switching the power ON again.

- There must be no water or disinfectant adhering to the equipment.
- The tools used in cleaning and disinfecting work must be tidied away.

**Reference** ["3.1 Turning the Power ON/OFF" P.22](#)



**When turning the power ON after cleaning, make sure the examination room is properly ventilated.**

Turning the power ON while any flammable gas remains in the examination room could lead to fire, smoke, explosion or electrocution.

## Cautions Relating to Cellular Telephones

---



**Do NOT bring any cellular telephones or related devices into the examination room with their power ON.**

Such devices can exceed the EMC standard limitations, and under some conditions this can impair the proper functioning of the equipment. In the worst case, this can cause serious injuries or clinical errors.

## Cautions on Electromagnetic Compatibility (EMC)

---



**This equipment needs special precautions regarding EMC.**

Install and use the equipment according to the EMC information provided in this operation manual.

 **Reference** ["7.1 Environmental Conditions of EMC \(Electromagnetic Compatibility\)" P.60](#)



**Make sure that electromagnetic compatibility is obtained.**

All peripheral devices must satisfy EMC standards regarding emission of electromagnetic energy and susceptibility to electromagnetic environment.

Devices that do not satisfy these standards may disturb the correct functioning of the equipment. In the worst case, this can cause serious injuries or clinical errors.

 **Reference** ["7.1 Environmental Conditions of EMC \(Electromagnetic Compatibility\)" P.60](#)



**Do NOT use this equipment adjacent to, or stacked with, other equipment.**

If adjacent or stacked use is necessary, check to be sure that this equipment works properly in the environment.

 **Reference** ["7.1 Environmental Conditions of EMC \(Electromagnetic Compatibility\)" P.60](#)



**Do not use accessories, transducers and cables other than those specified or provided by Shimadzu.**

The use of accessories, transducers and cables other than those specified or provided by Shimadzu could result in increased electromagnetic emissions or decreased electromagnetic immunity of this equipment and result in improper operation.



**Portable RF communications equipment (including peripherals such as antenna cables and external antennas) should be used no closer than 30 cm (12 inches) to any part of the R-300/RC-300, including cables specified by the manufacturer.**

Otherwise, degradation of the performance of this equipment could result.



**Portable RF communications equipment (including peripherals such as antenna cables and external antennas) using TETRA (TERrestrial Trunked RADio) should not be used no closer than 50 cm to any part of the R-300/RC-300, including cables specified by the manufacturer.**

Otherwise, degradation of the performance of this equipment could result.



**Portable RF communications equipment (including peripherals such as antenna cables and external antennas) using Bluetooth, Wireless LAN (2.4 GHz), RFID, LTE (Band7) should not be used no closer than 45 cm to any part of the R-300/RC-300, including cables specified by the manufacturer.**

Otherwise, degradation of the performance of this equipment could result.



**Portable RF communications equipment (including peripherals such as antenna cables and external antennas) using GSM 180, CDMA 1900, GSM 1900, DECT, LTE Band 1,3,4,25, UMTS should not be used no closer than 45 cm to any part of the R-300/RC-300, including cables specified by the manufacturer.**

Otherwise, degradation of the performance of this equipment could result.

---

## Cautions When Irradiating Consecutive Pulse X-rays

---



**Observe the following precautions when irradiating consecutive pulse X-rays:**

- Conducting studies involving irradiating consecutive pulse X-rays onto the region where an implantable pacemaker or defibrillator is implanted may cause these devices to malfunction.
- Refer to the "Important General Cautions," "Interactions," or other relevant sections in the accompanying documentation of the implantable pacemaker or defibrillator and take the prescribed measures before irradiating the implanted region of these devices with consecutive pulse X-rays.

Fluoroscopy or radiography performed by irradiating consecutive pulse X-rays (such as serial radiography with a few second intervals, pulsed fluoroscopy, digital angiography, DSA, or cineradiography) can adversely affect the CMOS circuit in implantable pacemakers and defibrillators. Such affects may cause oversensing in these devices that can temporarily inhibit pacing pulse output and result in an inappropriate heart rate.

## Warranty

The system is warranted to be free from defects in material and workmanship for one year from the date of delivery. If found to be defective, the system must be offered to Shimadzu for inspection and examination. Upon examination, Shimadzu, at its sole option, will repair or replace at no charge, the system or any part found to be defective. Components which wear are not warranted.

This warranty extends to original purchaser or the lessee of the new system only.

If the system is to be resold or delivered to a third party, such third party must be provided with a copy of this manual, the installation manual and the technical manual supplied with the system.

This warranty does not apply to the following:

1. Failure or damage due to any installation, relocation, or service not provided by your Shimadzu service representative or a SHIMADZU designated contractor.
2. Failure or damage caused by the product of other companies (except those purchased from SHIMADZU).
3. Failure or damage due to repairs using non-SHIMADZU certified service parts.
4. Failure or damage due to non-compliance with the notices and procedures set forth in this manual.
5. Failure or damage due to any operating environment deviating from the requirements set forth in this manual.
6. Failure or damage due to natural disasters such as power surge, rain, fire, earthquake, flood, and thunder.
7. Failure or damage due to being equipped with non-SHIMADZU approved vehicle, ship, aircraft, or others.
8. Failure or damage due to use in non-SHIMADZU certified countries.
9. Failure or damage in case of purchase from a store other than SHIMADZU or the Shimadzu service representative.
10. Failure or damage due to hit, drop, and shock.

Service after the expiration of the warranty is available at a reasonable cost and should be performed by your Shimadzu service representative.

IN NO EVENT SHALL SHIMADZU AND ITS AFFILIATED ENTITIES BE LIABLE TO ANY PERSON OR ENTITY FOR ANY DIRECT, INDIRECT, INCIDENTAL, SPECIAL OR CONSEQUENTIAL DAMAGES (INCLUDING, WITHOUT LIMITATION, ANY DAMAGES RESULTING FROM LOSS OF USE, BUSINESS INTERRUPTION, LOSS OF PROFITS, LOSS OF SAVINGS, THE COST OF PROCUREMENT OF SUBSTITUTED GOODS, SERVICES OR TECHNOLOGIES OR FOR ANY MATTER ARISING OUT OF OR IN CONNECTION WITH THE USE OR INABILITY TO USE THE SYSTEM.

In some jurisdictions, some of the foregoing warranty disclaimers or damage limitations may not apply.

Shimadzu will be indemnified for any claim, liability, or damage arising out of the misuse or non-compliance with this manual by the purchaser or lessee of the system.

## Service Life

The equipment lifetime is 10 years (based on Shimadzu's criteria) assuming the specified maintenance checks are performed.

## Disposal Precautions

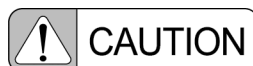

**When disposing of the equipment, contact your Shimadzu service representative.**

An improper disposal of this equipment may pollute the environment by substances contained in parts.

## Action for Environment (WEEE)

To all users of Shimadzu equipment in the European Union:

Equipment marked with this symbol indicates that it was sold on or after 13th August 2005, which means it should not be disposed of with general household waste. Note that our equipment is for industrial/professional use only.

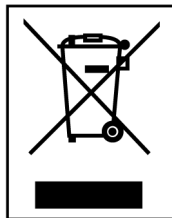

WEEE Mark

**Contact your Shimadzu service representative when the equipment has reached the end of its life. They will advise you regarding the equipment take-back.**

With your co-operation we are aiming to reduce contamination from waste electronic and electrical equipment and preserve natural resource through re-use and recycling. Do not hesitate to ask your Shimadzu service representative, if you require further information.

## Software

The information in this manual is based on the following software.

- R-300  
Version: R300.V01  
Revision: 2.\*
- RC-300  
Version: RC300.V01  
Revision: 1.\*

\* : Even if the last digit of the revision is different from that above, the descriptions in the manual are valid.

## Warning and Caution Labels

The following safety labels, which describe handling precautions, are attached to the equipment. With adequate understanding of the contents on these labels and the warning/caution items in this manual, operate the equipment safely.

Inspect the safety labels periodically (once a year).

If any label is peeled or unreadable by stain or scratch, replace it with a new one.

For new labels, contact your Shimadzu service representative.

- R-300

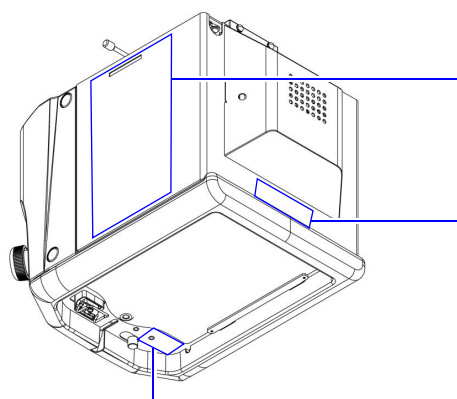

Warning label

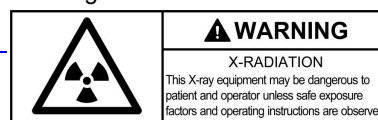

Caution label (for Halogen Lamp Type)



Caution label (option: Only if laser model number is LDS163LSS.)



- RC-300

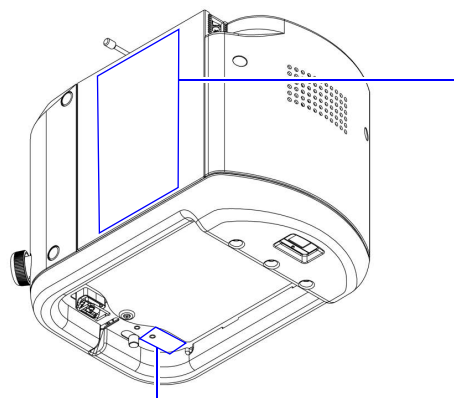

Warning label

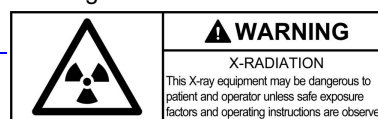

Caution label (option: Only if laser model number is LDS163LSS.)



## Abbreviations

Abbreviation	Explanation
SID	Source Image Distance
LED	Light Emitting Diode
DR	Digital Radiography
CR	Computed Radiography
FPD	Flat Panel Detector

## Options

The "Options" described in this manual may be provided as standard, or may be unavailable, depending on the sales format.

# Contents

## Preface

Precautions in Usage .....	iv
Be sure to Read the Following to Prevent Explosion, Electric Shock, or Injury .....	vi
Cautions on Environmental Conditions .....	viii
Cautions on Radiography .....	ix
Cautions on Cleaning and Disinfection .....	xii
Cautions Relating to Cellular Telephones .....	xv
Cautions on Electromagnetic Compatibility (EMC) .....	xvi
Cautions When Irradiating Consecutive Pulse X-rays .....	xix
Warranty .....	xx
Service Life .....	xxi
Disposal Precautions .....	xxi
Action for Environment (WEEE) .....	xxii
Software .....	xxii
Warning and Caution Labels .....	xxiii
Abbreviations .....	xxiv
Options .....	xxiv

## Chapter 1 Outline

1.1 Applications .....	2
1.2 Features .....	2
1.3 Principle .....	3
1.4 Environmental Conditions .....	3
1.4.1 Operation Environment .....	3
1.4.2 Transportation and Storage Environment .....	4
1.4.3 Power Supply .....	4
1.4.4 Grounding .....	5
1.5 Classification of Equipment .....	6
1.6 Operator Profile .....	7
1.7 Symbols .....	8

## Chapter 2 Part Names and Functions

---

2.1	System Appearance	10
2.1.1	R-300	10
2.1.2	RC-300	12
2.2	Operation Panel (R-300)	14
2.2.1	When Combined with General Radiography Equipment	14
2.2.2	When Combined with Fluoroscopy Equipment (FLEXAVISION system)	17
2.2.3	When Combined with Fluoroscopy Equipment (SONIALVISION G4 system)	18
2.3	Operation Panel (RC-300)	19
2.4	Display Panel (R-300)	19
2.5	Display Panel (RC-300)	19

## Chapter 3 Operation

---

3.1	Turning the Power ON/OFF	22
3.2	Setting the Irradiation Field	23
3.2.1	When Combined with General Radiography Equipment	23
3.2.2	When Combined with Fluoroscopy Equipment (FLEXAVISION system)	30
3.2.3	When Combined with Fluoroscopy Equipment (SONIALVISION G4 system)	32
3.3	Auto-Filter	35
3.3.1	Types of X-ray Filter	35
3.3.2	X-ray Filter Selection	36

## Chapter 4 Options

---

4.1	Line Marker	38
4.2	Dose Calculation Unit	41
4.3	Area Dosimeter Unit	41
4.4	Polygonal Collimator (C-leaves)	42
4.5	Single-acting H Mask	42

## Chapter 5 Troubleshooting

---

5.1 List of Error Messages .....	44
5.2 When You Suspect a Fault .....	46

## Chapter 6 Maintenance

---

6.1 Maintenance Check .....	50
6.2 Daily Inspections (Inspections Carried Out by the User) .....	51
6.2.1 Checklist for Daily Inspection .....	51
6.2.2 Checking Light Field .....	52
6.2.3 Checking the Warning and Caution Labels .....	52
6.2.4 Cleaning and Disinfection .....	53
6.3 Periodical Inspection .....	57
6.4 Maintenance Parts List .....	58

## Chapter 7 Specifications

---

7.1 Environmental Conditions of EMC (Electromagnetic Compatibility) .....	60
7.2 Specifications .....	64
7.2.1 R-300 .....	64
7.2.2 RC-300 .....	65
7.2.3 Options .....	66
7.3 Labels .....	67
7.3.1 R-300 .....	67
7.3.2 RC-300 .....	70
7.4 Statement of Compliance [For Europe] .....	72
7.4.1 Regulatory Information .....	72
7.4.2 Company's Quality System .....	72
7.4.3 International Standards .....	72
7.5 Statement of Compliance with Standards .....	73
7.6 Manufacturer Information .....	73
7.7 Product Safety .....	74

## Appendix

---

# Chapter *1*

---

## Outline

### ■ Contents

1.1	Applications .....	2
1.2	Features .....	2
1.3	Principle .....	3
1.4	Environmental Conditions .....	3
1.5	Classification of Equipment .....	6
1.6	Operator Profile .....	7
1.7	Symbols .....	8

## 1.1 Applications

### ■ Intended Use

The collimator R-300 is fitted to the X-ray tube unit and is used to adjust the X-ray irradiation field. Its size can be known by the emission field of visible light and the indication on the display panel.

The collimator RC-300 is fitted to the X-ray tube unit and is used to adjust the X-ray irradiation field. its size can be known by the emission field of visible light. Additionally, when combined with the ceiling type X-ray tube support CH-200, its size can be known by the indication on the operation panel of CH-200.

### ■ Indications for Use

This unit is used for radiographic and fluoroscopic examinations of whole body except mammography and interventional procedure when combined with an X-ray high voltage generator, an X-ray tube unit, and if necessary, an X-ray tube support, an X-ray radiography stand, an X-ray radiography table or an X-ray diagnostic table, and digital radiography system.

This unit must only be operated by qualified personnel, such as radiography technicians or those with equivalent qualifications.

This unit is used for total patient population including pediatric examination.



- **Do NOT use the system for any other purpose than indicated above.**
- **Do NOT connect the system to any other equipment, either by electrical or mechanical means, or modify the system.**

## 1.2 Features

The collimator has a structure of multiplex leaves that removes a great quantity of extra-focal X-rays. Furthermore, an auto-filter automatically switches X-ray filters (among "no filter" and three types of filters ) according to the selected radiography menu option. This structure and these functions serve to improve the radiographic effects of the X-rays and to reduce the X-ray dose exposed to the patient.

## 1.3 Principle

The X-ray irradiation field size can be adjusted when the leaves are opened or closed by using the irradiation field adjustment knob. It can also be adjusted by the control signal of the X-ray tube support that is being used in combination with the collimator.

## 1.4 Environmental Conditions

To obtain proper performance, be sure to use the equipment under the specified environmental conditions.

### 1.4.1 Operation Environment

Use the equipment under the environmental conditions listed below:

The installation of a dedicated air-conditioner in the examination room is recommended if the building air-conditioning cannot meet the necessary environmental conditions.



**Do NOT use the equipment in an oxygen-rich environment.**

The use of the equipment in an oxygen-rich environment may cause fatal or serious injuries or damage to the equipment due to easy ignition.



**Even under the prescribed conditions, avoid rapid changes of temperature or humidity.**

Condensation may occur and cause failure. Also, rust or corrosion may occur inside the equipment.

Item	Specifications
Atmosphere	No explosive or corrosive gases
Ambient Temperature	10 °C to 40 °C
Relative Humidity	30 % to 85 % (with no condensation)
Atmospheric Pressure	800 hPa to 1060 hPa
Environment Luminosity	150 lx to 500 lx
Ambient Noise Level	Under 70 dB

### 1.4.2 Transportation and Storage Environment

Item	Specifications
Temperature	-10 °C to 60 °C
Humidity	10 % to 95 % (with no condensation)
Atmospheric Pressure	700 hPa to 1060 hPa

### 1.4.3 Power Supply

Item	Specifications
Phase	DC
Standard Voltages	24 V
Permitted Voltage Range	±0.1 V of standard voltage
Supply Capacity	150 VA (without polygonal collimator (C-leaves)) 240 VA (with polygonal collimator (C-leaves) or when combined with SONIALVISION G4 system)
Power Supply	150 VA: Supplied from Ceiling X-ray Tube Support 240 VA: Supplied from G4 system



**Be sure to use the power supply specified in the operation manual.**  
Using a power supply other than the one specified may cause equipment malfunction or serious accidents such as fire, smoke emission, or explosions.

## 1.4.4 Grounding

1

Grounding resistance: less than 100  $\Omega$



**Be sure to connect the equipment only to a (commercial) power outlet with a ground terminal.**

If the outlet does not have a ground terminal, electric shock may occur.

# 1.5 Classification of Equipment

This equipment is classified as follows, based on safety standards for electrical medical equipment.

■ **Protection Method Against Electric Shock**

Class I equipment

■ **Classification of Applied Parts**

No Applied Parts according to IEC 60601-1:2005

■ **Operation Mode**

Continuous operation

■ **Degree of Protection Against Liquid Ingress**

Ordinary equipment

■ **For Use in an Oxygen-rich Environment**

 **WARNING**

**Do NOT use the equipment in an oxygen-rich environment.**  
The use in an oxygen-rich environment may cause fatal or serious injuries or damage to the equipment due to easy ignition.

■ **For Use in Flammable Atmosphere**

 **DANGER**

**Do NOT use the equipment or system in the presence of flammable anesthetics gas.**  
It may cause an explosion.

■ **Classification of Installation Type**











Permanently installed equipment

# 1.6 Operator Profile

Item	Details
Age	Age that person can obtain the license of Radiological Technologist or a license equal to it.
Sex	No limitation
Nationality	No limitation
Education	Radiological Technologist or person who has a license equal to it. The capacity to read and understand the operation manual.
Knowledge	Radiological Technologist or person who has a license equal to it.
Language	Can read and understand English.
Experience	Necessary. Every operator needs to take training for operating the equipment before using the equipment.
Permissible impairments	Corrected visibility is over 0.7 in the decimal number. Impaired by 40 % resulting in 60 % of normal hearing at 500 Hz to 2 kHz.

# 1.7 Symbols

Symbols used on this equipment are shown below:

Symbol	Location	Meaning
	On name plate	Direct Current
	On warning label	Risk of X-radiation
	On caution label	High temperature
	On caution label	Do NOT look directly at the laser beam
	On name plate	Refer to operation manual
	On warning and caution labels	Observe described items, or refer to operation manual.
	On name plate	Refer to operation manual
	On name plate	Serial number
	On name plate	Month and year of manufacture
	On name plate	Manufacturer
	On the right side of the equipment	Refer to operation manual

# Chapter 2

---

## Part Names and Functions

### ■ Contents

2.1	System Appearance .....	10
2.2	Operation Panel (R-300) .....	14
2.3	Operation Panel (RC-300) .....	19
2.4	Display Panel (R-300) .....	19
2.5	Display Panel (RC-300) .....	19

# 2.1 System Appearance

## 2.1.1 R-300

**■ Front / Right Side**

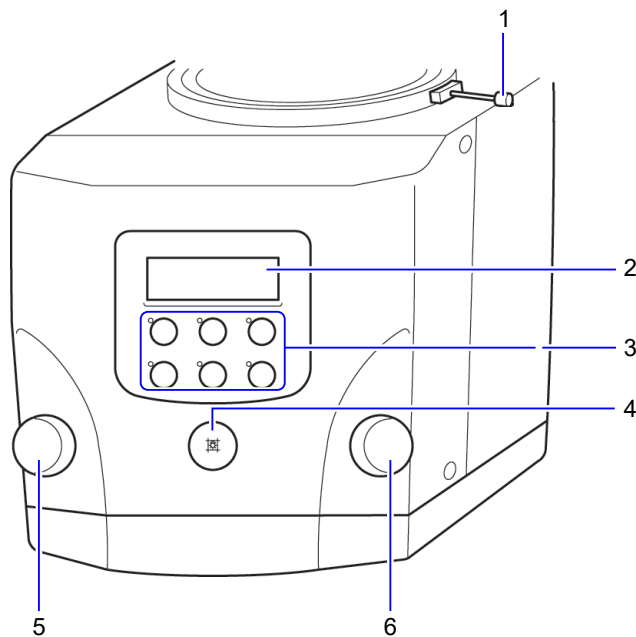

\* : Equipment suitable for use in the patient environment.

No.	Name	Function	See
1	Stopper	Used to secure the collimator.	P.28
2	Display panel	Displays the irradiation field, SID and so on.	P.19
3	Operation panel	Used to change the SID indication, to automatically select the X-ray filter and to perform other operations.	P.14
4	Lamp button	On pressing this button, the collimator lamp and line marker (option) are turned on for the set amount of time. On pressing it again, the collimator lamp and line marker are turned off.	P.25, P.39
5	Irradiation field adjustment knob (for H-leaves)	Used to adjust the irradiation field size.	P.26
6	Irradiation field adjustment knob (for V-leaves)		

## Bottom

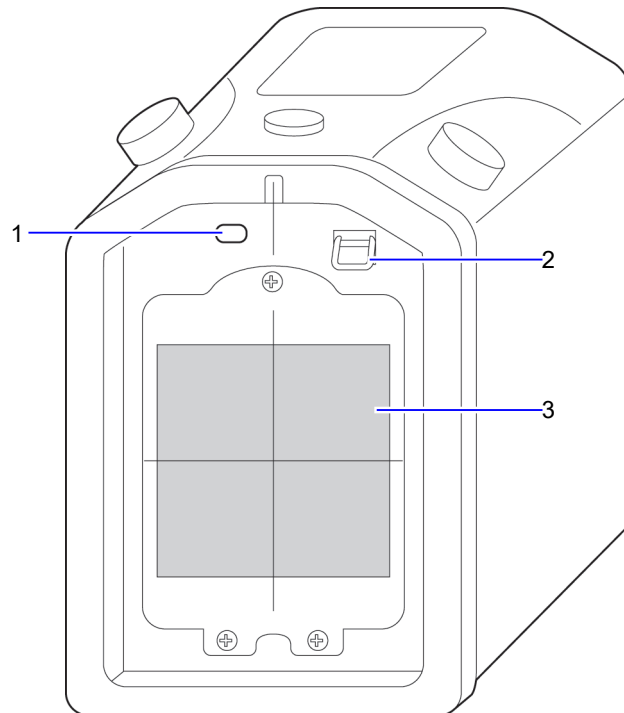

2

No.	Name	Function	See
1	Line marker shielding slide switch	Selects whether the line marker (option) is emitted or not according to whether the shutter is open or closed.	P.38
2	Tape measure	Used to measure the exposure distance.	P.24
3	Reticule	Displays a cross marking in the center of the irradiation field when the lamp has been turned on.	-

## 2.1.2 RC-300

### ■ Front / Right Side

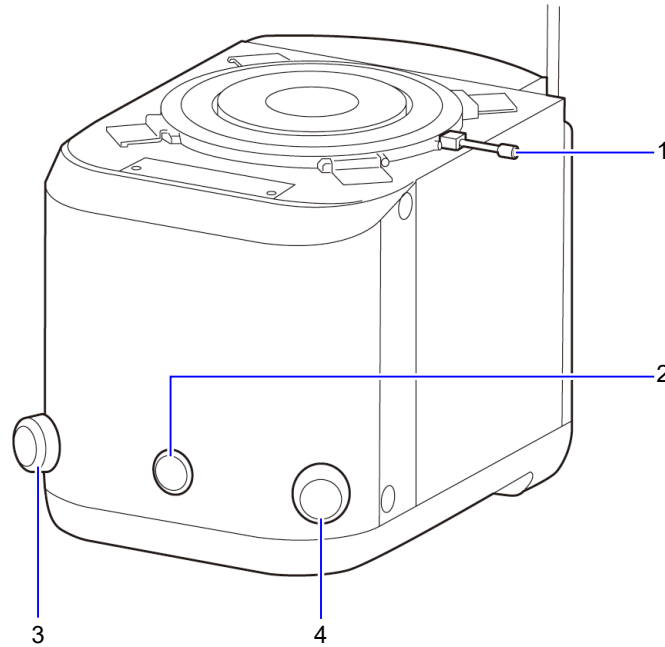

\* : Equipment suitable for use in the patient environment.

No.	Name	Function	See
1	Stopper	Used to secure the collimator.	P.28
2	Lamp button	On pressing this button, the collimator lamp and line marker (option) are turned on for the set amount of time. On pressing it again, the collimator lamp and line marker are turned off.	P.25, P.39
3	Irradiation field adjustment knob (for H-leaves)	Used to adjust the irradiation field size.	P.26
4	Irradiation field adjustment knob (for V-leaves)		

## Bottom

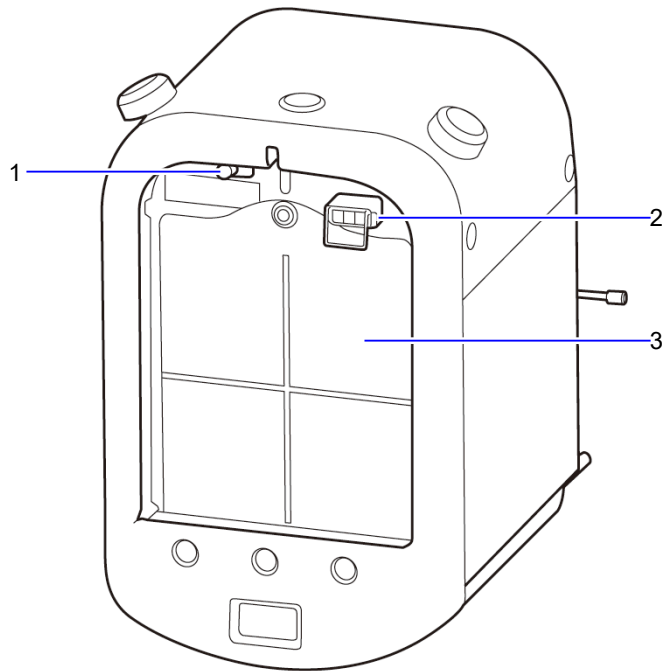

2

No.	Name	Function	See
1	Line marker shielding slide switch	Selects whether the line marker (option) is emitted or not according to whether the shutter is open or closed.	P.38
2	Tape measure	Used to measure the exposure distance.	P.24
3	Reticule	Displays a cross marking in the center of the irradiation field when the lamp has been turned on.	-

## 2.2 Operation Panel (R-300)

### 2.2.1 When Combined with General Radiography Equipment

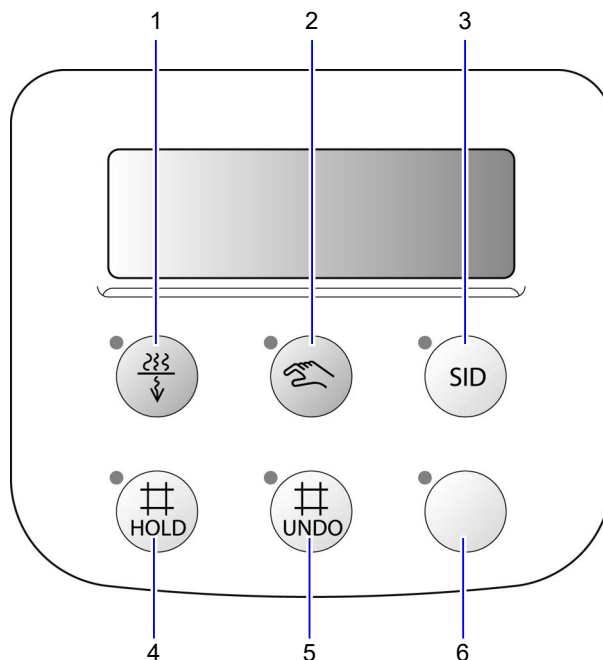

No.	Name	Function	See
1	Filter selection button	Enables you to select from among three types of X-ray filter.	P.35
2	Manual operation button	On pressing this button its LED lamp lights and the interlock with the cassette size featured on the radiography stand or radiography table is released, allowing you to set the irradiation field with this equipment.	P.23
3	SID change button	Changes the SID taken as the basis for the irradiation field in general radiography or manual operation. Successive actuations of this button cycle the SID through the sequence: 1000 → 1500 → 1800 → 2000 → 1000. The irradiation field will be calculated based on the set SID, and will be shown in the display panel.	-

No.	Name	Function	See
4	HOLD button	<p>Used to perform radiography without changing the size of the irradiation field, for example examining the cervical vertebrae from four directions.</p> <p>When combined with a system that allows the irradiation field size to be changed for each exposure and the preset radiography size is the same, the irradiation field size is fixed even if this button is pressed and the radiography menu selection is changed before starting radiography.</p> <p>If the following condition changes occur the system is automatically turned OFF.</p> <ul style="list-style-type: none"> <li>• Examination is ended (when combined with a system that can provide notification of examination start/end).</li> <li>• The preset radiography size is changed to a different radiography menu option.</li> <li>• The radiography size is changed.</li> <li>• The manual operation button is pressed and the LED lights.</li> </ul> <p>When combined with a system that does not allow the irradiation field size to be changed for each exposure and the cassette size is the same, the irradiation field size is fixed even if this button is pressed and the cassette loaded into the radiography table or radiography stand is replaced before starting radiography.</p> <p>If the following condition changes occur, the system is automatically turned OFF.</p> <ul style="list-style-type: none"> <li>• Examination ends (when combined with a system that can provide notification of examination start/end).</li> <li>• The radiography size is changed.</li> <li>• The manual operation button is pressed and the LED lights.</li> </ul>	-
5	UNDO button	<p>Used when an image is crippled.</p> <p>When combined with a system that allows the irradiation field size to be changed for each exposure, after an image is crippled, press this button to return to the original radiography menu option and reinstate the irradiation field size when the next radiography menu option has been selected and the irradiation field size has been changed automatically.</p> <p>When combined with a system that does not allow the irradiation field size to be changed for each exposure, after an image is crippled, replace the cassette loaded into the radiography table or radiography stand and press this button to reinstate the irradiation field size.</p> <p>Also, if you forget to press the HOLD button in radiography such as examining the cervical vertebrae from four directions, you can fix the irradiation field size by pressing this button and then the HOLD button.</p>	-
6	Spare button	This is a spare button. It cannot be operated.	-



Before pressing the  button, check whether a cassette for radiography has been loaded.

When performing manual operation, it is possible to radiate X-rays even when a cassette that has already been used for radiography is still loaded, or when no cassette is loaded.

In order to avoid unnecessary exposure, set the irradiation field and check that a cassette for radiography has been loaded before starting radiography.

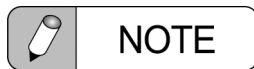

Contact your Shimadzu service representative when changing the location of any button on the operation panel.

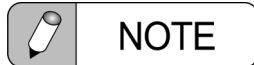

The preset values to be loaded by the SID change button can be changed. Contact your Shimadzu service representative if you wish to change them.

## 2.2.2 When Combined with Fluoroscopy Equipment (FLEXAVISION system)

2

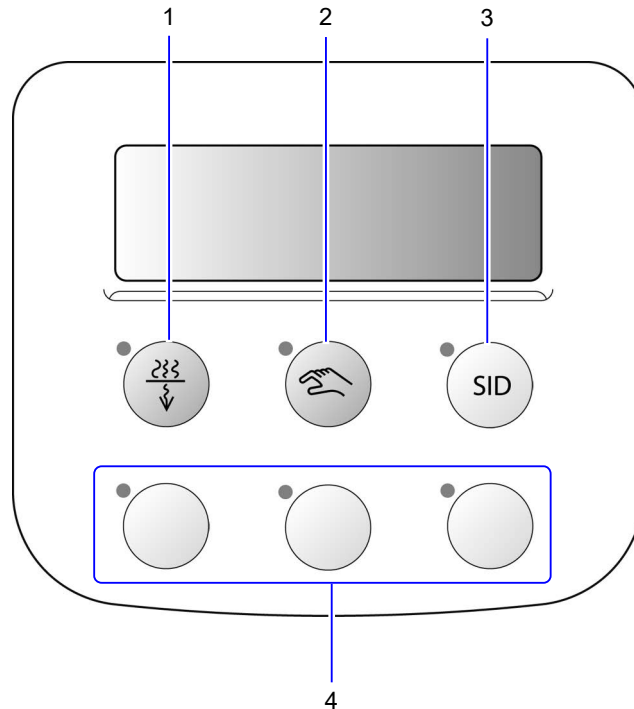

No.	Name	Function	See
1	Filter selection button	Enables you to select from among three types of X-ray filter. This button cannot be used when performing fluoroscopy.	P.35
2	Knobs/remote selection button	Used to make the irradiation field adjustment knobs effective with the DR technique. When this button is lit, the irradiation field can be set with the knobs.	P.30
3	SID change button	Used to change the SID, which is the reference for the irradiation field, when the SID is displayed. The SID changes each time the button is pressed. The irradiation field is calculated based on the set SID and shown in the display panel. The SID is not displayed in the condition that allows fluoroscopy.	-
4	Spare button	This is a spare button. It cannot be operated.	-

### 2.2.3 When Combined with Fluoroscopy Equipment (SONIALVISION G4 system)

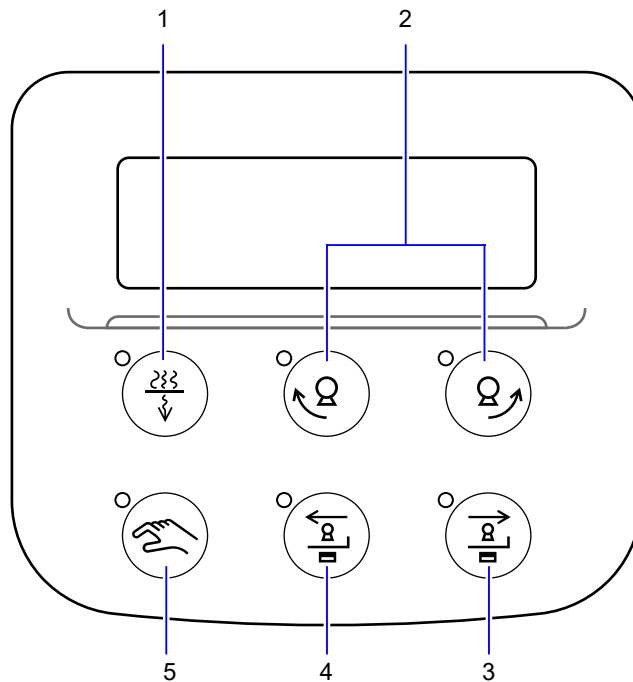

No.	Name	Function	See
1	Filter selection button	Changes the BH filter.	P.35
2	X-ray tube unit slant button	Slants the X-ray tube unit in the direction of the arrow when the tabletop is in the vertical position.	-
3	Imaging unit shift button (towards the feet)	The imaging unit moves towards where the patient's feet are.	-
4	Imaging unit shift button (towards the head)	The imaging unit moves towards where the patient's head is.	-
5	Manual operation button	When the LED is on, the irradiation field can be adjusted by the collimator open/close knob. When DR technique is selected, the LED comes on if this button is pressed only if the  button is arranged on the console.	P.32

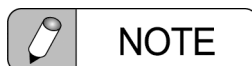

Contact your Shimadzu service representative when changing the location of any button on the operation panel.

## 2.3 Operation Panel (RC-300)

When using RC-300, buttons are displayed on the touch panel of the X-ray tube support CH-200. For details, refer to the operation manual of the X-ray tube support CH-200.

 **Reference** CH-200 Operation Manual

2

## 2.4 Display Panel (R-300)

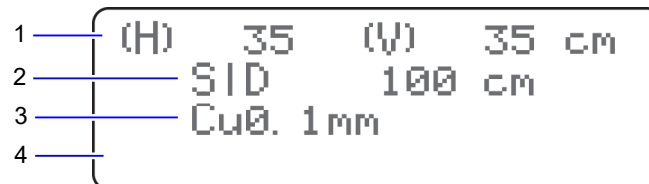

No.	Name	Function	See
1	Irradiation field	The irradiation field is displayed here. (Units: cm/inch)	P.23
2	SID	The SID, which is the reference for the irradiation field size indication, is displayed here. However, when using a technique that allows fluoroscopy (DR technique), it will not be displayed.	P.14
3	Auto-filter	The type of filter is displayed here.	P.35
4	Message	Error messages and messages in response to operations are displayed here.	P.44

## 2.5 Display Panel (RC-300)

When using RC-300, indications are displayed on the touch panel of the X-ray tube support CH-200. For details, refer to the operation manual of the X-ray tube support CH-200.

 **Reference** CH-200 Operation Manual

This page is intentionally left blank.

# Chapter 3

---

## Operation

### ■ Contents

3.1	Turning the Power ON/OFF .....	22
3.2	Setting the Irradiation Field .....	23
3.3	Auto-Filter .....	35

## 3.1 Turning the Power ON/OFF

Turning the power to the X-ray high-voltage generator ON/OFF also turns the power to the equipment ON/OFF.



**When turning the power supply ON/OFF, follow the instructions appearing in the separate operation manual for the X-ray high-voltage generator or fluoroscopy equipment.**

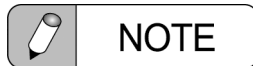

Before turning the power ON, carry out a routine inspection and check that there is no abnormality in the equipment or in the system as a whole. For details, refer to the operation manual of the X-ray high-voltage generator that is being used in combination with the collimator, or that of the system.

 **Reference** "6.2 Daily Inspections (Inspections Carried Out by the User)" P.51

### ■ Operation for Turning the Power ON

When the power is supplied, the motors that control the shielding leaves perform a home positioning operation. This positioning operation ends about 10 seconds after the power has been turned ON. When the positioning operations of each of the motors have ended the irradiation field size is displayed and the collimator can be used.

## 3.2 Setting the Irradiation Field

The procedure for setting the irradiation field differs depending on the radiography equipment being used in combination with the equipment, and the system as a whole.

### 3.2.1 When Combined with General Radiography Equipment

3



**Always check the X-ray irradiation region using the collimator lamp.**

Irradiating a patient with X-rays outside the required region risks exposing the patient to unnecessary radiation.

The procedure for setting the irradiation field is as follows, depending on the radiography conditions selected with the X-ray high-voltage generator.

Radiography Conditions	Setting Procedure	See
General radiography, simple cassette radiography (when using the general radiography technique)	Set the irradiation field with the irradiation field adjustment knob on the equipment.	P.23
Other than general radiography or simple cassette radiography (when using e.g. the vertical Bucky, horizontal Bucky, or tomography technique)	The size of the irradiation field is set based on the Bucky device in which the cassette is loaded, the FPD unit and so on. Since with the equipment it is set automatically according to the radiography conditions, there is no need to make any setting, but if necessary you can finely adjust the irradiation field using the irradiation field adjustment knob.	P.27

#### ■ With General Radiography or Simple Cassette Radiography



**The operator must take due care to avoid unnecessary exposure, and set the irradiation field before starting radiography.**

### 3 Operation

---

- 1 Select radiography conditions in which general radiography or simple cassette radiography is set with the X-ray high-voltage generator.
- 2 Measure the exposure distance using the tape measure on the bottom face of the equipment.

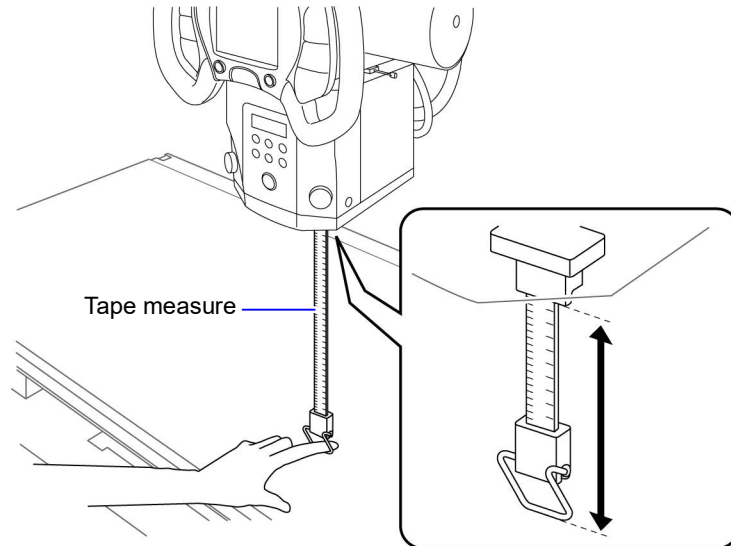

#### CAUTION

**When returning the tape measure after it has been drawn out, keep hold of the metal fixture at the end until the tape has been reeled fully back in.**

If you let go of the metal fixture part way the tape will be retracted too vigorously, and it could hit somebody and injure them or break parts.

#### NOTE

- The tape measure is marked out in both inches and centimeters.
- The scale on the tape measure shows the distance from the focal spot of the X-ray tube.

### 3 Press the lamp button.

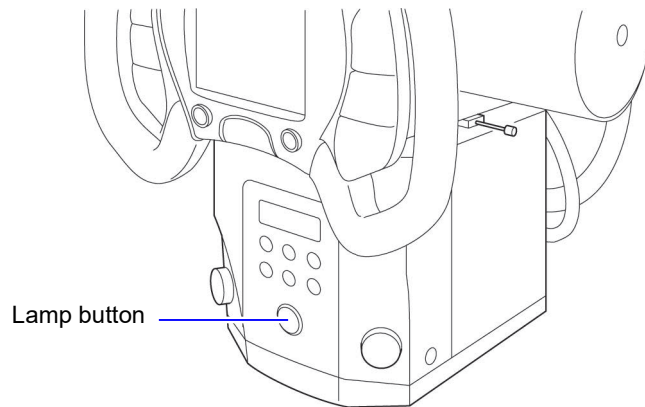

The lamp lights.

If the collimator is equipped with the line marker (option), it also lights up.

 Reference "4.1 Line Marker" P.38



**Do NOT look directly into the line marker.**

Looking at it directly could cause loss of sight.



**Do NOT touch on the rear of the collimator during use and after use for lamp.**

The high temperature on the rear of the collimator may burn injury.

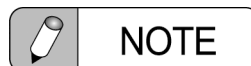

If the message "Lamp-ON time limited" appears on the display panel, the lamp does not light. After the message disappears, turn the lamp on.

- 4 Adjust the irradiation field using the irradiation field adjustment knob.

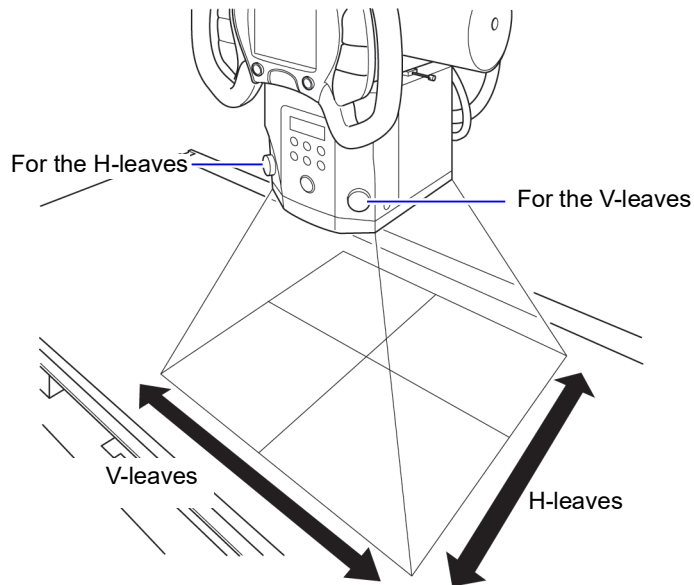

 NOTE

It is possible to exchange the functions of the knobs at the right and left sides, and to set them to operate with the same turning directions as on other collimators manufactured by Shimadzu (the R-20J/R-30H and so on).  
The maximum size setting of the irradiation field can be changed.  
Contact your Shimadzu service representative before changing the settings.

- 5 Press the lamp button again.

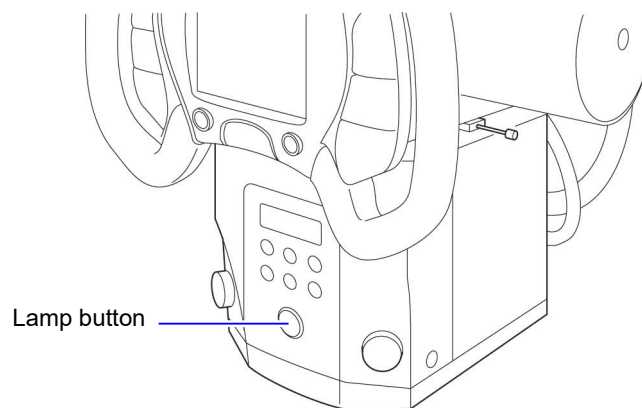

The lamp goes out.

The lamp will go out automatically after the set amount of time even if you don't press the lamp button.

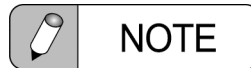

When using R-300, the time that the lamp stays on can be set from 5 to 30 seconds at installation.

When using RC-300, the time that the lamp stays on can be set from 5 to 60 seconds at installation.

For details on this setting, contact your Shimadzu service representative.

### ■ With Conditions Other Than General Radiography or Simple Cassette Radiography

- 1 Select conditions other than general radiography or simple cassette radiography with the X-ray high-voltage generator.  
Set the FPD, a cassette or the CR cassette in the Bucky device. The irradiation field will be determined.
- 2 Adjust the irradiation field size using the irradiation field adjustment knob.  
The irradiation field size can be adjusted within the area of FPD, cassette or CR cassette size.

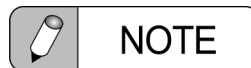

- When using RC-300, the irradiation field size cannot be adjusted using the irradiation field adjustment knobs while CH-200 is in motion.
- Compensation is automatically performed so that even if the distance between the focal spot and the image receptor changes, the irradiation field maintains a constant size. When adjusting the irradiation field, refer to steps 3 to 5 of "[With General Radiography or Simple Cassette Radiography](#)" P.23.
- When radiography conditions other than general radiography or simple cassette radiography have been selected, it is not possible to enlarge the irradiation field size set in the radiography conditions.

### ■ Turning the Collimator

On loosening the stopper on the right hand side of the collimator, the collimator can be turned 45 degrees both to the right and left.

This facility can only be used when the collimator is used in combination with general radiography equipment.

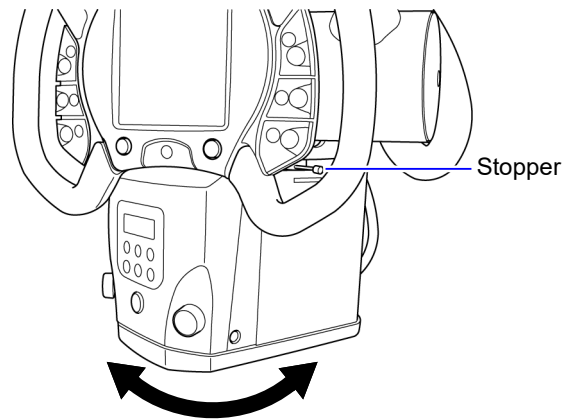

**When turning the collimator, do NOT turn it beyond 45 degrees.**  
Doing so may cause failure to the collimator.



**On turning the collimator, check that the X-ray tube is facing in the correct direction before starting radiography.**



**When turning the collimator, create as long an exposure distance as possible and as small an X-ray field as possible, before performing X-ray exposure.**

When the collimator is turned, corners of the X-ray field may be missed depending on the degree of turning, the amount of narrowing, and the maximum X-ray field of the X-ray tube unit.



**On turning the collimator, mind the openings in it.**  
You could get fingers trapped and sustain an injury.



**After turning the collimator, secure it by tightening the stopper properly.**  
If the stopper is left not fully tightened, the angle of the collimator may change.

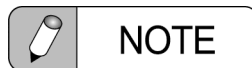

When the detent (option) is fitted, as you turn it back into place, you will sense a click that makes it easy to locate the position.

### 3.2.2 When Combined with Fluoroscopy Equipment (FLEXAVISION system)

Radiography Conditions	Setting Procedure	See
General radiography, simple cassette radiography, FPD portable radiography	Set the irradiation field with the irradiation field adjustment knobs on the equipment.	P.30
Technique that allows fluoroscopy (DR technique)	Set the view field size to the maximum irradiation field size with the fluoroscopy equipment's collimator handle, and then set the irradiation field. The setting can also be made with the irradiation field adjustment knobs after pressing the  (knobs/remote selection) button on the operation panel or the touch panel of the X-ray tube support CH-200.	P.31

#### ■ With General Radiography, Simple Cassette Radiography or FPD Portable Radiography

 **WARNING**

**Always check the X-ray irradiation region using the collimator lamp.**  
 Irradiating a patient with X-rays outside the required region risks exposing the patient to unnecessary radiation.

The radiography procedure is the same as for general radiography or simple cassette radiography when the collimator is combined with general radiography equipment.

 **Reference**    ["With General Radiography or Simple Cassette Radiography" P.23](#)

## ■ With a Technique that Allows Fluoroscopy (DR Technique)



**WARNING**

The operator must take due care to avoid unnecessary exposure, and set the irradiation field before starting fluoroscopy/radiography.

3

### Setting with the Collimator Handle

For details, refer to the operation manual for the system with which the collimator is combined.

**Reference** Operation manual for FLEXAVISION

### Setting with the Irradiation Field Adjustment Knobs

- 1 Select the technique that allows fluoroscopy (DR technique) with the X-ray high-voltage generator.  
Set the FPD in the FPD tray.  
The irradiation field will be determined.
- 2 Press the (knobs/remote selection) button on the operation panel or the touch panel of the X-ray tube support CH-200.  
The irradiation field size can be adjusted within the area of possible irradiation field size.
- 3 Adjust the irradiation field size with the irradiation field adjustment knobs.  
The irradiation field size can be adjusted within a range that doesn't exceed the size of the irradiation field of the FPD or image intensifier.

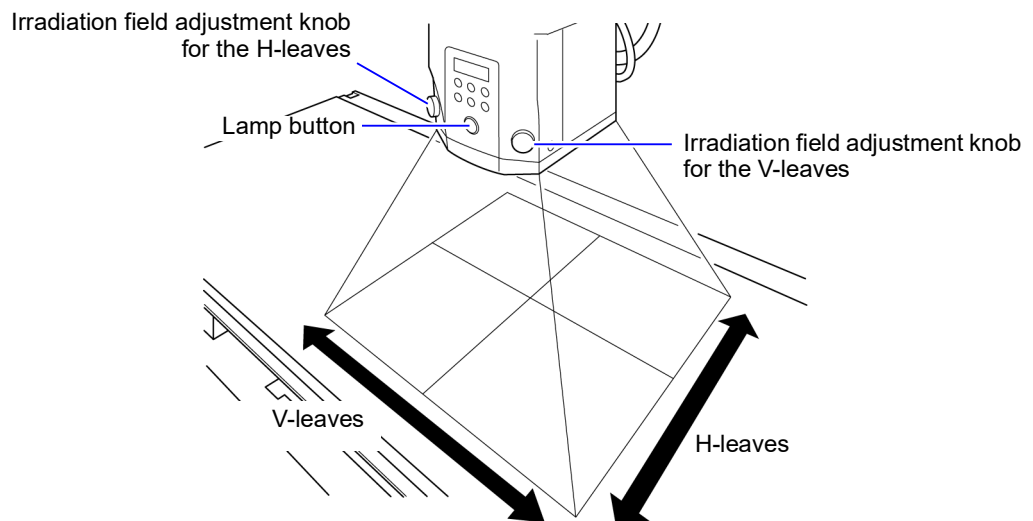



 NOTE

- Compensation is automatically performed so that even if the distance between the focal spot and the image receptor changes, the irradiation field remains a constant size.
- When radiography conditions other than general radiography or simple cassette radiography have been selected, it is not possible to enlarge the selected irradiation field size.

**■ Turning the Collimator**

This facility cannot be used when the collimator is used in combination with fluoroscopy equipment.

**3.2.3 When Combined with Fluoroscopy Equipment (SONIALVISION G4 system)**

Radiography Conditions	Setting Procedure	See
Technique that allows fluoroscopy (DR technique)	Set the view field size to the maximum irradiation field size with the fluoroscopy equipment's collimator handle, and then set the irradiation field. Only if the button  is arranged on the console, the setting can also be made with the irradiation field adjustment knobs after pressing the  (Manual operation) button on the operation panel or the touch panel of the X-ray tube support CH-200.	P.31
Other techniques	Set the irradiation field with the irradiation field adjustment knobs on the equipment.	P.30

**■ With General Radiography**

 WARNING

**Always check the X-ray irradiation region using the collimator lamp.**  
Irradiating a patient with X-rays outside the required region risks exposing the patient to unnecessary radiation.

The radiography procedure is the same as for general radiography or simple cassette radiography when the collimator is combined with general radiography equipment.

 **Reference** "With General Radiography or Simple Cassette Radiography" P.23

### ■ With a Technique that Allows Fluoroscopy (DR Technique)



**The operator must take due care to avoid unnecessary exposure, and set the irradiation field before starting fluoroscopy/radiography.**

3

#### Setting with the Collimator Handle

For details, refer to the operation manual for the system with which the collimator is combined.

 **Reference** Operation manual for SONIALVISION G4

#### Setting with the Irradiation Field Adjustment Knobs

This function is available only if the  button is arranged on the console.

- 1 Select the technique that allows fluoroscopy (DR technique).  
The irradiation field will be determined.
- 2 Press the  (Manual operation) button on the operation panel or the touch panel of the X-ray tube support CH-200.  
The irradiation field size can be adjusted within the area of possible irradiation field size.
- 3 Adjust the irradiation field size with the irradiation field adjustment knobs.  
The irradiation field size can be adjusted within a range that doesn't exceed the size of the irradiation field of the FPD or image intensifier.

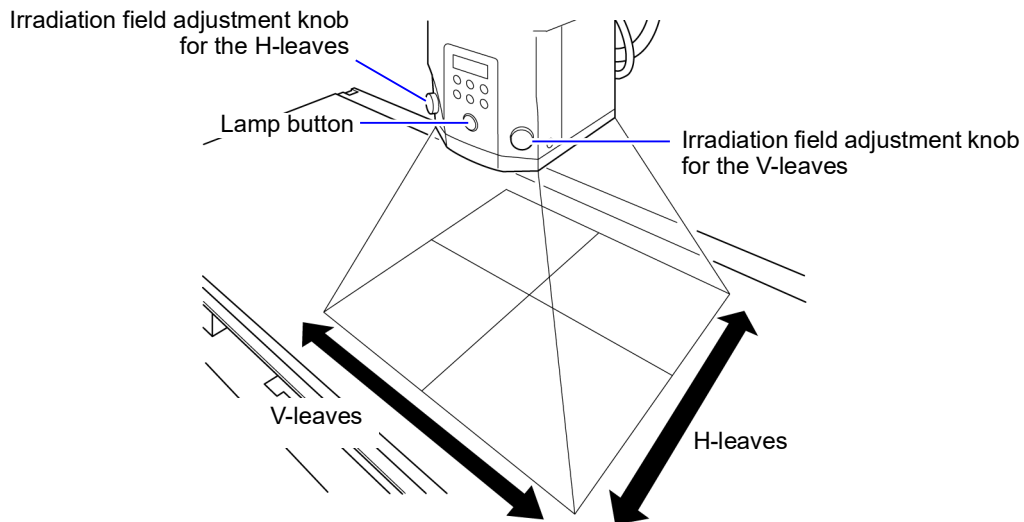

 **NOTE**

- Compensation is automatically performed so that even if the distance between the focal spot and the image receptor changes, the irradiation field remains a constant size.
- When radiography conditions other than general radiography have been selected, it is not possible to enlarge the selected irradiation field size.

#### **Turning the Collimator**

This facility cannot be used when the collimator is used in combination with fluoroscopy equipment.

## 3.3 Auto-Filter

The auto-filter is used for the auto-filtering function that automatically selects "no filter" or three types of X-ray filter that control the characteristics of the X-rays.

When the auto-filtering function is used, the filter information can be registered or called step by step in accordance with the radiography program.

Note that the filter can be switched manually with the  (Filter selection) button even after the filter information has been called. When using RC-300, press the button on the touch panel of the X-ray tube support CH-200. For details, refer to the operation manual of the X-ray tube support CH-200.

 **Reference** CH-200 Operation Manual

For details about the filter information registration to the radiography program and its calling procedure, refer to the operation manual of the X-ray high-voltage generator that is being used in combination.



### NOTE

- The auto-filter is installed when the collimator is shipped from the factory.
- Notify your Shimadzu service representative before changing the type of X-ray filter.

### 3.3.1 Types of X-ray Filter

The material composing the X-ray filter is indicated in the display panel.

No.	Indication / Material	Application
1	Cu0 mm	No filter
2	Cu0.1 mm	The limbs, etc.
3	Cu0.2 mm	Trunk, vertebral body, etc.
4	Cu0.3 mm	Chest, abdomen, etc.

### 3.3.2 X-ray Filter Selection

---

- 1 Press the  (Filter selection) button.  
(When using RC-300, press the button on the touch panel of the X-ray tube support CH-200.)

Each time the Filter selection button is pressed, the indication in the display panel changes in the following sequence: [Cu 0 mm] → [Cu 0.1 mm] → [Cu 0.2 mm] → [Cu 0.3 mm] → [Cu 0 mm].

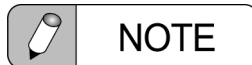

- With FLEXAVISION system using techniques that allow fluoroscopy (such as the DR technique), it is not possible to select among the X-ray filters. In order to ensure stable image quality, the setting is fixed as "Cu0 mm" for both fluoroscopy and radiography.
- With SONIALVISION G4 system using techniques that allow fluoroscopy (such as DR technique), it is possible to select the radiography filter. The information of the radiography filter appears blinking on the display panel and changes to the information of the fluoroscopy filter after 3 seconds.

# Chapter 4

## Options

### ■ Contents

4.1	Line Marker .....	38
4.2	Dose Calculation Unit .....	41
4.3	Area Dosimeter Unit .....	41
4.4	Polygonal Collimator (C-leaves) .....	42
4.5	Single-acting H Mask .....	42

## 4.1 Line Marker

The line marker is used to align the center positions of the Bucky device and the equipment, and to set the radiography position for long view radiography.



In case of laser model number LDS163LSS  
The laser beam emitted from the laser pointer (option) has a wavelength of 635 nm (nanometers) and an output of less than 1 mW and consequently is categorized as a class 2 laser by the IEC 60825-1:2014, 3rd Edition (effective on 2014-05-15).

How to identify of laser

Model Number	Class	Caution Label
LDS163LSS	2	Attached



**Do NOT look directly into the line marker.**  
Looking at it directly could cause loss of sight.



**Only in cases where the line marker is required, operate the line marker shielding slide switch on the bottom face of the collimator to open the shutter.**

- 1 Operate the line marker shielding slide switch on the bottom face of the collimator to open the shutter.

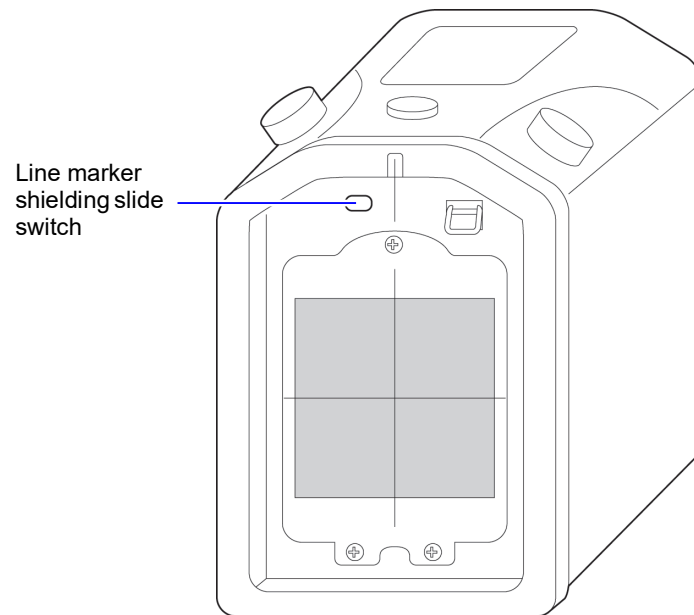

- 2 Press the lamp button.  
The lamp and line marker will light.

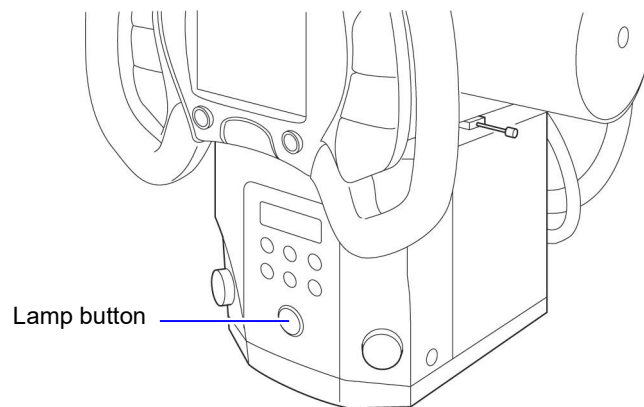

3 Press the lamp button again.

The lamp and line marker will go out.

The lamp and line marker will go out automatically after the set amount of time even if you don't press the lamp button.

 NOTE

When using R-300, the time that the lamp stays on can be set from 5 to 30 seconds at installation.

When using RC-300, the time that the lamp stays on can be set from 5 to 60 seconds at installation.

The time that the line marker stay on can be set from 5 to 30 seconds at installation.

For details on this setting, contact your Shimadzu service representative.

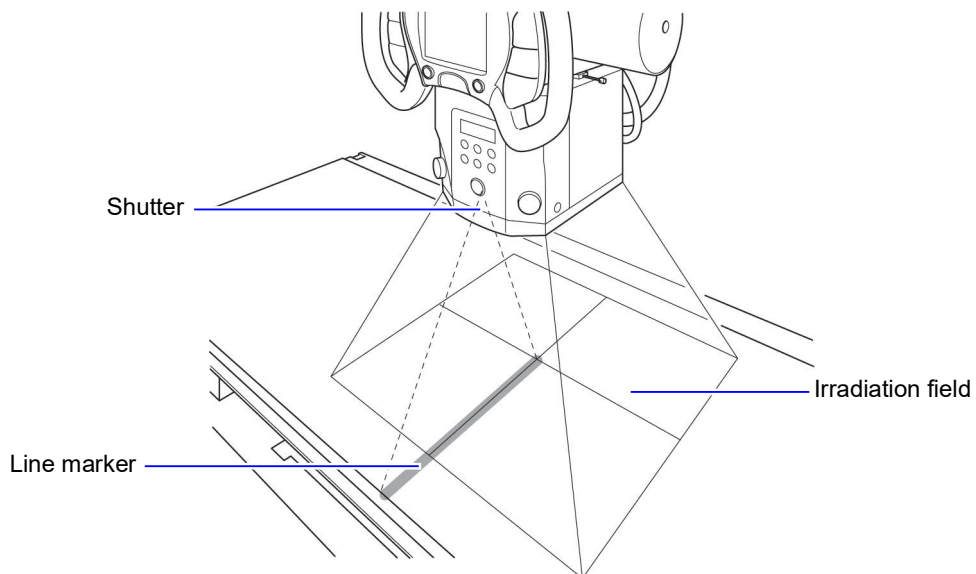

## 4.2 Dose Calculation Unit

The dose calculation unit calculates the X-ray radiation dosage applied to the patient's skin surface during radiography based on the distance between the patient's skin surface and the X-ray tube unit focal spot, and the set radiography conditions.

For details on the display for entrance dose, refer to the operation manual of the X-ray high-voltage generator that is being used in combination with the collimator.



This option is for general radiography equipment. (It cannot be used with fluoroscopy equipment.)

4

## 4.3 Area Dosimeter Unit

This is a unit used for calculating dose area product values.

For details on the display for dose area product, refer to the operation manual of the X-ray high-voltage generator that is being used in combination with the collimator.

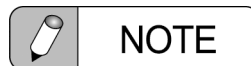

The area dosimeter must be periodically calibrated in order to maintain its precision in indicating dose area product.

For details, contact your Shimadzu service representative.

## 4.4 Polygonal Collimator (C-leaves)

Use the polygonal collimator (C-leaves) to change the shape of the irradiation field/light field from rectangle to octagon.

For details, refer to the operation manual of the system that is being used in combination with the collimator.

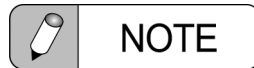

This option is for fluoroscopy equipment. (It cannot be used with general radiography equipment.)

## 4.5 Single-acting H Mask

Use the single-acting H mask to block a half of the irradiation field/light field horizontally (transversal direction of the tabletop).

For details, refer to the operation manual of the system that is being used in combination with the collimator. This page is intentionally left blank.

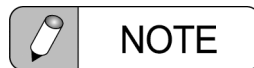

This option is for fluoroscopy equipment. (It cannot be used with general radiography equipment.)

# Chapter 5

---

## Troubleshooting

### ■ Contents

5.1	List of Error Messages .....	44
5.2	When You Suspect a Fault .....	46

## 5.1 List of Error Messages

If an error occurs, an error message appears in the relevant display location on the display panel for R-300. When using RC-300, an error message and the button are displayed on the touch panel of the X-ray tube support CH-200.

If an error message is displayed, refer to the list below and take appropriate action. In the event that the same message appears after the action has been taken, contact your Shimadzu service representative.

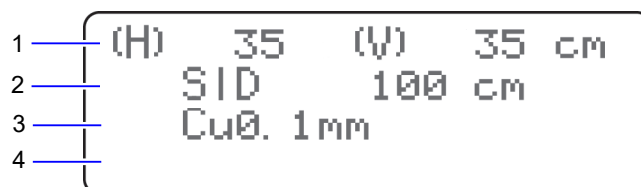



Display Location	Error Message	Cause and Corrective Action
1	ERR1	The leaf drive sensor or motor may have failed, and the leaves cannot be moved to the set position. Turn the power OFF and back ON. Note that you may be able to adjust the irradiation field after pressing the  (manual operation) button to turn the LED on.
1	ERR2	The leaf drive motor may have failed, and the leaves cannot be moved to the set position. Turn the power OFF and back ON.
3	ERR1	A sensor or motor relating to filter rotation may have failed, and the filter is not operating at the set position because rotation has stopped part way through or the wrong filter has been set. Turn the power OFF and back ON.
3	ERR2	The filter rotating motor may have failed, and the filter is not operating at the set position because rotation has stopped part way through. Turn the power OFF and back ON.
4	INITIAL INPUT ERROR	An input from the operation panel or lamp button is detected when the collimator starts up. Release your hand from the operation panel or lamp button, and turn the power OFF and back ON.
4	Lamp-ON time limited	The lamp is hot because it has been left on continuously. The lamp ON time is limited (normally about 5 to 30 seconds) because it needs cooling. After the elapse of a certain period of time, the message disappears and the lamp can be turned on again. Unnecessary lighting of the lamp and temperature rises can be prevented by reducing the time that the lamp stays on. If an error message appears frequently, consult your Shimadzu service representative and set the time that the lamp stays on in accordance with system usage.

Display Location	Error Message	Cause and Corrective Action
4	ERR1	The sensor or motor driving polygonal collimator (C-leaves)/single-acting H mask may have failed, and the leaves cannot be moved to the set position. Turn the power OFF and back ON.
4	ERR2	The motor driving polygonal collimator (C-leaves)/single-acting H mask may have failed, and the leaves cannot be moved to the set position. Turn the power OFF and back ON.

## 5.2 When You Suspect a Fault

This section explains the abnormalities that may occur while you are using the collimator.

If an error message appears on the display panel, see "5.1 List of Error Messages" P.44.

Problem	Cause and Corrective Action
A burning smell	Parts inside the collimator may have failed. Turn the power OFF immediately and contact your Shimadzu service representative.
The lamp does not light.	The lamp circuit may have failed or the lamp may have blown. Turn the power OFF and back ON. If the lamp still does not light contact your Shimadzu service representative.
The lamp doesn't go out even after the set amount of time (Max. 30 seconds).	Parts inside the collimator may have failed. Turn the power OFF and back ON. If the lamp still doesn't go out contact your Shimadzu service representative.
The irradiation field cannot be adjusted.	Press the  (manual operation) button (the LED will light) and check if adjustment is possible by using the irradiation field adjustment knobs. When using RC-300, press the button on the touch panel of the X-ray tube support CH-200. If adjustment is possible: Check if the appropriate technique is being used. If it is not, change the technique. If adjustment is not possible: Turn the power OFF and back ON. If adjustment is still not possible contact your Shimadzu service representative.
The irradiation field will not fully close although the size indicated for it is 0 mm.	Turn the power OFF and back ON. If the irradiation field still won't fully close, contact your Shimadzu service representative.
An abnormal noise is heard when the irradiation field is fully closed or fully open.	The motor may have failed. Turn the power OFF and back ON. If the abnormal noise persists, contact your Shimadzu service representative.
There is something wrong with the display or there is no display.	Parts inside the collimator may have failed. Turn the power OFF and back ON. If there is still something wrong with the display or there is no display, contact your Shimadzu service representative.
The SID indication remains on the display panel even after the irradiation field size is set in the radiography condition.	Check if the  (manual operation) button is pressed. When using RC-300, check the button on the touch panel of the X-ray tube support CH-200. If the  (manual operation) button is not pressed (the LED is off) but the SID indication remains, the communication function with the combined radiographic device may have failed. Turn the power OFF and back ON. If the SID indication is still displayed contact your Shimadzu service representative.

# Chapter 6

---

## Maintenance

### ■ Contents

6.1	Maintenance Check .....	50
6.2	Daily Inspections (Inspections Carried Out by the User) .....	51
6.3	Periodical Inspection .....	57
6.4	Maintenance Parts List .....	58

## 6.1 Maintenance Check

- The equipment is a precision medical device. In order to continue using it for a long time, inspections must be carried out before and after using it in routine use, in addition to the periodical inspections.
- By carrying out these routine and periodical inspections correctly, the occurrence of problems with the collimator can be prevented in advance, and the collimator can be used correctly and safely. It also means that sudden stoppages of operation are avoided.
- In order to maintain the safety and performance of the equipment and the radiography system, be sure to carry out maintenance inspections including inspection of the cables. If you do not, the life of the collimator may be shortened and it could lead to serious failures and impairment of health.
- The maintenance check not only includes daily and periodical checks, but also covers replacement of consumable parts and periodic replacement of parts.
- A part of the periodical checks and the replacement of parts require knowledge and skills sufficient to use special tools or deal with dangerous situations in the process.
- For more information on periodical checks and periodic replacement of parts, contact your Shimadzu service representative.



**If any abnormality is found during the maintenance check, stop using the equipment and contact your Shimadzu service representative.**

When a user performs the maintenance check for himself or herself, please keep in mind his or her own safety.

Shimadzu shall not be liable for any damage resulting from the checks other than those by Shimadzu or Shimadzu representative.

## 6.2 Daily Inspections (Inspections Carried Out by the User)

Carry out the following inspection before starting work, and if there is any abnormality contact your Shimadzu service representative or the qualified personnel approved by them.

### 6.2.1 Checklist for Daily Inspection

Date of inspection: \_\_\_\_\_

Inspected by: \_\_\_\_\_

Check points	Inspection points
Mount for the X-ray tube unit	<ul style="list-style-type: none"> <li>Is there any looseness or play in the mount between the collimator and the X-ray tube unit?</li> </ul>
Surroundings of the collimator and system	<ul style="list-style-type: none"> <li>Is there any rust on the moving parts of the collimator or system?</li> <li>Have any pieces of metal, etc., been dropped around the collimator or system?</li> </ul>
Cables	<ul style="list-style-type: none"> <li>Is there any damage or abnormality?</li> </ul>
Appearance	<ul style="list-style-type: none"> <li>Is there any adhering contrast medium, water or chemicals?</li> <li>Any breakage (dents, fractures, etc.) on the cover?</li> </ul>
Illumination lamp	<ul style="list-style-type: none"> <li>Does illumination lamp turn on?</li> <li>Light field is bright?</li> </ul>
Aperture	<ul style="list-style-type: none"> <li>Do the leaves move normally?</li> </ul>
Other	<ul style="list-style-type: none"> <li>Any bad smells or abnormal sounds when power is on?</li> </ul>
Privacy shutter (Only when the camera option is included)	<ul style="list-style-type: none"> <li>Is there any hindrance during the opening/closing operation?</li> <li>Is there any wear debris or other object near the shutter?</li> </ul>

## 6.2.2 Checking Light Field

- 1 Load an FPD, cassette, or CR cassette into the radiography table.
- 2 Adjust the position of the X-ray tube unit.  
Arrange the X-ray tube unit to create an SID of 100 cm for general radiography equipment, and an SID of 110 cm for fluoroscopy equipment.
- 3 By operating the H-leaves and V-leaves with the irradiation field adjustment knobs, set an irradiation field of 35 × 35 cm (14 × 14 inches).
- 4 Press the lamp button to turn on the lamp.
- 5 Check the size of the light field.  
Confirm that the size of the light field satisfies the dimensions in the table below.
- 6 Change the SID on the X-ray tube unit to check if the light field is adjusted accordingly.  
Change the SID to 150 cm, and confirm that the size of the light field is adjusted to the dimensions in the table below.

### ■ General Radiography Equipment

Item	Light field at SID 100 cm	Light field at SID 150 cm
When checking on radiography table	322±20 mm	331±20 mm
When checking on radiography stand	336±20 mm	340±20 mm

### ■ Fluoroscopy Equipment

Light field at SID 110 cm	Light field at SID 150 cm
330±20 mm	336±20 mm

## 6.2.3 Checking the Warning and Caution Labels

Periodically (once a year) inspect the labels attached on the equipment.

If any label is peeled or unreadable by stain or scratch, contact your Shimadzu service representative for replacement of a new one.

 Reference "Warning and Caution Labels" P.xxiii

## 6.2.4 Cleaning and Disinfection



**Be sure to turn the equipment power OFF before cleaning and disinfecting the equipment.**

Otherwise, a malfunction may occur in the equipment, or the equipment may operate in an unintended way.

Also, thoroughly ventilate the room before turning ON the power after disinfection work is complete.



**Be sure to clean and disinfect the equipment periodically.**

Cleaning and disinfection is very important to ensure that the equipment can be used hygienically and safely. Strictly follow the methods prescribed.



**Be sure to clean the equipment frequently and after each patient use.**

While doing so, do NOT directly apply or spray any disinfectant, cleaner, or water onto the equipment. Wipe down all contact surfaces using a cloth moistened with an appropriate disinfectant or cleaner. Make sure the cloth is NOT too wet. If it is, liquid may enter into system electronics, causing failure or malfunction.



**Use the following disinfectants (intermediate level disinfectant):**

- Chlorine disinfectants  
Sodium dichloroisocyanurate solution (1 % maximum)  
Sodium hypochlorite solution (1 % maximum)
- Alcohol disinfectants  
Commercially available isopropyl alcohol solution (Up to 99 wt% can be used)
- Rubbing alcohol  
(76.9 - 81.4 vol% Ethanol, Isopropyl alcohol as an additive)

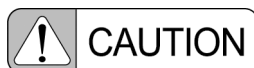

**Do NOT use the following disinfectants:**

If any of the following disinfectants are applied, the equipment performance and safety cannot be guaranteed.

- Disinfectants that corrode metals, plastics, rubber, or paint
- Disinfectants unsuitable for metals, plastics, rubber, or paint
- Spray-gas type disinfectants
- Volatile disinfectants
- Disinfectants that may enter the equipment

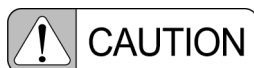

**Use disinfectants at a minimum.**

Repeated disinfection over a long time may lead to discoloring and cracking on the equipment surface, and deterioration of rubber and plastic. If any abnormality is found on the equipment after disinfection, stop using the equipment immediately. Contact your Shimadzu service representative for repair.

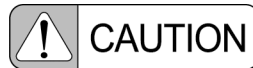

**Do NOT use an organic solvent.**

Organic solvents may change the surface color. If an organic solvent adheres to the surface, wipe it out immediately.

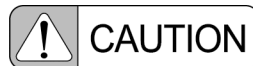

**When disinfecting unpainted metals, do NOT use chlorine-based disinfectants.**

Chlorine-based disinfectants may corrode the surface of the equipment. If chlorine-based disinfectants adhere to the surface, wipe them off immediately.



**When disinfecting resin parts such as reticule of the collimator, do NOT use rubbing alcohol.**

Rubbing alcohol may lead to deformation or crack of resin parts such as reticule of the collimator. Wipe it off immediately if it adheres to the reticule of the collimator.



**When cleaning resin parts such as reticule of the collimator, use cloth lightly moistened, not soaked, with cold or warm water mixed with neutral detergent that does not include organic solvent.**

Rubbing alcohol, organic solvents or non-neutral detergents may lead to deformation or crack of resin parts such as reticule of the collimator. Wipe them off immediately if they adhere to the reticule of the collimator.

On completing the work, check the following points before switching the power ON again.

- There must be no water or disinfectant adhering to the equipment.
- The tools used in cleaning and disinfecting work must be tidied away.

 Reference "3.1 Turning the Power ON/OFF" P.22



**When turning the power ON after cleaning, make sure the examination room is properly ventilated.**

Turning the power ON while any flammable gas remains in the examination room could lead to fire, smoke, explosion or electrocution.

## 6.3 Periodical Inspection

Even without any problem in daily inspection, the following items should be inspected periodically.



**Be sure to perform periodic inspection (yearly).**

Failure to do this may cause serious accidents or significantly shorten the lifetime of the equipment.

Periodic inspections mainly check the equipment performance and the internal mechanisms. The inspections require good knowledge of the internal mechanisms and can also be dangerous. Contact your Shimadzu service representative to request a periodic inspection. It is recommended to conduct periodic inspections yearly. A fee is charged for periodic inspections after expiry of the warranty periods.

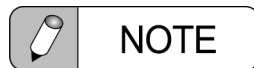

If necessary, service engineers will contact the manufacturer of the equipment to get information about repairing.

Item	Inspection points
Wire ropes	<ul style="list-style-type: none"> <li>• Are there any broken wires?</li> <li>• Are there abnormalities of the fastening parts?</li> </ul>
Mount for the X-ray tube unit	<ul style="list-style-type: none"> <li>• Are any of the clamping screws loose?</li> </ul>

## 6.4 Maintenance Parts List

To maintain the performance of the system, the following parts need replacing at regular intervals. When replacing them, use the genuine parts and contact your Shimadzu service representative.

Parts Name	Parts Number	Recommended exchange time
Halogen Lamp *	062-65012-03	1 year

\* : Not required when using an LED lamp.

Prepare some locking mechanism to keep a off status of Molded Case Circuit Breaker. This is required for the service representative to disconnect the instrument from the main power supply when performing repairs..

# Chapter 7

---

## Specifications

### ■ Contents

7.1	Environmental Conditions of EMC (Electromagnetic Compatibility) .....	60
7.2	Specifications .....	64
7.3	Labels .....	67
7.4	Statement of Compliance [For Europe] .....	72
7.5	Statement of Compliance with Standards .....	73
7.6	Manufacturer Information .....	73
7.7	Product Safety .....	74

## 7.1 Environmental Conditions of EMC (Electromagnetic Compatibility)

The equipment satisfies the EMC (Electromagnetic Compatibility) standard below:

IEC 60601-1-2:2014+A1:2020



**The equipment is suitable for installing at a professional healthcare facility environment except below:**

- Medical treatment areas with high-powered medical electrical equipment (High frequency surgical equipment, short-wave therapy equipment)
- Inside the radio frequency shielded room of an MRI.

### ■ Classification of EMI in Accordance with IEC 60601-1-2:2014+A1:2020

Group 1, Class A

The system uses radio-frequency energy only for its internal function and is not intended to deliver energy to the patient. But little leakage radio-frequency energy does harm to high-sensitive equipment.

The system main power line in the clinical site should be connected to the domestic power sources which are separated from the public main network.

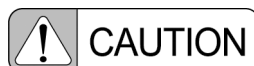

**For replacement parts of internal components, make sure to apply the cables supplied by Shimadzu.**

The use of non-cable devices, accessories, or cables other than those sold by Shimadzu as replacement parts for the internal components may result in increased emissions or decreased immunity of the equipment.

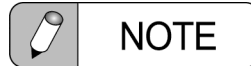

The emissions characteristics of the system make it suitable for use in industrial areas and hospitals (CISPR 11 class A).

If it is used in a residential environment (for which CISPR 11 class B is normally required) the system might not offer adequate protection to radio-frequency communication services.

The user might need to take mitigation measures, such as relocating or re-orienting the system.

### **■ Performance to Be EMC Immunity Tested (Essential performance)**

Essential performances of this equipment are as followings;

- Adjustment of X-ray field

If an essential performance of this equipment is degraded or lost due to electromagnetic disturbances, the following may occur.

- X-ray irradiation field exceeds the accuracy specified in IEC 60601-1-3.

## Guidance and Manufacturer's Declaration - Electromagnetic Immunity

Immunity test	EN 60601/IEC 60601 test level	Compliance level
Electrostatic discharge (ESD) EN 61000-4-2/ IEC 61000-4-2	±8 kV Contact ±2 kV, ±4 kV, ±8 kV, ±15 kV Air	±8 kV Contact ±2 kV, ±4 kV, ±8 kV, ±15 kV Air
Electrical fast transient/burst EN 61000-4-4/ IEC 61000-4-4	±2 kV for power supply lines ±1 kV for input/output lines	±2 kV for power supply lines ±1 kV for input/output lines
Surge EN 61000-4-5/ IEC 61000-4-5	±0.5 kV, ±1 kV line(s) to line(s) ±0.5 kV, ±1 kV, ±2 kV line(s) to earth	±0.5 kV, ±1 kV line(s) to line(s) ±0.5 kV, ±1 kV, ±2 kV line(s) to earth
Voltage dips, short interruptions and voltage variations on power supply input lines EN 61000-4-11/ IEC 61000-4-11	N/A	N/A
Power frequency (50/60 Hz) magnetic field EN 61000-4-8/ IEC 61000-4-8	30 A/m	30 A/m
Conducted RF EN 61000-4-6/ IEC 61000-4-6	150 kHz to 80 MHz 3 Vrms (outside ISM bands * <sup>1</sup> ) 6 Vrms (in ISM bands) (1 kHz, AM80 %)	150 kHz to 80 MHz 3 Vrms (outside ISM bands) 6 Vrms (in ISM bands) (1 kHz, AM80 %)
Radiated RF EN 61000-4-3/ IEC 61000-4-3	80 MHz to 2.7 GHz 3 V/m (1 kHz, AM80 %)  Enclosure port immunity to RF wireless communications equipment Refer to the <a href="#">Table 7.1</a> .	80 MHz to 2.7 GHz 3 V/m (1 kHz, AM80 %)  Enclosure port immunity to RF wireless communications equipment Refer to the <a href="#">Table 7.1</a> .
Proximity magnetic fields EN 61000-4-39/ IEC 61000-4-39	134.2 kHz 65 A/m (Pulse modulation 2.1 kHz, 50 % duty cycle square wave signal)	134.2 kHz 65 A/m (Pulse modulation 2.1 kHz, 50 % duty cycle square wave signal)
	13.56 MHz 7.5 A/m (Pulse modulation 50 kHz, 50 % duty cycle square wave signal)	13.56 MHz 7.5 A/m (Pulse modulation 50 kHz, 50 % duty cycle square wave signal)
<p>Note</p> <p>*1: The ISM bands between 150 kHz and 80 MHz are 6.765 to 6.795 MHz; 13.553 MHz to 13.567 MHz; 26.957 MHz to 27.283 MHz; and 40.66 MHz to 40.70 MHz.</p>		

## 7.1 Environmental Conditions of EMC (Electromagnetic Compatibility)

Table 7.1 Test specifications for ENCLOSURE PORT IMMUNITY to RF Wireless Communications Equipment

Test Frequency [MHz]	Modulation	EN 60601-1/ IEC 60601-1 test level (V/m)	Compliance level (V/m)
385	Pulse modulation: 18 Hz <sup>*1</sup>	27	19
450	FM ±5 kHz deviation: 1 kHz sine <sup>*2</sup>	28	28
710	Pulse modulation: 217 Hz <sup>*1</sup>	9	9
745			
780			
810	Pulse modulation: 18 Hz <sup>*1</sup>	28	28
870			
930			
1462	Pulse modulation: 217 Hz <sup>*1</sup>	10	10
1720	Pulse modulation: 217 Hz <sup>*1</sup>	28	19
1845			
1970			
2450	Pulse modulation: 217 Hz <sup>*1</sup>	28	19
5240	Pulse modulation: 217 Hz <sup>*1</sup>	9	9
5500			
5785			

\*1: The carrier shall be modulated using a 50 % duty cycle square wave signal.

\*2: As an alternative to FM modulation, the carrier may be pulse modulated using a 50 % duty cycle square wave signal at 18 Hz. While it does not represent actual modulation, it would be worst case.

## 7.2 Specifications

### 7.2.1 R-300

Item		Description
Max. voltage used for applicable X-ray tube		150 kV
Irradiation field	Rectangular irradiation field H-leaves and V-leaves (SID 100 cm)	Max. : 523 × 523 mm (450 × 450 mm, when polygonal collimator (C-leaves) and single-acting H mask are built in) Min. : 0 × 0 mm Shape formed by overlapping of leaves
Light field	Average illumination	160 lx or more (when SID is 100 cm)
	Time lamp stays on	Continuously for 5 to 30 seconds (automatically turns off, time set at installation)
	Lamp	Halogen lamp (JM 12V 106 W 5 H) or LED lamp
	Adjustment mechanism	Provided
	Discrepancy between light field and actual irradiation field	Within 2% of the SID (adjusted on shipment from the factory)
Filtration	Inherent filtration	1.1 mm Al at 75 kV/HVL 2.7 mm Al
	Auto-filter	Cu 0, 0.1, 0.2, 0.3 mm The X-ray filter can be switched in accordance with the radiography conditions set on the X-ray high-voltage generator.
Pb equivalency of leaves	Shielding leaves (H-leaves and V-leaves)	3 mm Pb eq.
	Middle leaves	2 mm Pb eq.
Leaves driving method		Stepping motor drive
Distance between the focus and fitting face		60 mm
External Dimensions		231 (W) × 317 (L) × 259 (H) mm
Mass		Approx. 10 kg
Power Supply		24 VDC, 150 VA (without polygonal collimator (C-leaves)) (Supplied from Ceiling X-ray Tube Support) 240 VA (with polygonal collimator (C-leaves) or when combined with SONIALVISION G4 system) (Supplied from G4 system)
Turning Mechanism		±45°

## 7.2.2 RC-300

Item		Description
Max. voltage used for applicable X-ray tube		150 kV
Irradiation field	Rectangular irradiation field H-leaves and V-leaves (SID 100 cm)	Max. : 523 × 523 mm (450 × 450 mm, when polygonal collimator (C-leaves) and single-acting H mask are built in) Min. : 0 × 0 mm Shape formed by overlapping of leaves
Light field	Average illumination	160 lx or more (when SID is 100 cm)
	Time lamp stays on	Continuously for 5 to 60 seconds (automatically turns off, time set at installation)
	Lamp	LED lamp
	Adjustment mechanism	Provided
	Discrepancy between light field and actual irradiation field	Within 2% of the SID (adjusted on shipment from the factory)
Filtration	Inherent filtration	1.1 mm Al at 75 kV/HVL 2.7 mm Al
	Auto-filter	Cu 0, 0.1, 0.2, 0.3 mm The X-ray filter can be switched in accordance with the radiography conditions set on the X-ray high-voltage generator.
Pb equivalency of leaves	Shielding leaves (H-leaves and V-leaves)	3 mm Pb eq.
	Middle leaves	2 mm Pb eq.
Leaves driving method		Stepping motor drive
Distance between the focus and fitting face		60 mm
External Dimensions		231 (W) × 343 (L) × 280 (H) mm
Mass		Approx. 10 kg
Power Supply		24 VDC, 150 VA (without polygonal collimator (C-leaves))
Turning Mechanism		±45°

### 7.2.3 Options

---

Name	Description	See
Detent	Allows easy positioning and rotation of the collimator with a click action every 45 degrees.	P.28
Line marker	Used to align the center positions of the Bucky device and the equipment, and to set the radiography position for long view radiography.	P.38
Dose calculation unit	Calculates the X-ray radiation dosage applied to the patient's skin surface during radiography based on the distance between the patient's skin surface and the X-ray tube unit focal spot, and the set radiography conditions.	P.41
Area Dosimeter Unit	This is a unit used for calculating dose area product values.	P.41
Polygonal Collimator (C-leaves)	Use the polygonal collimator (C-leaves) to change the shape of the irradiation field/light field from rectangle to octagon.	P.42
Single-acting H Mask	Use the single-acting H mask to block a half of the irradiation field/light field horizontally (transversal direction of the tabletop).	P.42

# 7.3 Labels

## 7.3.1 R-300

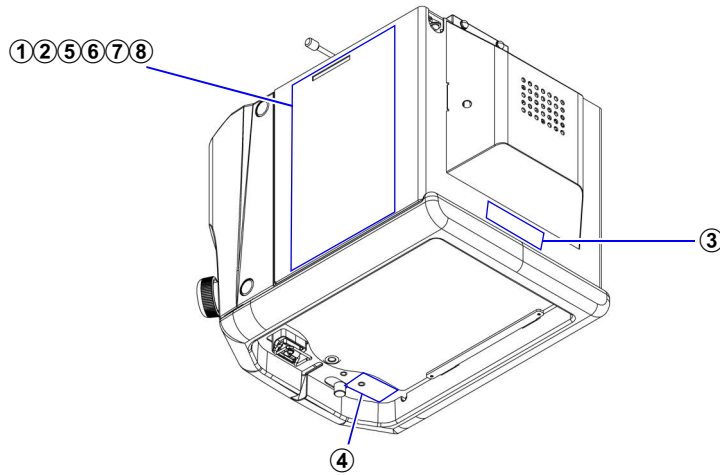

### Name Plate

#### ① Name plate

一般的名称	モータ付自動絞りX線診断装置用コリメータ		
MODEL	COLLIMATOR TYPE R-300		
販売名	自動可動絞り R-300		
医療機器の別	一般医療機器	特管	XXXX
PN / SN	566-17970-X0 / [SN]		
V. VA	24, 150		
MAX. TUBE kVp	150		
AL. EQ.	1.1 mm at 75 kV		
PROTECTION	CLASS I		
MANUFACTURED	2020-03-01	Made in Japan	
製造販売届出番号	26B1X00003000223	566-25407-X0	
 <b>株式会社 島津製作所</b> 604-8511 京都市中京区西ノ京桑原町1 <b>SHIMADZU CORPORATION</b> 1, Nishinkyo-Kumabaracho, Nakagyo-ku, Kyoto 604-8511, Japan			

7

### Warning Labels

#### ② Warning label

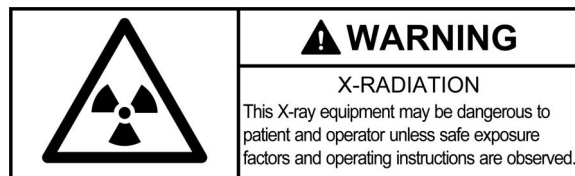

#### ③ Caution label (for Halogen Lamp Type)



## 7 Specifications

- ④ Caution label (option: Only if laser model number is LDS163LSS.)



### Others

- ⑤ Label, cTÜVus mark (For USA)

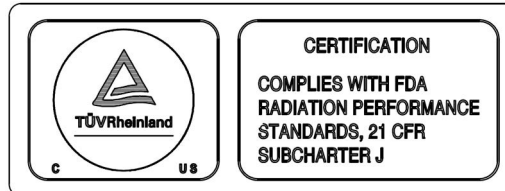

- ⑤ Label, CE (For CE)

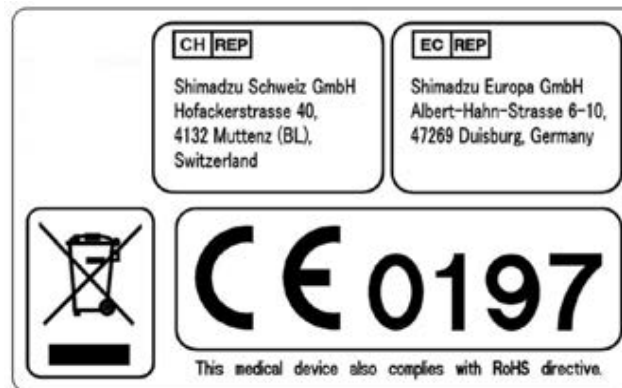

- ⑥ Refer to operation manual



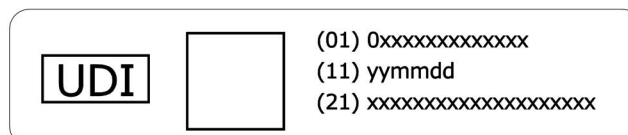

- ⑦ UDI Label

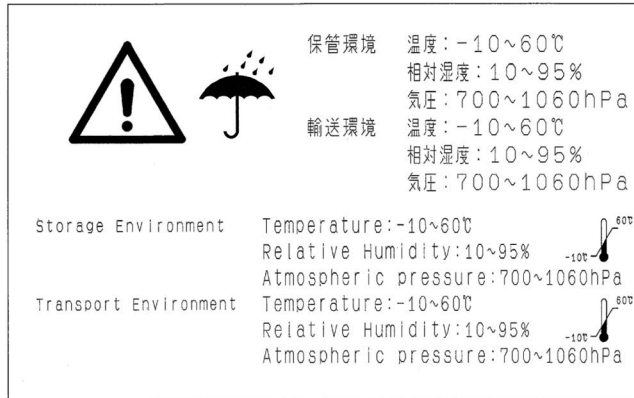

### Package for Transportation

The following shows the label on the package for transportation, describing about storage environment and transport environment.



Symbol	Location	Meaning
	Package	Keep away from rain in during transport.

7.3.2 RC-300

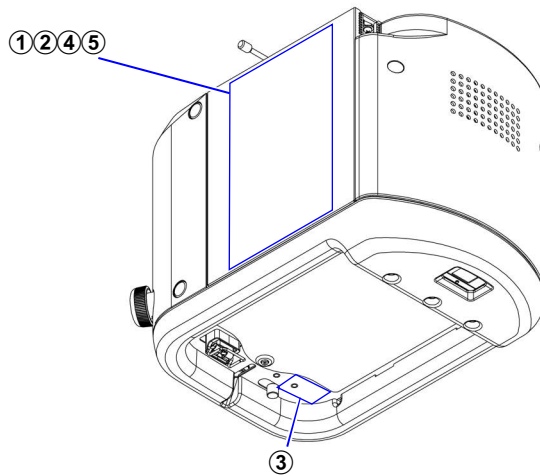

**Name Plate (Identification label)**

① Name plate

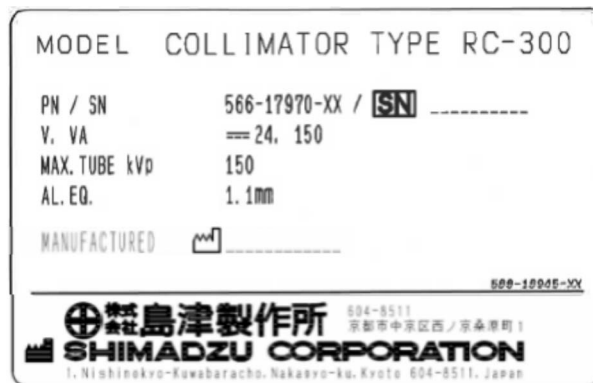

**Warning Labels**

② Warning label

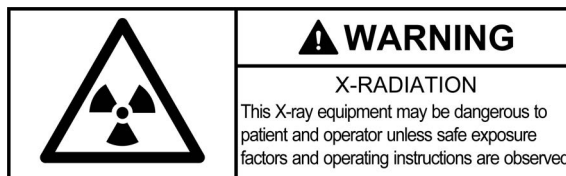

③ Caution label (option: Only if laser model number is LDS163LSS.)



**Others**

④ Refer to operation manual



⑤ UDI Label

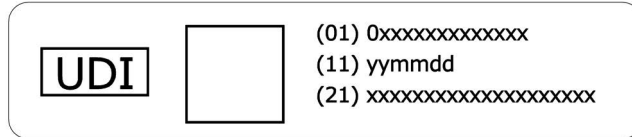

**Package for Transportation**

The following shows the label on the package for transportation, describing about storage environment and transport environment.

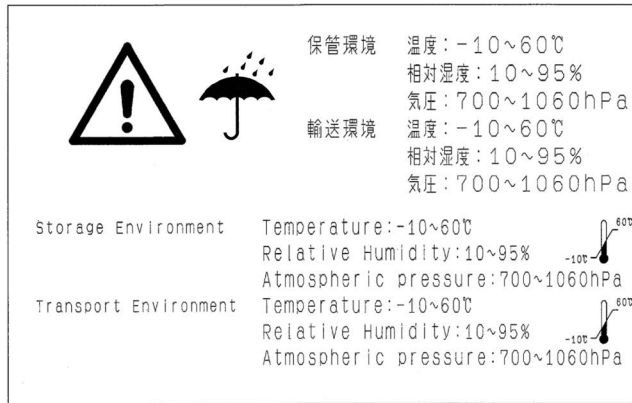

Symbol	Location	Meaning
	Package	Keep away from rain in during transport.

## 7.4 Statement of Compliance [For Europe]

### 7.4.1 Regulatory Information

---

For Europe:

The product complies with the requirement of the Medical Device Directive 93/42/EEC and RoHS Directive 2011/65/EU.

Product Name: COLLIMATOR TYPE R-300

Manufacturer: SHIMADZU CORPORATION  
Medical Systems Division  
  
1, NISHINOKYO-KUWABARACHO,  
NAKAGYO-KU, KYOTO, 604-8511, JAPAN

Authorized Representative / Importer: Shimadzu Europa GmbH  
Albert-Hahn-Strasse 6-10,  
47269 Duisburg, Germany

### 7.4.2 Company's Quality System

---

• R-300

The company's quality management system complies with the requirements of Annex II, excluding Section 4 of the MDD 93/42/EEC, which is certified by TÜV Rheinland LGA Products GmbH (Notified under No.0197)

• RC-300

For details on description for "RADspeed Pro" system, refer to the operation manual for RADspeed Pro.

### 7.4.3 International Standards

---

This equipment conforms the following international standards.

- IEC 60601-1:2005+A1:2012+A2:2020 / EN 60601-1:2006+A1:2013+A12:2014+A2:2021
- IEC 60601-1-2:2014+A1:2020 / EN 60601-1-2:2015+A1:2021
- IEC 60601-1-3:2008+A1:2013+A2:2021 / EN 60601-1-3:2008+A2:2021
- IEC 60601-1-6:2010+A1:2013+A2:2020 / EN 60601-1-6:2010+A1:2015+A2:2021
- IEC 60601-2-54:2022 / EN IEC 60601-2-54:2024
- ISO 10993-1:2018 Corrected version / EN ISO 10993-1:2020
- ISO 14971:2019 / EN ISO 14971:2019+A11:2021
- IEC 62304:2006+A1:2015 / EN 62304:2006+A1:2015
- IEC 62366-1:2015+A1:2020 / EN 62366-1:2015+A1:2020
- ISO 15223-1:2021 / EN ISO 15223-1:2021
- EN 1041:2008+A1:2013

## 7.5 Statement of Compliance with Standards

- X-RAY EQUIPMENT for RADIOGRAPHY and RADIOSCOPY ...  
COLLIMATOR TYPE R-300 IEC 60601-2-54:2022
- X-RAY EQUIPMENT for RADIOGRAPHY and RADIOSCOPY ...  
COLLIMATOR TYPE R-300 EN IEC 60601-2-54:2024

## 7.6 Manufacturer Information

Manufacturer: SHIMADZU CORPORATION  
Medical Systems Division

Address: 1, NISHINOKYO-KUWABARACHO,  
NAKAGYO-KU, KYOTO, 604-8511, JAPAN

## 7.7 Product Safety



Do NOT operate this unit if there is any uncertainty as to the proper functioning of the system. Refer all servicing to qualified service personnel.



This equipment must be grounded. To minimize the shock hazard, make sure of performing the ground work according to Installation Manual.



The operator must set the focal spot to skin distance as large as possible in order to keep the absorbed dose to the patient as low as reasonably achievable.

---

# Appendix

## Check List for Troubleshooting

---

Fill following blanks and contact your Shimadzu service representative.

Hospital:

---

Phone:

---

FAX:

---

Serial Number:

---

Date of Installation:

Item	Check
<input type="checkbox"/> Did the malfunction injure anyone?	
<input type="checkbox"/> When did the malfunction occur?	
<input type="checkbox"/> Did the system malfunction suddenly? Were there any indications of a problem beforehand?	
<input type="checkbox"/> Was there a power failure or thunderbolt when the malfunction occurred?	
<input type="checkbox"/> Has the system come in contact with moisture?	
<input type="checkbox"/> Has the unit been subjected to a strong impact?	
<input type="checkbox"/> How many patients per day are diagnosed using the malfunctioning unit?	
<input type="checkbox"/> When was the last periodic inspection?	

## Safety Instruction Registry

Hospital	<input type="checkbox"/> Name	
	<input type="checkbox"/> Phone	
	<input type="checkbox"/> Extension number	
	<input type="checkbox"/> FAX	
	<input type="checkbox"/> Address	
	<input type="checkbox"/> Room number	
Equipment	<input type="checkbox"/> Name	
	<input type="checkbox"/> Serial number	
	<input type="checkbox"/> Date of Installation	
Instructor	<input type="checkbox"/> Affiliation	
	<input type="checkbox"/> Phone	
	<input type="checkbox"/> FAX	

Date	Description	This equipment's maintenance and operation staff	Instructor
		Signature	Signature

- At the time of installation or when changing the designated operator, your Shimadzu service representative will explain the safety instructions described in this manual to the maintenance and operation staff, and record the information.
- This manual is important. We request all maintenance personnel to keep it in a safe place close to the equipment.

This page is intentionally left blank.