



VOTRE PARTENAIRE SANTÉ & ENVIRONNEMENT

ECODAS SYSTEM

USER HANDBOOK

T150/T300/T700/T1000/T2000



ASME



CE → According to the directive N° 2014/68/UE of 15 May 2014
Machine → According to the directive N° 2006/42/CE of 9 June 2006

Original instructions

ECODAS S.A.S.

"ECODAS" Process: Shredding and Sterilization of Medical waste

28 Rue Sébastopol
59100 ROUBAIX France

Tel: + 33 3.20.70.98.65 – Fax: +33 3.20.36.28.05

E-mail : contact@ecodas.com

Internet: www.ecodas.com

Ownership of this document remains with ECODAS Ltd.

1.	OPERATION MANUAL	4
1.1	INTRODUCTION	5
1.1.1	MANUAL OBJECTIVES	5
1.1.2	WASTE TYPE BE STERILIZED	5
1.1.3	TREATMENT EFFICIENCY	5
1.1.4	BRIEF DESCRIPTION OF THE MACHINE	7
1.1.4.1	UPPER CHAMBER	7
1.1.4.2	SHREDDER	7
1.1.4.3	LOWER CHAMBER	7
1.1.4.4	COLLECTION OF THE STERILIZED WASTE	7
1.1.4.5	CONTROL PANEL	7
1.1.5	TECHNICAL DESCRIPTION	8
1.1.5.1	SYNOPTICS	8
1.1.5.2	DESCRIPTION OF MECHANICAL COMPONENTS	12
1.1.5.3	TECHNICAL SPECIFICATIONS	18
1.1.5.4	DIMENSIONS, FOOTPRINT	21
1.1.6	CERTIFICATIONS	25
1.1.7	SOUND LEVEL	29
1.1.8	LIFT TEST CERTIFICATE	30
1.2	SAFETY INSTRUCTIONS - ACCIDENT PREVENTION	31
1.2.1	TREATMENT VESSEL	33
1.2.2	SHREDDER	33
1.3	DESCRIPTION DU CYCLE DE FONCTIONNEMENT	34
1.4	OPERATING THE MACHINE	39
1.4.1	OPERATOR MACHINE INTERFACE	39
1.4.1.1	INTRODUCTION	39
1.4.1.2	SCREEN OVERVIEW	39
1.4.1.3	DEFAULT SCREEN AT START UP	41
1.4.1.4	LOGIN WITH A USERNAME AND A PASSWORD	42
1.4.1.5	STARTING THE STERILIZATION CYCLE	43
1.4.1.6	RUNNING THE SAFETY CYCLE	45
1.4.1.7	RUNNING THE CLEANING CYCLE	47
1.4.1.8	RESUME A CYCLE AFTER AN EMERGENCY STOPPING OR A POWER FAILURE	49
1.4.1.9	ILLUSTRATION OF A CYCLE IN PROGRESS	50
1.4.1.10	CYCLE INFORMATION	52
1.4.1.11	PRESSURE AND TEMPERATURE GRAPHS	53
1.4.1.12	ALARMS INFORMATION	54
1.4.1.13	SETTING DATE AND TIME	55
1.4.1.14	MANUAL CONTROL	56
1.4.2	REPORTS TREATMENT CYCLE	58
1.5	BASKET AND ITS LOCATION TO CARRY OUT THE BIOLOGICAL TEST	59
2.	OPERATION	60
2.1	START AUTOMATIC MODE	60
2.1.1	LOADING	61
2.1.1.1	CYCLE RUNNING	61
2.1.2	UNLOADING	62
2.1.3	STOP THE MACHINE	63
2.1.4	FUNCTIONAL CONTROL	63
2.1.5	DISPLAY MESSAGES	65
2.2	MACHINE SAFETY	66
2.2.1	UNLOCKING COVERS	66
2.2.2	SEALING OF THE MACHINE	66
2.2.3	STEAM PRESSURIZATION/OVERPRESSURE	67
2.2.4	STOP AND CONTROL	67
2.2.5	INTERVENTION IN THE MACHINE	67
2.2.6	INTERVENTION DURING A SHREDDER BLOCKAGE	69
3.	MAINTENANCE	70
3.1	CONSEILS	ERREUR ! SIGNET NON DEFINI.
3.2	PREVENTIVE MAINTENANCE	72
3.2.1	ORDERS TO RESPECT	72
3.2.2	PREVENTIVE MAINTENANCE SCHEDULE	73

4.	TROUBLESHOOTING	74
4.1	DISPLAY ALARM MESSAGES.....	75
4.1.1	SUMMARY TABLE.....	75
4.1.2	ALARM INSTRUCTIONS.....	77
4.2	PNEUMATIC ACTUATORS FAULTS.....	113
4.3	ELECTRICAL PROTECTIONS OF THE MACHINE.....	114
4.4	ALARM AND LIGHTS	115
5.	RECOVERY – PRODUCT DISPOSAL	116
6.	QUICK START.....	117
6.1	BOILER START.....	117
6.2	COMPRESSOR START	122
6.3	MACHINE START	123

1. OPERATION MANUAL

1.1 INTRODUCTION

1.1.1 MANUAL OBJECTIVES

This manual has been designed and introduced to be thoroughly read, understood, and respected on all levels by the holders and users of the machine.

ATTENTION: To ensure maximum safety and to maintain the life of the machine, follow the directions described in this manual. The expected results and the equipment good reliability depend in part on the co-operation and the vigilance of the users.

ECODAS SAS assumes no responsibility for the use and/or the reliability of its equipment if the instructions furnished in these documents are not followed. A hazard of personal injury and/or equipment damage exists if provided information in this manual is ignored.

Reproduction of the contents of this manual, in whole or in part, without written permission of ECODAS SAS is prohibited.

1.1.2 WASTE TYPE BE STERILIZED

ECODAS SYSTEM has been conceived for decontamination of medical waste such as defined in local regulations.

Radioactive and chemical products are not to be treated by ECODAS SYSTEM.

The ECODAS SYSTEM installation, maintenance, service, and repair can only be performed by authorized and trained personal who are familiar with this equipment and aware of its risks (vat under pressure and shredder).

ATTENTION: Changes or modifications, even temporary, executed without the manufacturer written agreement release ECODAS SAS from all responsibilities and liabilities for indirect or consequential damages resulting from the use or application of ECODAS SYSTEM.

1.1.3 TREATMENT EFFICIENCY

The treatment executed by the ECODAS SYSTEM is based on the sterilization principles using direct steam.

The thermo cycle is foreseen in order to reach a coefficient of a minimum sterilizing value of 500, equivalent to a bacteriological destruction equal or higher than 10^8 .

This sterilizing value lead to the destruction of all the bacterial spores, virus and bacteriophage, mold spores, microorganisms, and maintains the inactivation of virus etc.

1.1.4 BRIEF DESCRIPTION OF THE MACHINE

1.1.4.1 UPPER CHAMBER

The upper chamber includes an automatic loading cover for loading.

1.1.4.2 SHREDDER

The shredder is provided with two rotating shafts with knives revolving in opposite directions at regular intervals and at different speeds. It reduces the waste to small particles following the needs of the customer.

1.1.4.3 LOWER CHAMBER

The lower chamber is comprised of:

- A circular jacket with a cover allowing the unloading process to the hopper.
- Inner perforated jacket which enables the treatment of all the waste by steam.
- Two traps at the bottom of the lower chamber open automatically to unload the sterilized waste by gravity.

1.1.4.4 COLLECTION OF THE STERILIZED WASTE

The waste is collected in a moving dumper or a waste bin.

1.1.4.5 CONTROL PANEL

The panel consists of the necessary interface elements to control all the valves, motors, and air cylinders.

A processor generates a treatment report for each cycle; it calculates the FO value realized by the appliance. This calculation is generated based on the inputs of the probe located in the center of the lower chamber. The control of the pressure, temperature and treatment time are set to be very specific.

Important: In case of a failure or incident during a treatment cycle that requires repairing the machine, a special sterilizing program: Safety cycle, needs to be launched, to ensure basic safety precautions.

1.1.5 TECHNICAL DESCRIPTION

1.1.5.1 SYNOPTICS

10. Insulated treatment vessel

- 100 Vessel
- 102 Opening cover for loading
- 103 Shredder feeding cone
- 104 Opening cover for unloading
- 106 Vessel temperature probe
- N107 Low level of draining
- 108 Pressure probe inside the vessel
- 110 Pressure probe vessel bottom
- V181 Decompression « end of the cycle »
- V1010 Pressure safety valve
- V1011-1 Steam inlet through steam network
- V1011-2 Steam inlet inside the lower chamber of the thermal treatment
- V1014 Draining
- V1018 Vent
- V1021 Air cylinder for the opening and the closing of the loading cover
- 1022 Enlightened window for shredding visualization
- 1023 Loading gasket
- 1024 Articulation and support of loading cover
- V1025 Locking air cylinder of the loading cover
- V1026 Air cylinder for the opening and the closing of the loading cover
- V1042 Locking air cylinder of the unloading cover
- V1043 Air cylinder for the opening and the closing of the unloading belt
- 1044 Articulation and support of unloading cover
- V1045 Air cylinder for the opening and the closing of the unloading cover
- 1046 Unloading gasket

20. Shredder

- 201 Cutting unit set
- M202 Transmission and external motoreducer
- M203 Transmission and external motoreducer
- M210 Automatic lubricator

30. Lower chamber

- 301 Basket in the lower chamber
- 302 Unloading traps
- V303 Air cylinder of the traps opening
- 304 Temperature probe at the core of the waste

50. Control panel

- 5011 Control panel

60. Paddle

- M601 Motoreducer
- 602 Paddle body

70. Flash tank

700 Vessel
V1013 Solenoid valve for water inlet
FC90 Thermostat

ECODAS T150

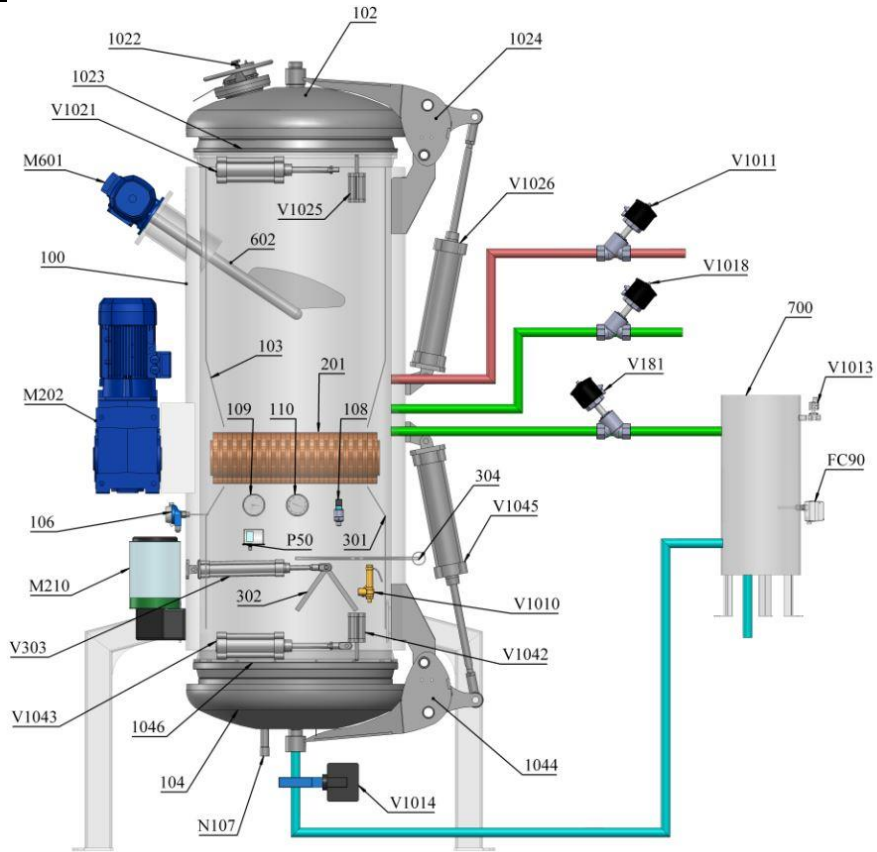

ECODAS T300

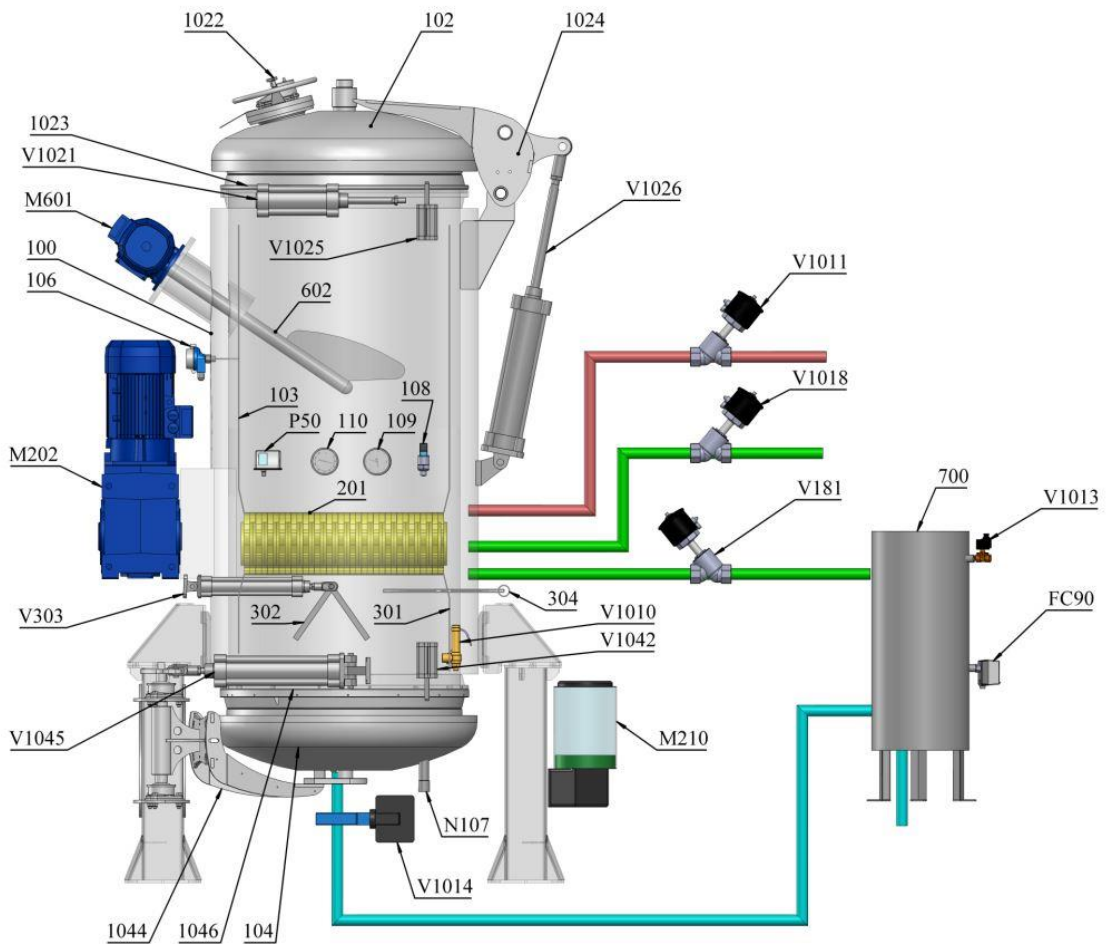

ECODAS T700 / T1000

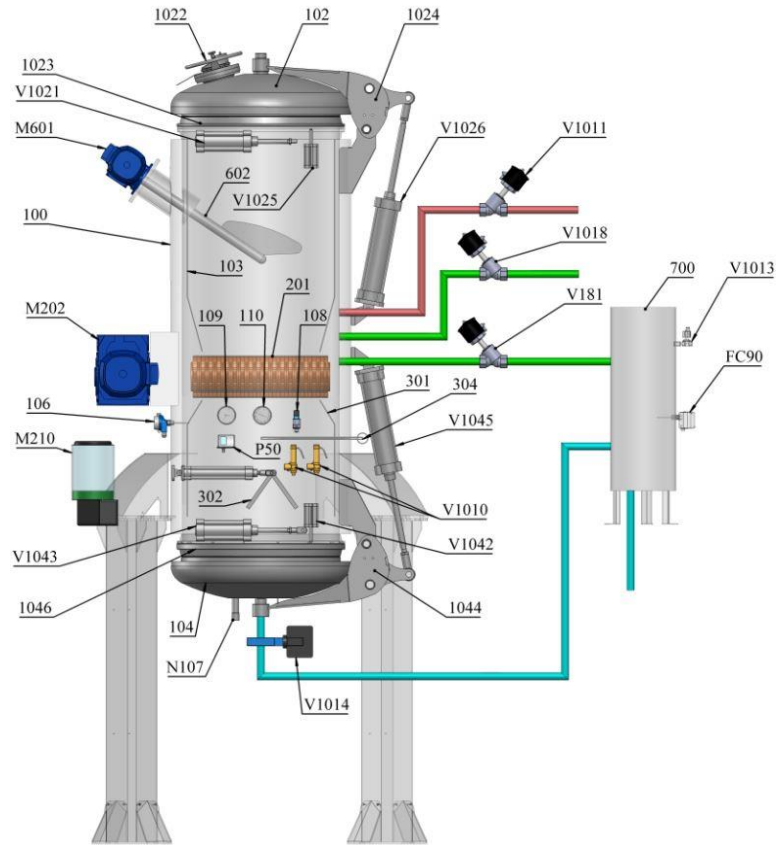

ECODAS T2000

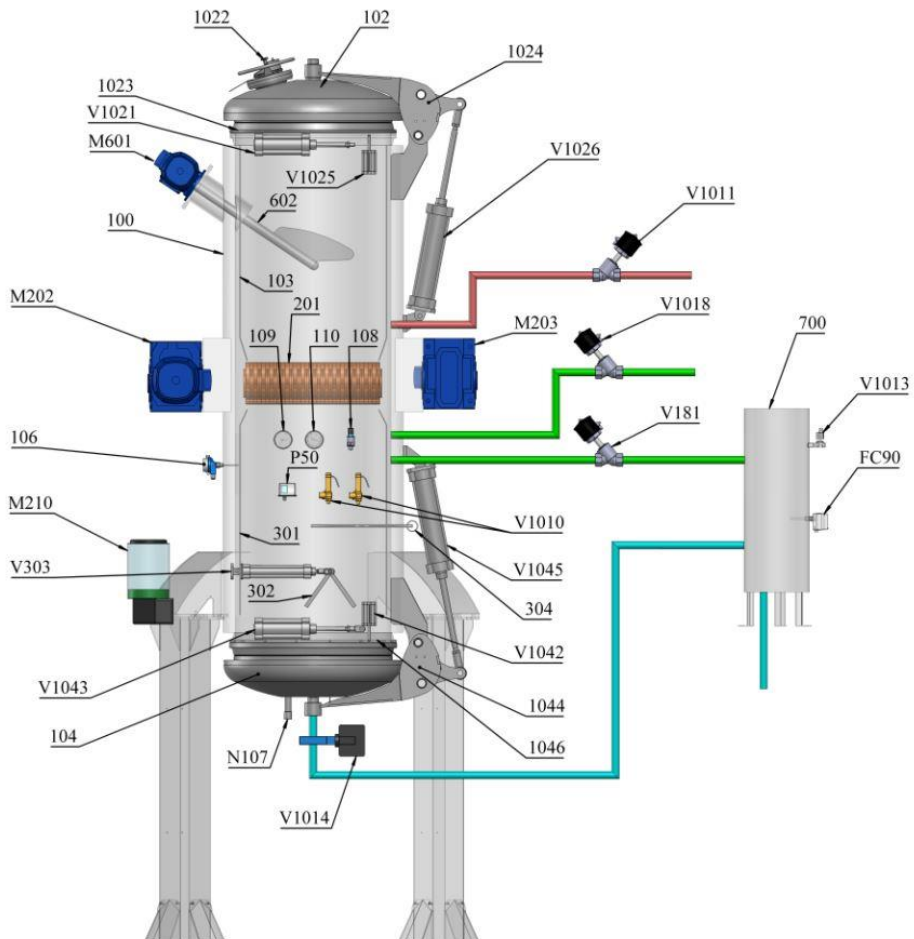

1.1.5.2 DESCRIPTION OF MECHANICAL COMPONENTS

TREATMENT VESSEL

100 Complete vessel made of stainless steel, insulated with 50 mm of rock wool, protected by stainless steel jacket and designed for:
 - operating pressure 4.5 bar
 - withstand at a maximum temperature of 150 ° C

102 Loading cover set including:

V1021 Air cylinder for the opening and the closing of the loading cover.

1022 Enlightened window for shredding visualization.

1023 Inflatable gasket to seal the loading cover.

Sealing of the cover by inflatable seal ensuring the pressure at 4.5 bar.

1024 Loading cover joint and rotation assembly with respect to the vessel.

V1025 Locking air cylinder of the loading cover.

V1026 Air cylinder for the opening and the closing of the loading cover.

103 Shredding feeding cone allowing a good presentation of the waste above the shredder.

104 Unloading cover set including:

V1042 Locking air cylinder of the unloading cover.

V1043 Air cylinder for the opening and the closing of the unloading cover.

V1044 Unloading cover joint and rotation assembly with respect to the vessel.

V1045 Air cylinder for the opening and the closing of the unloading cover.

1046 Inflatable gasket to seal the loading cover.

Sealing of the cover by inflatable seal ensuring the pressure at 4.5 bar

106 Vessel temperature probe

N107 Low level of draining

108 Pressure probe inside the vessel

109-1/109-2 Vessel temperature thermometer /Vessel manometer

110 Buttom vessel temperature probe

P50 Safety pressure switch

V181 - V1011/1- V1011/2 - V1014 - V1018 Valves for :

Decompression, Steam, Draining, Vent. Set of valves for regulating pressure and temperature. All valves are equipped with a stainless steel flapper with Teflon seal on stainless steel body seat. Opening by pneumatic distributor. Closing by spring at rest and lack of air or electricity.

V1010 Pressure safety valve with spring, Soupape de sûreté à ressort, stamped at 4.5 bars ensuring the pressure safety of the autoclave vessel.

SHREDDER

The shredding system is ensured by 2 rotating shafts on which are mounted cutting knives.

These knives are designed for the shredding and grinding of all the waste presented such as textiles, bandages, dialysis filters, syringes, quills, sharpeners, bottles, aluminum trays, bottles, packaging boxes.

Note that during the tests, we introduced stainless steel cutlery, small dentures and various metal accessories that did not affect the operation of the shredder.

The transmission is ensured between rollers by 2 internal gears to the vessel and by one or several shafts (depending on the model of machines) directly on the motoreducers outside of vessel.

The assembly is designed for 2 directions of rotation in order to ensure the automatic disruption of the shredder in case of overload or blockage.

Note that the particle size depends on the type of waste and their humidity. Therefore, the obtained results are average figures.

- 201** Cutting unit set
- M202** Transmission and external motoreducer
- M203** Transmission and external motoreducer (for ECODAS T2000 only)
- M210** Automatic lubricator

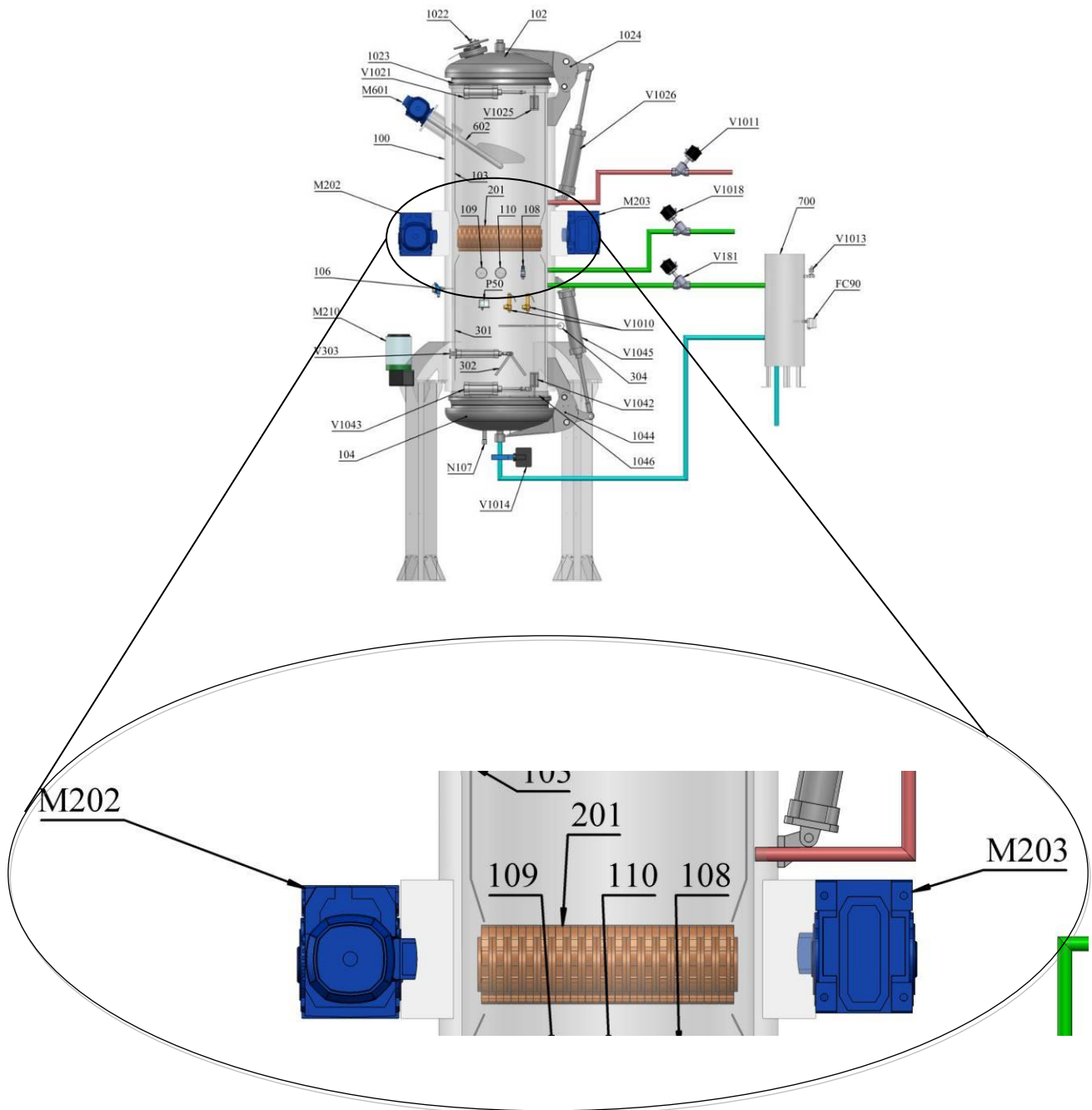

LOWER CHAMBER

- 301** Conical perforated outer casing for steam treatment at the core of the waste.
- 302** Traps made of 2 ½ circles articulated by a hinge externally operated.
- V303** Air cylinder for the traps closing and opening.
- 304** Probe located in the lower chamber in order to restore the temperature at the core of the waste.

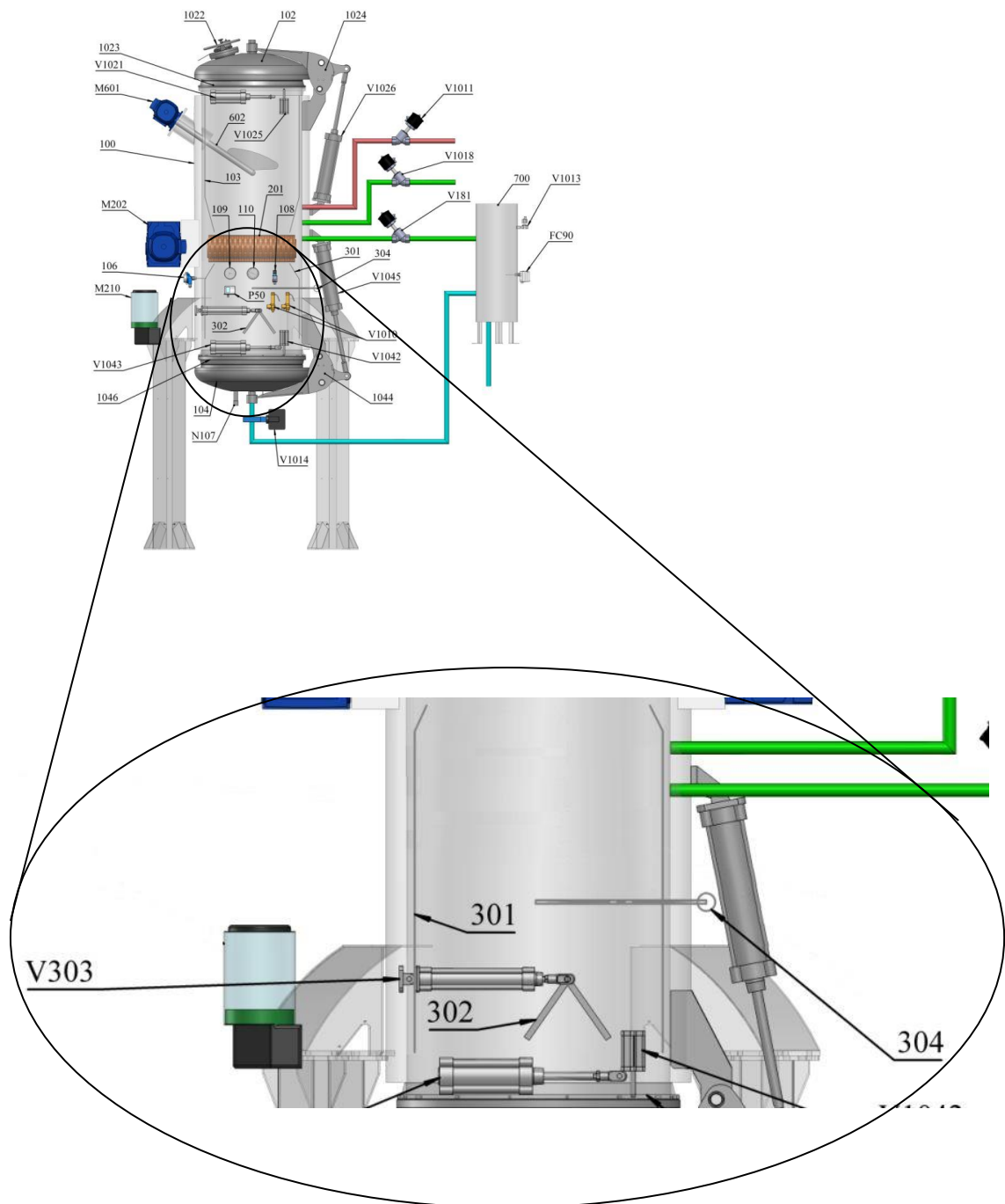

PADDLE

This set allows regular feeding of the shredder, regardless of the form and packaging of waste (plastic bags or containers of 20 to 50 liters, weighing from 1 to 15 kg).

M601 Motoreducer fixed on the vessel of the machine.

602 Paddle body with the palm for agitation with alternating movements, positioning the waste properly on the shredder knives.

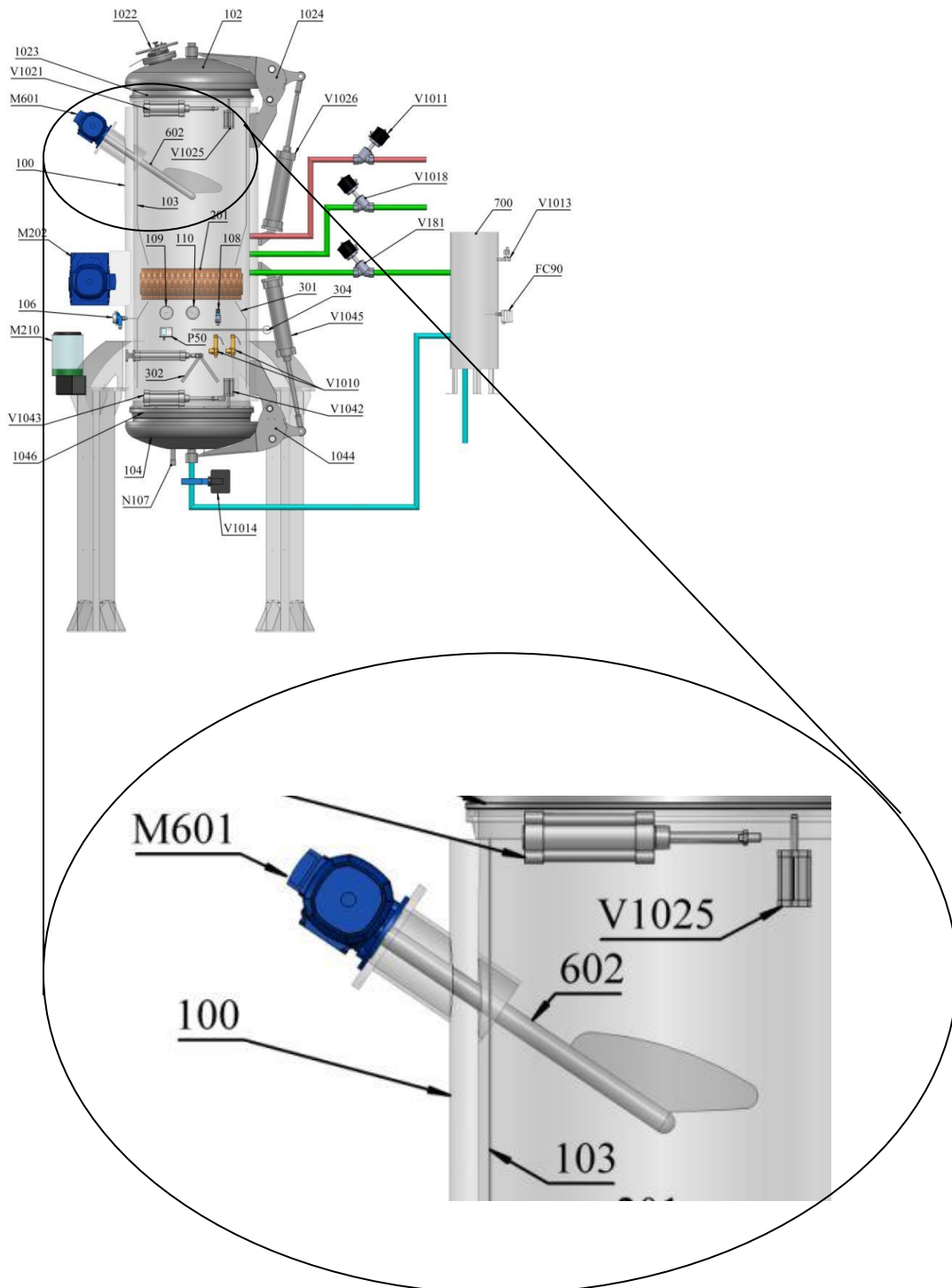

FLASH TANK

This device allows you to decompress and empty the machine at the end of the cycle.

The flash tank consists of a stainless steel tank containing water, allowing to relax the steam contained in the machine. The solenoid valve and the temperature probe allow to control the temperature of the water of discharges and to add cold water if necessary.

700 Stainless steel vessel.

V1013 Solenoid valve for water inlet.

113 Temperature probe allowing you to control the water temperature in the flash tank.

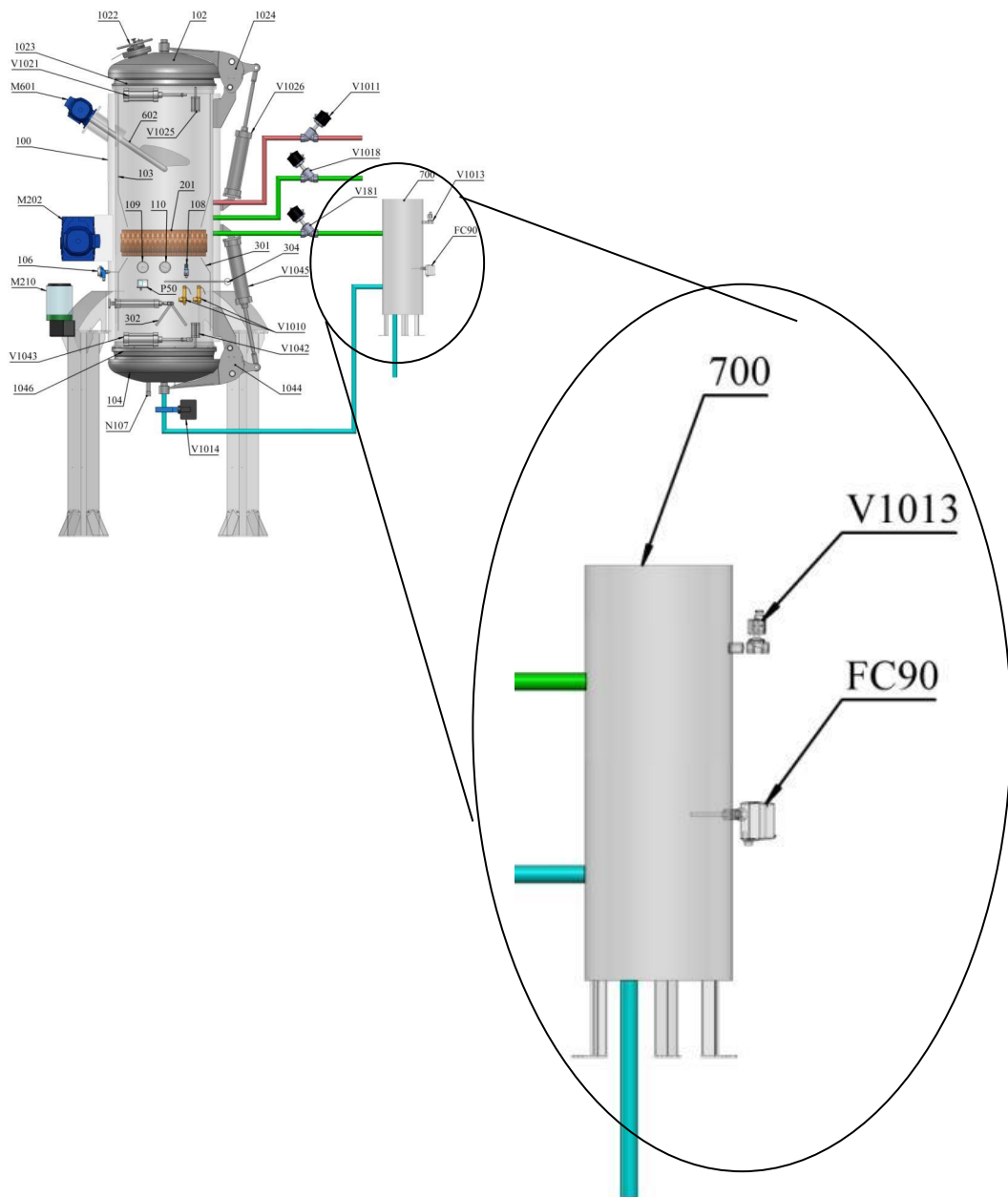

1.1.5.3 TECHNICAL SPECIFICATIONS

ECODAS T150

General Characteristics	
- Dimensions (L x l x H), cm	274x200x300
- Dimensions (L x W x H).ft	9x6.6x9.8
- Shipping Weight, Kg	800
- Max weight when filled with water For a special hydraulic test, Kg	1100
- Stress kg/cm ²	1
- Steam Pressure, Bar	8
- Max Steam Flow, Kg/h	6.5
- Compressed Air, Bars	6
- Electricity 380 V / 3-Phase	8 kW
Operating Characteristics	
- Average Cycle Time, Minutes	30
- Process Volume Capacity, Liters	150
- Average Waste Density, Kg/m ³	100-150
- Average Process Weight Capacity-kg/cycle	15-23
- Average Process Weight Capacity-lb/cycle	33-51
- Microbial Inactivation	8 log ₁₀
- Waste Volume Reduction	80%
Consumption / cycle	
- Steam, Kg	9
- Electricity, Kwh	1,4
- Water, Liters	15

Simulations	A 40 hours / week	C 80 hours / week	E 120 hours / week
Major characteristics			
Waste density (Kg/l) :	0,10	0,10	0,10
Average Weight/cycle (Kg)	15,00	15,00	15,00
Average Time/cycle (in mn) :	30,00	30,00	30,00
Average weight / hour (kg)	30,00	30,00	30,00
Electricity/cycle (Kw) :	1,40	1,40	1,40
Water/cycle m ³ :	0,015	0,015	0,015
Steam/cycle (Kg) :	9,00	9,00	9,00
Maintenance (Basis 4000 Cycles)	4 622,00	4 622,00	4 622,00
Working parameters			
Nber hours/week :	40,00	80,00	120,00
Electricity cost in €/Kw	0,09	0,09	0,09
Water cost in €/m ³	2,50	2,50	2,50
Steam cost in €/Kg	0,02	0,02	0,02
Nber of hours / year :	2 080,00	4 160,00	6 240,00
Nber of cycles / day :	16,00	32,00	48,00
Nber of cycles / year :	4 160,00	8 320,00	12 480,00
Capacity in Tons / year :	62,40	124,80	187,20

ECODAS T300

General Characteristics	
- Dimensions (L x l x H), cm	270x210x330
- Dimensions (L x W x H).ft	9.8x6.8x10.83
- Total volume, L	1111
- Shipping Weight, Kg	2000
- Max weight when filled with water For a special hydraulic test, Kg	3111
- Stress kg/cm ²	2
- Steam Pressure, Bar	8
- Max Steam Flow, Kg/h	170
- Compressed Air, Bars	6
- Electricity 380 V / 3-Phase	14 kW
Operating Characteristics	
- Treatment temperature, °C	130 - 177
- Average Cycle Time, Minutes	30
- Max Loading Volume Capacity, Liters	507
- Average Process Volume Capacity, Liters	350
- Average Waste Density, Kg/m ³	100-150
- Average Process Weight Capacity-kg/cycle	35-53
- Average Process Weight Capacity-lb/cycle	77-117
- Microbial Inactivation	10 ⁸
- Waste Volume Reduction	80%
- Max Waste weight Reduction (depending on the nature of the waste)	40%
Consumption / cycle	
- Steam, Kg	15
- Electricity, Kwh	1,7
- Water, Liters	25

Simulations	A 40 hours / week	C 80 hours / week	E 120 hours / week
Major characteristics			
Waste density (Kg/l) :	0,10	0,10	0,10
Average Weight/cycle (Kg)	35,00	35,00	35,00
Average Time/cycle (in mn) :	30,00	30,00	30,00
Average weight / hour (kg)	70,00	70,00	70,00
Electricity/cycle (Kw) :	1,70	1,70	1,70
Water/cycle m ³ :	0,025	0,025	0,025
Steam/cycle (Kg) :	15,00	15,00	15,00
Maintenance (Basis 8000 Cycles)	7 622,00	7 622,00	7 622,00
Working parameters			
Nber hours/week :	40,00	80,00	120,00
Electricity cost in €/Kw	0,09	0,09	0,09
Water cost in €/m ³	2,50	2,50	2,50
Steam cost in €/Kg	0,02	0,02	0,02
Nber of hours / year :	2 080,00	4 160,00	6 240,00
Nber of cycles / day :	16,00	32,00	48,00
Nber of cycles / year :	4 160,00	8 320,00	12 480,00
Capacity in Tons / year :	145,60	291,20	436,80

ECODAS T700

General Characteristics	
- Dimensions (L x l x H), cm	460x430x520
- Dimensions (L x W x H).ft	15,1x14,1x17,1
- Total volume. L	1715
- Shipping Weight. Kg	2500
- Max weight when filled with water For a special hydraulic test. Kg	4215
- Stress kg/cm ²	2,0
- Steam Pressure. Bar	8
- Max Steam Flow. Kg/h	230
- Compressed Air. Bars	6
- Electricity 380 V / 3-Phase	20 kW
Operating Characteristics	
- Treatment temperature. °C	130 - 177
- Average Cycle Time. Minutes	30
- Max Loading Volume Capacity. Liters	787
- Average Process Volume Capacity. Liters	700
- Average Waste Density. Kg/m ³	100-150
- Average Process Weight Capacity-kg/cycle	70-105
- Average Process Weight Capacity-lb/cycle	155-231
- Microbial Inactivation	10 ⁶
- Waste Volume Reduction	80%
- Max Waste weight Reduction (depending on the nature of the waste)	40%
Consumption / cycle	
- Steam. Kg	18
- Electricity. Kwh	3,5
- Water. Liters	30

Simulations	A 40 hours / week	C 80 hours / week	E 120 hours / week
Major characteristics			
Waste density (Kg/l) :	0,10	0,10	0,10
Average Weight/cycle (Kg)	70,00	70,00	70,00
Average Time/cycle (in mn) :	35,00	35,00	35,00
Average weight / hour (kg)	120,00	120,00	120,00
Electricity/cycle (Kw) :	4,00	4,00	4,00
Water/cycle m ³ :	0,035	0,035	0,035
Steam/cycle (Kg) :	20,00	20,00	20,00
Maintenance (Basis 6000 cycles)	11 500,00	11 500,00	11 500,00
Working parameters			
Nber hours/day :	40,00	80,00	120,00
Electricity cost in €/Kw	0,09	0,09	0,09
Water cost in €/m ³	2,50	2,50	2,50
Steam cost in €/Kg	0,02	0,02	0,02
Nber of hours / year :	2 080,00	4 160,00	6 240,00
Nber of cycles / day :	13,71	27,43	41,14
Nber of cycles / year :	3 565,71	7 131,43	10 697,14
Capacity in Tons / year :	249,60	499,20	748,80

ECODAS T1000

General Characteristics	
- Dimensions (L x l x H), cm	490x460x640
- Dimensions (L x W x H).ft	16,1x15,1x21
- Total volume. L	2500
- Shipping Weight. Kg	2800
- Max weight when filled with water For a special hydraulic test. Kg	5300
- Stress kg/cm ²	2,5
- Steam Pressure. Bar	8
- Max Steam Flow. Kg/h	370
- Compressed Air. Bars	6
- Electricity 380 V / 3-Phase	20 kW
Operating Characteristics	
- Treatment temperature. °C	130 - 177
- Average Cycle Time. Minutes	35
- Max Loading Volume Capacity. Liters	1269
- Average Process Volume Capacity. Liters	1100
- Average Waste Density. Kg/m ³	100-150
- Average Process Weight Capacity-kg/cycle	110-165
- Average Process Weight Capacity-lb/cycle	243-364
- Microbial Inactivation	10 ⁶
- Waste Volume Reduction	80%
- Max Waste weight Reduction (depending on the nature of the waste)	40%
Consumption / cycle	
- Steam. Kg	20
- Electricity. Kwh	4
- Water. Liters	35

Simulations	A 40 hours / week	C 80 hours / week	E 120 hours / week
Major characteristics			
Waste density (Kg/l) :	0,10	0,10	0,10
Average Weight/cycle (Kg)	110,00	110,00	110,00
Average Time/cycle (in mn) :	35,00	35,00	35,00
Average weight / hour (kg)	189,00	189,00	189,00
Electricity/cycle (Kw) :	4,00	4,00	4,00
Water/cycle m ³ :	0,035	0,035	0,035
Steam/cycle (Kg) :	20,00	20,00	20,00
Maintenance (Basis 6000 cycles)	11 500,00	11 500,00	11 500,00
Working parameters			
Nber hours/day :	40,00	80,00	120,00
Electricity cost in €/Kw	0,09	0,09	0,09
Water cost in €/m ³	2,50	2,50	2,50
Steam cost in €/Kg	0,02	0,02	0,02
Nber of hours / year :	2 080,00	4 160,00	6 240,00
Nber of cycles / day :	13,71	27,43	41,14
Nber of cycles / year :	3 565,71	7 131,43	10 697,14
Capacity in Tons / year :	392,23	784,46	1 176,69

ECODAS T2000

General Characteristics	
- Dimensions (L x l x H), cm	490x460x640
- Dimensions (L x W x H).ft	16,1x15,1x21
- Total volume. L	5285
- Shipping Weight. Kg	5200
- Max weight when filled with water For a special hydraulic test. Kg	10485
- Stress kg/cm ²	3,5
- Steam Pressure. Bar	8
- Max Steam Flow. Kg/h	500
- Compressed Air. Bars	6
- Electricity 380 V / 3-Phase	35 kW
Operating Characteristics	
- Treatment temperature. °C	130 - 177
- Average Cycle Time. Minutes	45
- Max Loading Volume Capacity. Liters	2572
- Average Process Volume Capacity. Liters	2500
- Average Waste Density. Kg/m ³	100-150
- Average Process Weight Capacity-kg/cycle	250-375
- Average Process Weight Capacity-lb/cycle	551-827
- Microbial Inactivation	10 ⁶
- Waste Volume Reduction	80%
- Max Waste weight Reduction (depending on the nature of the waste)	40%
Consumption / cycle	
- Steam. Kg	40
- Electricity. Kwh	9
- Water. Liters	50

Simulations	A 40 hours / week	C 80 hours / week	E 120 hours / week
Major characteristics			
Waste density (Kg/l) :	0,10	0,10	0,10
Average Weight/cycle (Kg)	250,00	250,00	250,00
Average Time/cycle (in mn) :	45,00	45,00	45,00
Average weight / hour (kg):	330,00	330,00	330,00
Electricity/cycle (Kw) :	9,00	9,00	9,00
Water/cycle m ³ :	0,05	0,05	0,05
Steam/cycle (Kg) :	40,00	40,00	40,00
Maintenance (Basis 4000 cycles)	13 500,00	13 500,00	13 500,00
Working parameters			
Nber hours/week :	40,00	80,00	120,00
Electricity cost in €/Kw	0,09	0,09	0,09
Water cost in €/m ³	2,50	2,50	2,50
Steam cost in €/Kg	0,02	0,02	0,02
Nber of hours / year :	2 080,00	4 160,00	6 240,00
Nber of cycles / day :	10,67	21,33	32,00
Nber of cycles / year :	2 773,33	5 546,67	8 320,00
Capacity in Tons / year :	693,33	1 386,67	2 080,00

1.1.5.4 DIMENSIONS, FOOTPRINT

ECODAS T150

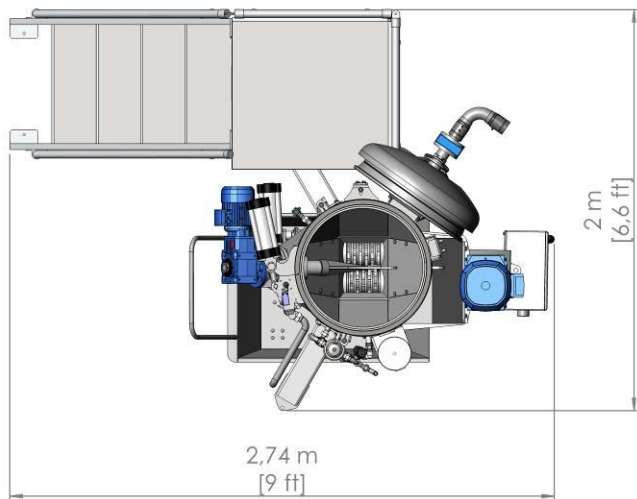
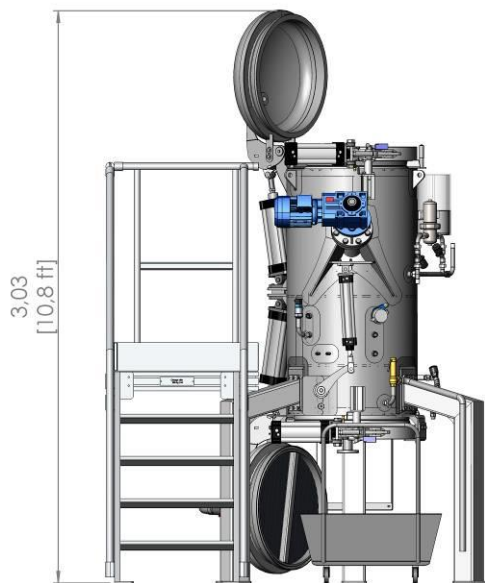
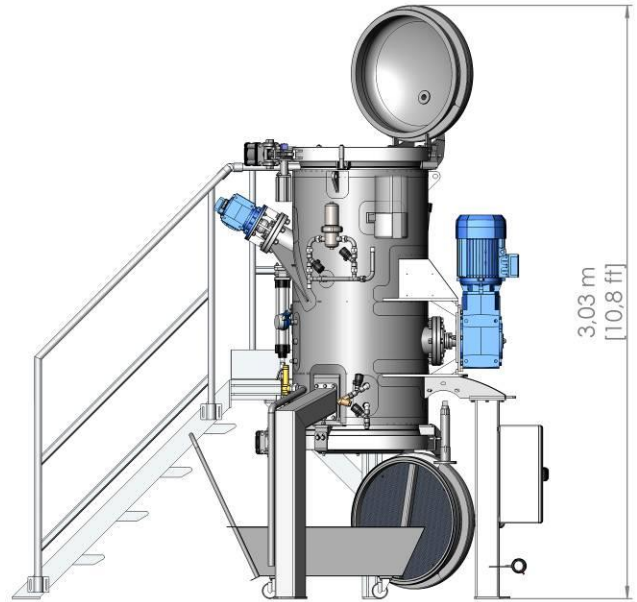

ECODAS T300

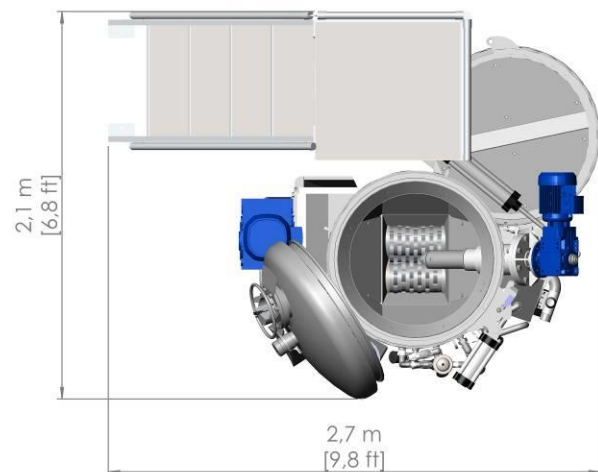
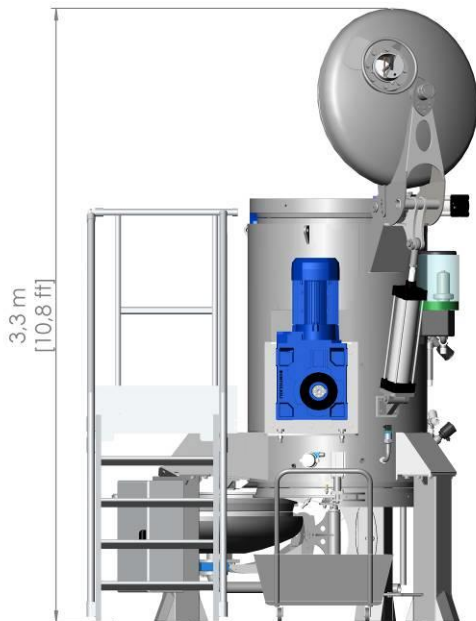
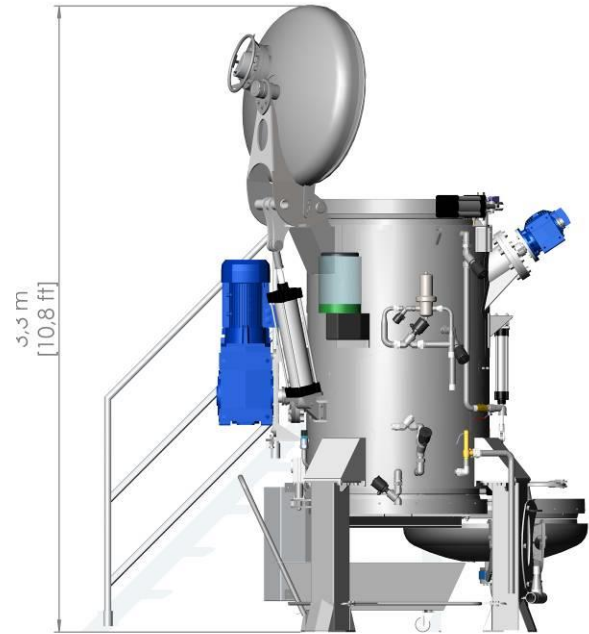
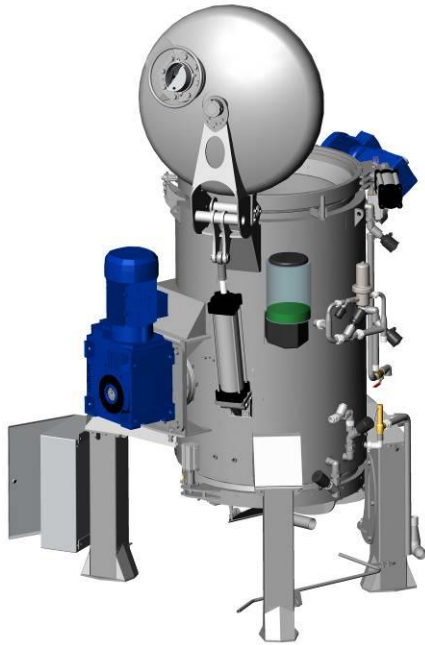

ECODAS T700 / T1000

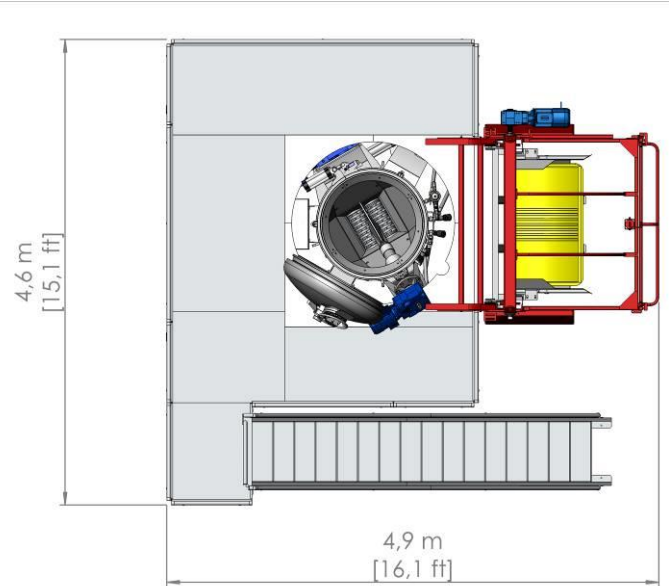
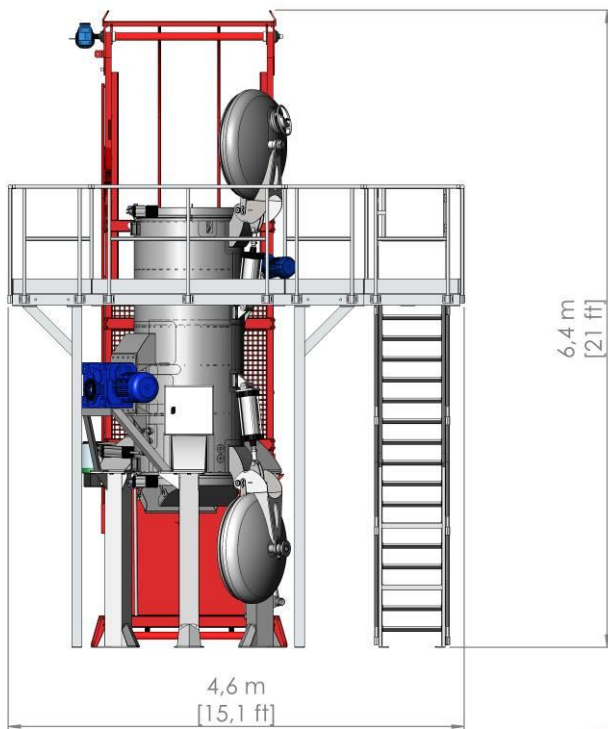
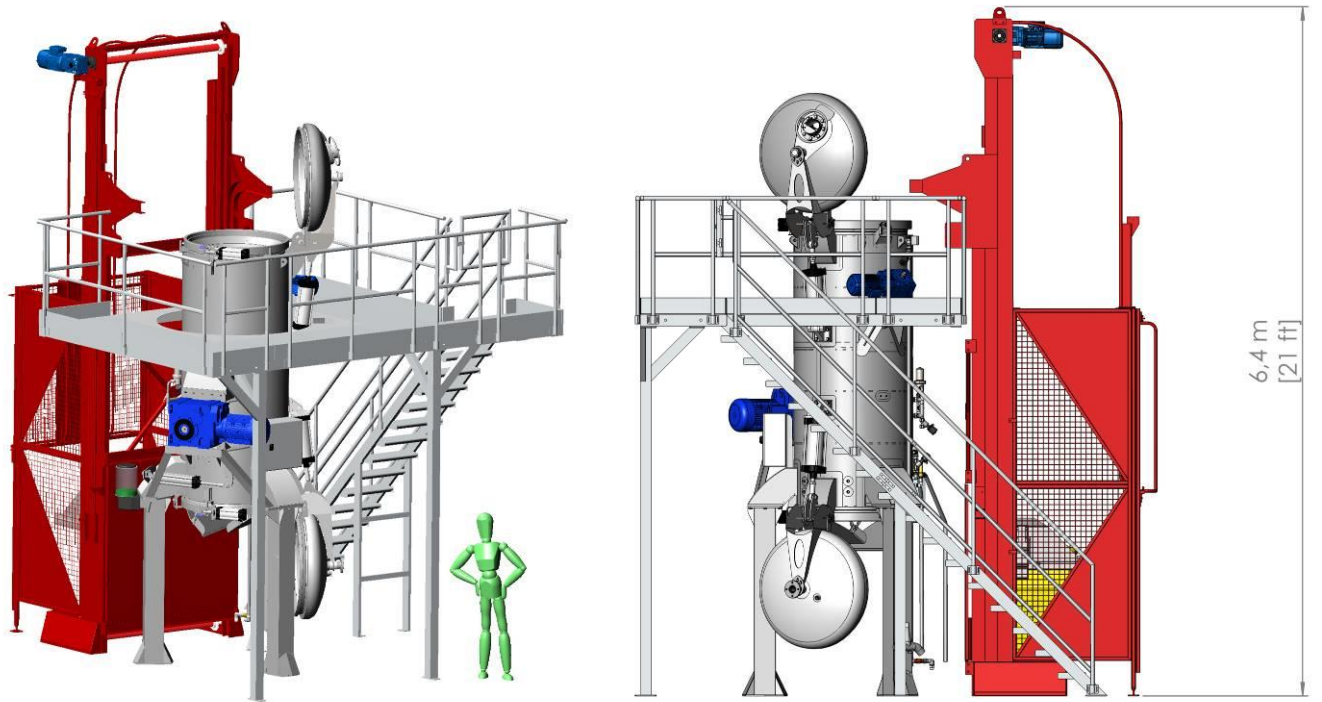

ECODAS T2000

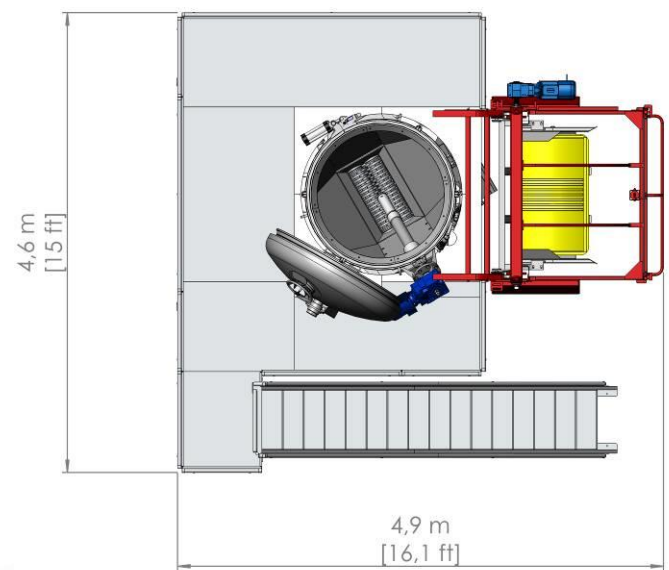
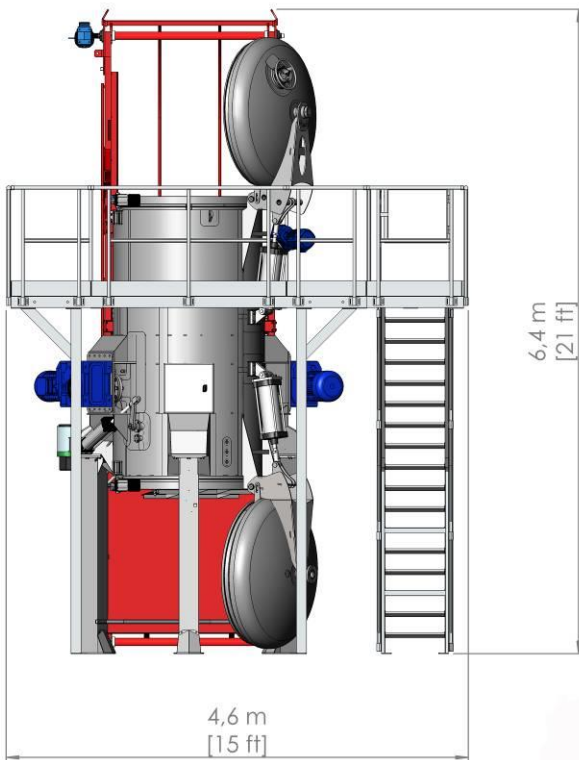
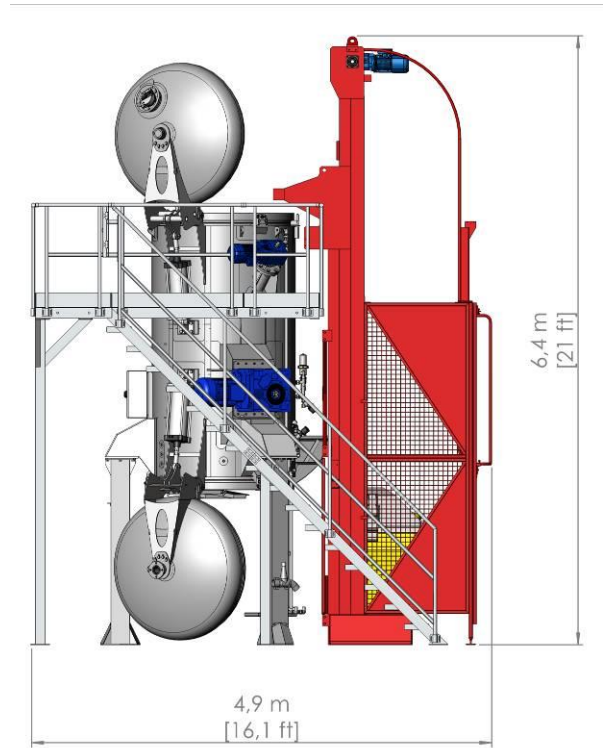
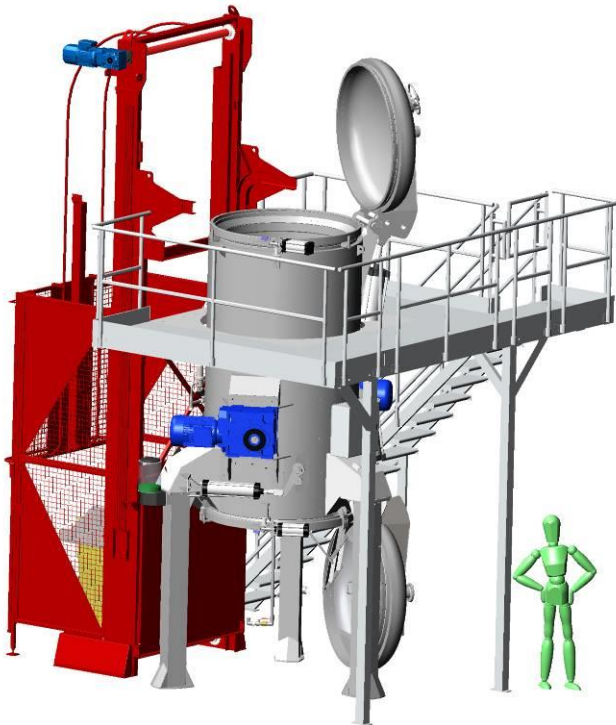

1.1.6 CERTIFICATIONS

Certificate

Quality Assurance System
acc. to Directive 2014/68/EU

Certificate no.: 01 202 F/Q-05 20176.00

Name and address of the certificate holder: ECODAS
28, rue Sébastopol
59100 ROUBAIX
France

Herewith we certify that the above -mentioned manufacturer operates a quality system according to the European Directive 2014/68/EU. The manufacturer has the permission to affix the following CE marking to pressure equipment described and manufactured in accordance to the scope covered by this Quality-Assurance System:

CE 0035

Test basis: Directive 2014/68/EU: QA-System (Module H1)

Audit report no.: 01 202 F/Q-05 20176

Scope: Sterilization machines for infectious waste of type ECODAS T100-T150-T300-T700-T1000-T2000 Boilers VE40kW-VE80kW, see annex to certificate: 01 202 F/Q-05 20176, revision 4 from 12/04/2023

Manufacturing plant: see certificate holder

Validity: This certificate is valid until 2026-05-31.

Cologne, 2023-07-11
Dipl.-Ing. (FH) Vera Ruff



TÜV Rheinland Industrie Service GmbH
Notified Body for Pressure Equipment, ID-No. 0035
Am Gittern 160a, D-51105 Cologne

MS-0037317 E-006-Rev01

www.tuv.com



TÜVRheinland®
Precisely Right.

Certificate

Standard **ISO 9001:2015**
 Certificate Registr. No. **MS19 Q 11109**
 ID No: **9105016092**

Certificate Holder:



ECODAS
 28 rue Sebastopol
 59100 ROUBAIX
 France.

Scope : Design, manufacturing, installation, training, and maintenance of infectious waste treatment equipment (healthcare, life science, slaughterhouses, airport...).
 Shredding and sterilization process using saturated steam, sterilization of liquid waste, steam generators.

Proof has been furnished by means of an audit that the requirements of ISO 9001:2015 are met.

Certification decision on: 05.07.2021
 Valid from 07.07.2021 to 06.07.2024
 Expiry of previous certificate: 06.07.2021

Edited on 05.07.2021

TÜV Rheinland France
 20ter rue de Bezons
 92400 COURBEVOIE

www.tuv.com



10201 10.17.D.A4 © TÜV, TÜEV und TÜV sind eingetragene Marken. Eine Nutzung und Verwendung bedarf der vorherigen Zustimmung.

Certificate

Standard **ISO 14001:2015**
 Certificate Registr. No. **MS18 E 11072**
 ID No: **9105016092**

Certificate Holder:



ECODAS
 28 rue Sebastopol
 59100 ROUBAIX
 France.

Scope : Design, manufacturing, installation, training, and maintenance of infectious waste treatment equipment (healthcare, life science, slaughterhouses, airport...).
 Shredding and sterilization process using saturated steam, sterilization of liquid waste, steam generators.

Proof has been furnished by means of an audit that the requirements of ISO 14001:2015 are met.

Certification decision on: 05.07.2021
 Valid from 08.08.2021 to 07.08.2024
 Expiry of previous certificate: 07.08.2021

Edited on 05.07.2021

TÜV Rheinland France
 20ter rue de Bazons
 92400 COURBEVOIE

16091 10.12.044 © TÜV, TÜV und TÜV sind eingetragene Marken. Eine Haftung und Verantwortung bedarf der vorherigen Zustimmung.

www.tuv.com



The American Society of Mechanical Engineers

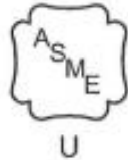

CERTIFICATE OF AUTHORIZATION

The named company is authorized by The American Society of Mechanical Engineers (ASME) for the scope of activity shown below in accordance with the applicable rules of the ASME Boiler and Pressure Vessel Code. The use of the ASME Single Certification Mark and the authority granted by this Certificate of Authorization are subject to the provisions of the agreement set forth in the application. Any construction stamped with the ASME Single Certification Mark shall have been built strictly in accordance with the provisions of the ASME Boiler and Pressure Vessel Code.

COMPANY:

Ecodas
28 Rue Sebastopol
Roubaix 59100
France

SCOPE:

Manufacture of pressure vessels at the above location only

AUTHORIZED: December 17, 2023
EXPIRES: December 17, 2026
CERTIFICATE NUMBER: 59077

[Signature]
Board Chair, Conformity Assessment

[Signature]
Managing Director, Standards & Engineering Services



1.1.7 SOUND LEVEL



VI - CONCLUSION

Les mesures réalisées à proximité de l'autoclave stérilisateur TDS 2000 du Centre Hospitalier de Valenciennes indiquent :

LAeq = 73,4 dBA au poste de commande

LAeq = 71,5 dBA au poste de chargement

A votre disposition pour toute assistance technique complémentaire, nous vous prions d'agréer, Monsieur, l'expression de nos salutations distinguées.

Le Chef du Département Mesures
en Environnement

A handwritten signature in black ink, appearing to be 'M. Borkowski', is written over a light blue circular stamp. The signature is fluid and cursive.

M. BORKOWSKI

Dossier suivi par Reynald FONTAINE Chargé d'affaires acoustique : Tél . 20.42.76.28

1.1.8 LIFT TEST CERTIFICATE



VOTRE PARTENAIRE SANTÉ & ENVIRONNEMENT

TESTS CERTIFICATE

Lift for wheeled skips: 660 / 770 liters

Brand: EODA

Type: 2013/876/001 Lift assembly H-6330

Motor: UH40 2.2 KW

Dimensions of wheeled skips according to EN 840.

Lifting capacity : Maximum Working Load 150 kg

TYPE	OPERATION
Static test 125 %	Tests carried out in our workshops with 8 barrels of 25 kg of grease for a total of 200 kg
	Holding time : 60 minutes
	3 different heights : low, medium, high
Dynamic test 110 %	Tests carried out in our workshops with 7 barrels of 25 kg of grease for a total of 175 kg
	Test carried out at steady state, at high speed up and down
	Maximum current absorbed when ascending: 5.1 A
	Maximum current absorbed during descent: 3.9 A

Made in Roubaix – France, on April 15th 2022

1.2 SAFETY INSTRUCTIONS - ACCIDENT PREVENTION



All the following indications must be absolutely respected:

- The operation of ECODAS SYSTEM must be carried out by authorized staff trained and taught about all the risks relating to such a material.
- The installation can only be maintained or repaired by a trained staff member or by the manufacturer's service technicians.
- Any modifications to the machine or to its installation without the manufacturer's written agreement are prohibited and release ECODAS SAS from all responsibility in the matter.

*** PRIOR TO ANY MAINTENANCE OR SERVICE WORK INTERVENTION:**

- Make sure that the previous cycle was executed properly, otherwise launch a Sterilization Cycle. If this instruction is not respected, the maintenance or repairing staff are at contamination risk.
- Make sure to stop the machine by turning OFF the main power disconnect switch on the electrical panel and locking out the power source.
- Do not by pass the safety system and carry out any service work. Safety sensor has to be kept ON to properly run the machine and to protect the personnel in the vicinity of the machine as well from any danger.
- In case of a shredder jam, launch the Safety Cycle before removing jammed elements from the shredder.
- The customer is responsible to service the machine once a year by an approved/registered office (pressurized appliance).
- Do not modify the cycle parameters in the programs.
- A notebook concerning the maintenance and service schedule will be provided by the registered office. It will have to indicate the type, dates, and the results of all service or repair made to the machine. Simultaneously, the cycle report, printed by the PLC after servicing the machine has to be archived.

- Following the basic rules of care and their order that has been stated ensure maximum safety.
- Avoid direct, repeated or prolonged contact with the waste. If necessary, safety equipment (steel toes boots, gloves, safety goggles) adapted to the risks must be used.
- The operator must inspect the machine before every shift. Any fault would bring the machine to an immediate stop for maintenance.
- The qualified staff must execute the periodic maintenance. Each appliance must be regularly checked.
- It is strictly forbidden to smoke or eat near the machine.
- The operator must follow and properly apply the safety instructions. Remind them as often as possible by any appropriated means.
- Power can be applied back to the machine only if the defected part is repaired, materials and tools being picked up and the service technicians have cleared the work area.
- Any transformation or change, even temporary is not allowed.
- Damage to the electrical components can occur if original fuses/protections are replaced by higher intensity counterparts.
- E-stop does not disconnect the electrical supply to the machine. When it is pressed the power is removed from the motors and pneumatic solenoid valves instantly and the machine comes to an immediate stop.
- After using the machine, its area must be cleaned up with a disinfecting product.
- Damaging or by passing any safety element of the system is strictly forbidden.

1.2.1 TREATMENT VESSEL

The Vessel does not require any particular treatment necessary. It is entirely made of stainless steel, has been treated by rust preventatives then insulated.

The different safety setups (electrical, pressures, levels) must be tested and checked by an approved organism within an eighteen-month period (maximum time) then recorded in a maintenance notebook.

1.2.2 SHREDDER

A skilled person must check the electrical safety measures of the shredder:

- Before running the machine the first time.
- On a regular basis.
- After a repair or maintenance job.



ATTENTION: During these occasions, or while removing jammed item in the shredder, the main disconnect switch must be turned OFF, and the loading cover must be opened in order to eliminate any risk of pressurizing the machine.

IGNORING SAFETY INSTRUCTIONS

Ignoring safety instructions could result in serious personal injuries, damage to the machine and/or most of all putting the environment in danger by releasing non sterilized waste in it.

ATTENTION: ECODAS SAS will take no responsibility for any accidents, injuries to personnel or damage to the machine or to the environment if the equipment is installed, operated or serviced without following the instructions in this manual.

1.3 DESCRIPTION DU CYCLE DE FONCTIONNEMENT

The waste load is emptied manually (T150/T300) or automatically through the lift (T150/T300/T700 /T1000/T2000) into the upper chamber. This loading chamber has been entirely disinfected in the previous cycle then cooled down to provide the operator with good and safe work conditions.

During the loading process, the Shredder is OFF.

After loading the contaminated waste the operator closes the upper lid of the sealed chamber and starts the automatic cycle. The whole cycle is controlled by a PLC (programmable logic controller) and the waste can only be released if the disinfection cycle is totally completed.

Treatment cycle



The cycle directions

Pushing “Start Cycle” on the touch screen allows loading the contaminated waste.

After the completion of the loading process, the program advances to the shredding process.

Turn ON the shredder: The waste is directly feed to the blades from the upper chamber by gravity. The paddle has a spiral and an alternate motion to toss, mix and place bags properly on the shredder knives.

The average time of the shredding process is 10-20 minutes depending on the type of machine, and it depends on the type and volume of the waste treated. The completion of this step is detected by the control system based on the absorbed intensity of the motor (Constant intensity and non changeable by the user).

For security reasons, the rotation of the blades is maintained for few minutes in order to discharge the maximum residual shredded items remaining in the knives. These remaining items are disinfected at the same time as the rest and it does not matter if some little quantity hangs in the shredder. Eventually they will be evacuated with the following load.

The temperature is raised until it reaches a uniform temperature of 138°C in the centre of the waste; and then maintained at that level for ten minutes.

ATTENTION: Maintaining a Constant temperature at 138°C and for 10 minutes are the two key parameters that enable to sterilize the waste.

It is necessary to point out that as the temperature increases the pressure raises until 4,1 bars maximum.

The combination between the temperature and the cycle time determines the sterilization coefficient that is compatible with the purpose of the treatment (F0=500).

The PLC controls the treatment process. It checks the accuracy of the sterilization coefficient by monitoring the temperature using a temperature sensor located inside the waste.

The cooling process of the outer part of the chamber of the machines stops at set temperature. The condensations are drained once this level is reached, and the vacuum is executed in order to eliminate the remaining steam.

Once this operation is over, an output signal informs the operator that he can unload the treated waste.

The whole cycle is guided by a PLC that monitors the process and generates historic trends at the end of the cycle; along with the calculation of the sterilizing value for every batch.

A screen enables to visualize at any time the appliance state and the cycle stage.

The final product is a sterilized and shredded waste which can be disposed as a household waste.

PLC Program # 1: STERILIZATION CYCLE:

- 0 – START CYCLE
- 1 – LOADING Stage
- 2 – SHREDDING Stage
- 3 – HEATING Stage
 - **Temperature: 138°C (Final heating temperature)**
- 4 – Standing Stage
 - **Temperature: 138°C (Constant temperature)**
 - **Time: 10 minutes (Minimum time to maintain required temperature)**
 - **F0: 500 (Sterilizing value)**
- 5 – COOLING Stage
 - **Final cooling temperature (ajustable)**
- 6 – DRAINING Stage
- 7 – UNLOADING Stage
- 8 – END CYCLE

This cycle is used for waste sterilization



PLC Program # 2: SAFETY CYCLE:

- 0 – STARTING CYCLE
- 3 – HEATING Stage
 - **Temperature: 138°C (Final heating temperature)**
- 4 – Standing Stage
 - **Temperature: 138°C (Constant temperature)**
 - **Time: 30 minutes (Minimum time to maintain required temperature)**
 - **F0: 1500 (Sterilizing value)**
- 5 – COOLING Stage
 - **Final cooling temperature (ajustable)**
- 6 – DRAINING Stage
- 7 – UNLOADING Stage
- 8 – END CYCLE

This cycle must be launched before any maintenance or repairing intervention..

PLC Program # 3: CLEANING CYCLE:

- 0 – STARTING CYCLE
- 8 – UNLOADING Stage
- 9 – END CYCLE Stage

This cycle must be launched to clean the traps and the lower chamber.

1.4 OPERATING THE MACHINE

1.4.1 OPERATOR MACHINE INTERFACE

1.4.1.1 INTRODUCTION

The HMI touch screen is user-friendly; it uses names and function parameters instead of codes. The information of the cycles, alarms, and other parameters are clearly displayed.

An auto-explanation is accessed with the function keys on the HMI touch screen.

The HMI touch screen allows the operator to directly interface with the machine's controls. It also displays all the functions, parameters, stages, temperature diagrams and the sterilization FO factor.

The operator's console configurations require a password to restrict access to only administrators in order to prevent improper modification of the programs by unauthorized users. Operators in the other hand can only execute the start up cycle.

The operator's console integrated security options:

1. Control of the battery life time and temperature of the console.
2. Report of all the alarm occurred during a cycle: type, and frequencies of all the alarms.
3. Display of main alarms on the screen with the option to view others if desired.
4. The PLC is connected to a printer to generate reports of all the events occurred during a treatment cycle..

1.4.1.2 SCREEN OVERVIEW

The screenshot shows the HMI touch screen interface. At the top left, the date and time are displayed as '3/29/2024 4:13 PM'. Below this is a table of machine parameters:

Waste temperature	°C
Vessel temperature	°C
Vessel pressure	0.0Bar

The main menu area is titled 'MAIN MENU' and includes a 'User : Ecodas' field and a 'LOGOUT' button. A large 'STOP' button is visible in the center. Below it is a 'START CYCLE' button. Callouts point to various elements: 'Date & hour' points to the top left; 'Temperature & pressure in the machine' points to the parameter table; 'Menu name' points to the 'MAIN MENU' header; 'User name/ Connection' points to the 'User : Ecodas' field; 'Machine state (stop or start)' points to the 'STOP' button; 'Messages appear to indicate a machine alarm' points to the 'START CYCLE' button; and 'Push button (here to start a new cycle)' points to the 'START CYCLE' button.

1.4.1.3 DEFAULT SCREEN AT START UP



The screen comes up during a POWER UP or if the machine is idle on "MAIN MENU" for 5 minutes.

1.4.1.4 LOGIN WITH A USERNAME AND A PASSWORD

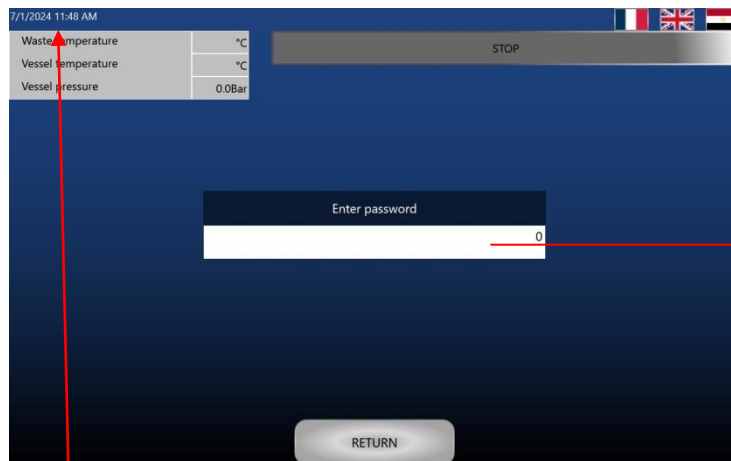
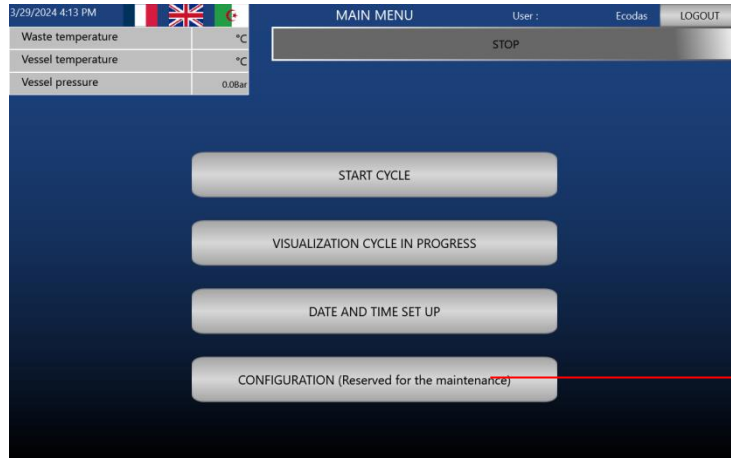

The password is « hour-minutes » (look hour and minutes)



1.4.1.5 STARTING THE STERILIZATION CYCLE

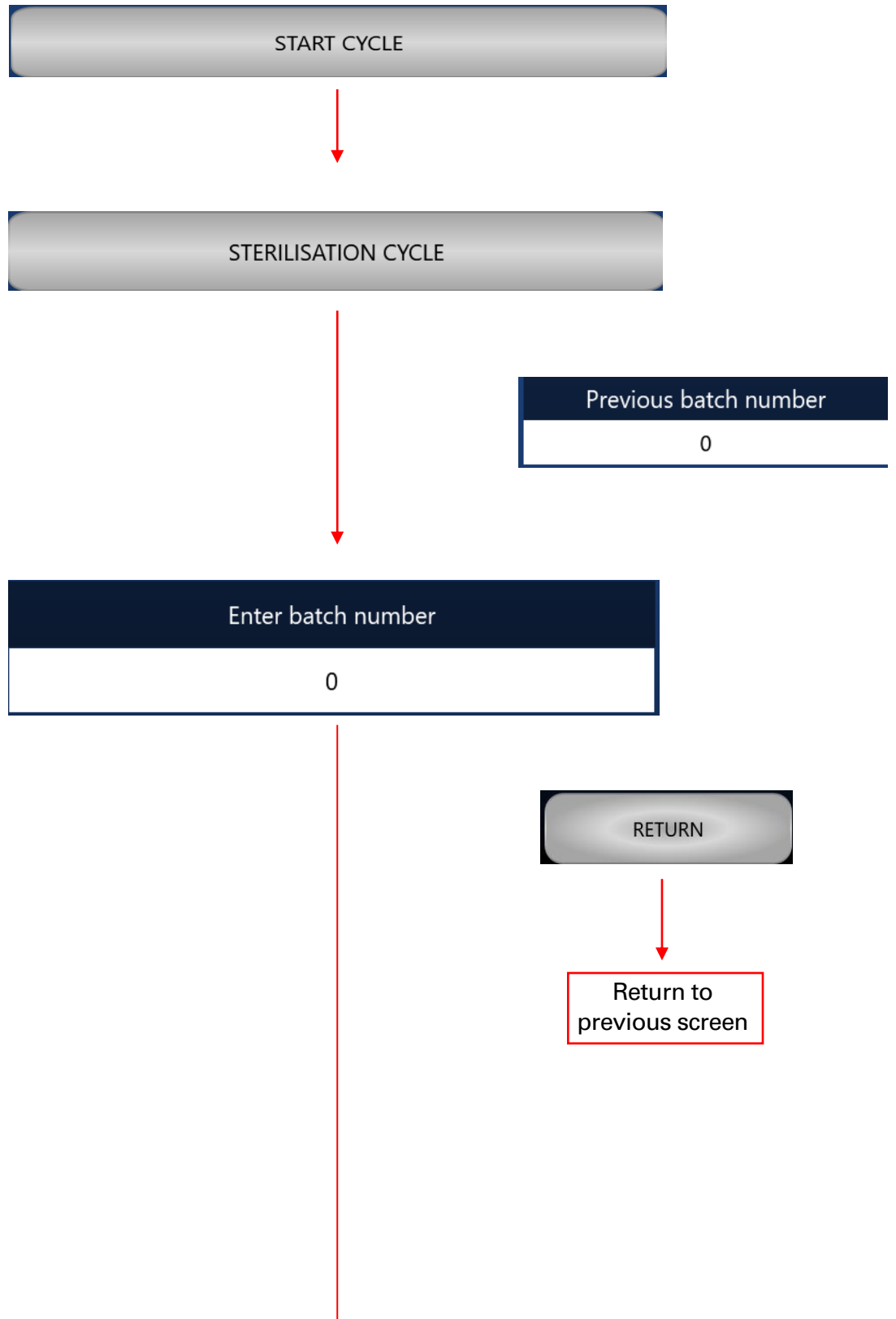



Enter the batch (ex : if the previous number is "2", enter "3")



Return to main menu

The sterilization cycle is running.

1.4.1.6 RUNNING THE SAFETY CYCLE

The Safety cycle should be launched in the following cases:

- Substantial amount of waste remains in the upper chamber and has not been shredded.
- STERILIZATION cycle has been interrupted and can not be completed.
- Before any maintenance or repairing of the machine in order to protect the maintenance technician and/or operator from risk of infection resulting from coming into contact with the waste or any inner parts of the machine.

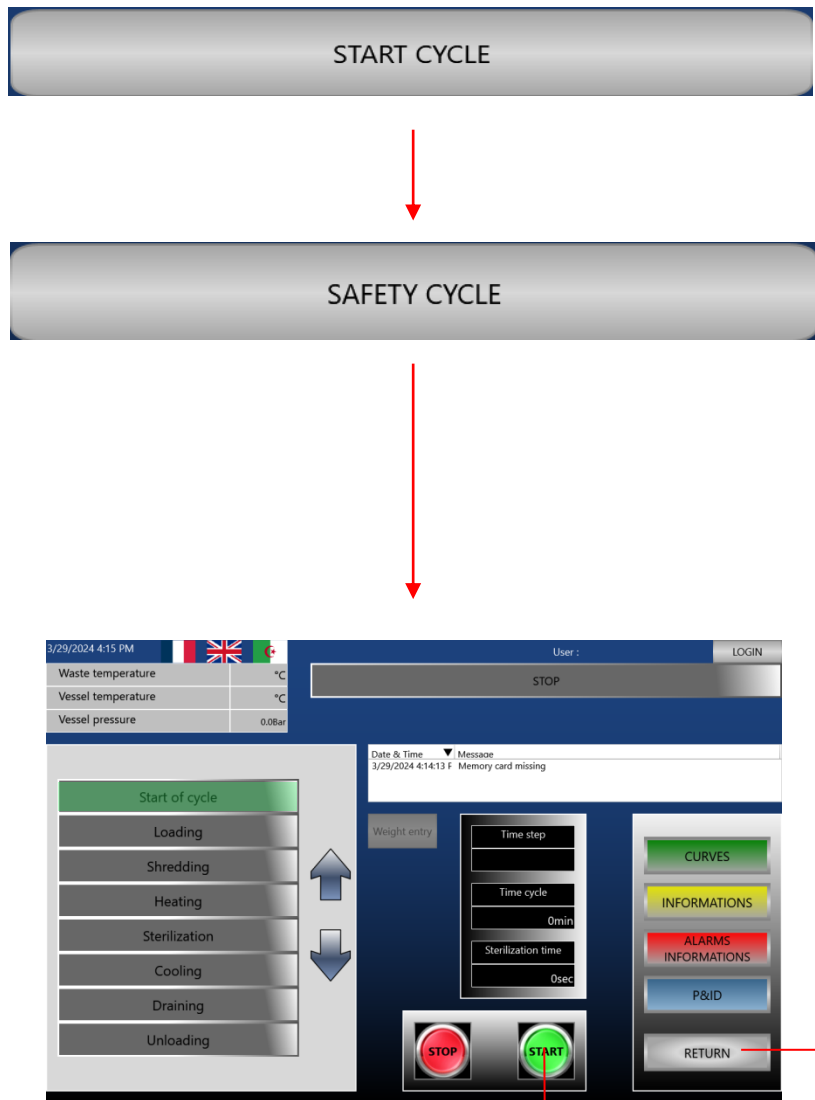

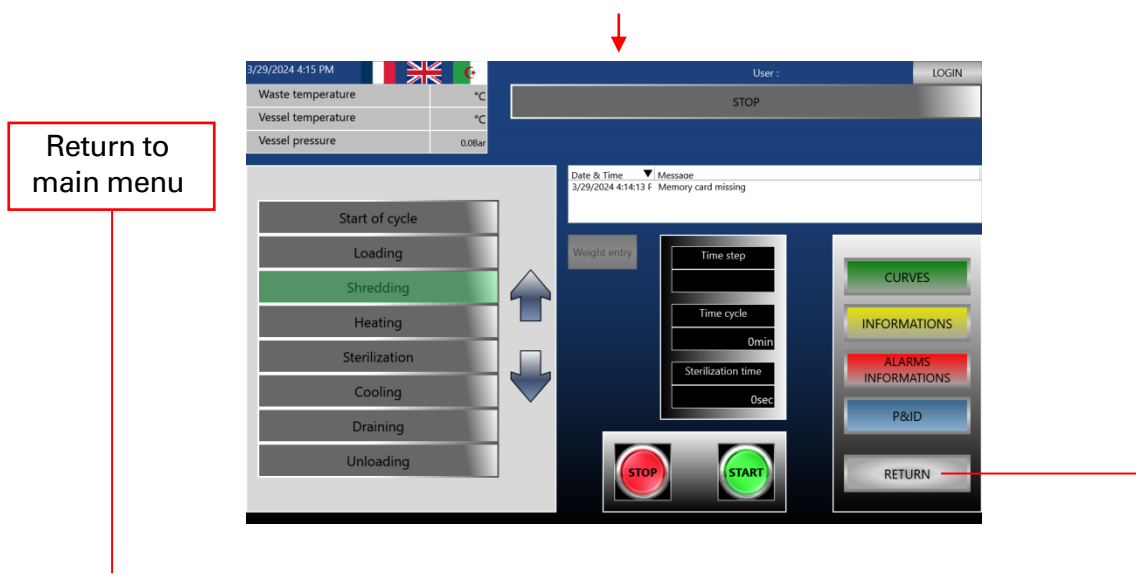

The safety cycle is running.

1.4.1.7 RUNNING THE CLEANING CYCLE

START CYCLE



CLEANING CYCLE

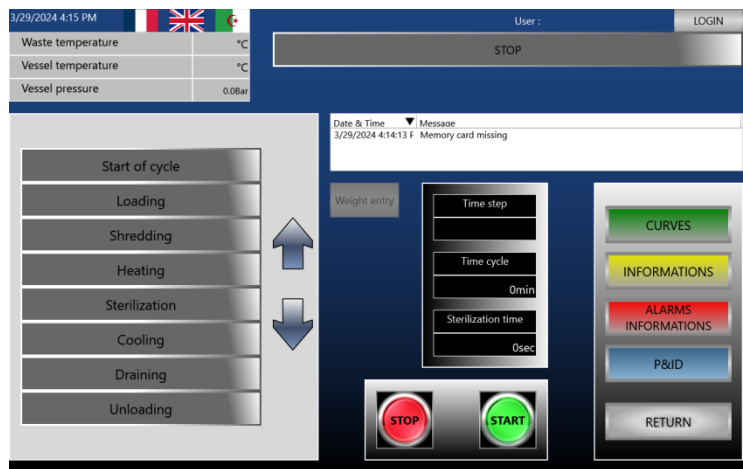

Return to main menu

The cleaning cycle is running.

1.4.1.8 RESUME A CYCLE AFTER AN EMERGENCY STOPPING OR A POWER FAILURE

VISUALIZATION CYCLE IN PROGRESS



1.4.1.9 ILLUSTRATION OF A CYCLE IN PROGRESS

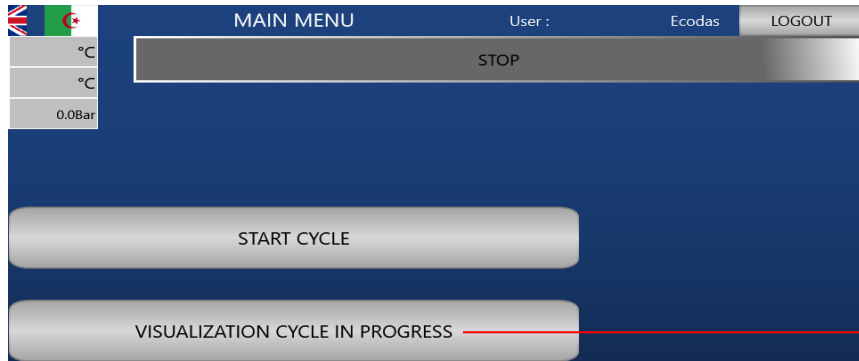

OR

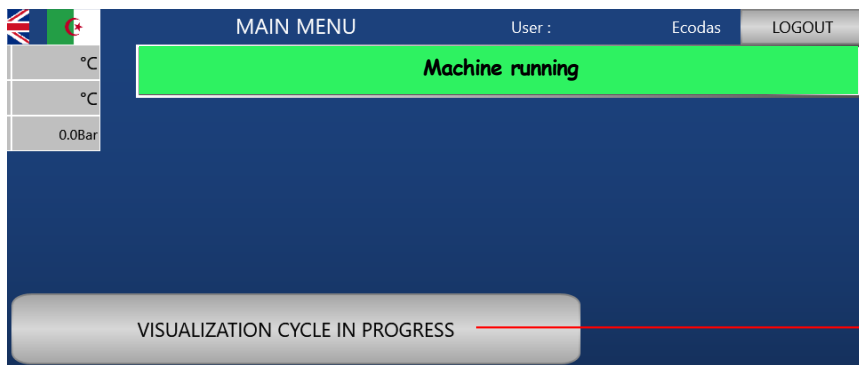

Return to main menu

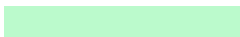
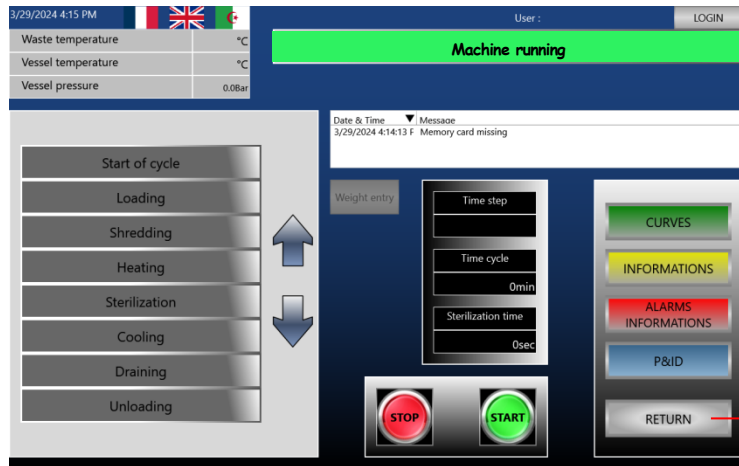

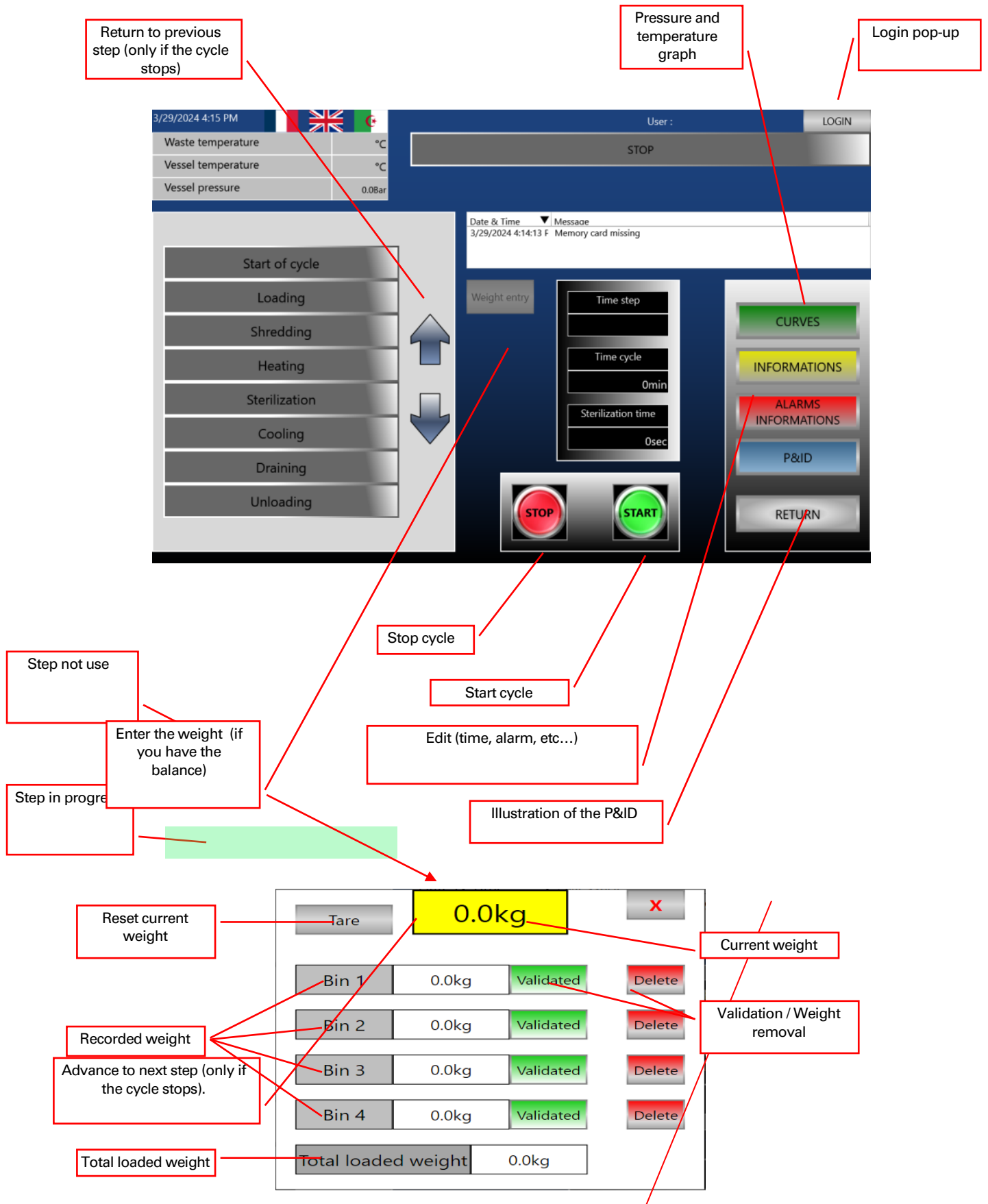

1.4.1.10 CYCLE INFORMATION

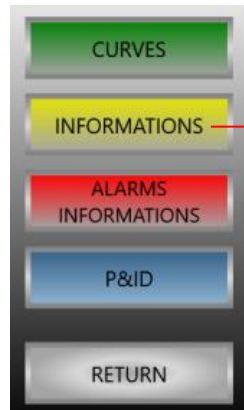

The main interface displays various operational metrics and navigation options. Callouts identify the following elements:

- Total sterilization cycles of the machine since its first operation:** Points to the 'Total value sterilization cycles' field (0).
- Current sterilizing value:** Points to the 'Sterilization value F0' field (0).
- Total time of running shredder:** Points to the 'Total time of running shredder (in hour)' field (0).
- Total operating time of the machine:** Points to the 'Machine running time (in hours)' field (0).
- Total number of use of the filter:** Points to the 'Number of filter cycle' field (0).
- Last replacement date of the filter:** Points to the 'Filter change date' field (0 / 0 / 0).
- Access to user handbook's (in PDF format):** Points to the 'User handbook' button in the 'Machine documentation' section.
- Access to electrical diagram's (in PDF format):** Points to the 'Electrical diagram of control panel' and 'Electrical diagram machine box' buttons in the 'Machine documentation' section.
- Loaded weight (running cycle):** Points to the 'Loaded weight (current cycle) (in Kg)' field (0).
- Total weight:** Points to the 'Total processed weight (in Kg)' field (0).
- Total weight processed / day:** Points to the 'Heating stop (Remaining time)' field (0sec).
- Return to previous page:** Points to the 'PREVIOUS PAGE' button.

Additional interface elements include a status bar with date/time (4/12/2024 10:58), flags, a 'User:' field, a 'LOGIN' button, a 'STOP' button, and a 'Waste temperature' / 'Vessel temperature' / 'Vessel pressure' section showing 0.0Bar.

1.4.1.11 PRESSURE AND TEMPERATURE GRAPHS



Return to previous page

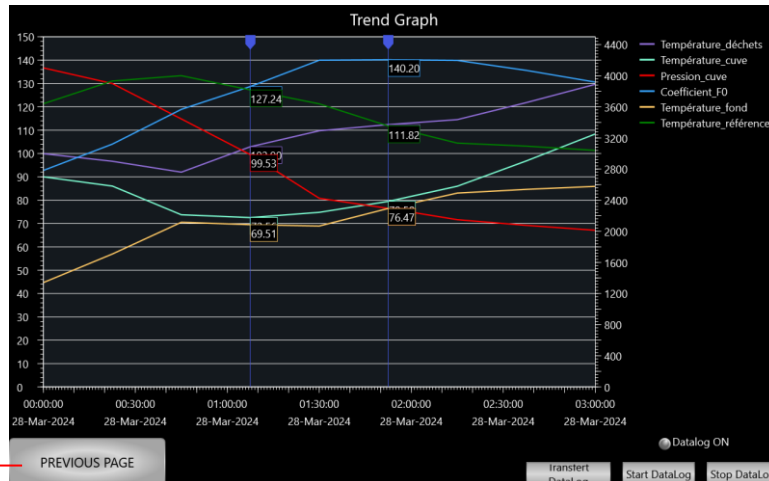

1.4.1.12 ALARMS INFORMATION

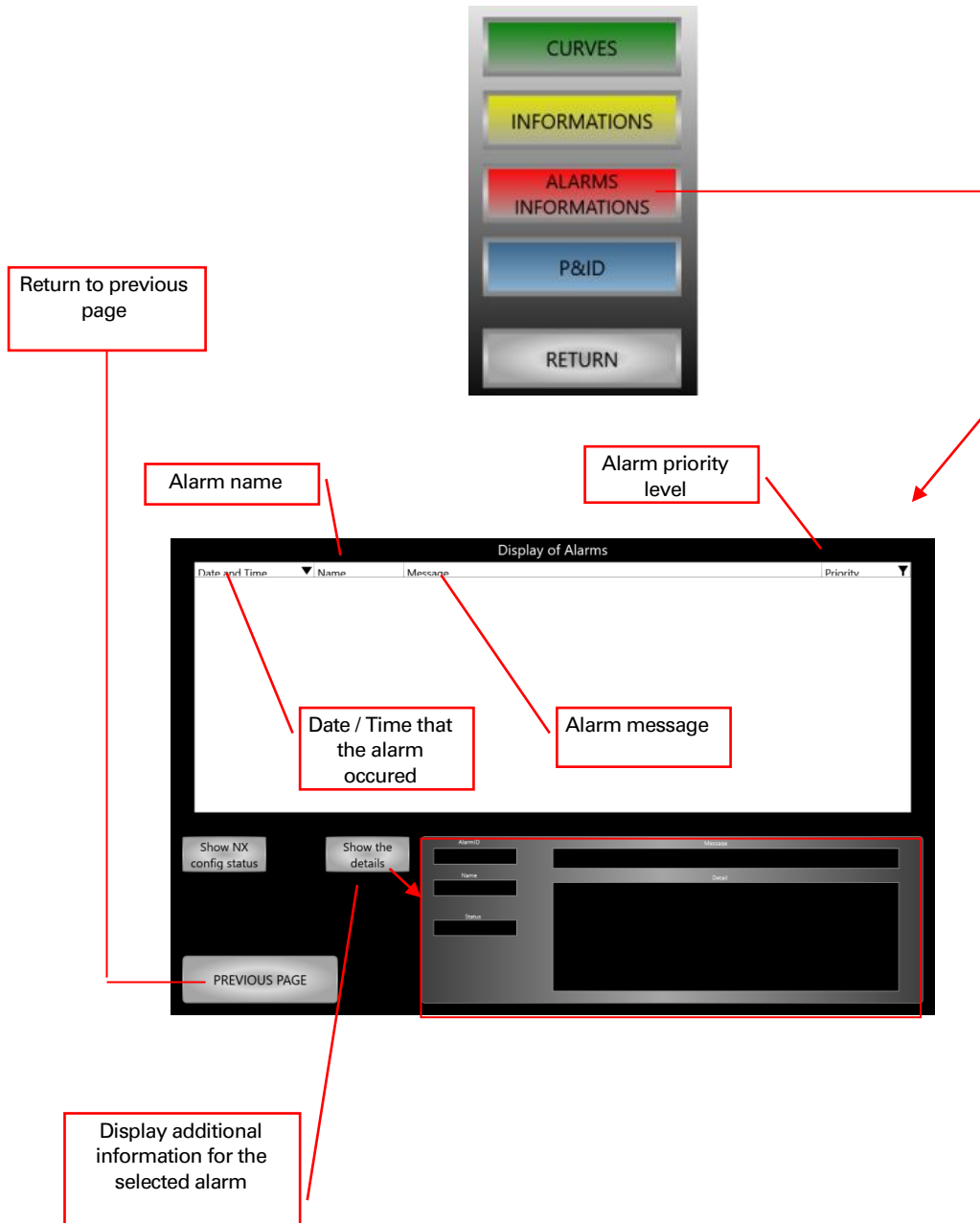

1.4.1.13 SETTING DATE AND TIME

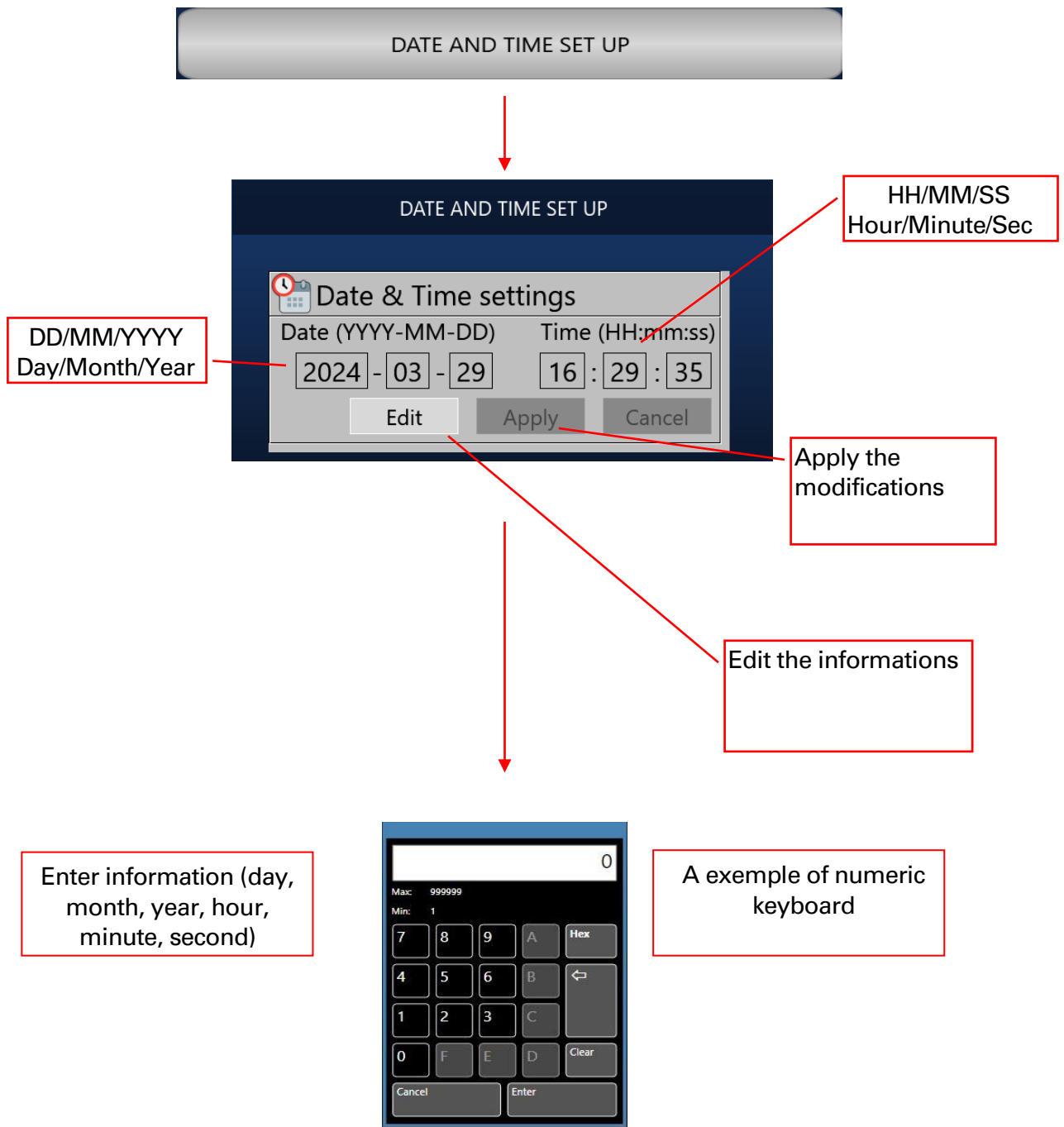

1.4.1.14 MANUAL CONTROL

CONFIGURATION (Reserved for the maintenance)



MANUAL CONTROL



3/29/2024 4:30 PM	FR	UK	IT	MANUAL CONTROL	User: Ecodas	LOGOUT
Waste temperature			°C	STOP		
Vessel temperature			°C			
Vessel pressure			0.0Bar			

SHREDDER M202

SHREDDING UNSHREDDING

PADDLE

WAY 1 WAY 2

GREASING

START / STOP

Unlocking drivers safety

P&ID

PREVIOUS PAGE RETURN NEXT PAGE

Unlock the safety driver for the maintenance.
Accessible only to level 2 users, minimum.

3/29/2024 4:30 PM	FR	UK	IT	MANUAL CONTROL	User: Ecodas	LOGOUT
Waste temperature			°C	STOP		
Vessel temperature			°C			
Vessel pressure			0.0Bar			

V1013 FLASH TANK COOLING

OPEN / CLOSE

P&ID

PREVIOUS PAGE RETURN NEXT PAGE



To unlock and open the covers, you need to activate the exhaust air « V1018 »



To open and close both covers, you must hold the button "operator call loading cover" press, located under the screen.

At the same time, push the button "open" or "close" on the screen.



To open and close both covers, you must hold the button "operator call unloading cover" press, located under the screen.

At the same time, push the button "open" or "close" on the screen.

1.4.2 REPORTS TREATMENT CYCLE

Printed cycle reports are generated only for the STERILAZATION and SAFETY cycles; the printer in the other hand is no used during the CLEANING cycle.

Printing is done at each step change then every minute when the temperature is higher than 120°C but also in case of alarm.

Printing example :

```

ECODAS T0700  CH MELUN
                Cycle 000003
    Date 07.02.23  Heure 10.52.53
-----
                Cuve  Dech  F0    Pres
                φC   φC
Chargeme 10.53.06 091   098  0000  -0.0
Broyage  10.56.16 088   093  0000  -0.0
Broyage  10.58.44 Alarme 11
Chauffag 11.10.59 088   095  0000   0.5
Chauffag 11.11.53 117   120  0000   1.5
Chauffag 11.12.53 129   132  0012   2.2
Chauffag 11.13.53 137   140  0012   2.9
Palier   11.14.05 138   141  0089   3.0
Palier   11.14.53 136   140  0089   3.0
Palier   11.15.53 137   141  0263   3.1
Palier   11.16.53 139   142  0385   3.2
Palier   11.17.53 136   141  0482   3.3
Palier   11.18.53 139   142  0604   3.3
Palier   11.19.53 138   142  0726   3.3
Palier   11.20.53 137   142  0726   3.3
Palier   11.21.53 137   141  0945   3.3
Palier   11.22.53 138   142  1067   3.4
Palier   11.23.53 137   140  1067   3.5
Palier   11.24.53 136   140  1221   3.3
Palier   11.25.53 137   141  1318   3.4
Refroidi 11.26.07 137   141  1318   3.3
Refroidi 11.26.53 128   131  1318   1.8
Vidange  11.27.48 119   123  1327   1.0
Vidange  11.27.53 119   122  1328   1.0
Decharge 11.31.13 100   099  1328  -0.0
-----
                Heure 11.40.16
    Tps du cycle 047mn
    Cycle OK
    
```

Document to be kept according to the regulations in force (from 3 to 10 years).

1.5 BASKET AND ITS LOCATION TO CARRY OUT THE BIOLOGICAL TEST

Put into the small basket provided ,the Biological indicators for steam « *Bacillus Stearothermophilus* »

Hang it on the tube inside the waste basket just under the shredder :

- Either during a sterilization cycle ,or after unloading the waste, just before closing the traps.
- Or opening, manually the unloading door and the traps .Before starting a new sterillization cycle

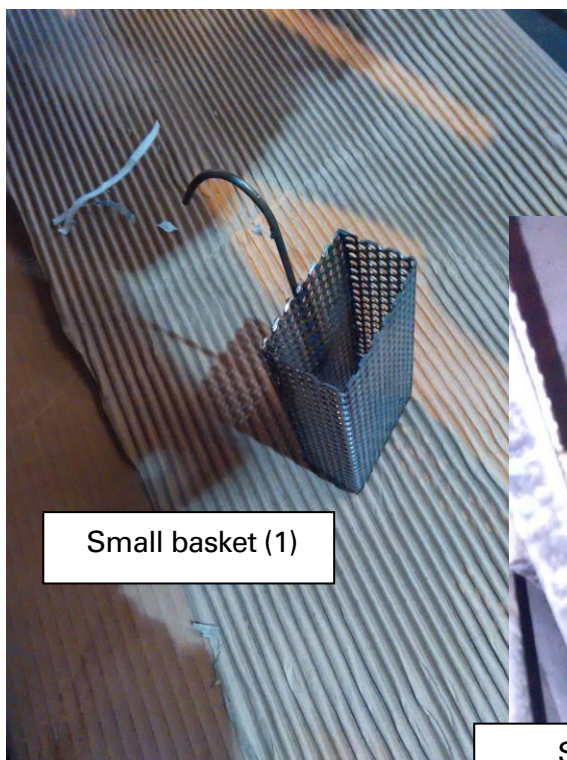

Small basket (1)

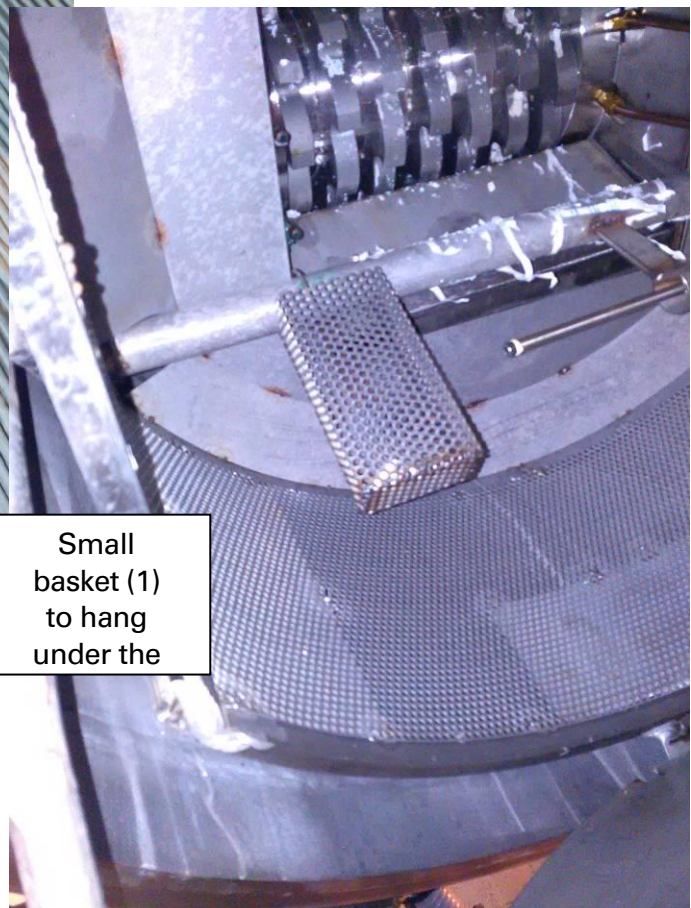

Small basket (1) to hang under the

2. OPERATION

2.1 START AUTOMATIC MODE

Turn on the main electrical power to the machine.



Restore the pressure in the pneumatic system by pressing the rearming pneumatic button for the air supply of the machine.



Check the E-stop(s) are pulled out. Rearm the safety relay by pressing the fault acknowledgment button

Start the cycle by control screen

See 1.4.1.3

2.1.1 LOADING



The loading cover is opened using the orange press button located on the control box, the lift or the control panel.

During the loading stage, the opening of loading cover is authorized, when the orange indicator flashes. Press on the flashing orange button to open the cover.

Completely fill the upper chamber (manually or by using the lift). A scrolling message appears on the screen, informing the operator that the lift can be used. Once the operator has loaded the required number of bins, the program doesn't allow the use of the lift anymore.

Close the upper cover by pressing the flashing orange button. Then, the flashing orange light stops and a green indicator lights up, indicating that the cycle is in progress.

2.1.1.1 CYCLE RUNNING

The treatment cycle runs in the automatic mode and No operator action is required.

ATTENTION: For safety reasons, the rotation of the shredder is prolonged for a few minutes in order to clean-up the remaining shredded waste between the knives. This waste had been sterilized, does not present any danger and will be cleared out with the afterward load.

2.1.2 UNLOADING



The unloading cover is opened when using the orange push button on the control panel.

1. When the alarm light is flashing orange, the operator must push on the flashing orange button once to open the unloading cover.
2. The operator must manually position the cart under the vessel to unload.
3. The operator must push on the flashing orange button once to open the traps.
4. The operator must push on the flashing orange button once to close the traps.
5. Once the cart is cleared out of the way, the operator must push on the flashing orange button once to close the unloading cover.

Once these operations are executed, then a complete treatment cycle has been achieved. The green light goes off.

2.1.3 STOP THE MACHINE



- Through the screen: with the STOP button (see "running cycle" screen), in the event of a fault or at the end of the cycle.
- Through the emergency stop button.
- Through the main disconnect switch.
- Through the compressed regulator air valve.

IMPORTANT: You can only turn OFF the main disconnect switch and perform the lockout procedure if the treatment cycle is completed.



2.1.4 FUNCTIONAL CONTROL

During a cycle, the following parameters are displayed on the HMI touch screen:

- Step time
- Temperature in the lower chamber
- Temperature at the core of the waste
- Sterilizing value
- Machine pressure
- Number of executed cycles by the machine

The different sensors measure:

- Temperature in the lower chamber **106**
- Temperature at the core of the waste **304**
- Machine pressure **108**

The limit switches make it possible to control the positions of the moving parts of the machine:

- FC303.O - FC303.C Traps
- FC1018 Open vent valve
- FC1011-1 Steam network valve CLOSE
- FC1021.O - FC1021.C Loading cover belt OPEN - CLOSE
- FC1025.O - FC1025.C Loading cover UNLOCKED - LOCKED
- FC1026.O - FC1026.C Loading cover OPEN - CLOSE
- FC1042.O - FC1042.C Unloading cover UNLOCKED - LOCKED
- FC1043.O - FC1043.C Unloading cover belt OPEN - CLOSE
- FC1045.O - FC1045.C Unloading cover OPEN - CLOSE

Pressure sensor to control:

- FC11 Pressure in the air network
- FC1023.I Loading cover gasket INFLATED
- FC1046.I Unloading cover gasket INFLATED

Level sensor

- N107 Low level of draining

Pressure sensor

- P50 Switch 50 mbar

The printed report discloses the temperature inside the waste, the temperature in the lower chamber, the pressure, the sterilizing value, and the time and date of the executed cycles.

2.1.5 DISPLAY MESSAGES

TYPE SIGNALISATION	SIGNIFICATION	CONSEQUENCE
White light	Control panel ON	
Flashing orange light beacon	Operator intervention is required	Execution to validate the change to the following stage of the cycle and to open/close the covers and the traps.
Green light beacon	Machine cycle is running	Wait for the end of the cycle to begin a new load
Flashing red light beacon	Machine alarm	Follow the instructions displayed on the screen
Siren	Machine alarm	

2.2 MACHINE SAFETY

Various devices guarantee the protection at the openings of the covers, the overpressure as well as the tightness of the machine:

2.2.1 UNLOCKING COVERS

Vent valve (rep V1018) with sensor for open valve detection (ref FC1018)

Sensor for detecting the presence of water in the bottom of the machine (rep N107)

Pressure switch set at 50mbars (rep P50)

To be able to unlock the covers, we check that:

- the vent valve has been open for at least 30 seconds
- the water sensor does not detect water
- the pressure inside the tank is less than 50mbars

These elements constitute the safety part of the program.

In automatic operating mode via the PLC, there is added a second control of the pressure set at 100mbars (by a 4-20mA analog pressure sensor (rep 108)) and a temperature control set to 105 ° C (by a temperature sensor Pt100 (rep 106))

2.2.2 SEALING OF THE MACHINE

The supply of compressed air passes through a shut-off solenoid valve (rep EV11) before entering the pneumatic distribution box.

A pressure switch (ref FC11) mounted on this solenoid valve cuts it if the air pressure is less than 4.5 bar. This pressure switch then triggers an alarm which is displayed on the control screen and the machine is automatically switched off.

The seal between the tank and the removable covers is ensured by gaskets pushed with compressed air.

On each seal, a pressure switch (rep FC1023.I and rep FC1046.I) makes it possible to check that the thrust pressure is greater than or equal to 5 bars. Otherwise an alarm is displayed on the control screen and the machine is switched off automatically.

In the event of a power failure, a bypass (rep EV1) makes it possible to continue sending air at the gaskets to maintain the watertightness.

2.2.3 STEAM PRESSURIZATION/OVERPRESSURE

The steam pressurization is only possible when the covers are closed et locked.

A loop control composed of coded sensors (type 4) and safety cards (API) monitor the positions of the cover before any injection of steam pressure.

The steam network is composed of 2 separate steam valves with a separate pneumatic control.

- A valve for the regulation, équipé with a limit switch (NC (Normally Close) position).
- A circuit isolation valve .

A safety valve (or two depending on the model) calibrated at 4.5 bar is installed on the machine.

2.2.4 STOP AND CONTROL

An emergency stop button (or two depending on the model) can stop the machine in case of problems. It cuts the inputs of safety card (U-4) which itself cuts the power and all the control. The machine stops and the seal is maintained.

Once the safety relay is reset, the cycle resumes at the point where it was stopped.

All locked and closed position sensors, such as:

- closed loading and unloading covers (rep FC1026.C and rep FC1045.C)
- closed loading and unloading belts (rep FC1021.C and rep FC1043.C)
- locked loading and unloading belts (rep FC1025.C and rep FC1042.C)

are doubled and mounted in series. All these sensors are monitored by the PLC. As soon as one of them is lost, the cycle stops automatically and the alarm associated with this sensor appears on the control screen.

A visual check of the pressure and the temperature can be carried out using the gauge and the thermometer mounted on the machine as well as through the control screen.

The opening and closing actions of the covers are performed by the operator via the orange operator call button. The button must be maintained throughout the manoeuvre. Otherwise the covers will stop in position.

2.2.5 INTERVENTION IN THE MACHINE

After performing the safety cycle, you have to open the high and low covers to let the machine cool down quickly.

Please check the temperature on the thermometer, it must be below 30°C.

- set up the locking elements of the top and bottom cover.
- turn off the control panel and place the padlock on the power disconnecter.
- close the air inlet valve and place the padlock on the valve.
- close the steam inlet valve and place the padlock on the valve (customer side).

2.2.6 INTERVENTION DURING A SHREDDER BLOCKING

The shredder functionment is automatic. When the shredder is overloaded, the shafts rotation is reverse during 5 secondes, to clear the excess waste generated.

If there are 3 overloads in less than 1 minute, the machine engages the safety alarm, stops the motors rotation and the steam injection. The operator call is activated and the siren sounds. The operator must come to control box level to solve the default (alarm 15).

By solving the default, the operator authorizes the shredder restart. The aim being to make the distinction between a mechanical noise due to a metal part (protesis) or due to compact waste (tissues or filters). The operator informs his service manager who will take the responsibility to stop the cycle and to launch a safety cycle.



Before launching the safety cycle, it will be necessary to carry out an initial electrical and mechanical diagnosis:

- The motors supply voltage.
- The current absorbed.
- The alarm number is displayed on any driver screen V202 and V203 (only for the T2000 machine).
- The drivers status and the eventually fault code.

After performing the safety cycle, both covers must be opened to let the machine cool down quickly.

Please check the temperature on the thermometer (< 30°C).



- set up the locking elements of the top and bottom cover.
- turn off the control panel and place the padlock on the main power disconnecter.
- close the air inlet valve and place the padlock on the valve.

Wear the PPE before intervention.

Remove the sterilized waste located above the shredder using a hook or a shovel.

Remove the metal part causing the blocking.

Close the cover and carry out a rotation test in the unshredding direction in a first place, then in the shredding direction in a second time.

If the problem is solved, return to the initial position allowing you to launch an automatic cycle.

It is recommended to run a automatic sterilization cycle without waste to check if the shredder is working properly.

3. MAINTENANCE

3.1 GENERAL INSTRUCTIONS

Spare parts and accessories not supplied by ECODAS SAS have not been tested, and therefore do not comply with ECODAS SAS standards.

The implementation of such products can in some circumstances modify negatively the construction properties of the ECODAS SYSTEM and thus be detrimental to personal safety and/or machine reliability.

ECODAS SAS accepts no responsibility for damages that may result from using such non-original parts or accessories, and denounces all warranties.

During the maintenance and repairs, particular attention must be directed to the safety instructions contained within. All the instructions must be imperatively followed.

The maintenance fault can stop the run of the machine and cause damages that may require major repairs and important immobilizations.

It is important that a good quality lubricant be selected to insure maximum life is obtained from the gear drive. Therefore, only those oils identified in these instructions as approved oils may be used in these gear drives. Use of any other oil must be approved by ECODAS SAS.

It is strictly not recommended to clean the machine and around the machine with a pressure washer (type KARCHER).

ATTENTION: ECODAS SAS assumes no responsibility for use or reliability of accessories on its equipments that are not supplied by ECODAS SAS. ECODAS SAS makes no warranties, either express or implied, regarding the described parts, their merchantability or their fitness for any particular purpose.

ATTENTION: ECODAS SAS will take no responsibility for any accidents, injuries to personnel or damage to the machine if the equipment is installed, operated or serviced without following the instructions in this manual.

3.2 PREVENTIVE MAINTENANCE

3.2.1 ORDERS TO RESPECT

Only qualified personnel familiar with ECODAS SYSTEM can perform maintenance and repairs of the system. Particular attention must be directed again to the hygiene and safety instructions contained in this manual. Such instructions must be respected and enforced during all operations.

A STERILIZATION cycle with an empty vessel must be launched before any maintenance or service intervention on the machine.

The power must be removed from the machine by turning OFF the main disconnect switch and lock out the power source on the control panel for all maintenance interventions on the sterilization installation.

A preventive maintenance must be executed regularly and in accordance with ECODAS SAS instructions. These interventions contribute to the optimum operation ECODAS SYSTEM and avoid the risks of machine failures which are usually long and costly.

3.2.2 PREVENTIVE MAINTENANCE SCHEDULE

Frequency	Action
Every cycle	Check waste presence on loading and unloading seals
	Clean the paddle assembly
	Clean unloading traps
	Clean the waste temperature probe
Every day	Clean the U-shaped flange
	Clean the draining grid
	Check the grease level of the shredder greasing pump
	Refill with recommended grease if it's necessary
	Check that there is no grease leakage at the connections flexible hose
Every week	Remove and clean the covers seals
	Clean the grooves of the seals
	Clean the bottom of the cover
	Clean the lower level of the vessel
	Clean the shredder
	Clean basket
	Check the oil level in the lubricator (FRL system) and refill with oil if necessary (oil for pneumatic circuit)
Every months	Check the oil level of the shredder gearbox and refill with oil if necessary
	Clean the fan guard/filter of the control panel
Every 6 months	Check the oil level of paddle gearbox and refill with oil if necessary
Every year or if Alarm 12 is on	Change the filter cartridge (filter optional)
Once a year	<p>Lubricate the lift bearings.</p> <p>Lubricate the lift chains with appropriate greass. It's not necessary to dismantle the chains.</p> <p>Check the tightening of the reducers (shredder, paddle and lift).</p>
4000 cycles 6000 cycles 8000 cycles	Shredder replacement : - T150 / T2000 - T1000 / T700 - T300

4. TROUBLESHOOTING

4.1 DISPLAY ALARM MESSAGES

4.1.1 SUMMARY TABLE

MACHINE ALARMS :		
Alarm	Fault message	Problem indication
1	WASTE TEMPERATURE PROBE FAULT	Waste temperature <= 0°C Or Waste temperature >= 150°C Or Error code Pt100 card
2	VESSEL TEMPERATURE PROBE FAULT	Lower chamber temperature <= 0°C Or Lower chamber temperature >= 150°C Or Error code Pt100 card
3	VESSEL PRESSURE PROBE FAULT	Vessel Pressure <= -1bar Or Vessel pressure >= +5 bars Or Error code analog card
4	VESSEL BOTTOM TEMPERATURE PROBE FAULT	Vessel bottom temperature <=0°C Or Vessel bottom temperature >= 150°C Or Pt100 card error code
5	COMPRESSED AIR SUPPLY FAULT	Air pressure system < + 4.5bars
6	SHREDDER FAULT	Frequency inverter fault
7	EMERGENCY STOP / MANUAL MODE	***** *****
8	UNLOADING SEAL COVER FAULT	Seal pressure < +5 bars
9	LIMIT SWITCH OF UNLOADING COVER FAULT	***** *****
10	LIMIT SWITCH OF LOADING COVER FAULT	***** *****
11	PADDLE ASSEMBLY FAULT	Frequency inverter fault
12	REPLACING FILTER CARTRIDGE (filter optional)	After 25 applications
13	*FREE*	***** **
14	LIMIT SWITCH OF TRAPS FAULT	***** *****
15	SHREDDER OVERLOADING FAULT	Motor load > Imaxi

16	LOADING SEAL COVER FAULT	Seal pressure < +5 bars
17	MACHINE LOW LEVEL FAULT	***** *****
18	STEAM FAULT	Heating is in progress for more than 10 min. and waste temperature < 136°C Or Standing stage is in progress and waste temperature < 136°C
19	SEAL LEAKAGE FAULT	Vessel pressure >= +1,2 bar during shredding stage
20	SHREDDER LUBRICATION FAULT	Limit switch FC210
22	VACUUM PUMP FAULT	Motor load > Rated current
23	COOLING STAGE FAULT	Cooling time > 15min.
24	MOTOREDUCTOR LIFT FAULT	Frequency inverter fault Or Breaker failure
25	FLASH TANK TEMPERATURE PROBE FAULT	Flash tank temperature <= 0°C Or Flash tank temperature >= 150°C Or Error code Pt100 card
26	FLASH TANK COOLING FAULT	Temperature > T°C max
27	MANUAL COMMAND	*****
28	UNLOCK THE INVERTERS SAFETY	*****
32	BOILER FAULT (option)	*****
33	BOILER PRESSURE PROBE FAULT (option)	Pressure boiler <= -1 bar Or Pressure boiler >= +10 bars Or Error code analogic card
35	TERMINAL OPERATOR BATTERY FAULT	5 years
37	PLC BATTERY FAULT	5 years
38	POWER FAILURE DURING A TREATMENT CYCLE	*****
39	ATTENTION SWITCHS 5 AND 6 ARE OFF	*****
40	UNLOADING COVER UNLOCKING FAULT	*****
41	CHAIN SECURITY FAULT N107	CHECK N107
42	CHAIN SECURITY FAULT P50	CHECK P50
43	CHAIN SECURITY FAULT V1018	CHECK FC1018 AND VALVE V1018
44	OPENING LOADING BELT FAULT	***** *
45	LIFT USE AUTHORIZATION FAULT	CHECK FC900

4.1.2 ALARM INSTRUCTIONS

ALARM 1:

Displayed message: **WASTE TEMPERATURE PROBE FAULT**

Possible cause of the alarm:

- The waste temperature probe 304 located inside the vessel is not operational.
- The connection of the temperature probe is faulty.

Results on the sterilization cycle:

- In between two sterilization cycles, the PLC will allow the start of a new cycle only if the problem is fixed.
- During the shredding stage the cycle continues, and the temperature is monitored by the temperature probe 106 located in the lower chamber of the vessel.
- During the heating stage the cycle continues, and the temperature is monitored by the temperature probe 106 located in the lower chamber of the vessel.
- During the standing stage the cycle continues, and the temperature is monitored by the temperature probe 106 located in the lower chamber of the vessel.
- During the cooling stage the cycle continues, and the temperature is monitored by the temperature probe 106 located in the lower chamber of the vessel.
- During the unloading stage the cycle continues.

Operator's instructions:

- Complete the cycle then inform the maintenance department.
- The displayed message can be deleted by pushing **ACKNOWLEDGE** button on HMI touch screen.
- The Flashing warning red light can be stopped by pressing the **FAULT RESET** button.

Maintenance department guide:

- The resistance at the end of the temperature probe wire: must be around 100 Ohms.
- Check the wiring between the temperature probe and the machine box.
- Change the defective probe.
- Contact ECODAS technical support group.

ALARM 2:

Displayed message: ***VESSEL TEMPERATURE PROBE FAULT***

Possible cause of the alarm:

- The temperature probe 106 located inside the vessel is not operational.
- The connection of the temperature probe is faulty.

Results on the sterilization cycle:

- In between two sterilization cycles, the PLC will allow the start of a new cycle only if the problem is fixed.
- During the shredding stage the cycle continues.
- During the heating stage the cycle continues.
- During the standing stage the cycle continues.
- During the cooling stage the cycle continues, and the temperature is monitored by the waste temperature probe 106.
- During the unloading stage the cycle continues

Operator's instructions:

- Complete the cycle then inform the maintenance department.
- The displayed message can be deleted by pushing **ACKNOWLEDGE** button on HMI touch screen.
- The Flashing warning red light can be stopped by pressing the **FAULT RESET** button.

Maintenance department guide:

- The resistance at the end of the temperature probe wire: must be around 100 Ohms.
- Check the wiring between the temperature probe and the machine box.
- Change the defective probe.
- Contact ECODAS technical support group.

ALARM 3:

Displayed message: ***PRESSURE PROBE FAULT***

Possible cause of the alarm:

- Vessel pressure probe 108 is not operational.
- The connection of the vessel pressure probe 108 is faulty.

Results on the sterilization cycle:

- In between two sterilization cycles, the PLC will allow the start of a new cycle only if the problem is fixed.
- During the shredding stage the cycle continues.
- During the heating stage the cycle continues.
- During the standing stage the cycle continues.
- During the cooling stage the cycle continues.
- During the unloading stage the cycle continues

Operator's instructions:

- Complete the cycle then inform the maintenance department.
- The displayed message can be deleted by pushing **ACKNOWLEDGE** button on HMI touch screen.
- The Flashing warning red light can be stopped by pressing the **FAULT RESET** button.

Maintenance department guide:

- Check the wiring between the pressure probe and the machine box.
- Change the defective probe.
- Contact ECODAS technical support group.

ALARME 4:

Displayed message: ***BOTTOM TANK TEMPERATURE PROBE FAULT***

Possible cause of the alarm:

- The temperature probe 110 located inside the vessel is not operational.
- The connection of the temperature probe is faulty.

Results on the sterilization cycle:

- Between two sterilization cycles, the PLC will allow to start a new cycle only if the problem is fixed.
- During the shredding stage the cycle continues.
- During the heating stage the cycle continues.
- During the standing stage the cycle continues.
- During the cooling stage the cycle continues, and the temperature is monitored by the waste temperature probe 110.
- During the unloading stage the cycle continues

Operator's instructions:

- Complete the cycle then inform the maintenance department.
- The displayed message can be deleted by pushing **ACKNOWLEDGE** button on the HMI touch screen.
- The flashing warning red light can be stopped by pressing the **FAULT RESET** button.

Maintenance department guide:

- The resistance located at the end of the temperature probe wire must be around 100 Ohms.
- Check the wiring between the temperature probe and the machine box.
- Change the defective probe.
- Contact ECODAS technical support group.

ALARM 5:

Displayed message: ***COMPRESSED AIR SUPPLY FAULT***

Possible cause of the alarm:

- Air compressor generator OFF.
- Inlet compressed air valve closed.
- The connection of the air pressure regulator is damaged.
- Air pressure regulator FC11 is not operational.
- Compressed air control valve EV11 is not operational.

Results on the sterilization cycle:

- In between two sterilization cycles, the PLC will allow the start of a new cycle only if the problem is fixed.
- During the shredding stage the cycle is idle for 10 minutes.
- During the heating stage the cycle is idle for 10 minutes.
- During the standing stage the cycle is idle for 10 minutes.
- During the cooling stage the cycle is idle for 10 minutes.
- During the unloading stage the cycle is idle for 10 minutes.
- After this time delay the appliance decompresses through the filter.

Note: The pressure in the inflatable covers seals is maintained, and all the valves remain in their state just prior to the fault condition.

Operator's instructions:

- Complete the cycle then inform the maintenance department.
- The displayed message can be deleted by pushing **ACKNOWLEDGE** button on HMI touch screen.
- The Flashing warning red light can be stopped by pressing the **FAULT RESET** button.

Maintenance department guide:

Check:

- Air compressor generator is on.
- Inlet compressed air valve is open.
- Enough air pressure in the infeed air system.
- The proper operation the air pressure regulator FC11.
- The wiring between the air pressure regulator FC11 and the electrical panel.
- The proper operation the control valve EV11.

- Contact ECODAS technical support group.

ALARM 6:

Displayed message: **SHREDDER FAULT**

Possible cause of the alarm:

- Mechanical jam of the shredder.
- Fuses F202 & F203 (only T2000) are damaged.
- Frequency converter V202 & V203 (only T2000) is out of order.
- The motor drive M202 & M203 (only T2000) is out of order.

Results on the sterilization cycle:

- During the loading stage the cycle continues.
- During the shredding stage the cycle is idle.
- During the heating stage the cycle continues.
- During the standing stage the cycle continues.
- During the cooling stage the cycle continues.
- During the unloading stage the cycle continues.

Operator's instructions:

- Inform the maintenance department.
- The displayed message can be deleted by pushing **ACKNOWLEDGE** button on HMI touch screen.
- The Flashing warning red light can be stopped by pressing the **FAULT RESET** button.

Maintenance department guide:

Check:

- If the fuses F200 & F203 (only T2000) are damaged.
- Check the frequency inverter V202 & V203 (only T2000).
- The wiring between the motor drive and the electrical panel.

- Otherwise launch the **SAFETY** cycle (138°C during 30 minutes) and contact ECODAS technical support group.

ALARM 7:

Displayed message: ***EMERGENCY STOP / MANUAL MODE***

Possible cause of the alarm:

- The emergency stop has been enabled.

Results on the sterilization cycle:

- In between two sterilization cycles, the PLC will allow the start of a new cycle only if either conditions are met:
 - The Emergency stop is disabled and there is enough line pressure.
 - The appliance is on auto mode.
- During the loading stage the cycle stops.
- During the shredding stage the cycle stops.
- During the heating stage the cycle stops.
- During the standing stage the cycle stops.
- During the cooling stage the cycle stops.
- During the unloading stage the cycle stops.

Note: In the case of an E-Stop the pressure in the inflatable covers seals is maintained, all the valves close, and the air cylinders remain in their states prior to the fault condition.

Instructions to follow:

- If the machine has been in an E-stop condition or in manual mode, only a maintenance department personal with the key switch can reset and restart the machine.
- The displayed message can be deleted by pushing **ACKNOWLEDGE**.

ALARM 8:

Displayed message: ***UNLOADING SEAL COVER FAULT***

Possible cause of the alarm:

- Dirty seal.
- Inflatable cover seal not operational.
- Insuffisant air pressure supply.
- The air pressure seal limit switch FC.1046.I is not operational.

Results on the sterilization cycle:

- In between two sterilization cycles, the PLC will allow the start of a new cycle only if the problem is fixed.
- During the shredding stage the cycle is idle for 10 minutes.
- During the heating stage the cycle is idle for 10 minutes.
- During the standing stage the cycle is idle for 10 minutes.
- During the cooling stage the cycle is idle for 10 minutes.
- During the unloading stage the cycle is idle for 10 minutes.
- After this time delay the appliance decompresses through the filter.

Note: All the valves close, and the air cylinders remain in their states prior to the fault condition.

Operator's instructions:

- Complete the cycle then inform the maintenance department.
- The displayed message can be deleted by pushing **ACKNOWLEDGE** button on HMI touch screen.
- The Flashing warning red light can be stopped by pressing the **FAULT RESET** button.

Maintenance department guide:

Check:

- The compressed air must be rearmed.
- The compressed air inlet valve must be open.
- Le réseau d'alimentation en air doit être sous pression.
- The proper operation of the air pressure seal limit switch FC1046.I located on the machine box.
- The connection of pressure contact.
- Clean the seal, replace if necessary.
- Contact ECODAS technical support group.

ALARM 9:

Displayed message: ***LIMIT SWITCH OF UNLOADING COVER FAULT***

Possible cause of the alarm:

- The unloading cover is not closed properly.
- The unloading cover is not locked.
- The unloading cover limit switches closed FC1045.C-1 and/or FC1045.C-2 are not positioned properly, is not operational, the wiring is faulty.
- The unloading cover belt limit switches closed FC1043.C-1 and/or FC1043.C-2 are not positioned properly, is not operational, the wiring is faulty.is not operational.
- The unloading cover limit switches locked FC1042.C-1 and/or FC1042.C-2 are not positioned properly, is not operational, the wiring is faulty.

Results on the sterilization cycle:

- In between two sterilization cycles, the PLC will allow the start of a new cycle only if the problem is fixed.
- During the shredding stage the cycle is idle.
- During the heating stage the cycle is idle.
- During the standing stage the cycle is idle.
- During the cooling stage the cycle is idle.
- During the unloading stage the cycle continues.

Operator's instructions:

- Complete the cycle then inform the maintenance department.
- The displayed message can be deleted by pushing **ACKNOWLEDGE** button on HMI touch screen.
- The Flashing warning red light can be stopped by pressing the **FAULT RESET** button.

Maintenance department guide:

Check:

- The proper closing of the unloading cover.
- The unloading cover is securely locked.
- The unloading cover limit switches FC1045.C-1 and/or FC1045.C-2 are properly closed.
- The unloading cover belt limit switches FC1043.C-1 and/or FC1043.C-2 are properly closed.
- The unloading cover limit switches FC1042.C-1 and/or FC1042.C-2 are securely locked.
- The wiring of the unloading cover limit switches closed.C-1 and/or FC1045.C-2.
- The wiring of the unloading cover belt limit switches closed FC1043.C-1 and/or FC1043.C-2.
- The wiring of the unloading cover limit switches locked FC1042.C-1 and/or FC1042.C-2.
- Replace the limit switch, if is defective.
- Contact ECODAS technical support group.

ALARM 10:

Displayed message: ***LIMIT SWITCH OF LOADING COVER FAULT***

Possible cause of the alarm:

- The loading cover is not closed properly.
- The loading cover is not locked.
- The loading cover limit switches closed FC1026.C-1 and/or FC1026.C-2 are not positioned properly, is not operational, the wiring is faulty.
- The loading cover belt limit switches closed FC1021.C-1 and/or FC1021.C-2 are not positioned properly, is not operational, the wiring is faulty.
- The loading cover limit switches locked FC1025.C-1 and/or FC1025.C-2 are not positioned properly, is not operational, the wiring is faulty.

Results on the sterilization cycle:

- In between two sterilization cycles, the PLC will allow the start of a new cycle only if the problem is fixed.
- During the shredding stage the cycle is idle.
- During the heating stage the cycle is idle.
- During the standing stage the cycle is idle.
- During the cooling stage the cycle is idle.
- During the unloading stage the cycle is idle.

Operator's instructions:

- Complete the cycle then inform the maintenance department.
- The displayed message can be deleted by pushing **ACKNOWLEDGE** button on HMI touch screen.
- The Flashing warning red light can be stopped by pressing the **FAULT RETURN** button.

Maintenance department guide:

Check:

- The proper closing of the loading cover.
- The loading cover is securely locked.
- The loading cover limit switches FC1026.C-1 and/or FC1026.C-2 are properly closed.
- The loading cover belt limit switches FC1021.C-1 and/or FC1021.C-2 are properly closed.
- The loading cover limit switches FC1025.C-1 and/or FC1025.C-2 are securely locked.
- The wiring of the loading cover limit switches closed FC1026.C-1 and/or FC1026.C-2.
- The wiring of the loading cover belt limit switches closed FC1021.C-1 and/or FC1021.C-2.
- The wiring of the loading cover limit switches locked FC1025.C-1 and/or FC1025.C-2.

- Contact ECODAS technical support group.

ALARM 11:

Displayed message: ***PADDLE ASSEMBLY FAULT***

Possible cause of the alarm:

- Mechanical jam of the motor drive.
- The circuit-breaker of driver Q601 is triggered.
- The driver V601 is out of order.
- There is a mechanical blocking of the gear motor M601.
- The paddle motor drive M601 is not operational.

Results on the sterilization cycle:

- In between two sterilization cycles, the PLC will allow the start of a new cycle only if the problem is fixed.
- During the shredding stage the cycle continues.
- During the heating stage the cycle continues.
- During the standing stage the cycle continues.
- During the cooling stage the cycle continues.
- During the unloading stage the cycle continues.

Operator's instructions:

- Complete the cycle then inform the maintenance department.
- The displayed message can be deleted by pushing **ACKNOWLEDGE** button on HMI touch screen.
- The Flashing warning red light can be stopped by pressing the **FAULT RESET** button.

Conduite à suivre par le service maintenance:**Maintenance department guide:**

- If the paddle disconnect switch Q601 is in ON position, check the frequency inverter V601 and check the wiring of the motor drive. Otherwise, turn the disconnect switch Q601 ON. Do not repeat this operation more than three times.
- Contact ECODAS technical support group.

ALARM 12*:

Displayed message: ***REPLACING FILTER CARTRIDGE***

Possible cause of the alarm:

- The filter cartridge 402 has been used for 25 sterilization cycles.

Results on the sterilization cycle:

- No effect on the operation of the sterilizer.

Operator's instructions:

- Complete the cycle then inform the maintenance department.
- The displayed message can be deleted by pushing **ACKNOWLEDGE** button on HMI touch screen.

Maintenance department guide:

- Replace the filter cartridge 402 before the 25 Th sterilization cycle, or every year.
- Validate the replacement of the filter cartridge by pressing the **CHANGING FILTER WORK OUT** button below the displayed message.
- Contact ECODAS technical support group if necessary.

(* :filter is an option)

ALARM 14:

Displayed message: **TRAPS LIMIT SWITCH FAULT**

Possible cause of the alarm:

- The traps are not closed properly.
- The traps closing limit switch closed FC303.C is not positioned properly.
- The traps closing limit switch closed FC303.C is not operational.
- The wiring of the traps limit switch closed FC303.C is faulty.

Results on the sterilization cycle:

- During the loading stage the cycle continues.
- During the shredding stage the cycle continues.
- During the heating stage the cycle continues.
- During the standing stage the cycle continues.
- During the cooling stage the cycle continues.
- During the unloading stage, the closing cover belt unlocks and the cycle becomes idle.

Operator's instructions:

- Complete the cycle then inform the maintenance department.
- The displayed message can be deleted by pushing **ACKNOWLEDGE** button on HMI touch screen.
- The Flashing warning red light can be stopped by pressing the **FAULT RESET** button.

Maintenance department guide:

Check:

- The proper closing of the traps.
- The traps limit switch FC303.C located on top of the air cylinder is securely closed.
- The wiring of the traps limit switch closed FC303.C located on top of the air cylinder.

- Replace the limit switch if it is defective.

- Contact ECODAS technical support group.

ALARM 15:

Displayed message: ***SHREDDER OVERLOADING FAULT***

Possible cause of the alarm:

- There is a mechanical jam of the shredder because of a heavy load or a super hard object.

Results on the sterilization cycle:

- During the loading stage the cycle continues.
- During the shredding stage the cycle is idle.
- During the heating stage the cycle continues.
- During the standing stage the cycle continues.
- During the cooling stage the cycle continues.
- During the unloading stage the cycle continues.

Operator's instructions:

- Check visually through the lighting window, if he has not metal item that is too large.
- The displayed message can be deleted by pushing **ACKNOWLEDGE** button.
- Restart the shredding step by pression the **FAULT RESET** button.
- If objects that too large are present, stop the cycle and notify the maintenance department.

Maintenance department guide:

- Launch the **SAFETY** cycle (138°C during 30 minutes) and contact ECODAS technical support group.

ALARM 16:

Displayed message: **LOADING SEAL COVER FAULT**

Possible cause of the alarm:

- Dirty seal.
- Inflatable cover seal not operational.
- Insuffisant air pressure supply.
- The air pressure seal limit switch FC.1023.I is not operational.

Results on the sterilization cycle:

- In between two sterilization cycles, the PLC will allow the start of a new cycle only if the problem is fixed.
- During the shredding stage the cycle is idle for 10 minutes.
- During the heating stage the cycle is idle for 10 minutes.
- During the standing stage the cycle is idle for 10 minutes.
- During the cooling stage the cycle is idle for 10 minutes.
- During the unloading stage the cycle is idle for 10 minutes.
- After this time delay the appliance decompresses through the filter.

Note: All the valves close, and the air cylinders remain in their states prior to the fault condition.

Operator's instructions:

- Complete the cycle then inform the maintenance department.
- The displayed message can be deleted by pushing **ACKNOWLEDGE** button on HMI touch screen.
- The flashing warning red light can be stopped by pressing the **FAULT RESET** button.

Conduite à suivre par le service maintenance:

Check:

- Air compressor generator is ON.
- Inlet compressed air valve is open.
- Enough air pressure in the air supply.
- The proper operation of the air pressure contact of the seal limit switch FC1023.G located in the electrical panel.
- The wiring of the air pressure regulator.
- Clean the seal, replace it if necessary.

- Contact ECODAS technical support group.

ALARM 17:

Displayed message: ***MACHINE LOW LEVEL FAULT***

Possible cause of the alarm:

- The low level vessel probe N107 is dirty or plugged.
- The connection of the low level vessel probe N107 is faulty.
- The low level vessel probe N107 is not operational.

Results on the sterilization cycle:

- In between two sterilization cycles, the PLC will allow the start of a new cycle only if the problem is fixed.
- During the shredding stage the cycle continues.
- During the heating stage the cycle continues.
- During the standing stage the cycle continues.
- During the cooling stage the cycle continues.
- During the unloading stage the cycle is idle after the draining phase.

Operator's instructions:

- Complete the cycle then inform the maintenance department.
- The displayed message can be deleted by pushing **ACKNOWLEDGE** button on HMI touch screen.
- The Flashing warning red light can be stopped by pressing the **FAULT RESET** button.

Maintenance department guide:

Check:

- The proper operation of the low level vessel probe N107.
- The water-resistant of the ball of the low level vessel probe N107.
- The wiring between the low level vessel probe N107 and the machine box.
- Replace the level sensor N107 if it is defective.

- Contact ECODAS technical support group.

ALARM 18:

Displayed message: ***STEAM FAULT***

Possible cause of the alarm:

- Inlet steam disconnect valve closed.
- Insufficient steam pressure.
- Leakage through the seal cover.

Results on the sterilization cycle:

- In between two sterilization cycles, the PLC will allow the start of a new cycle only if the problem is fixed.
- During the shredding stage the cycle is idle for 10 minutes.
- During the heating stage the cycle is idle for 10 minutes.
- During the standing stage the cycle is idle for 10 minutes.
- During the cooling stage the cycle is idle for 10 minutes.
- During the unloading stage the cycle is idle for 10 minutes.
- After this time delay the appliance decompresses through the filter.

Operator's instructions:

- Complete the cycle then inform the maintenance department.
- The displayed message can be deleted by pushing **ACKNOWLEDGE** button on HMI touch screen.
- The Flashing warning red light can be stopped by pressing the **FAULT RESET** button.

Maintenance department guide:

Check:

- The defective seal must be replaced.
- The steam supply is ON.

- Contact ECODAS technical support group.

ALARM 19:

Displayed message: ***SEAL LEAKAGE FAULT***

Possible cause of the alarm:

- Leakage through the loading cover seal.
- Leakage through the unloading cover seal.

Results on the sterilization cycle:

- In between two sterilization cycles, the PLC will allow the start of a new cycle only if the problem is fixed.
- During the shredding stage the cycle continues.
- During the heating stage the cycle continues.
- During the standing stage the cycle continues.
- During the cooling stage the cycle continues.
- During the unloading stage the cycle continues.

Operator's instructions:

- Complete the cycle then inform the maintenance department.
- The displayed message can be deleted by pushing **ACKNOWLEDGE** button on HMI touch screen.
- The Flashing warning red light can be stopped by pressing the **FAULT RESET** button.

Maintenance department guide:

Check:

- Locate the leakage spot.
- The defective seal must be replaced.
- Clean the seal.

- Contact ECODAS technical support group.

ALARM 20:

Displayed message: ***SHREDDER LUBRICATION FAULT***

Possible cause of the alarm:

- No grease in lubricator pump M210.
- The grease pump disconnect switch Q210 is in OFF position.
- The wiring of the lubricator limit switch FC210 is faulty.
- The lubricator limit switch FC210 is not operational.
- Lubricator pump M210 is not operational.

Results on the sterilization cycle:

- No effect on the operation of the machine for five cycles. If the problem is not fixed beyond that the treatment cycle is locked on the heating stage.

Operator's instructions:

- Complete the cycle then inform the maintenance department.
- The displayed message can be deleted by pushing **ACKNOWLEDGE** button on HMI touch screen.

Maintenance department guide:

Check:

- The grease pump circuit-breaker Q210.
- The limit switch FC210 connection of grease pump.
- Replace the limit switch FC210 of grease distributor.

- Contact ECODAS technical support group if necessary.

ALARM 22*:

Displayed message: **VACUUM PUMP FAULT**

Possible cause of the alarm:

- The vacuum pump disconnect switch Q801 is OFF.
- Mechanical jam of the pump M801.
- The pump motor drive M801 is not operational.

Results on the sterilization cycle:

- In between two sterilization cycles, the PLC will allow the start of a new cycle only if the problem is fixed.
- During the shredding stage the cycle continues.
- During the heating stage the cycle continues.
- During the standing stage the cycle continues.
- During the cooling stage the cycle continues.
- During the unloading stage the cycle continues.

Operator's instructions:

- Complete the cycle then inform the maintenance department.
- The displayed message can be deleted by pushing **ACKNOWLEDGE** button on HMI touch screen.
- The Flashing warning red light can be stopped by pressing the **FAULT RESET** button.

Maintenance department guide:

- If the vacuum pump disconnect switch Q801 is in ON position, check the wiring of the motor drive. Do not repeat this operation more than three times.
- Contact ECODAS technical support group.

(* : vacuum pump is an option)

ALARM 23:

Displayed message: ***COOLING STAGE FAULT***

Possible cause of the alarm:

- Build up in piping system.
- Build up in the outlet cooling filter pump.

Results on the sterilization cycle:

- During the cooling stage the cycle continues.

Operator's instructions:

- Complete the cycle then inform the maintenance department.
- The displayed message can be deleted by pushing **ACKNOWLEDGE** button on HMI touch screen.
- The Flashing warning red light can be stopped by pressing the **FAULT RESET** button.

Maintenance department guide:

Check :

- If the decompression valve V181 is opened.
- Check the decompression piping until flash tank.
- Check the flash tank.

- Contact ECODAS technical support group if necessary.

ALARM 24*:

Displayed message: ***MOTOREDUCTOR LIFT FAULT***

Possible cause of the alarm:

- The circuit-breaker Q901 is triggered.
- There is a mechanical locking of lift.
- The driver V901 is out of order.
- The lift motor M901 is out of order.

Results on the sterilization cycle:

- During a stop between two sterilization cycles, the PLC will only authorize the launch of a new cycle if the problem is resolved.
- During the crushing stage, the cycle keeps on running.
- During the heating stage, the cycle keeps on running.
- During the standing stage, the cycle keeps on running.
- During the cooling stage, the cycle keeps on running.
- During the unloading stage, the cycle keeps on running.

Operator's instructions:

- Complete the cycle then inform the maintenance department.
- The displayed message can be deleted by pushing **ACKNOWLEDGE** button on Panel-View touch screen.
- The Flashing warning red light can be stopped by pressing the **FAULT RESET** button.

Maintenance department guide:

- If the cutout Q901 is not released, check the frequency inverter V901 and check the connection of the fault contact. Otherwise, rearm the cutout Q901, do not effectuate the operation more than 3 times.
- Contact ECODAS technical support group.

(* : if the machine is equipped with the option lift)

ALARM 25:

Displayed message: ***FLASH TANK TEMPERATURE PROBE FAULT***

Possible cause of the alarm:

- The temperature probe in the flash tank is out of order.
- The flash tank temperature probe connection is defective.

Results on the sterilization cycle:

- During the loading stage, the cycle continues.
- During the shredding stage, the cycle continues.
- During the heating stage, the cycle continues.
- During the standing stage, the cycle continues.
- During the cooling stage, the cycle continues.
- During the unloading stage, the cycle continues.

Operator's instructions:

- Complete the cycle then inform the maintenance department.
- The displayed message can be deleted by pushing **ACKNOWLEDGE** button on HMI touch screen.
- The flashing warning red light can be stopped by pressing the **FAULT RESET** button.

Maintenance department guide:

Check:

- The resistance at the end of the temperature probe wire must be around 100 Ohms.
- Check the wiring between the temperature probe and the electrical panel.
- Replace the defective probe.
- Contact ECODAS technical support group if necessary.

ALARM 26:

Displayed message: ***FLASH TANK COOLING FAULT***

Possible cause of the alarm:

- The temperature in the flash tank has reached the authorized maximum temperature.

Results on the sterilization cycle:

- During the loading stage, the cycle continues.
- During the shredding stage, the cycle is idle.
- During the heating stage, the cycle continues.
- During the standing stage, the cycle continues.
- During the cooling stage, the cycle continues.
- During the unloading stage, the cycle continues.

Operator's instructions:

- Inform the maintenance department.
- The displayed message can be deleted by pushing **ACKNOWLEDGE** button on HMI touch screen.
- The flashing warning red light can be stopped by pressing the **FAULT RESET** button.

Maintenance department guide:

Check :

- If solenoid valve EV1013 is opened.
- Check the water inlet piping.

ALARM 27:

Displayed message: ***MANUAL COMMAND***

Possible cause of the alarm:

- The machine is in manual mode.

Results on the sterilization cycle:

- During the loading stage, the cycle stops.
- During the shredding stage, the cycle stops.
- During the heating stage, the cycle stops.
- During the standing stage, the cycle stops.
- During the cooling stage, the cycle stops.
- During the unloading stage, the cycle stops.

Operator's instructions:

- Restarting can only be done by a person from the maintenance department who has the key for resetting the emergency stop or operating in manual mode.
- The displayed message can be deleted by pushing **ACKNOWLEDGE** button on HMI touch screen.

ALARM 28:

Displayed message: ***DRIVERS SAFETY UNLOCKING***

Possible cause of the alarm:

- The “Drivers safety unlocking” button is active.

Results on the sterilization cycle:

- During the loading stage, the cycle stops.
- During the shredding stage, the cycle stops.
- During the heating stage, the cycle stops.
- During the standing stage, the cycle stops.
- During the cooling stage, the cycle stops.
- During the unloading stage, the cycle stops.

Operator’s instructions:

- Only staff with level 2 user codes (at least) have access. Press the “Drivers safety unlocking” button again to make the alarm disappear.
- The displayed message can be deleted by pushing **ACKNOWLEDGE** button on HMI touch screen.

ALARM 32*:

Displayed message: ***BOILER FAULT***

Possible cause of the alarm:

- A default was detected when the boiler was switch on.

Results on the sterilization cycle:

- Stop of boiler heating.
- During the shredding, heating and standing stage, risk of alarms appearing related to heating.

Operator's instructions:

- Don't stop the current cycle and prevent the maintenance department.
- The displayed message can be deleted by pushing **ACKNOWLEDGE** button on HMI touch screen.
- The flashing warning red light can be stopped by pressing the **FAULT RESET** button.

Maintenance department guide:

Check :

- Check the boiler indicators.

(* : If boiler fault option)

ALARM 33*:

Displayed message: ***BOILER PRESSURE PROBE FAULT***

Possible cause of the alarm:

- The boiler pressure probe is out of order.
- The boiler pressure probe connection is defective.

Results on the sterilization cycle:

- Between two sterilization cycles, the PLC will allow the start of a new cycle only if the problem is fixed.
- During the shredding stage, the cycle continues.
- During the heating stage, the cycle continues.
- During the standing stage, the cycle continues.
- During the cooling stage, the cycle continues.
- During the unloading stage, the cycle continues

Operator's instructions:

- Complete the cycle then inform the maintenance department.
- The displayed message can be deleted by pushing **ACKNOWLEDGE** button on HMI touch screen.
- The flashing warning red light can be stopped by pressing the **FAULT RESET** button.

Maintenance department guide:

- Check the wiring between the pressure probe and the machine box.
- Change the defective probe.
- Contact ECODAS technical support group.

(* : If pressure probe option)

ALARM 35:

Displayed message: ***TERMINAL OPERATOR BATTERY FAULT***

- The battery of the operator console is low and has to be replaced.
(Refer to the Omron instructions manual)
- In case if the program logic is lost, it can be downloaded back to the memory card.
- Contact ECODAS technical support group.

ALARM 37:

Displayed message: ***PLC BATTERY FAULT***

- The battery of the PLC is low and has to be replaced.
(Refer to the Omron instructions manual)
- If the program is lost, it will still be possible to load with a memory card.
- Contact ECODAS technical support group.

ALARM 38:

Displayed message: ***POWER FAILURE DURING A TREATMENT CYCLE***

- The treatment cycle has been interrupted because of a power failure.
- Restore power and start the cycle where it was stopped.
- Contact ECODAS technical support group if necessary.

ALARM 40 :

Displayed message: ***UNLOADING COVER UNLOCKING DEFAULT***

Possible cause for the Alarm:

- The unloading cover is not unlocked properly.
- The unloading cover limit switch unlocked FC1042.O is not positioned properly/not operational.
- The distributor EV1021.O is not operational.

Impact on the sterilization cycle:

- During the loading stage the cycle is idle.

Operator's instructions:

- Complete the cycle then inform the maintenance department.
- The displayed message can be deleted by pushing **ACKNOWLEDGE** button on Panel-View touch screen.
- The Flashing warning red light can be stopped by pressing the **FAULT RESET** button.

Maintenance department guide:

Check:

- The proper unlocking of the loading belt.
- The limit switch position loading belt unlocking FC1042.O.
- The wiring of the unlocking belt limit switch opened FC1021.O.
- The pneumatic distributor functionment EV1042.

- Contact ECODAS technical support group if necessary.

ALARM 41 :

Displayed message: ***CHAIN SECURITY DEFAULT N107***

Possible cause for the Alarm:

- The low level vessel probe N107 is dirty.

Impact on the sterilization cycle:

- During the loading stage the cycle is idle.
- During the draining stage the cycle is idle.
- During the unloading stage the cycle is idle.

Operator's instructions:

- Complete the cycle then inform the maintenance department.
- The displayed message can be deleted by pushing **ACKNOWLEDGE** button on Panel-View touch screen.
- The Flashing warning red light can be stopped by pressing the **FAULT RESET** button.

Maintenance department guide:

Check:

- The probe contact N107.
- The wiring between the low level vessel probe N107 and the machine box.
- Replace the probe N107 if it is defective.

- Contact ECODAS technical support group.

ALARM 42 :

Displayed message: ***CHAIN SECURITY DEFAULT P50***

Possible cause for the Alarm:

- The pressure is >50mbars..
- The pressure switch P50 is not operational.

Impact on the sterilisation cycle:

- During the loading stage the cycle is idle.
- During the unloading stage the cycle is idle.

Operator's instructions:

- Complete the cycle then inform the maintenance department.
- The displayed message can be deleted by pushing **ACKNOWLEDGE** button on Panel-View touch screen.
- The Flashing warning red light can be stopped by pressing the **FAULT RESET** button.

Maintenance department guide:

Check:

- The pressure in the tank (<50mbars).
- The pressure switch connection and parameter P50.

- Contact ECODAS technical support group.

ALARM 43 :

Displayed message: ***CHAIN SECURITY DEFAULT V1018***

Possible cause for the Alarm:

- The valve V1018 is closed.
- The exhaust air valve limit switch opened FC1018 is not positioned properly/not operational.
- The pneumatic distributor EV1018 is defective.

Impact on the sterilization cycle:

- During the loading stage the cycle is idle.
- During the unloading stage the cycle is idle.

Operator's instructions:

- Complete the cycle then inform the maintenance department.
- The displayed message can be deleted by pushing **ACKNOWLEDGE** button on Panel-View touch screen.
- The Flashing warning red light can be stopped by pressing the **FAULT RESET** button.

Maintenance department guide:

Check:

- The proper opening of the valve V1018.
- The limit switch position exhaust air valve opened FC1018.
- The wiring of the exhaust air valve limit switch opened FC1018.
- The pneumatic distributor functionment EV1018.

- Contact ECODAS technical support group.

ALARM 44 :

Displayed message: ***OPENING LOADING BELT DEFAULT***

Possible cause for the Alarm:

- The loading belt is not opened properly.
- The loading belt limit switch opened FC1021.O is not positioned properly/not operational.
- The pneumatic distributor EV1021.O is not operational.

Impact on the sterilization cycle:

- During the loading stage the cycle is idle.

Operator's instructions:

- Complete the cycle then inform the maintenance department.
- The displayed message can be deleted by pushing **ACKNOWLEDGE** button on Panel-View touch screen.
- The Flashing warning red light can be stopped by pressing the **FAULT RESET** button.

Maintenance department guide:

Check:

- The proper opening for the loading belt.
 - The limit switch position loading belt opened FC1021.O.
 - The wiring of the loading belt limit switch opened FC1021.O.
 - The pneumatic distributor functionment EV1021.
-
- Contact ECODAS technical support group.

ALARM 45 :

Displayed message: ***LIFT USE AUTHORIZATION DEFAULT***

Possible cause for the Alarm:

- The loading cover is not opened properly.
- The loading cover limit switch opened FC1026.O is not positioned properly/not operational.
- The loading belt limit switch opened FC1021.O is not positioned properly/not operational.

Impact on the sterilization cycle:

- During the loading stage the cycle is idle.

Operator's instructions:

- Complete the cycle then inform the maintenance department.
- The displayed message can be deleted by pushing **ACKNOWLEDGE** button on Panel-View touch screen.
- The Flashing warning red light can be stopped by pressing the **FAULT RESET** button.

Maintenance department guide:

Check:

- The proper opening of the loading cover.
- The limit switch position loading cover opened FC1026.O.
- The limit switch position loading belt opened FC1021.O.
- The wiring of the loading limit switches opened FC1021.O and FC1026.O

- Contact ECODAS technical support group.

4.2 PNEUMATIC ACTUATORS FAULTS

ACTUATORS	PROBABLE CAUSE	CORRECTIVE ACTION
Valves Air cylinder	Actuator jam	Check/Replace actuator
	Lack of air	Check air supply
	Faulty pneumatic hose	Check/Replace hosing
	High solenoid valve out of order	Check/Replace
	Wiring fault between control components (relays, limit switches, PLC Input/output module...) and High solenoid valve	Check wiring
	Faulty contact, relays, limit switches, PLC Input/output module which control the solenoid valve	Check/Replace
Seals	Seal leakage	Check/Replace seal
	Lack of air	check air supply
	Check valve not operational	Check/Replace
	Faulty pneumatic hose	Check/Replace hosing
	High solenoid valve out of order	Check/Replace
	Wiring fault between control components (relays, limit switches, PLC Input/output module...) and High solenoid valve	Check wiring
	Faulty contact, relays, limit switches, output module digital board which control the solenoid valve	Check/Replace

Attention: It is mandatory to contact ECODAS technical support group before proceeding with any interventions on the machine.

4.3 ELECTRICAL PROTECTIONS OF THE MACHINE

ITEM No	DESIGNATION	REFERENCE
Q1	Main power disconnect switch	
F202	Fuse of shredder 202. (T300 model)	32A aM
F202	Fuse of shredder 202.(T700-T1000-T2000 model)	40A aM
F203	Fuse shredder 203. (T2000 model)	40A aM
Q601	Paddle disconnect switch 601.	
Q901	Lift motor drive disconnect switch (optional)	
Q1022	Lighting disconnect switch 24 Volts DC (T300/T700/T1000/T2000)	Parameter:4A
Q20	Disjoncteur du primaire de l'alimentation redressée filtrée T2 24 Volts continu.	Parameter: 3A
Q21	Filtered air supply disconnect switch T2 24 Volts direct current	Parameter:4A
Q22	PLC and operator's console disconnect switch 24 Volts DC	Parameter:4A
Q210	Actuator disconnect switch 24 Volts DC	Parameter:4A
Q30	The oil pump disconnect switch 24 Volts DC	Parameter:6A
Q31	The disconnect switch of the transformer T1 380 / 220 Volts 50HZ	Parameter:4A
Q32	Power supply disconnect switch 220 Volts 50HZ	Parameter:1A

4.4 ALARM AND LIGHTS

TYPE SIGNALISATION	SIGNIFICATION	CONSEQUENCE
Green indicator light beacon ON	Cycle in progress	
Green indicator light beacon OFF	Cycle stopped	
Orange indicator light beacon flashing Orange button of panel door flashing	Operator call	The operator must keep the button press to continue the cycle. The operator must keep the button press to activate the opening / closing of covers and traps
Red indicator light beacon flashing	Minor operating cycle error (alarm for filter changing,...).	The operator must solve the default.
Red indicator light beacon flashing + siren	Major operating cycle error (alarm, ...).	Require the maintenance department intervention

5. RECOVERY – PRODUCT DISPOSAL

As part of the effectiveness of our environmental approach, we want to limit the environmental damage that can be caused by the disposal of the product at the end of its life.

That's why we recommend:

Electrical elements: All the electrical elements installed on the machine or its accessories must be returned to us for destruction from the original supplier.

Stainless steel components: As these elements are entirely recoverable, we invite you to approach a company specialized in the recovery of metals for recycling and recovery. The STAINLESS STEEL components elements include: vessel, covers, feet, paddle (except shaft) and shredder body.

Components made of SPECIAL STEELS: These elements being entirely recoverable, we invite you to approach a company specialized in the recovery of metals for recycling and recovery. The SPECIAL STEELS components include: lift, shredder (except body), couplings (shredder - paddle).



6. QUICK START

6.1 BOILER START

- 1) Check the pressure on manometer (*rep 9*). If it is superior or equal at 0 bar, skip directly at step 3.

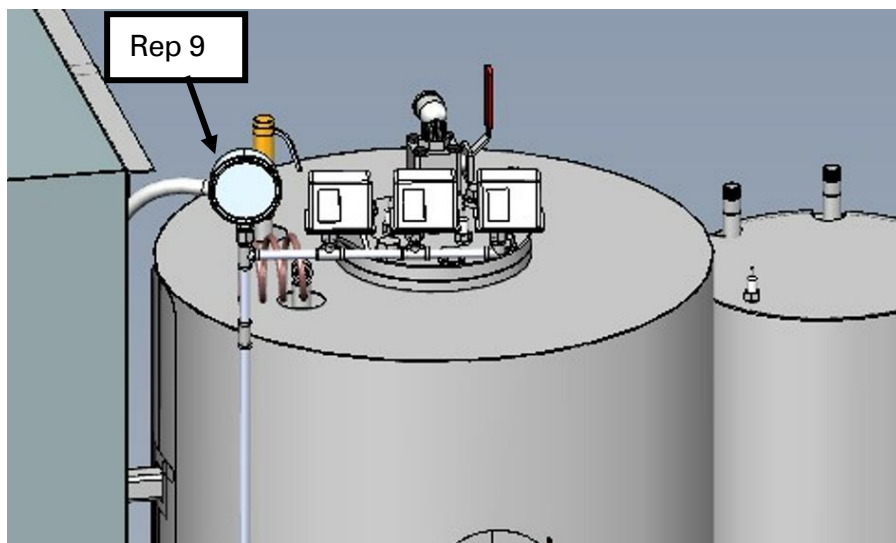

- 2) Otherwise, open the purge valve at the level of pressure switch ramp (*rep 14*) for reduce to atmospheric pressure.

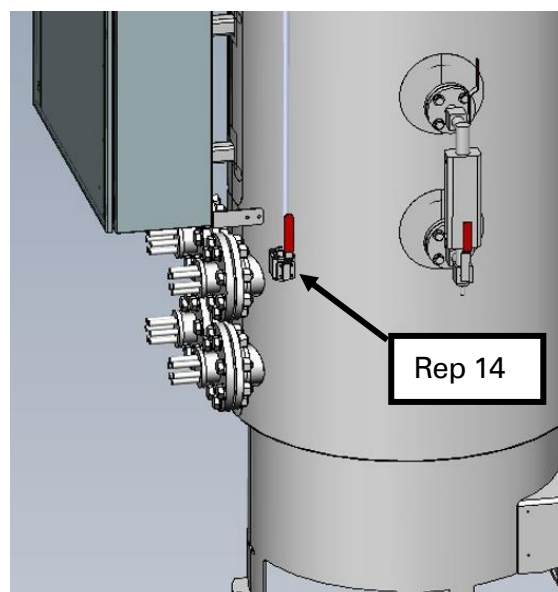



Warning : this valve must not be open if the pressure in the boiler is greater than 1 bar, under penalty of damaging the pressure switches

- 3) Open the isolation valve between the pump and the boiler (*rep 19*).

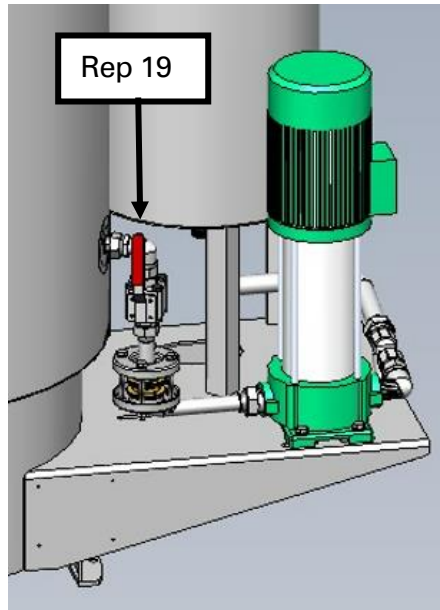

- 4) Power up the panel by turning the disconnect.

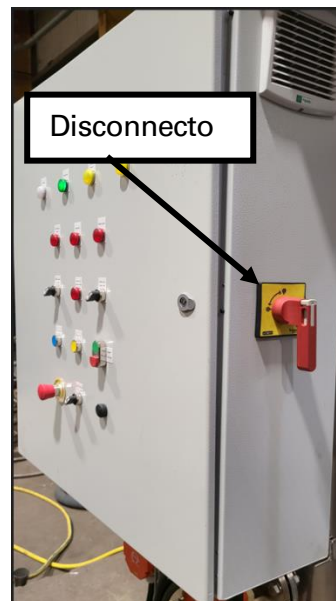

- 5) Push the blue button « Fault reset ».

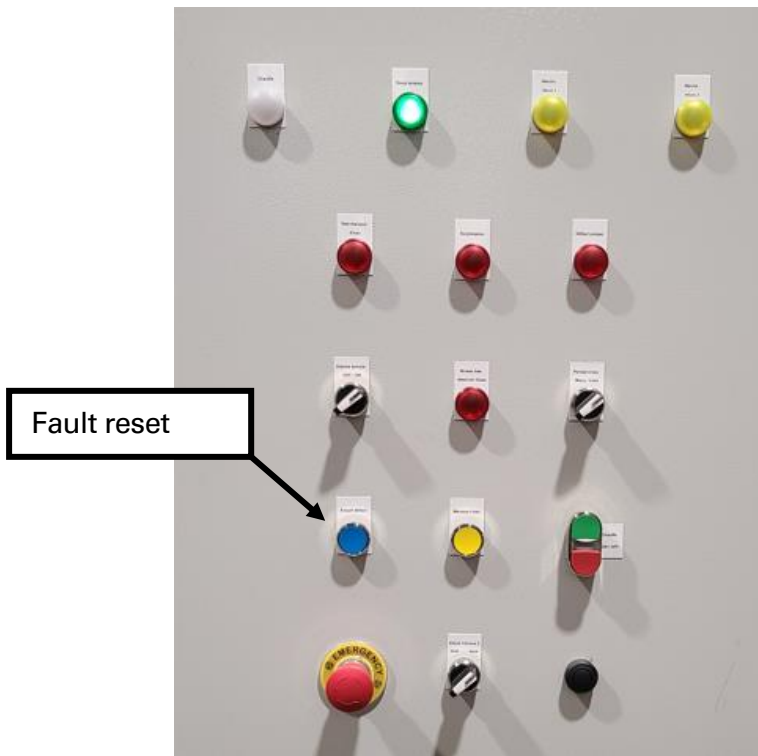

- 6) Make sure through the level indicator (level probes (rep 15, 16, 17) and level visual (rep 18)) that the water filling in the boiler is correct.

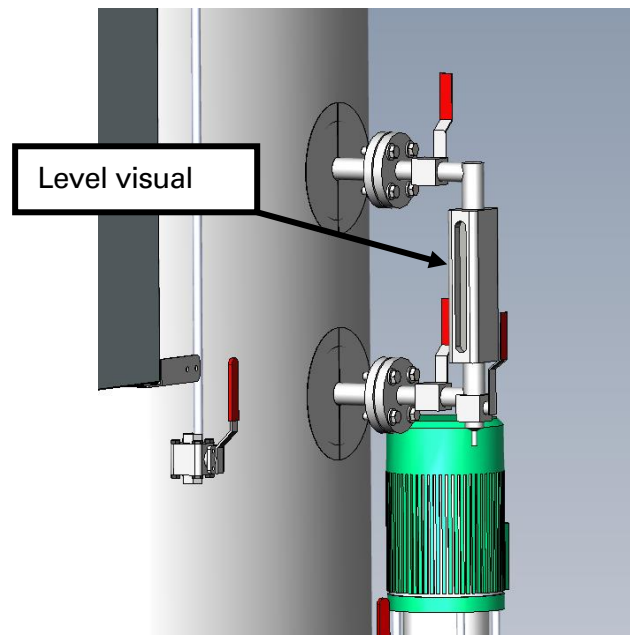

→ 7) Push the green button « ON » (Heater).

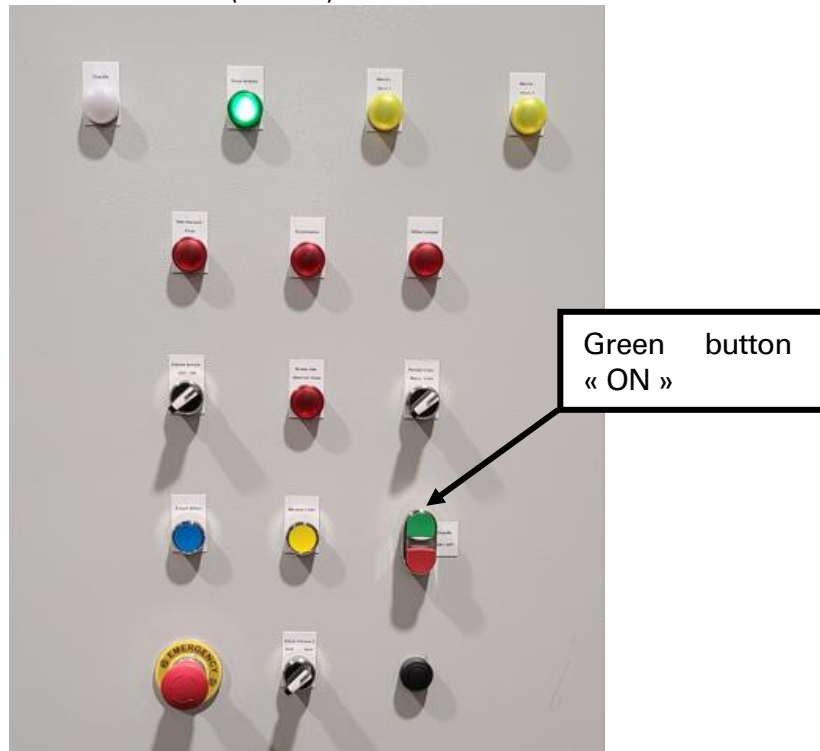

8) Open the isolation valve of steam outlet to the machine (rep 20).

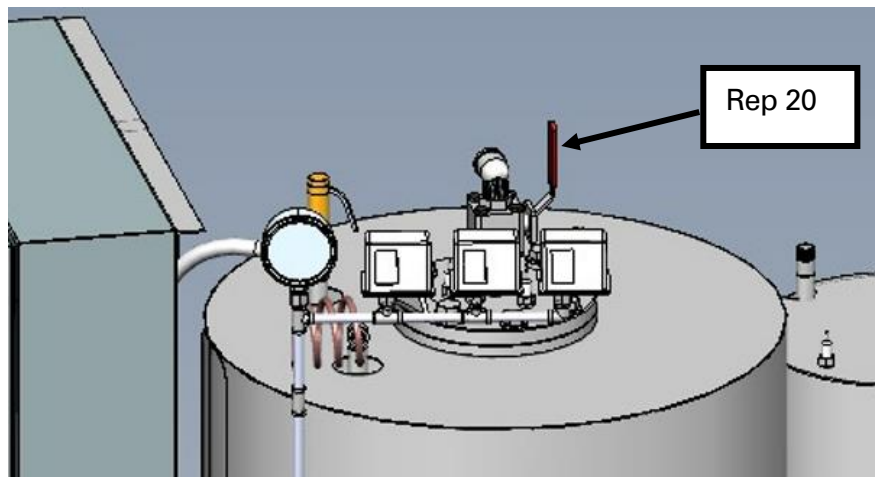

6.2 COMPRESSOR START

- 1) Push the green button « ON ».

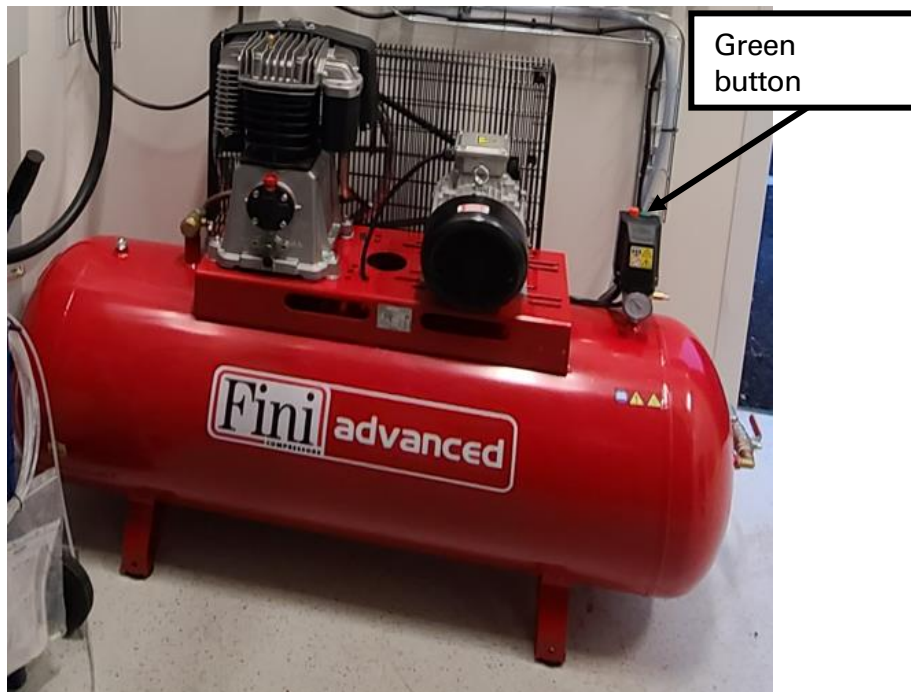

- 2) Open the air outlet valve of compressor.

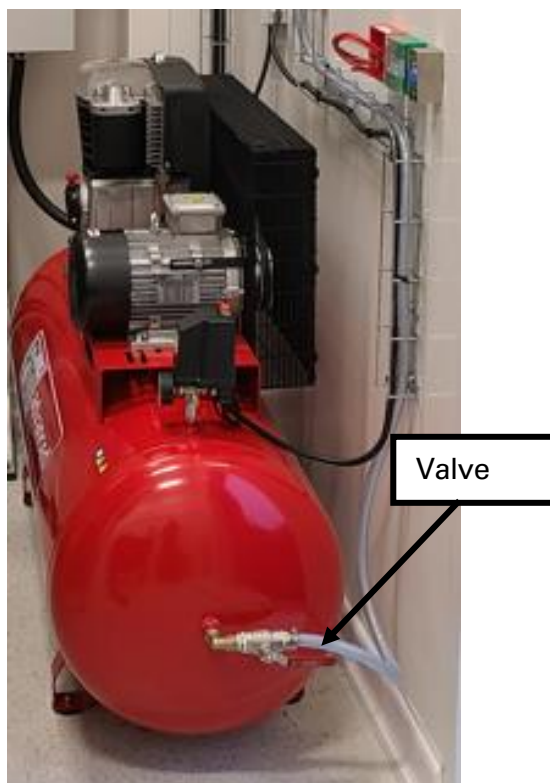

6.3 MACHINE START

- 1) Power up the panel by turning the disconnecter.



- 2) Push the black button « Fault reset ».

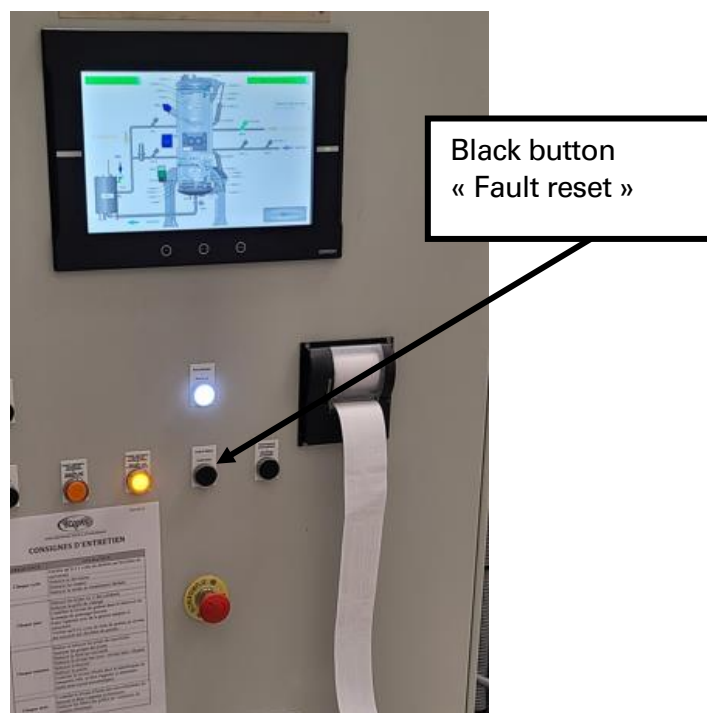

- 3) Push the black button « Rearming pneumatic ».

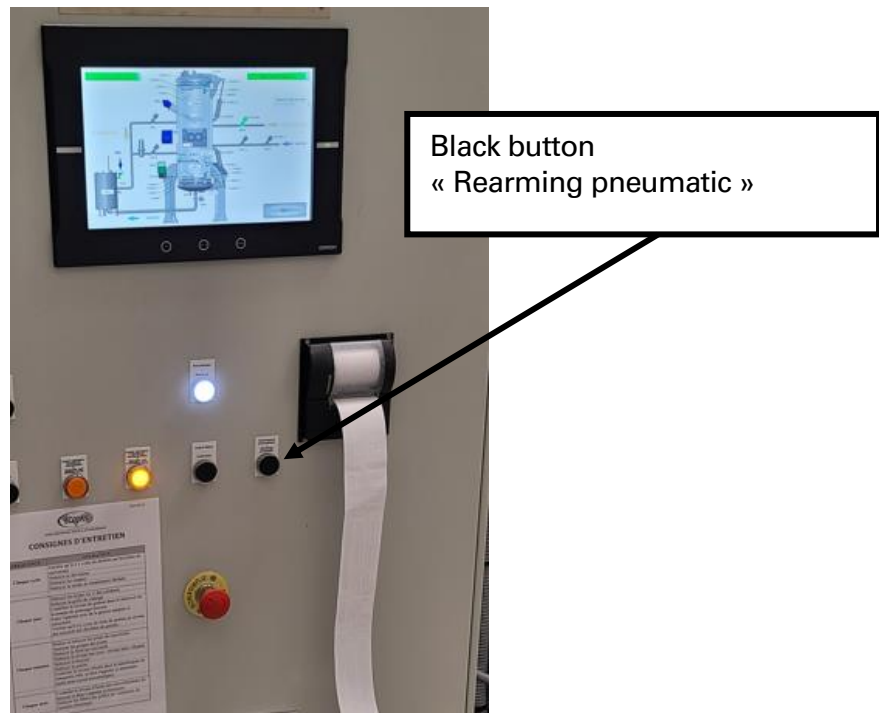

- 3) Start a cycle with the command screen (see paragraph).