



Referans (Reference)	Ölçüler (Dimensions)
La	490 mm
Lb	378 mm
Lc	138 mm
Ld	250 mm
A	(13+2.85*N) mm
V	1,7 to 33 lt

N:Plaka Sayısı (Number Of Plates)

Ağırlık (Weight)	(N*0.37+6.5) kg
Test (Test)	Su (Water)
Dizayn Basıncı (Design Pressure)	3.0 MPa
Test Basıncı (Test Pressure)	5.2 MPa

Maksimum Plaka Sayısı (Max. Plate Number) 150

Akış Plakaları (Flow Plates) 1.4404 / EN10088-2

Destek Plakaları (Cover Plates) 1.4301 / EN10088-2

Bağlantı Ağzı (Connection Port) S30408 / GB/T14976

Lehim (Solder) %99,9 Bakır (Copper)

Designed By İsmail Mert Genç 25.07.18 Rev00

Approved By Gökhan İncirli 25.07.18 Rev00

Revision By Cihan Güler 16.01.24 Rev01

Approved By Gökhan İncirli 16.01.24 Rev01

Dimensions without tolerance ISO 2768-m ISO projeksiyon Operating Temperature -196 °C/200 °C

Part Name: MB-10

EKİN ENDÜSTRİYEL Isıtma - Soğutma San. Tic. A.Ş.

A3 SHEET 1/1

SCALE 1:50

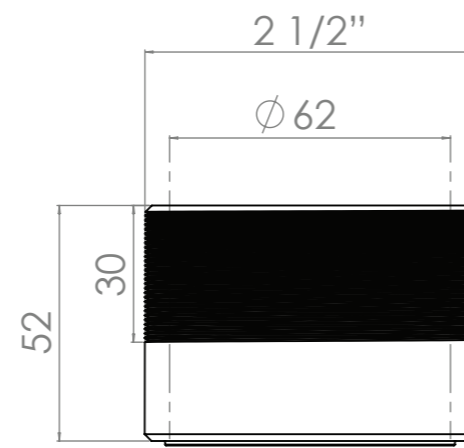
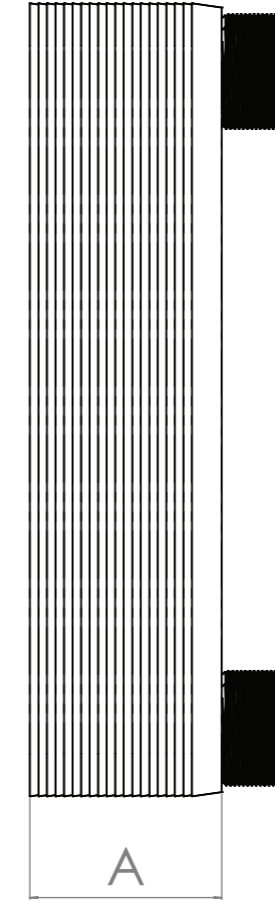
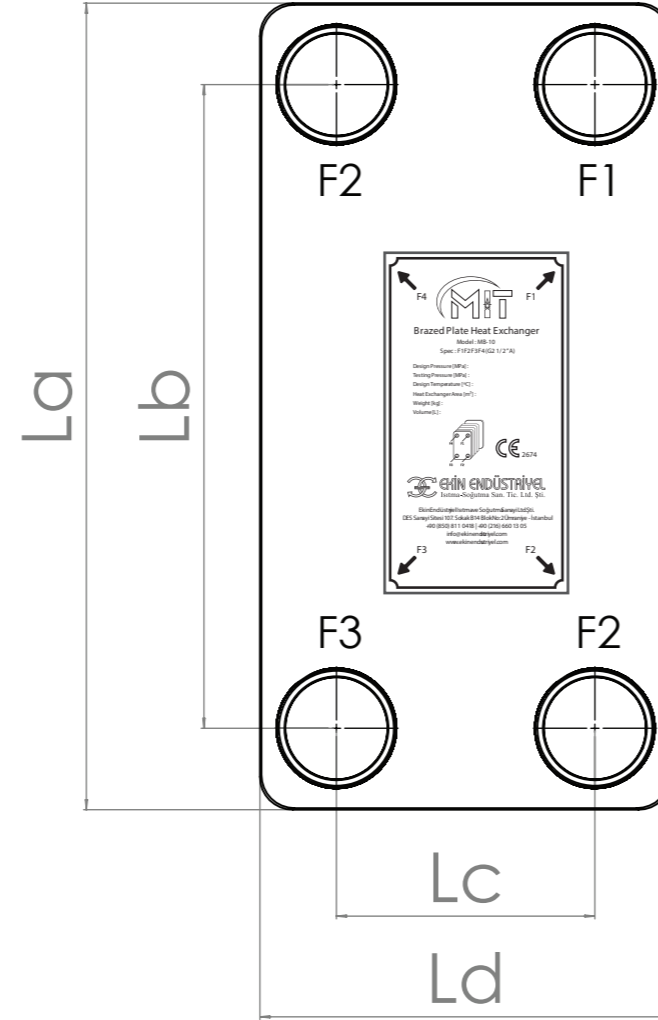

F1 F2 F3 F4
ISO228/1-R 2 1/2

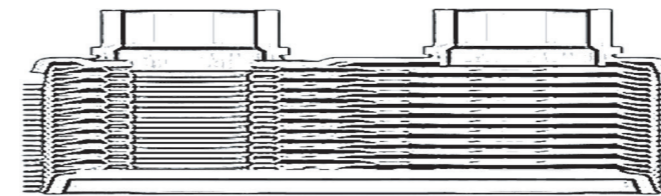

Lehimli Isı Eşanjörü / Brazed Plate Heat Exchanger	
Model Type	
Seri Numarası Serial Number	
Spesifikasyon Spec	
Dizayn/Test Basıncı (MPa) Design/Test Pressure	
Üretim Tarihi (aa.yy) Production Date (mm.yy)	
Dizayn Sıcaklığı (°C) Design Temperature	
Isı Transfer Yüzey Alanı (m²) Heat Trans. Surface Area	
Ağırlık (kg) Weight	
Hacim (L) Volume	
Flow F1 → F2 F3 → F4	
CE ISO EAC	
EKİN ENDÜSTRİYEL Isıtma - Soğutma San. Tic. A.Ş.	
Dudullu Organize Sanayi Bölgesi Des Sanayi Sitesi 107 Sk. B14 Blok No: 2 Ümraniye - İstanbul / Türkiye	
Telefon/Phone: +90 (216) 232 24 12 / 444 35 46	
info@ekinendustriyel.com	
www.ekinendustriyel.com	

*Ekin Endüstriyel önceden haber vermeden renk, ekipman aksesuarlar ve resimler üzerinde değişiklik yapma hakkını saklı tutar.
*Ekin Industrial reserves the right to make changes to models, colors, equipment, accessories and pictures without prior notice.