

L=760 1buc
L=620 1buc

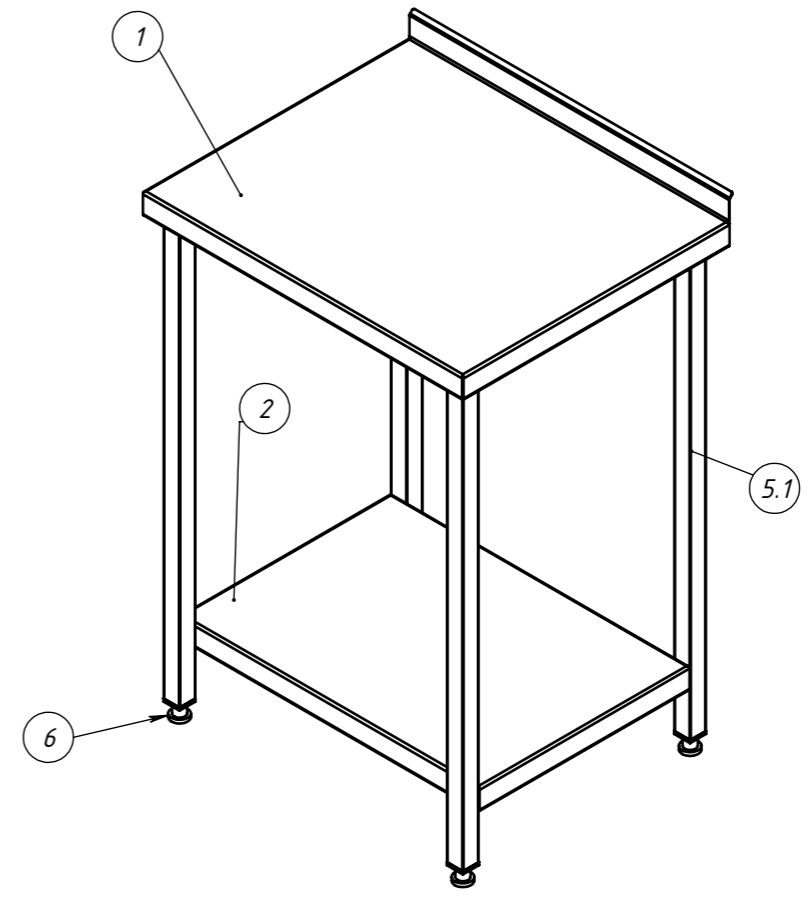
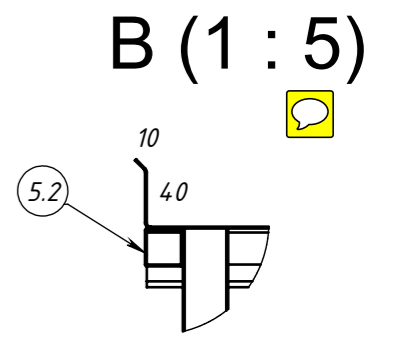

ITEM NO.	PART NUMBER	DESCRIPTION	ДЛИНА	QTU.
1	Blat 600x500	S1.2		1
2	polita 560x455	S1.0		1
3	Ranfort 520			1
4	Ranfort 560			1
5	carcas masa 700x500x850			1
5.1		Teava profilata 30 X 30 X 1,2	820	4
5.2		Teava profilata 25 X 25 X 1,2	597	1
6	picior	Reglabil		4

No	
Client	-
Inginer	Pleșivțev Artiom
Termen ex.	...2024

Masa 600x500x850 cu 1 polita

