

# Expert Vibro



## VIBRATION MEASUREMENT

Analysing. Monitoring. Intuitive configuration.



# Expert Vibro – MORE FLEXIBILITY

Expert Vibro is the device of choice for measuring a broad range of vibration types. Following on from the success of the 8 and 16 vibration input models, we are now pleased to offer you models with 4 and 12 channels thereby responding to the needs of many customers for even more flexibility. You can now implement precisely the application you require without any channel overhead.

Expert Vibro makes vibration measurement intelligible. State-of-the-art processor technology enables 4, 8, 12 or 16 synchronous measuring channels with sampling rates of up to 50 kHz per channel, for the smallest of spaces and tailored to your requirements. 24 bit A/D converters guarantee high-level precision.

You have the flexibility to switch between measuring voltages, currents, IEPE or shaft vibration sensors. Integrated comparators and digital inputs allow for flexible triggering. Measurement data is monitored online and, in the event of limit value violations, digital outputs can be switched within msec.

## Intelligible configuration

Measuring vibrations using Expert Vibro is also possible for inexperienced users. Intuitive configuration ensures quick familiarisation and operation of the system. All relevant characteristic values are determined from time signals and spectra. Spectra are calculated online and stored autonomously together with time signals and characteristic values. Versatile software channels make the Expert Vibro suitable for in-depth analysis and monitoring requirements. A touch screen on the Expert Vibro provides a clear view of important configuration data and measurement data.

Inputs / Outputs	Type 4	Type 8	Type 12	Type 16
Analog inputs (mV, mA)	4	8	12	16
Analog outputs (mV, mA)	4	4	4	4
Digital / frequency inputs	4	4	4	4
Digital outputs	8	8	8	8



# EVERYTHING IN **ONE SYSTEM**

## Monitoring and online analysis

- Fast limit-value monitoring of time signals
- Monitoring of characteristic values
- Online calculation of measured values
- Spectrum – online – up to 12.800 lines (FFT)
- Diverse characteristic values (phase, frequency and amplitude values)
- Accounting and statistics function
- Integration functions (two-stage)

# Expert Vibro – THE MEASUREMENT **SPECIALIST**

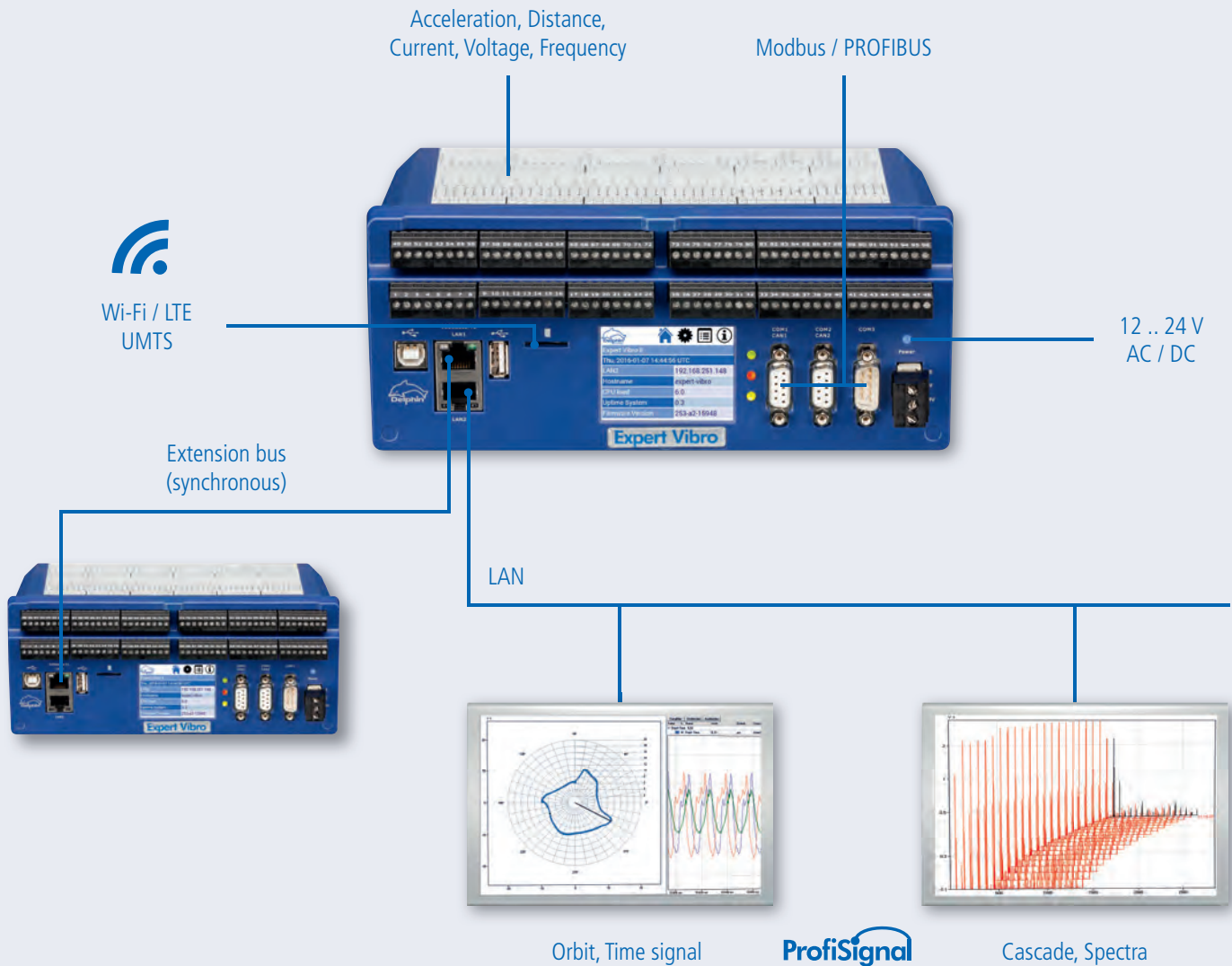



# UNIVERSAL. COMPACT. **VERSATILE.**

## Fully equipped – compact design

- 4 / 8 / 12 / 16 vibration inputs, individually triggerable
- 4 independent trigger groups (e.g. gear monitoring)
- 50 kHz sampling rate per channel ( $\Sigma$  to 800 kHz) – internal, external data storage possible
- Up to 14 GB data storage
- 4 digital inputs for frequency measurement up to 1 MHz
- 8 digital outputs
- 4 analog outputs for monitoring tasks
- Convenient DIN rail-mounting
- Graphics-capable display for on-site viewing

## Versatile applications

- Shaft vibration monitoring and analysis
- Machine and housing vibrations
- Roller bearing monitoring and bearing damage diagnostics
- Spindle monitoring and balancing
- Combustion chamber vibration monitoring
- Drive unit vibration analysis
- Air gap monitoring
- Mobile vibration measurement

## Universal sensor connection

- Software-switchable analog inputs
  - Shaft vibration / distance sensors
  - Acceleration sensors
  - Vibration velocity sensors
  - mV / mA signals (pressure etc.)
- Switchable IEPE power supply
- Integrated comparators for KeyPhasor® sensors
- Measuring range up to  $\pm 25$  V
- Plug-in screw terminals

## Diverse local and decentralized interfaces

- Interfaces to PCs
  - LAN interface
  - USB host for read-out of data memory
- Interfaces to fieldbuses
  - Modbus TCP
  - 2 x PROFIBUS DPV1 slave (redundant)
  - 3 x serial interfaces (Modbus RTU)
  - 2 x CAN interface
  - Optional OPC UA
- Remote monitoring
  - WLAN optional, GSM / UMTS / LTE optional

## Instant viewing of measurement data

ProfiSignal provides you with comprehensive measurement software. In combination with the Vibro option, ProfiSignal can be adapted precisely to your vibration measurement needs.

When configuring channels and before visualising and analysing measurement data with ProfiSignal, you can pre-process your signals according to your specific needs. A multitude of filter options are available for this purpose. A Bode plot enables you to instantly view the effects of your filter configuration.

After configuration, you can visualise and analyse measurement data using ProfiSignal, without any additional programming effort.





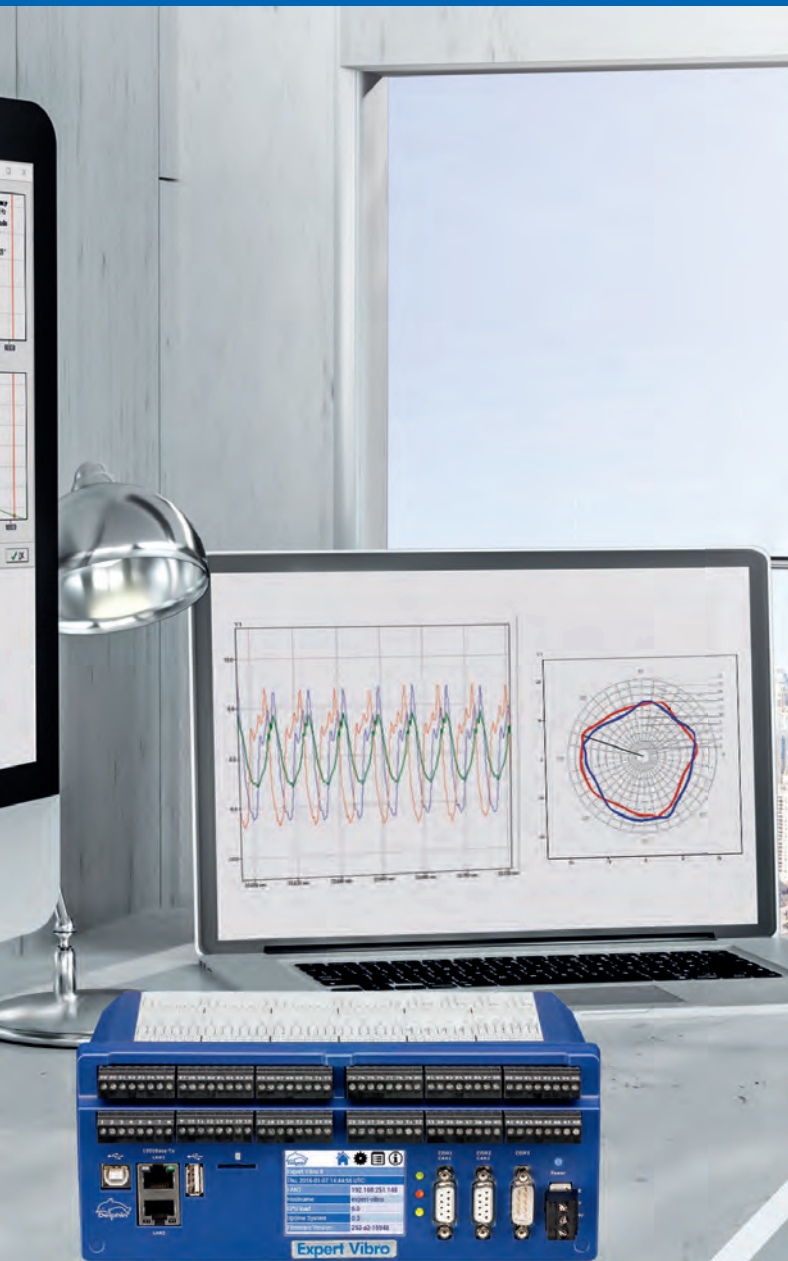

## Diagrams of option Vibro

- **Time signal diagram:**  
Visualise and analyse measurement data for a time period.
- **Orbit diagram:**  
View kinetic shaft paths including maximum deflection  $s_{max}$  and the angular position / phase for constant-speed machine operation.
- **Shaft centerline diagram:**  
View shaft centerline displacement as a function of speed during system start-up and shutdown.
- **Polar diagram:**  
Displays vibration vectors including amplitude and phase information.





# Different portrayals of spectra

In addition to a basic spectrum portrayal based on FFT analysis, you also get the following visualisation options:

## Envelope spectrum:

Provides information on current machine condition at early stages of emerging damage and aids filtering of condition-relevant frequencies.

## Cascade spectrum:

Enables the analysis of system behaviour during start-up and shutdown.

## Order analysis:

Normalises and displays frequencies according to the order of harmonic oscillations.

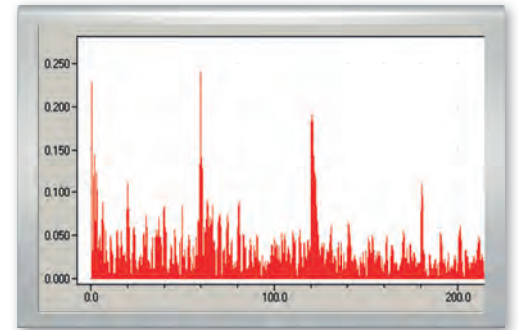

## Spectrogram:

Portrays a spectrum's temporal progression. The colour display facilitates quantitative evaluation and enables simple tracking of changes in frequency or amplitude.

## Bode plot:

Used to visualise the frequency response of your vibrating system during start-up and shutdown. This enables you to determine amplitude-phase characteristics.

# VIBRATION MONITORING AND

As a plant operator, you want high levels of availability and efficiency. Operating conditions need to be optimised and downtimes prevented while service and maintenance intervals need to be performed according to machine status or maintenance schedule.

Vibration monitoring and online analysis are therefore indispensable for your plant. Modern technology combined with a wide range of interfaces make this system not only applicable to new but also existing infrastructures.



# ONLINE-ANALYSIS

## Rotating plant. Machines. Components.

A practical example demonstrates how Expert Vibro devices are being used in hydroelectric power plants in dams, reservoirs and rivers.

Vibrations on Kaplan and Francis turbines are being monitored using Expert Vibro devices that then transmit characteristic values via redundant PROFIBUS interfaces to control systems. With an Expert Vibro device, up to 16 vibration sensors can be synchronously measured, analysed and monitored. Static shaft positioning and dynamic shaft vibrations of journal-bearing shafts can be determined with reference to bearing casings. Radial shaft positioning and rotational speeds are also acquired via a reference mark (KeyPhasor®) on the shaft. Phase information can be computed from the shaft position. From the measured time signal, the Expert Vibro device can directly compute a frequency / amplitude / phase spectrum as well as characteristic values such as  $s_{max}$  or peak-peak. The data can then be independently recorded or transmitted via Ethernet or PROFIBUS-DP to DCS systems or PCs.

Using ProfiSignal's Vibro software option, measurement data can be portrayed and evaluated in orbit, polar, bode, shaft centerline and FFT diagrams or spectrograms.

# SERVICE LIFE TEST STAND

## Securing competitiveness

**Service life testing is used to test products for long-term operation under realistic conditions and to certify service lives. It aids in the development of your products and thus directly contributes to securing your competitiveness.**

The special benefits you gain include simultaneous acquisition and monitoring of all relevant vibration and process data for the product under test, as well as highly dependable and available measurement data.





**A practical example demonstrates how one of the world's leading manufacturers of ball, roller and journal bearings uses our systems for service life test stand.**

For numerous service life testing systems, Expert Vibro devices are being used in combination with Profi Message slaves and the ProfiSignal Klicks software as instrumentation and control technology.

All vibration data is securely recorded together with process data such as temperatures, pressures, flow rates, speeds, etc. and monitored independently by the system. Various characteristic values and FFT spectra are portrayed online during the test process, analysed instantly and forwarded to a centralised SQL database. Stand-alone operation by the Expert Vibro, with its internal control and regulating functions, guarantees independent operation of each individual test stand. A frequency inverter and other peripherals are also controlled directly by the Expert Vibro device.

The ProfiSignal Klicks software was used to create the test procedure. All measurement data and test sample statuses remain clearly visible to the operator via a range of diagrams. A central database, storing all relevant test sample data, guarantees full traceability for each individually tested bearing. Testing can then be performed very flexibly and for example, paused and continued without any problem.



# SPINDLE TEST STAND

**A spindle test stand is used to check spindle-driven machine tools in production for unacceptable levels of vibration and imbalance.**

This is vital in the production of components requiring a very high level of dimensional precision. Unacceptably high vibrations and imbalances in spindle systems also mean significantly higher loads on bearings and thus lead to higher levels of wear and machine downtimes. A spindle test stand therefore helps to ensure high standards of quality for manufactured goods and increases levels of machine availability.





## Identifying loads and imbalances and **raising quality**

**A practical example demonstrates how a worldwide leading manufacturer of common-rail injectors and jets uses our systems in production.**

By using Expert Vibro devices, vibrations and speeds as well as spindle and bearing temperatures are constantly recorded and monitored during production. This gives the customer a condition monitoring system for machine tools.

All data is monitored using internal limit values. Subsequent spindle balancing is based on determining phase angles and associated imbalances which are calculated online using the ProfiSignal software and the Expert Vibro device's internal analysis-channels.

If a limit value is exceeded during production, the operator is immediately prompted to balance the spindle. The balancing process is then carried out using the measurement data and instantly evaluated using the ProfiSignal application. In this way, the customer's requirements for high quality manufactured products and machine availability are being fulfilled.



# Expert Vibro **MOBILE**

## Highlights of the vibration measuring case

- Mobile with high-resolution data acquisition
- Synchronous measurement of analog signals
- Universal vibration inputs with sampling rates up to 50kHz / channel
- Calculation of characteristic values directly in the device
- Measurement of process and vibration values in one system
- System tailored to your measurement needs

## Diverse applications

- Measuring vibrations and process values
- Mobile acceptance control
- Monitoring pressure vibrations
- Measuring and analysing machine vibrations
- Shaft vibration analysis and diagnosis
- Measuring electrical vibration variables with combined power measurements
- Mobile bearing monitoring





# SECURE MONITORING

## Compact design for mobile use

The vibration measuring case from Delphin has been specially developed for measurement requirements in the field of vibration technology. Its compact design makes it highly suited to mobile use while providing all the functions needed for analysis as well as all those expected in a stationary measurement system.

Depending on the model being used, mechanical and electrical vibration analyses can be carried out directly. A PC connection is unnecessary for measuring because the integrated data logger operates fully independently and calculates FFTs, characteristic values and RMS values directly within the device. The internal device memory securely stores your measurement data.

The measuring case can be individually adapted to your measurement needs and is therefore a flexible and powerful companion whether for run-out analysis, acceptance control, error and fault diagnostics or mobile vibration monitoring. High-resolution measurement data and fully synchronous analog inputs provide meaningful measurement information. Internal signal conditioning simplifies working procedures and saves on the need for expensive measurement transducers or any other additional equipment. Galvanic isolation and differential inputs prevent interference from process signals or earth loops.

The user-friendly ProfiSignal software and option Vibro provide you with tools tailored to vibration analysis. You will appreciate the easy operation and diagram types especially designed for vibration measurement. Measurement and analysis is the priority rather than time-consuming training in a new measuring technique.

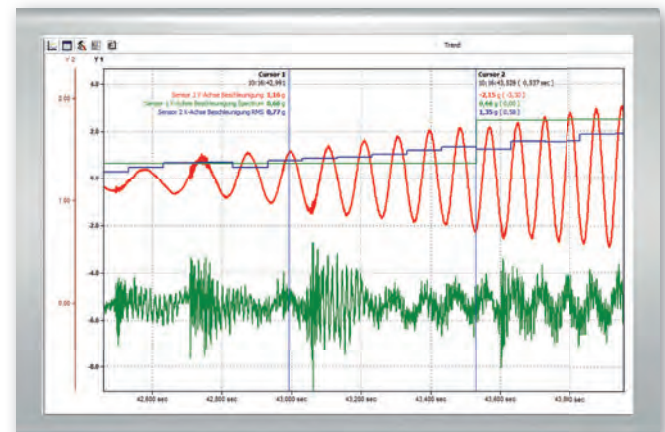

# Expert Vibro – TECHNICAL SPECIFICATIONS

<b>Inputs / Outputs</b>	
Analog inputs	4, 8, 12 or 16
Sampling rate, adjustable per channel	20 Hz .. 50 kHz
Usable signal range	DC .. 20 kHz
Voltage / current measurement ranges	$\pm 25\text{ V} / 0 \dots 20\text{ mA} / 4 \dots 20\text{ mA} / \text{free}$
Signal conditioning, switchable from software	None, AC coupling, IEPE
Resolution / input impedance	24 bit / 4 M $\Omega$
Dielectric withstand voltage	$\pm 100\text{ VDC}$
Galvanic isolation: channel to channel / channel to system	$\pm 400\text{ VDC}$
Measurement accuracy	0.5 mV + 0.008 % of measured value
Digital inputs	4
Input signals	low: 0 .. 1 V / high: 5 .. 100 VDC@3.5 mA
Galvanic isolation: channel to other channel types / channel to system / PE	$\pm 400\text{ VDC}$
Max. input frequency / min. pulse width	1 MHz / 500 ns
<b>Analog outputs</b>	
Resolution	16 bit
Output ranges	0 .. 10 V / $\pm 10\text{ V} / 0 \dots 20\text{ mA} / 4 \dots 20\text{ mA} / \pm 20\text{ mA}$
Galvanic isolation: channel to other channel types / channel to system / PE	$\pm 400\text{ VDC}$
Min. load / max. burden	650 $\Omega$
<b>Digital outputs</b>	
Max. switching voltage / current	50 V / 2.5 A for 2 sec., 1 A for continuous current
Galvanic isolation: channel to other channel types / channel to system / PE	$\pm 400\text{ VDC}$
PWM basic frequency / duty cycle	5 Hz .. 10 kHz / 1:1000
<b>Data storage</b>	
Internal / external	2 .. 14 GB (approx. 30 million measurement values per GB) / USB, NFS, CIFS, (S)FTP
<b>Signal processing functions: high pass / low pass / bandpass filters</b>	
Cut-off frequency / filter order / filter characteristics	5 Hz .. 20 kHz / 2, 4, 6, 8, 10 / incl. Butterworth



<b>Integrator / Differentiator</b>	
<b>Single or double integrator / differentiator</b>	
<b>FFT</b>	
<b>Number of lines / window functions / averaging</b>	100 .. 12.800 lines / von Hann, Hanning, Flat-Top / 2 .. 32 fold
<b>FFT types</b>	Narrow band / wide band, envelope / demodulation, amplitude / phase spectra
<b>Characteristic values from time signal</b>	
<b>Characteristic values</b>	Max. / min. value, peak-to-peak value, arithm. average, TRMS, max vect. sum, local min. / max. values
<b>Characteristic values from frequency spectrum</b>	
<b>Characteristic values</b>	Amplitude, frequency and phase of main vibration and any harmonic, sum value, quadratic mean (in any frequency bands), residual value
<b>Characteristic values on digital input</b>	
<b>Frequency</b>	0.2 Hz .. 1 MHz
<b>Counter</b>	64 Bit, UP-Down counter, quadrant decoder
<b>Interfaces</b>	
<b>Mechanical type COM 1 / COM 2</b>	RS485, 9-pole Sub-D-plugs, DIN EN ISO 19245-1
<b>Mechanical type COM 3</b>	RS232, 9-pole Sub-D plugs
<b>LAN</b>	1 x 1000Base-TX
<b>WLAN / WWAN (optional)</b>	802.11b/g/n / GPRS, UMTS, LTE mx. 100 Mbit/s
<b>USB</b>	Device 2.0 / Host 2.0 / low / high / full
<b>PROFIBUS</b>	2 x PROFIBUS DPV1 / Slave max. 12 Mbit, also redundant complying to PNO 2.212 V1.2
<b>CAN / RS 232/485</b>	2 x CAN 2.0 / Modbus RTU, SCPI, ASCII
<b>TCP/IP</b>	Modbus TCP, OPC UA
<b>General technical information</b>	
<b>Dimensions / Weight</b>	W 210 x H 80 x D 125 mm / 750 g
<b>Mounting</b>	Rail mounting DIN EN 60715 or screw fixing
<b>Signal connectivity</b>	Plug-in screw terminals, 96 terminals in 2 rows, max. 1.5 mm <sup>2</sup>
<b>Temperature range</b>	-20 .. 50° C
<b>Supply voltage</b>	12 .. 24 VDC / ± 10%
<b>Power consumption</b>	max. 20 W

Delphin Technology AG  
Lustheide 81  
51427 Bergisch Gladbach · Germany

Phone +49 (0) 2204 97685-0  
Fax +49 (0) 2204 97685-85  
info@delphin.de · www.delphin.com





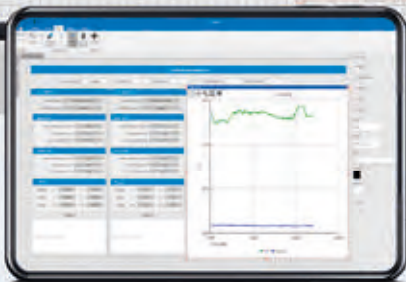
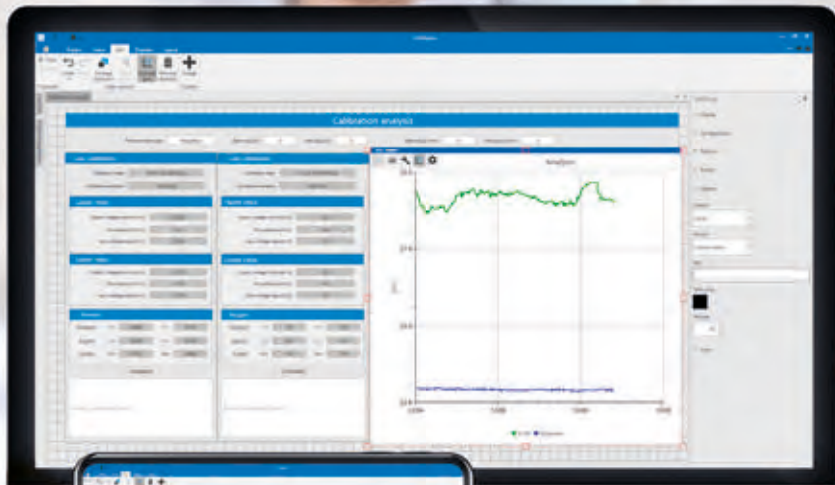

# Product catalogue

Measuring. Testing. Automation.



# Contents



## Company

### Product overview

#### Measurement and testing devices

ProfiMessage

ProfiMessage D

Expert Vibro

Expert Logger

Expert Transient

Expert Key

Loggito

LoggitoLab

LogMessage 5000

Software channels

#### Software

ProfiSignal 20

ProfiSignal 20 Go

ProfiSignal 20 Basic

ProfiSignal

ProfiSignal Go

ProfiSignal Basic

ProfiSignal Klicks

ProfiSignal Web

Delphin Data Center

ProfiSignal

Interfaces, Runtime, Viewer

ProfiSignal Options

Vibro, Audittrail, AlarmManagement, SQL

#### Complete systems

Measuring case / 19" systems / control cabinets

Universal testing device /

64-channel thermocouple measurement device

#### Solutions for industries

Chemicals, pharmaceuticals, plastics / Mechanical engineering

Energy technology / Heating, air-conditioning, ventilation

#### Services

Application development

Calibration

Training / Installation / Service agreements

## Your **partner** for industrial **measurement and testing technology**

**Since 1980, Delphin Technology AG has been developing, manufacturing and marketing pioneering, high-quality measuring hardware and software solutions for industrial measurement and testing technology.**

We are a competent and reliable partner to worldwide customers – both for standard measurement systems and individualised complete systems. Our team of technical specialists are committed to their work and transform creative ideas into practical products. The main applications for our products range from measurement data acquisition and analysis, test stand automation and monitoring through to vibration measurement technology. Our products are being used in a wide variety of sectors, including electrical engineering, mechanical engineering, energy technology and the chemical and pharmaceutical industries.

### **Continuity – Focussing on customers**

We focus on our customers who then benefit from our technical know-how and our proven practical experience in applications from almost 40 years of development work in the field of industrial measurement technology. Working closely with customers and their applications is important to us and is reflected in our product range as well as in our long-standing customer relationships. Many medium-sized companies, globally renowned industrial groups as well as research laboratories, authorities and universities place their trust in us and benefit from our many years of experience.

### **Quality – Made in Germany**

A top priority is the continuous development of our products in accordance with the highest quality standards. Delphin Technology AG is certified according to ISO 9001:2015. This ensures that our products meet the most stringent quality requirements to provide reliable operation in your applications. With Delphin, you have the assurance that the products have been “Made in Germany”.

### **Innovation – Intelligent measurement technology**

Through continuous technological development, we aim to supply our customers worldwide with intelligent and universally usable data acquisition devices and intuitive measurement software. Our customers must be able to carry out their measurement and monitoring tasks at high-levels of efficiency and safety. We support you with our deep knowledge of products and applications and we are constantly working on new technical features and innovations which are protected by worldwide patents.

### **Flexibility – Individualised complete systems**

Flexibility and a non-hierarchical organisation are further building blocks in our corporate philosophy. This enables us to respond to the wishes of customers and to offer individualised complete solutions in addition to standardised systems. On request, we can manufacture individualised measuring cases, control cabinets and complete test stands and, with ProfiSignal software, program application software specifically tailored to your requirements.

### **Customer service**

Customer service is our number one priority. Our range of services includes project planning, installation, calibration, service hotline and training courses as well as project-based and individualised training. Installation and training are carried out by a competent team of experienced engineers at Delphin or at the customer’s premises. Our service packages guarantee you first-class support from the outset!





## Intelligent **measurement technology**

“We at Delphin supply our global customers with intelligent, universal data acquisition hardware and intuitive measurement software. This enables our customers to reliably and efficiently carry out their measurement and monitoring requirements.”





© Max-Planck-Institut für Radioastronomie



## Data acquisition and data logger

## Test, trial & automation



**Loggito**  
Compact data acquisition



**LoggitoLab**  
Compact data measurement lab



**Expert Logger**  
Stand alone data logger

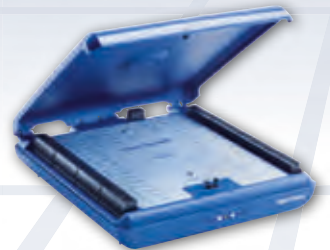

**Expert Key**  
PC-based measurement technology



**ProfiSignal 20**  
Intuitive measurement software



**ProfiSignal Go / ProfiSignal Basic**  
Data acquisition and analysis,  
Operation and observation

**ProfiSignal Kicks**  
Automate and control

# Measurement technology globally networked



**Vibration measurement**



**Monitoring & environment technology**

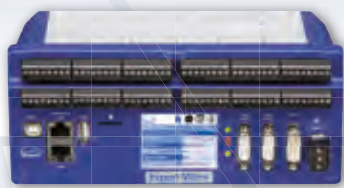

**Expert Vibro**  
Vibration measurement



**ProfiMessage**  
**ProfiMessage D**  
Modulare measurement technology and automation



Compact measurement system

**Expert Transient**  
Transient data acquisition



**ProfiSignalWeb**  
Web-based and mobile data acquisition





# Expert Vibro – The **vibration specialist**

Focusing on your systems! We show you how to see behind the scenes of your installation and gain a detailed picture of its condition. Acquiring vibration data and processing it online.

Vibration measurement becomes understandable with Expert Vibro. State-of-the-art processor technology in a compact design enables 4, 8, 12 or 16 synchronous vibration measurement channels with sampling rates of up to 50 kHz per channel, tailored to your needs. 24-bit A/D converters guarantee extremely high precision.

Flexible switching is possible between measuring voltages, currents, IEPE or shaft vibration sensors. Integrated comparators and digital inputs enable flexible and speed-synchronised triggering. Measurement data is monitored online and digital outputs can be switched in milliseconds when limit values are exceeded. Process data can also be recorded by using the relevant modules.

Vibration measurement using Expert Vibro is easy, even for newcomers. Intuitive configuration guarantees fast installation and short learning times.



Expert Vibro

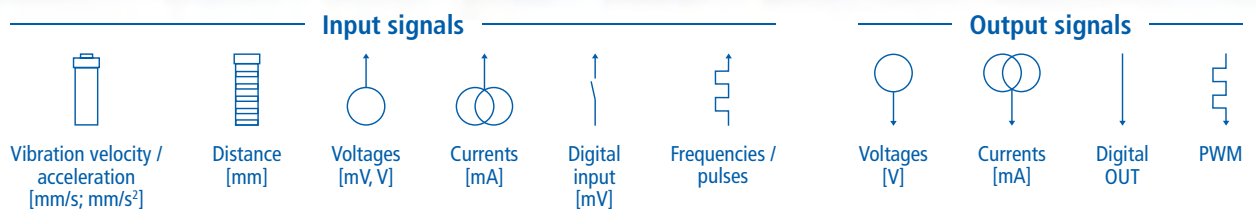

Inputs / outputs	Type 4	Type 8	Type 12	Type 16
Analog inputs (mV, mA)	4	8	12	16
Analog outputs (mV, mA)	4	4	4	4
Digital / frequency inputs	4	4	4	4
Digital outputs	8	8	8	8

## Applications

- Shaft vibration monitoring and analysis
- Monitoring of vibrations in machines and housings
- Rolling bearing monitoring and bearing damage diagnosis
- Spindle monitoring and balancing
- Combustion chamber vibration monitoring
- Gearbox vibration analysis
- Air-gap monitoring
- Mobile vibration measurement

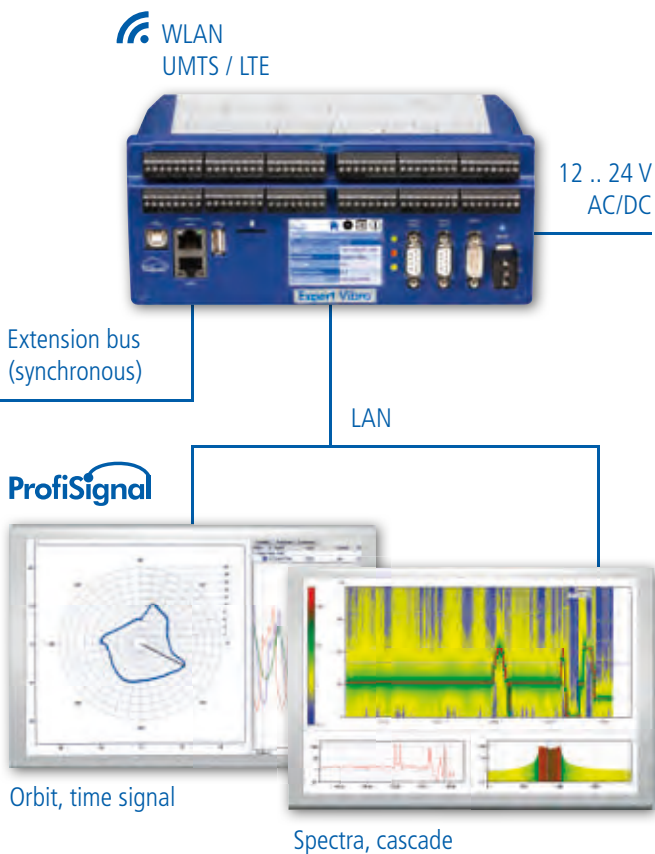

## Interfaces

- Modbus TCP/RTU
- PROFIBUS DP, CAN RAW
- RS232, RS485

- OPC UA\*



## Product features

- 4, 8, 12 or 16 individually triggerable vibration inputs
- Calculation and monitoring of characteristic values
- Online computation of measurement data
- Integrated analysis functions for gear and roller bearing monitoring, air-gap etc.
- Spectrum – online – up to 12,800 lines (FFT)
- Integration functions (two-stage)
- 50 kHz sampling rate per channel
- 24-bit A/D converter

## Sensor connection

- Software switchable analog inputs
  - Shaft vibration / distance sensors
  - Acceleration sensors
  - Vibration velocity sensors
  - mV / mA signals (pressure etc.)
- Switchable IEPE power supply
- Integrated comparators for KeyPhasor® sensors
- Measuring range up to  $\pm 25$  V
- Pluggable screw terminals

## Interfaces

- LAN, USB, WLAN (optional), LTE (optional)
- Serial interfaces RS232, RS485
- OPC UA\*, Modbus TCP/RTU
- PROFIBUS DP, CAN RAW
- Individual ASCII protocols

## Data storage

- 2 GB or 14 GB internal storage
- External storage media (USB, NAS)
- Triggered storage with pre and post histories

## Product highlights

- Synchronous analog inputs, 50 kHz sampling rate per channel
- Calculation and monitoring of characteristic values
- Spectrum – online – up to 12,800 lines (FFT), integrated IEPE power supply
- Extendible



# Software Channels – Flexible and **autonomous**

Do you want to control your application in real-time independent from PC and network? Delphin's software channels provide tools to efficiently meet your needs.













Software channels are predefined function modules that are individually created, configured and processed by the user at a mouse click. For example, measurement data can undergo online processing using calculation channels. Limit value channels monitor measurement data and trigger alarms or send emails in the event of deviations. Experiment procedures can be fully configured using software channels, and undergo automatic processing.

The number of software channels available is practically unlimited. All functions are carried out autonomously by a powerful processor in the Delphin device and thus guarantee fully secure operation. By using software channels, data acquisition becomes a complete system for automation, monitoring and online analysis.





# monitoring

	Description	Application example
<b>Online analysis</b>		
 <b>Calculation channel</b>	Any number of channels can undergo calculations with each other, Functions include: basic arithmetic operations, trigonometry, binary and Boolean functions	Temperature difference between two input temperatures
 <b>Mean-value channel</b>	Calculates moving and triggered mean values	Mean of highly sensitive signals from thermocouples
 <b>Edge counter</b>	Counter for pulses (up, down and reset function)	Energy pulses to count kWh
 <b>Differentiator</b>	Calculates changes over time	Gravimetric dosing in laboratories
 <b>Integrator</b>	Numerical integration over time	Calculating volumes from flow rates
 <b>Summation channel</b>	Time-independent addition of measurement data	Totalling of analog measurement data
 <b>Linearisation</b>	Corrective calculations for non-linear sensors	Linearisation of application-specific PTC sensors
 <b>Operating hours</b>	Accumulates high-level time-points in digital signals in hours	Determining on / off time ratios for a machine
 <b>Statistics</b>	Calculates moving and triggered statistical values (min, max, variance, standard deviation)	Determining maximum values in an experiment
 <b>Stopwatch</b>	Times between two events	Determining switching times for valves and thermal switches
<b>Monitoring</b>		
 <b>Limit</b>	Generates an event when limit values exceeded (exceeds / falls short, persistence, hysteresis bandwidth monitoring)	Alarm when a bearing temperature is exceeded
 <b>Combined</b>	Generates alarms from multiple digital input channels	Alarm from different parts of a system are combined into one message
 <b>Wake-up</b>	Generates pulses according to absolute calendar times (once per day, week, month ...)	Determining daily production statistics
 <b>Status</b>	Evaluates status information in a measurement data and generates alarms	Alarms for wire breaks in an mA signal
 <b>System</b>	Displays system information (CPU load, memory utilisation ...)	Alarms for full data storage capacity
<b>Automation</b>		
 <b>Setpoint channel / sequencer</b>	Automatically executes setpoint curves with reset, hold and start triggers	Automatic management of chemical processes temperatures / stirrers
 <b>FlipFlop channel</b>	RS, JK, D FlipFlop	Storage of digital statuses and analog data for further processing
 <b>Pulse generator</b>	Generates cyclic pulses	Time synchronising every 15 min. Energy counter reset
 <b>Logic channel</b>	AND, OR, NOT, XOR, NOR ...	Boolean linking of any digital signal
 <b>Timer channel</b>	Functions for time elements (pick-up and drop-out delay)	Time-delayed starting of experiment procedures
 <b>Flag channel</b>	Stores constants and parameters	Process constants and control via GUI

# ProfiSignalGo – Just a few steps to go from **sensor**

Do you want to immediately begin recording and analysing measurement data? Then opt for the very easy-to-use ProfiSignal Go software.

ProfiSignal Go is Windows based software that requires just a few steps to visualise measurement data in a range of diagram types, as well as to monitor the data, analyse it, archive it as a file, and export it directly in ASCII format as a CSV file. During ongoing measuring, you can access historical measurement data without interrupting the current measuring process and thereby compare actual to past data. A range of cursor functions and flags are available to mark and process critical measurement data.

ProfiSignal Go is rounded off with statistical and online / offline calculation functions to facilitate test evaluations. Optional interfaces such as the OPC server / client, Modbus TCP and an open programming interface are also available to connect a wide variety of peripherals as well as Delphin's measurement and testing devices.

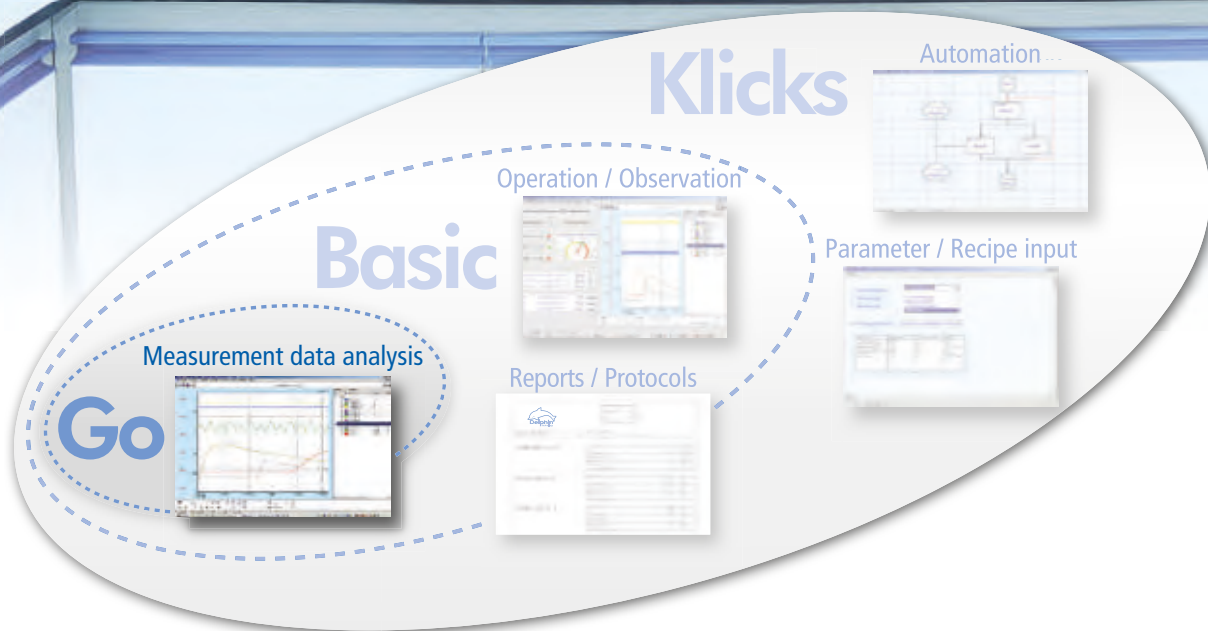

## Applications

- Process data acquisition and analysis
- Laboratory data acquisition
- Measuring during system installation
- Fault value analysis with recorder functions
- Mobile and stationary data acquisition
- Trials and testing
- Measuring for servicing and maintenance

## Product features

- Monitoring and analysis of any measured values
- Various diagram types for data visualisation (online / offline)
- Smooth switching from online to offline data
- ASCII export as CSV file / Trend export as vector-based EMF file
- Statistical and offline calculation functions
- Analysis using cursor functions down to  $\mu$ -second ranges
- Evaluation of digital signal sequences
- Permanent storage in database format
- Recording of batch-based tests to separate files
- Alert functions via email and fax
- Display of diagram functions

## Diagram types

- y(t) diagram
- y(x) diagram
- Characteristic curve diagram
- Oscilloscope diagram
- Digital logic diagram

## Interfaces and options

Further information can be found on pages 46, 48.

## Product highlights

- Simple operation from measurement data to trend
- Monitoring and analysis of any measurement data from any source (hardware and software)
- Many diagram types available
- Versatile interfaces for connecting peripherals
- Statistical evaluation and offline calculation functions
- From a general overview to high-resolution  $\mu$ sec ranges in just a few steps
- Direct export as CSV file or trend export as EMF file
- Up to four y-axes are possible to enable different measurement units in one diagram





# ProfiSignal Basic – Visualisation and operation

Do you need a simple solution for monitoring applications and process visualisation? Then ProfiSignal Basic is the right choice.

ProfiSignal Basic is a complete software package that enables you to create individual diagrams using a wide range of operating and monitoring objects. Both continuous processes (e.g. operational data acquisition) and noncontinuous measuring tasks (e.g. test measurements) can be visualised, operated and monitored without any programming effort. The operating and monitoring diagrams are simply created by combining and configuring elements. Pre-configured basic functions are available for operating test stands and automating measurement tasks.

For logging purposes, basic reports, e.g. with header data, diagrams and annotation fields, can be created on a time-controlled basis.

ProfiSignal Basic includes all ProfiSignal Go features and its many diagram types, and archiving and export tools, to provide your applications with a wide range of functions.



## Applications

- Condition monitoring
- Operational and process data acquisition
- Trials and testing
- Systems and machine monitoring
- Energy data acquisition and monitoring
- Acquisition and visualisation of laboratory data
- Clean room monitoring

## Product features

- Multiprocessing – independent execution of multiple applications
- Versatile operating and monitoring functions
- Base functions for automation
- Monitoring and analysis of any measured values
- Reporting

## Operating and observation objects

- Buttons, slide and toggle switches
- Input fields, dropdown lists and check boxes
- Analog and digital displays, signal lamps
- Tanks
- Tables
- Images for customised design
- Background images e.g. system schematics, drawings, photos

## Diagram types

- $y(t)$  diagram
- $y(x)$  diagram
- Characteristic curve diagrams
- Digital logic analysis
- Oscilloscope diagram

## Interfaces and options

Further information can be found on pages 46, 48.

## Product highlights

- Intuitive creation of diagrams without programming
- Includes preconfigured operating and monitoring elements
- Optimally usable both for the monitoring of continuous processes and for batch and experiment measurements
- Basic functions for automation available
- Report generation



ProfiSignal with a Basic visualisation



# ProfiSignal Kicks – The **complete package** with

Do you want to be able to automate your experiments and measurement needs independently from programming experts and without requiring programming expertise? Then use the unique development environment of ProfiSignal Kicks and create your applications using “programming by selection”!

ProfiSignal Kicks was developed by engineers for engineers. Without extensive training and with the aid of ready-made context menus and program texts, Kicks allows you to automatically create applications including visualisation and process flow control. As a user, learning a programming language is not required. A structure view enables you to structure each step in your application in a clear and interconnected way, so you always keep an overview. The creation of individual reports, which can be automated according to your test procedure, considerably reduces documentation effort.

ProfiSignal Kicks is the complete software package and contains all the functions from ProfiSignal Go and ProfiSignal Basic.





# all options

## Applications

- Test stand automation with visualisation and operation
- Creation of process controls
- Management of test parameters and recipes
- Laboratory automation
- Product testing
- Automation of measuring tasks

## Product features

- Automation functions through ready-made context menus and program texts
- Creation of recipes and management of test parameters
- Versatile operating and monitoring functions
- Synchronous / asynchronous execution of multiple applications through multiprocessing
- SQL interface for database connection
- Creation of detailed, individualised reports

## Operating and observation objects

- Buttons, slide and toggle switches
- Input fields, dropdown lists and check boxes
- Analog and digital displays, signal lamps
- Tanks
- Tables
- Images for customised design
- Background images e.g. system schematics, drawings, photos

## Diagram types

- $y(t)$  diagram
- $y(x)$  diagram
- Characteristic curve diagram
- Digital logic analysis
- Oscilloscope diagram

## Interfaces and options

Further information can be found on pages 46, 48.

## Product highlights

- Complete software for visualisation, automation and operation of a full range of measuring and testing requirements
- “programming by selection” – automate processes and test tasks without a programming language
- Clear structure diagram simplifies maintenance of the application
- Automatic generation of detailed, individualised reports
- SQL interface available for connecting to databases

# Delphin Data Center – Centralised measurement

How are your measurement requirements changing in the face of Industry 4.0 and IIoT? Are many of your measurement application isolated systems? Is measurement data being stored in different formats and different platforms? With the Delphin Data Center, you now have a solution which enables you to set up your own measurement data management without time-consuming and costly programming.

Cross-process data processing and analysis is often tedious and involves extensive manual effort or extensive programming work. Usually no uniform data structure exists, especially in machine parks that have developed over time. The Delphin Data Center brings together and synchronises data from different sources. The Delphin Data Center's open structure creates a central data pool to enable you to standardise, archive and monitor measurement and process data in a simple way. A wide range of applications can then be implemented for inspection requirements, life cycle testing, the monitoring of systems and machines, locally or worldwide.



# data management

## Applications

- Condition monitoring of machines and systems
- Operational and process data acquisition
- Service life testing and long-term archiving
- Synchronisation of worldwide measurement / monitoring tasks
- Data standardisation and conversion
- FDA-compliant applications / clean room monitoring

## ProfiSignalWeb Worldwide distribution



## Monitoring and alerting



## Data management

- Centralised data collection from distributed sources
- Continuous and batch-based archiving
- Loss-free compression algorithms
- Lightning fast access from ms to yearly viewing
- Special data preprocessing via software channels
- Smooth transition from online to historical data
- Access via any number of clients (license packages)

## Alarm management

- Create alarm conditions and rules
- Detailed alarm list with options for confirmation
- Notification by email and text messaging
- Audit trail for FDA compliant applications

## User management

- Password management
- Management of user rights
- Client management

## Data interfaces

- OPC DA Client / Server
- Modbus TCP Master / Slave
- ASCII-DLL
- API interface
- SQL interface and ODBC
- Individual drivers incl. configuration dialogs

## Product highlights

- Easy to use, implementation without programming
- High-performance data archiving with lightning-fast access
- Loss-free data compression
- Extendible via web servers for platform-independent access
- Processing of up to 10 million data records per second



Expert Vibro

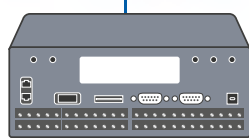

Third-party hardware  
OPC UA, SPS/PLC, Modbus TCP Server

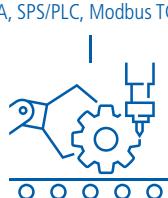



# ProfiSignal – Interfaces, Runtime, Viewer

Do you want to connect external software and hardware to your ProfiSignal application, perform finished projects without a development environment, or analyse measurement files and reports offline? We have the solution.

Drivers for high-speed data transfers are available for exchanging data with third-party software and hardware. You can use ProfiSignal to connect sensors and other control and measurement systems via a variety of interfaces. An API interface enables ProfiSignal to also be integrated into higher level programming languages.

Once a ProfiSignal project has been developed, it can be easily performed with a Runtime license without the possibility to make any changes to the application. The Runtime version contains all the ProfiSignal options available in the development version.

The ProfiSignal Viewer allows you to perform offline analysis of measurement data and reports created with ProfiSignal. It is ideal when measurement data is to be analysed and exported only and no applications or online data are required.

## Product highlights

- **ProfiSignal interfaces:**  
A broad range of interfaces for connecting third-party software and hardware
- **ProfiSignal Runtime:**  
Tamper-proof execution of ProfiSignal projects
- **ProfiSignal Viewer:**  
Easy offline analysis of measurement data





# ProfiSignal – Options

Do you have a vibration measurement application or do you have special requirements regarding validation, alarm management or data exchange? Then add the relevant option to your ProfiSignal package.

The Vibro option supplements existing ProfiSignal functions with special diagrams for vibration measurement, FFT, cascade, time signal, Bode diagram, envelope as well as orbit and spectrogram.

The Audittrail / FDA option provides functions in ProfiSignal Basic or Klicks for validating monitoring applications according to the FDA 21 CFR Part 11 guidelines.

The AlarmManagement option supplements ProfiSignal Basic or Klicks with important functions for monitoring and alerting.

The SQL option connects ProfiSignal measurement data with company and product databases as well as ERP systems (only for ProfiSignal Klicks).

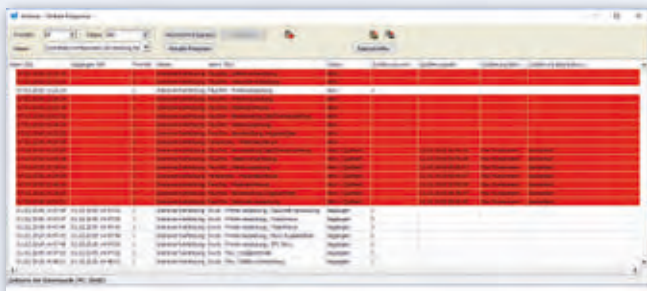

Alarm ID	Alarm Name	Priority	Category	Status	Message
1	High Vibration	High	Vibration	Active	High vibration detected at 10:00:00
2	Low Pressure	Medium	Pressure	Inactive	Low pressure detected at 09:55:00
3	Temperature Rise	Low	Temperature	Inactive	Temperature rise detected at 09:50:00
4	Oil Level Low	High	Oil Level	Active	Oil level low detected at 10:05:00
5	Motor Overload	High	Motor	Inactive	Motor overload detected at 09:45:00

Alarm table

## Applications

- **Vibro option:** Shaft vibration diagnosis and monitoring of gas / steam or hydropower turbines, compressors and drives as well as bearing vibration monitoring and roller bearing diagnosis on electric drives and rollers
- **Audittrail / FDA option:** Monitoring of applications requiring validation according to FDA 21 CFR Part 11 and data integrity through tamper-proof measurement databases
- **AlarmManagement option:** Applications with extra requirements for alarm management
- **SQL option:** Applications requiring connections to a company database or ERP system

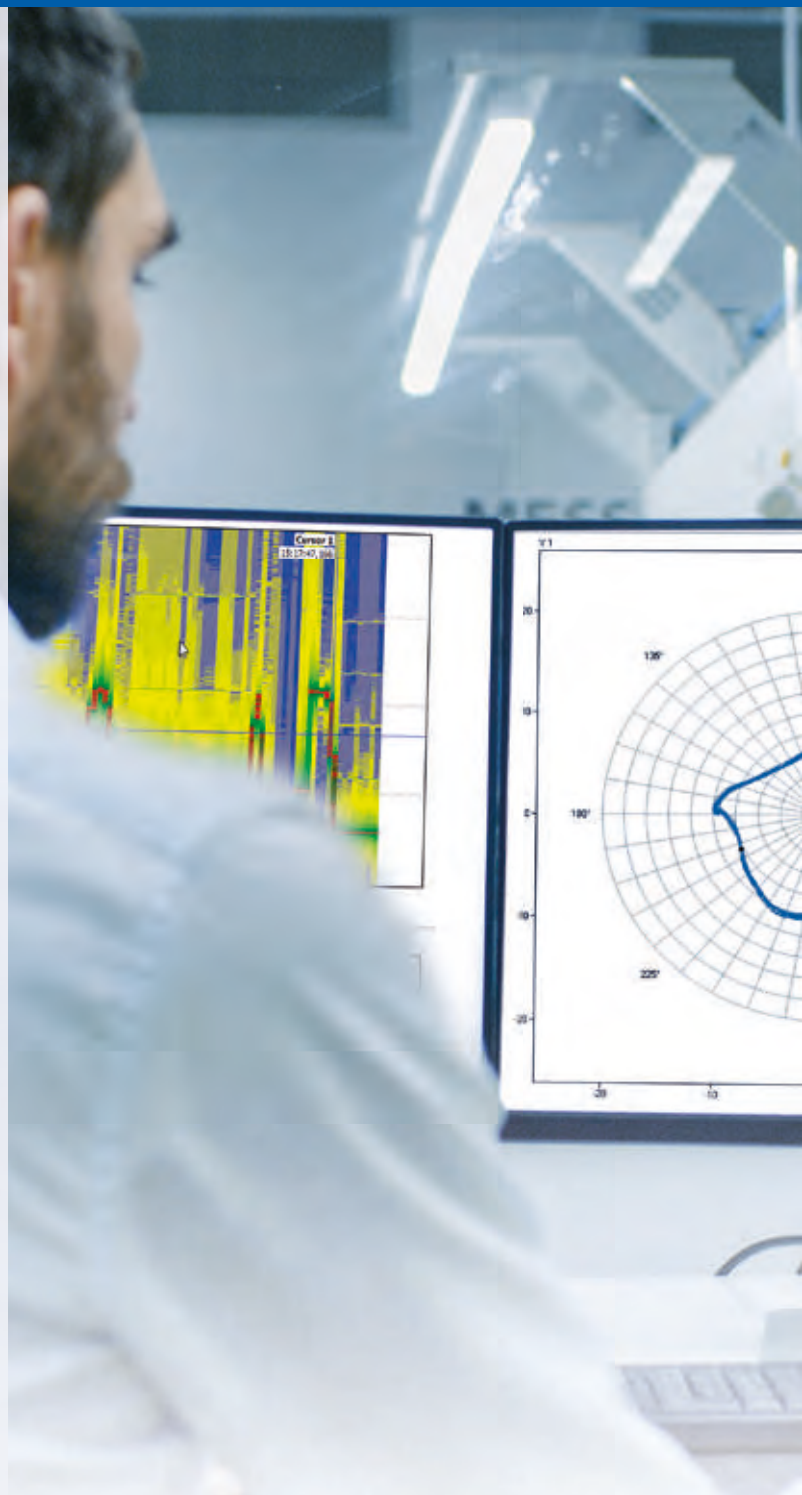



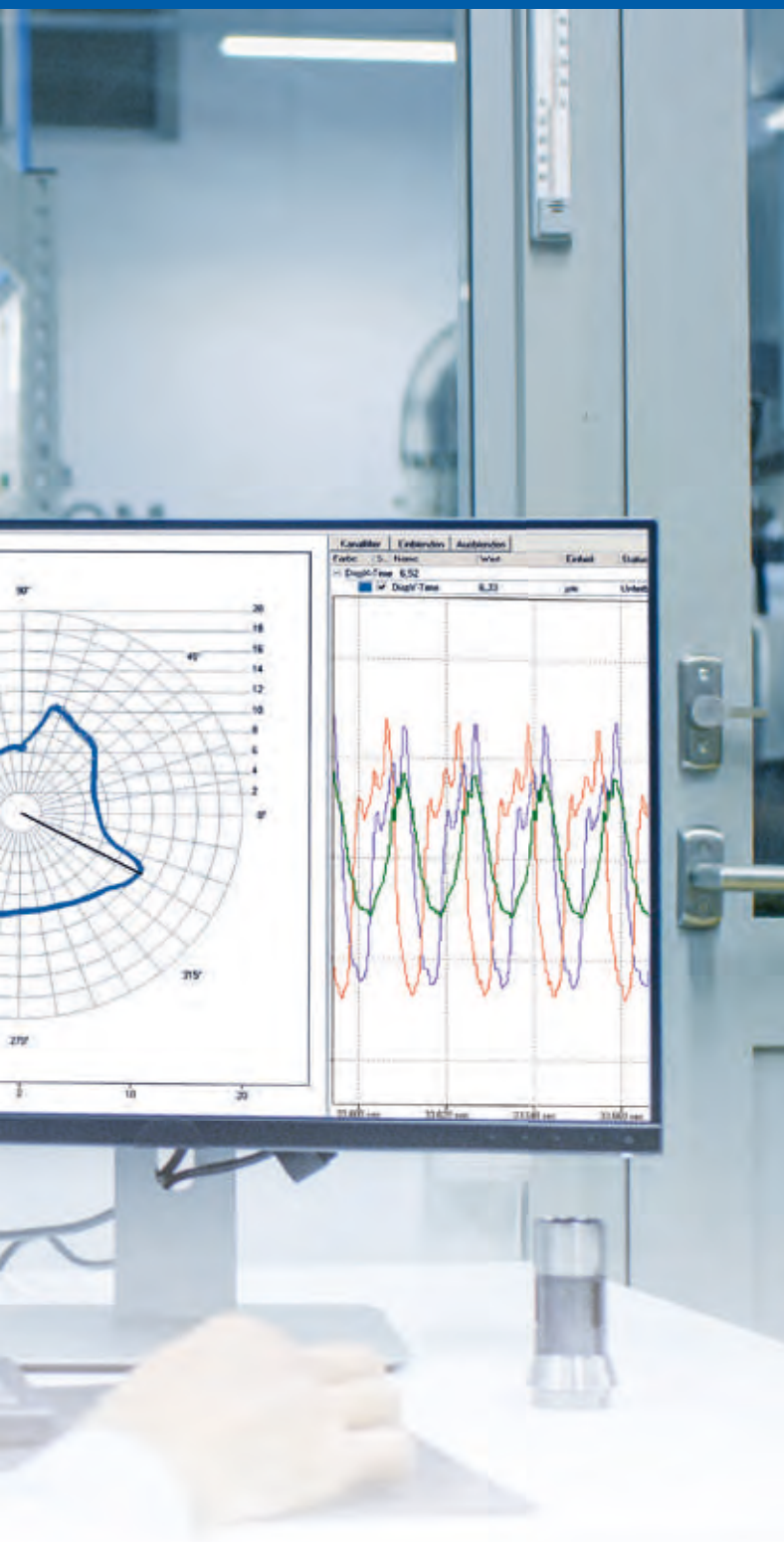

### Vibro option features

- Addition to ProfiSignal of special vibration measurement diagrams time signal, orbit, shaft centerline, polar, FFT, envelope, cascade, order analysis, spectrogram and bode
- On / offline display, evaluation of data measured with Expert Vibro
- Acquisition, visualisation and analysis of process and vibration measurement data in one system
- Documentation of vibration data via a report generator with access to all special diagrams

### Audittrail / FDA option features

- User management with different authorisation levels
- Integrated alarm management with rights-dependent access to alarm lists and alarm confirmations with comments only
- Redundant tamper-proof archiving of measurement data on a server as well as directly within the acquisition hardware
- Logging of user interventions (according to user management) for hardware configuration changes as well as software changes and operating control elements on a PC (Audittrail)
- Regular automatic report generation on recorded measurement data, alarm incidents and user interventions

### AlarmManagement option features

- Structured creation of alarms and alarm classes
- Alarm recording with date and time, accurate to the millisecond
- Continuous logging of alarms in a separate alarm archive
- Extensive filter functions
- Analysis and access to both online and historical data with direct access to an alarm including pre- and post-alarm histories

### SQL option features

- Integration of an SQL interface for data exchange with other databases, e.g. for test sample parameters
- Connection to ProfiSignal via ODBC functionality to enable reading / writing of data

# ticals, plastics and mechanical engineering



## Mechanical engineering

Increasingly complex systems and controls raise the demands on data acquisition and fault analysis. Systems are becoming increasingly connected and more intensively monitored with large volumes of data needing to be analysed in real time for services such as predictive maintenance. The need for intelligent measurement and test solutions and the demand for efficient complete solutions is increasing.



**You can find more solutions for industries:**  
[www.delphin.com](http://www.delphin.com)

## Application highlights

- Turnkey systems to guarantee fast availability, optimum controllability and reliable operation
- Data acquisition and monitoring in an intelligent system with quick and easy configuration and short set-up times
- Flexibility from having diverse (fieldbus) interfaces and support for open standards such as OPC UA
- Autonomous operation guarantees reliable data acquisition and storage with time stamps, even in the event of PC or network failures
- Integrated signal conditioning in place of external transducers
- Acquisition and evaluation of measurement data, automation and visualisation of measurement procedures and processes, automated report generation – all without requiring programming expertise
- Simple creation of system monitoring with a range of alarm options as well as fault value analysis with pre and post triggering



# Application development

## Individual and efficient

Do you need a turnkey solution for your measurement or automation requirements? We at Delphin guarantee smooth project completion, from engineering and implementation through to user training. Using Delphin products, our engineering team efficiently and cost-effectively create individualised applications. This can include configuring measuring points, visualisation in ProfiSignal Basic, system automation and protocols in ProfiSignal Klicks or complete project planning and control cabinet construction by Delphin.

Application development is based on the ProfiSignal system. You can then subsequently maintain and develop the application we have created. Our engineers have been working for years with our products and are therefore able to deliver effective and practical solutions. Benefit from our many years of experience in delivering projects for specific customer needs and choose application development from Delphin.



 **You can find more application examples online:**  
[www.delphin.com](http://www.delphin.com)





### Other application examples

- Complete development test stands with the input of header data and product data, test procedure programming, standards-compliant protocols and calculations, e.g. for:
  - Luminaires
  - Tools
  - Motors
  - Vehicle components
  - Boilers and heating systems
- Process visualisation with data archiving and analysis functions, e.g. for:
  - Laboratories
  - R & D applications
  - Processing plants
- Final test systems with traceable, server-based data archiving and automatic printout of protocols for specific products
- Room monitoring and alarms via email, text messaging and fax, controlled by a powerful system of user management
- Vibration monitoring of engines, generators and turbines with worldwide accessibility to measurement data

 **You can find more application examples online:**  
[www.delphin.com](http://www.delphin.com)

# Calibration

## Precision and security

Wherever measuring devices are being used for quality-based tasks, the devices require calibration. Even the smallest measurement errors can have drastic effects on the safety of production processes and on the quality of products. During calibration, measurements are carried out on the instrument to be tested and compared with reference values. This reassures users that measurements post calibration have a specific degree of accuracy. Every measuring system produced by Delphin leaves our factory calibrated and compliant to national standards according to ISO 9001.

We provide device and system recalibration at any time post purchase. As a manufacturer, we can re-adjust for deviations (if necessary) as part of a calibration, and carry out full functional testing. This guarantees reliability and accuracy over the entire period of use. We offer calibration at Delphin's premises or directly at the place of use.

For both on-site and in-house calibration at Delphin, you receive a calibration certificate for the device that complies to national standards. You have the option of DAkkS or factory calibration.



Mobile calibration system





## Calibration at Delphin

Calibration at Delphin makes sense when you have periods when you are not using the equipment. Arrange an appointment with our calibration department and send in the devices.

## On-site calibration

Larger machines and systems cannot be easily dismantled for calibration. For more complex systems, there is also risks involved in transportation. We then recommend that you have your equipment calibrated on site. For this purpose, we have modern and mobile calibration equipment which allows us to calibrate directly on your system and, if necessary, also to readjust it.

## Advantages of on-site calibration

- Minimal downtimes because the devices and systems remain in-house
- Measuring operations can continue because devices are calibrated one after the other
- The devices and systems are calibrated under actual ambient conditions
- Calibration takes place on an agreed date
- No effort or costs concerning dismantling, shipping and reassembly
- No transportation risks for the devices



# Services

## Training

Do you want to quickly and simply find out about the range of application options for Delphin measuring and testing devices and software? Or do you need support with implementing a specific application?

Then choose one of our regular basic or advanced training courses, or arrange an individual training course in which your specific questions will be dealt with according to your needs. Training can take place in the modern conference rooms at Delphin as well as at your premises.

Contact us and we will be happy to help you.

## Installation

To enable you to use your Delphin system as quickly as possible, we offer system installation at your premises by our qualified service engineers. We will make an appointment with you for this purpose. Installation includes the following:

- Setting up the Delphin measuring hardware
- Setting up the ProfiSignal software
- Miscellaneous e.g. cabling work
- Operating instructions

Installation therefore includes optimal configuration of your systems and training of your personnel. This makes using our products as easy as possible.

Give us a call and we will be happy to advise you.





### Rental contracts including software maintenance

Do you find that regularly checking whether your measurement technology software is up-to-date requires too much effort? Then opt for the rental variant of ProfiSignal. You can then stay up-to-date with the latest software version while also enjoying premium customer support for any queries you have.

All ProfiSignal rental licenses include the following services:

- Premium support by telephone and remote maintenance via internet with prescribed response times
- Free software updates for your ProfiSignal installation

[Contact us if you require more information.](#)

### Service agreements

Does the availability of your systems have top priority for you, no matter whether you operate a production plant, supervise a research and development facility or are a service provider? Do you use, or plan to use, Delphin products for data acquisition, monitoring and control tasks?

Then invest too in a service agreement for the measuring equipment supplied by Delphin to ensure continuous functioning of your system.

Delphin service agreements include the following options:

- Premium support by telephone and remote maintenance via internet with prescribed response times
- Short, contractually agreed lead times for service calls, maintenance work and repairs
- Free software updates for your ProfiSignal installation

[Request an offer tailored to the needs of your systems and facilities.](#)



Delphin Technology AG  
Lustheide 81  
51427 Bergisch Gladbach · Germany

Phone +49 (0) 2204 97685-0  
Fax +49 (0) 2204 97685-85  
info@delphin.de · www.delphin.com





# Fișă tehnică produs

Specificatii



## Automat Programabil M241 24 I/O Tranzistor Pnp, Ethernet

TM241CE24T

### Principal

Gama de produse	Modicon M241
Tip produs sau componenta	Automat programabil
[Us] tensiune nominala de alimentare	24 V c.c.
Numar intrare discreta	14, intrare discretă 8 intrare rapidă conformitate cu IEC 61131-2 Tip 1
Tip de iesire discreta	Tranzistor
Numar iesire discreta	10 tranzistor 4 ieșire rapidă
Tensiune iesire discreta	24 V c.c. pentru ieșire pe tranzistor
Curent iesire discreta	0.5 A pentru ieșire pe tranzistor (Q0...Q9) 0.1 A pentru ieșire rapidă (mod PTO) (Q0...Q3)

### Suplimentar

Numarul I/O discrete	24
Numarul maxim de module de expansiune I/O	7 (local arhitectura I/O) 14 (de la distanță arhitectura I/O)
Limite tensiune de alimentare	20,4...28,8 V
Curentul de varf	50 A
Puterea consumata in W	32,6...40,4 W (cu numărul maxim de module I/O de expansiune)
Logica de intrare discreta	Derivatie sau sursa
Tensiune de intrare discreta	24 V
Tip tensiune de intrare discreta	C.c.
Starea 1 garantata a tensiunii	$\geq 15$ V pentru interior
Starea 0 garantata a tensiunii	$\leq 5$ V pentru interior
Curent intrare discreta	5 mA pentru interior 10,7 mA pentru intrare rapidă
Impedanta de intrare	4.7 kOhm pentru interior 2.81 kOhm pentru intrare rapidă
Timp de raspuns	50 $\mu$ s pornit, I0...I13 borne pentru interior 50 $\mu$ s oprit, I0...I13 borne pentru interior $\leq 2$ $\mu$ s pornit, I0...I7 borne pentru intrare rapidă $\leq 2$ $\mu$ s oprit, I0...I7 borne pentru intrare rapidă $\leq 34$ $\mu$ s pornit, Q0...Q9 borne pentru ieșire $\leq 250$ $\mu$ s oprit, Q0...Q9 borne pentru ieșire $\leq 2$ $\mu$ s pornit, Q0...Q3 borne pentru ieșire rapidă $\leq 2$ $\mu$ s oprit, Q0...Q3 borne pentru ieșire rapidă
Timp de filtrare configurabil	1 $\mu$ s pentru intrare rapidă

	12 ms pentru intrare rapidă 0 ms pentru interior 1 ms pentru interior 4 ms pentru interior 12 ms pentru interior
<b>Logica de iesire discreta</b>	Logica pozitiva (sursa)
<b>Limite pentru tensiune la iesire</b>	30 V c.c.
<b>Curent maxim pe comunul iesirii</b>	2 A cu Q0...Q3 terminal pentru ieșire rapidă 2 A cu Q4...Q7 terminal pentru ieșire 1 A cu Q8...Q9 terminal pentru ieșire
<b>Frecvența maximă de iesire</b>	20 kHz pentru ieșire rapidă (mod PWM) 100 kHz pentru ieșire rapidă (mod PLS) 1 kHz pentru ieșire
<b>Precizie</b>	+/- 0.1 % la 0,02...0,1 kHz pentru ieșire rapidă +/- 1 % la 0,1...1 kHz pentru ieșire rapidă
<b>Curent de fuga maxim</b>	5 μA pentru ieșire
<b>Cadere de tensiune maximă</b>	<1 V
<b>Incarcare tungsten maximă</b>	<2,4 W
<b>Tip de protecție</b>	Protecție la scurtcircuit Protecție la scurtcircuit și suprasarcină, cu repornire automată Protecție față de polaritate inversă pentru ieșire rapidă
<b>Resetare timp</b>	10 ms resetare automată ieșire 12 s resetare automată ieșire rapidă
<b>Capacitate memorie</b>	8 MB pentru program 64 MB pentru Memorie RAM
<b>Date cu copie de rezerva</b>	128 MB memorie flash integrată pentru copie de siguranță a programelor utilizator
<b>Echipament de stocare a datelor</b>	<= 16 GB card SD (opțional)
<b>Tip baterie</b>	BR2033 litiu, nereîncărcabilă, durata de viață a bateriei: 4 yr
<b>Timp rezerva</b>	2 ani la 25 °C
<b>Timp de execuție pentru 1 kiloinstrucțiune</b>	0,3 ms pentru eveniment #i task periodic 0,7 ms pentru altă instrucțiune
<b>Structura aplicație</b>	8 evenimente externe 8 evenimente 3 taskuri master ciclice + 1 task liber 4 taskuri master ciclice
<b>Ceas în timp real</b>	Cu
<b>Abaterea ceasului</b>	<= 60 s/lună la 25 °C
<b>Funcții de poziționare</b>	PTO funcția 4 canale (frecvența de poziționare: 100 kHz) PTO funcția 4 canale pentru ieșire pe tranzistor (frecvența de poziționare: 1 kHz)
<b>Număr intrări de contorizare</b>	4 intrare rapidă (mod HSC) la 200 kHz 14 standard input la 1 kHz
<b>Tip semnal de control</b>	A/B la 100 kHz pentru intrare rapidă (mod HSC) Puls/direcție la 200 kHz pentru intrare rapidă (mod HSC) Monofazat la 200 kHz pentru intrare rapidă (mod HSC)
<b>Tip de conexiune integrată</b>	Legătură serială neizolată serial 1 cu RJ45 conector și RS232/RS485 Legătură serială neizolată serial 2 cu cutie de borne cu suruburi amovibile conector și RS485 USB port cu mini B USB 2.0 conector Ethernet cu RJ45 conector
<b>Alimentare</b>	(serial 1)alimentare linie serială 5 V, <200 mA
<b>Rata de transmisie</b>	1.2...115.2 kbit/s (115.2 kbit/s implicit) pentru lungimea magistralei de 15 m pentru RS485 1.2...115.2 kbit/s (115.2 kbit/s implicit) pentru lungimea magistralei de 3 m pentru RS232 480 Mbit/s pentru lungimea magistralei de 3 m pentru USB 10/100 Mbit/s pentru Ethernet
<b>Protocol port de comunicare</b>	Legătură serială neizolată Modbus protocol master/slave
<b>Port Ethernet</b>	10BASE-T/100BASE-TX - 1 port(uri) cablu de cupru
<b>Ethernet services</b>	FDR DHCP server via TM4 Ethernet switch network module Client DHCP embedded Ethernet port SMS notifications Actualizare firmware

SNMP client/server  
 Programare  
 NGVL  
 Monitorizare  
 IEC VAR ACCESS  
 FTP client/server  
 Descărcare  
 SQL client  
 Modbus TCP client I/O scanner  
 Ethernet/IP originator I/O scanner embedded Ethernet port  
 Ethernet/IP target, Modbus TCP server and Modbus TCP slave  
 Send and receive email from the controller based on TCP/UDP library  
 Web server (WebVisu & XWeb system)  
 OPC UA server  
 DNS client

<b>Semnalizare locala</b>	PentruPWR 1 LED (verde) PentruRUN 1 LED (verde) Pentrueroare modul (ERR) 1 LED (rosu) PentruEroare I/O (I/O) 1 LED (rosu) PentruCard SD de acces (SD) 1 LED (verde) PentruBAT 1 LED (rosu) PentruSL1 1 LED (verde) PentruSL2 1 LED (verde) Pentrudefect magistrală la TM4 (TM4) 1 LED (rosu) Pentrustare I/O 1 LED per canal (verde) PentruActivitate port Ethernet 1 LED (verde)
<b>Conexiune electrica</b>	cutie de borne cu suruburi amovibilapentru intrări #i ie#iri (pitch 5.08 mm) cutie de borne cu suruburi amovibilapentru conectarea alimentării 24 V c.c. (pitch 5.08 mm)
<b>Distanta maxima cablu intre dispozitive</b>	Cablu neecranat <50 m pentru interior Cablu ecranat <10 m pentru intrare rapidă Cablu neecranat <50 m pentru ieşire Cablu ecranat <3 m pentru ieşire rapidă
<b>Izolatie</b>	Între alimentare #i logica internă la 500 V c.a. Neizolat între alimentare #i pământ Între intrare #i logica internă la 500 V c.a. Neizolat între intrări Între intrările rapide #i logica internă la 500 V c.a. Între ieşire #i logica internă la 500 V c.a. Neizolat între ieşiri Între ieşirile rapide #i logica internă la 500 V c.a. Între grupurile de ieşire la 500 V c.a.
<b>Marcaj</b>	CE
<b>Incercare la supratensiuni tranzitorii</b>	1 kV alimentare (c.c.) mod comun conformitate cu EN/IEC 61000-4-5 1 kV cablu ecranat mod comun conformitate cu EN/IEC 61000-4-5 0,5 kV alimentare (c.c.) mod diferențial conformitate cu EN/IEC 61000-4-5 1 kV ieşire pe releu mod diferențial conformitate cu EN/IEC 61000-4-5 1 kV intrare mod comun conformitate cu EN/IEC 61000-4-5 1 kV ieşire pe tranzistor mod comun conformitate cu EN/IEC 61000-4-5
<b>Servicii Web</b>	Server web
<b>Numar maxim de conexiuni</b>	8 Server Modbus 8 SoMachine protocol 10 server web 4 FTP server 16 Ethernet/IP target 8 Modbus client
<b>Numar de slave</b>	64 Modbus TCP 16 Ethernet/IP
<b>Timp de ciclu</b>	10 ms 16 Ethernet/IP 64 ms 64 Modbus TCP
<b>Support de montare</b>	Top hat type TH35-15 sina conformitate cu IEC 60715 Top hat type TH35-7.5 sina conformitate cu IEC 60715 placă sau panou cu kit de fixare
<b>Inaltime</b>	90 mm
<b>Adancime</b>	95 mm
<b>Latime</b>	150 mm
<b>Greutate neta</b>	0,53 kg

## Mediu

<b>Standarde</b>	ANSI/ISA 12-12-01 Standard CSA C22.2 No 142 Standard CSA C22.2 No 213 EN/IEC 61131-2:2007 Specifica#ie marină (LR, ABS, DNV, GL) UL 1604
------------------	---



<b>Certificari produs</b>	cULus IACS E11 RCM CSA
<b>Rezistenta la descarcari electrostatice</b>	8 kV în aer conformitate cu EN/IEC 61000-4-2 4 kV pe contact conformitate cu EN/IEC 61000-4-2
<b>Rezistenta la campuri electromagnetice</b>	10 V/m 80 MHz - 1 GHz conformitate cu EN/IEC 61000-4-3 3 V/m 1.4 GHz - 2 GHz conformitate cu EN/IEC 61000-4-3 1 V/m 2 GHz...3 GHz conformitate cu EN/IEC 61000-4-3
<b>Rezistenta la tranzienti rapizi</b>	2 kV conformitate cu EN/IEC 61000-4-4 (alimentare) 1 kV conformitate cu EN/IEC 61000-4-4 (linie Ethernet) 1 kV conformitate cu EN/IEC 61000-4-4 (legatura seriala) 1 kV conformitate cu EN/IEC 61000-4-4 (intrare) 1 kV conformitate cu EN/IEC 61000-4-4 (ie#ire pe tranzistor)
<b>Rezistenta la perturbatii induse de campurile de radiofrecventa</b>	10 V 0.15 - 80 MHz conformitate cu EN/IEC 61000-4-6 3 V 0.1...80 MHz conformitate cu Specifica#ie marină (LR, ABS, DNV, GL) 10 V frecven#ă fixă (2, 3, 4, 6.2, 8.2, 12.6, 16.5, 18.8, 22, 25 MHz) conformitate cu Specifica#ie marină (LR, ABS, DNV, GL)
<b>Emisii electromagnetica</b>	Emisii conduse - test level: 120...69 dBμV/m QP alimentare) la 10...150 kHz conformitate cu EN/IEC 55011 Emisii conduse - test level: 63 dBμV/m QP alimentare) la 1,5...30 MHz conformitate cu EN/IEC 55011 Emisii radiate - test level: 40 dBμV/m QP clasa A la 30...230 MHz conformitate cu EN/IEC 55011 Emisii conduse - test level: 79...63 dBμV/m QP alimentare) la 150...1500 kHz conformitate cu EN/IEC 55011 Emisii radiate - test level: 47 dBμV/m QP clasa A la 230...1000 MHz conformitate cu EN/IEC 55011
<b>Imunitate la microintreruperi</b>	10 ms
<b>Temperatura ambientala de utilizare</b>	-10...50 °C (instalare verticală) -10...55 °C (instalare orizontală)
<b>Temperatura de depozitare</b>	-25...70 °C
<b>Umiditate relativa</b>	10...95 %, fără condensare (în func#iune) 10...95 %, fără condensare (în depozitare)
<b>Grad de protectie IP</b>	IP20 cu capac de protec#ie montat
<b>Grad de poluare</b>	2
<b>Altitudine de functionare</b>	0...2000 m
<b>Altitudinea de depozitare</b>	0...3000 m
<b>Rezistenta la vibratii</b>	3.5 mm la 5...8,4 Hz pornit șină simetrică 3 gn la 8,4...150 Hz pornit șină simetrică 3.5 mm la 5...8,4 Hz pornit montare pe panou 3 gn la 8,4...150 Hz pornit montare pe panou
<b>Rezistenta la socuri</b>	15 gn pentru 11 ms

## Unitati de ambalare

<b>Unitate de masura pentru prima forma de impachetare</b>	Db
<b>Numar unitati in prima forma de impachetare</b>	1
<b>Inaltime prima forma de impachetare</b>	11,33 cm
<b>Latime prima forma de impachetare</b>	13,095 cm
<b>Lungime prima forma de impachetare</b>	18,689 cm
<b>Greutate prima forma de impachetare</b>	640,0 g
<b>Unitate de masura pentru a doua forma de impachetare</b>	Doboz
<b>Numar unitati in a doua forma de impachetare</b>	8
<b>Inaltime a doua forma de impachetare</b>	30,0 cm

Latime a doua forma de impachetare	30,0 cm
Lungime a doua forma de impachetare	40,0 cm
Greutate a doua forma de impachetare	5,801 kg

## Sustenabilitatea ofertei

Stare ofertă sustenabilă	Produs Green Premium
Regulamentul REACH	<a href="#">Declaratia REACH</a>
Directiva RoHS UE	Conformitate proactivă (Produs în afara domeniului de aplicare a EU RoHS) <a href="#">Declaratia RoHS UE</a>
Fara mercur	Da
Regulamentul RoHS China	<a href="#">Declaratia RoHS China</a>
Informatii privind scutirea de la RoHS	Da
Raport de mediu	<a href="#">Profilul ambiental al produsului</a>
Profil circularitate	<a href="#">Informatii privind sfarsitul duratei de viata</a>
WEEE	În Uniunea Europeana, produsele trebuie reciclate respectand sistemul specific de colectare a deseurilor si nu trebuie sa ajunga in pubelele de colectare a deseurilor menajere.
Fara PVC	Da

## Garanție contractuală

Garantie	18 luni
----------	---------

Dimensions

---

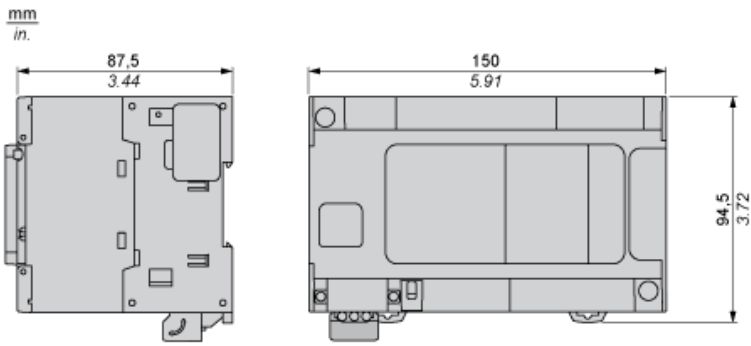



Clearance

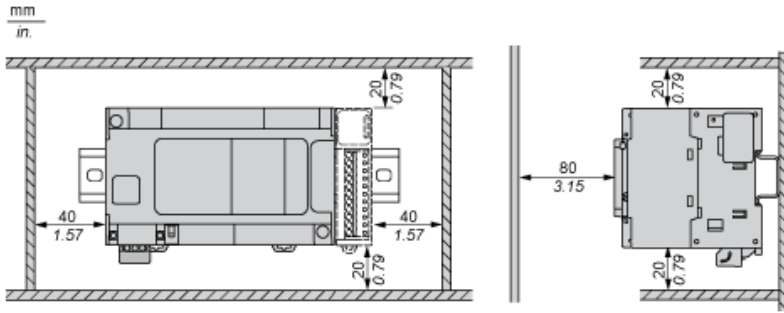

**Mounting Position**

---

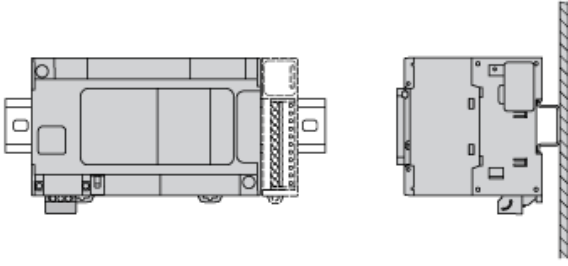

**Acceptable Mounting**

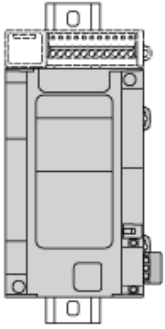

**NOTE:** Expansion modules must be mounted above the logic controller.

**Incorrect Mounting**

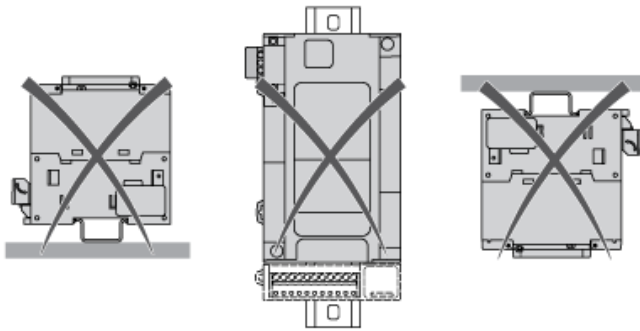

Direct Mounting On a Panel Surface

---

Mounting Hole Layout

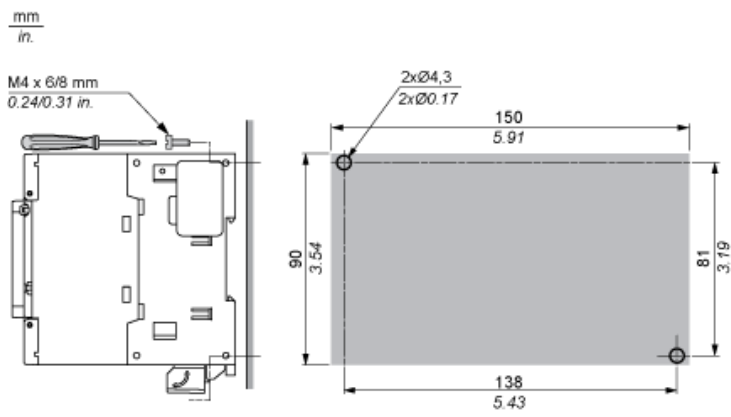



**Digital Inputs**

**Wiring Diagram**

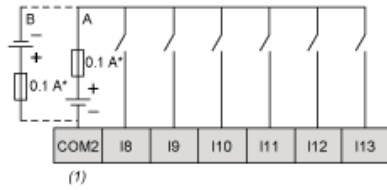
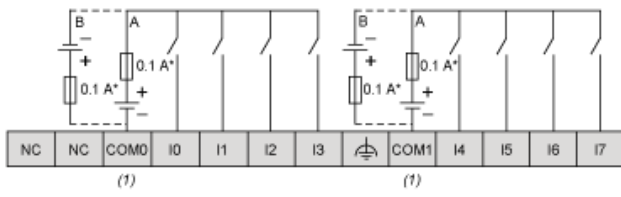

- (\*) : Type T fuse
- (1) : The COM0, COM1 and COM2 terminals are not connected internally
- (A) : Sink wiring (positive logic)
- (B) : Source wiring (negative logic)

**Fast Input Wiring (I0...I7)**

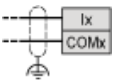

Fast Transistor Outputs

---

Wiring Diagram

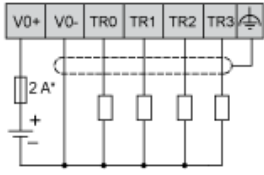

(\*) : 2 A fast-blow fuse

Transistor Outputs

---

Wiring Diagram

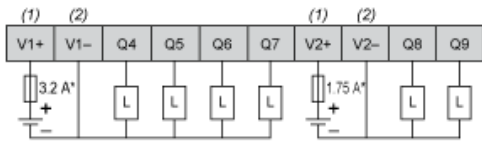

- (\*) : Type T fuse
- (1) : The V1+ and V2+ terminals are not connected internally.
- (2) : The V1- and V2- terminals are not connected internally.



**USB Mini-B Connection**

---

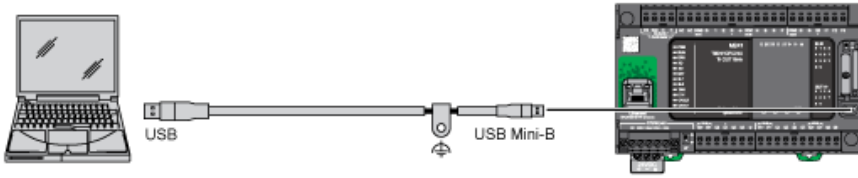

**Ethernet Connection to a PC**

---

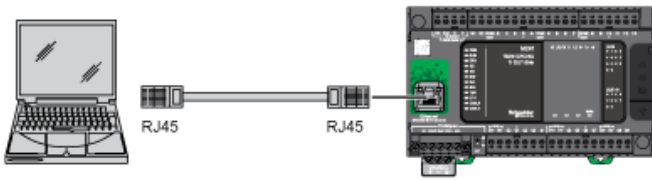

**Substitutii recomandate**



### Principal

Gama de produse	Modicon TM3
Tip produs sau componenta	Modul de intrare analogic
Compatibilitate gama	Modicon M221 Modicon M241 Modicon M251 Modicon M262
Numarul intrarii analogice	8
Tip de intrare analogica	Curent 4...20 mA Curent 0...20 mA Tensiune 0...10 V Tensiune - 10...10 V

### Suplimentar

Rezolutie de intrare analogica	12 biti 11 biti + semn
Suprasarcina continua permisa	13 V, tip de intrare analogica: tensiune 40 mA, tip de intrare analogica: curent
Impedanta de intrare	$\leq 50$ Ohm curent $\geq 1$ M $\Omega$ tensiune
Valoarea LSB	2.44 mV 0...10 V tensiune 4.88 mV - 10...10 V tensiune 4.88 $\mu$ A 0...20 mA curent 3.91 $\mu$ A 4...20 mA curent
Timp de conversie	1 ms + 1 ms per channel + 1 controller cycle time
Perioada de esantionare	1 ms
Eroare absoluta a preciziei	+/- 1 % din scală +/- 0.2 % din scală la 25 °C
Abatere a temperaturii	+/- 0.01 %FS/°C
Precizie de repetare	+/-0.5 %FS
Neliniaritate	+/- 0.2 %FS
Diafonie	$\leq 1$ LSB
[Us] tensiune de alimentare nominala	24 V c.c.
Limite tensiune de alimentare	20,4...28,8 V
Tip de cablu	Cablu ecranat cu perechi torsadate <30 m pentru interior circuit
Consum de curent	40 mA la 5 V c.c. via bus connector sarcină nominală 35 mA la 5 V c.c. via bus connector în gol 30 mA la 24 V c.c. via alimentare externă în gol 40 mA la 24 V c.c. via alimentare externă sarcină nominală
Semnalizare locala	PentruPWR 1 LED (verde)
Conexiune electrica	10 x 1.5 mm <sup>2</sup> cutie de borne cu suruburi amovibila cu pitch 3.81 mm pentru intrări <input type="checkbox"/> alimentare 10 x 1.5 mm <sup>2</sup> cutie de borne cu suruburi amovibila cu pitch 3.81 mm pentru intrări
Izolatie	Between input and supply la 1500 V c.a. Între intrare <input type="checkbox"/> i logica internă la 500 V c.a.
Marcaj	CE
Incercare la supratensiuni tranzitorii	1 KV sursa de alimentare mod comun conformitate cu EN/IEC 61000-4-5 0,5 KV sursa de alimentare mod diferențial conformitate cu EN/IEC 61000-4-5 1 kV intrare mod comun conformitate cu EN/IEC 61000-4-5
Suport de montare	Top hat type TH35-15 sina conformitate cu IEC 60715 Top hat type TH35-7.5 sina conformitate cu IEC 60715 Placă sau panou cu kit de fixare
Inaltime	90 mm
Adancime	70 mm



Latime	23,6 mm
Greutate neta	0,11 kg



## Mediu

Standarde	EN/IEC 61131-2 EN/IEC 61010-2-201
Rezistenta la descarcari electrostatice	8 KV în aer conformitate cu EN/IEC 61000-4-2 4 kV pe contact conformitate cu EN/IEC 61000-4-2
Rezistenta la campuri electromagnetice	10 V/M 80 MHz - 1 GHz conformitate cu EN/IEC 61000-4-3 3 V/M 1.4 GHz - 2 GHz conformitate cu EN/IEC 61000-4-3 1 V/m 2 GHz...3 GHz conformitate cu EN/IEC 61000-4-3
Rezistenta la campuri magnetice	30 A/m conformitate cu EN/IEC 61000-4-8
Rezistenta la tranzienti rapizi	1 kV conformitate cu EN/IEC 61000-4-4 (I/O)
Rezistenta la perturbatii induse de campurile de radiofrecventa	10 V 0.15 - 80 MHz conformitate cu EN/IEC 61000-4-6 3 V frecvență fixă (2, 3, 4, 6.2, 8.2, 12.6, 16.5, 18.8, 22, 25 MHz) conformitate cu Specificație marină (LR, ABS, DNV, GL)
Emisie electromagnetica	Emisii radiate - test level: 40 dBμV/m QP clasa A 10 m) la 30...230 MHz conformitate cu EN/IEC 55011 Emisii radiate - test level: 47 dBμV/m QP clasa A 10 m) la 230...1000 MHz conformitate cu EN/IEC 55011
Imunitate la microintreruperi	10 ms
Temperatura ambientala de utilizare	-10...55 °C instalare orizontală -10...35 °C instalare verticală
Temperatura de depozitare	-25...70 °C
Umiditate relativa	10...95 %, fără condensare (în funcțiune) 10...95 %, fără condensare (în depozitare)
Grad de protectie IP	IP20
Grad de poluare	2
Altitudine de functionare	0...2000 m
Altitudinea de depozitare	0...3000 m
Rezistenta la vibratii	3.5 mm la 5...8,4 Hz pornit sina DIN 3 gn la 8,4...150 Hz pornit sina DIN
Rezistenta la socuri	15 gn pentru 11 ms

## Unitati de ambalare

Unitate de masura pentru prima forma de impachetare	PCE
Numar unitati in prima forma de impachetare	1
Inaltime prima forma de impachetare	7,368 cm
Latime prima forma de impachetare	10,513 cm
Lungime prima forma de impachetare	12,603 cm
Greutate prima forma de impachetare	216,5 g
Unitate de masura pentru a doua forma de impachetare	S04
Numar unitati in a doua forma de impachetare	42
Inaltime a doua forma de impachetare	30,0 cm
Latime a doua forma de impachetare	40,0 cm
Lungime a doua forma de impachetare	60,0 cm
Greutate a doua forma de impachetare	10,0 kg

## Sustenabilitatea ofertei

Stare ofertă sustenabilă	Produs Green Premium
Regulamentul REACH	 <a href="#">Declaratia REACH</a>
Directiva RoHS UE	Conformitate proactivă (Produs în afara domeniului de aplicare a EU RoHS)  <a href="#">Declaratia RoHS UE</a>
Fara metale grele toxice	Da
Fara mercur	Da
Regulamentul RoHS China	 <a href="#">Declaratia RoHS China</a>

Informatii privind scutirea de la RoHS	<a href="#">Da</a>
Raport de mediu	<a href="#">Profilul Ambiental Al Produsului</a>
Profil circularitate	<a href="#">Informatii Privind Sfarsitul Duratei De Viata</a>
WEEE	În Uniunea Europeana, produsele trebuie reciclate respectand sistemul specific de colectare a deseurilor si nu trebuie sa ajunga in pubelele de colectare a deseurilor menajere.
Fara PVC	Da

### Garanție contractuală

Garantie	18 luni
----------	---------

Dimensions

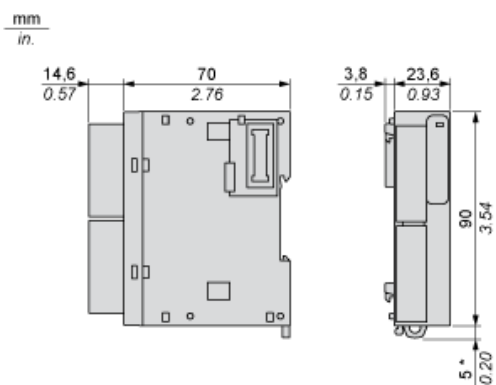

(\*) 8.5 mm/0.33 in when the clamp is pulled out.



Spacing Requirements

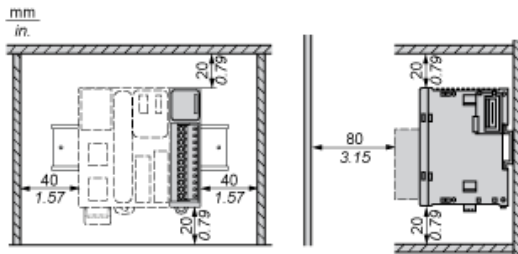

Mounting on a Rail

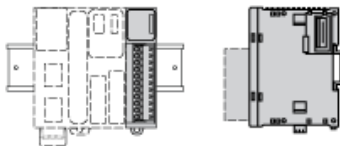

Incorrect Mounting

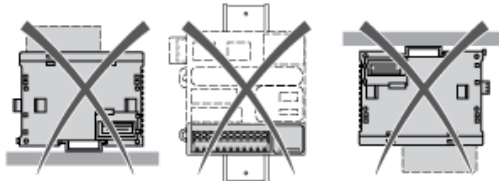

Mounting on a Panel Surface

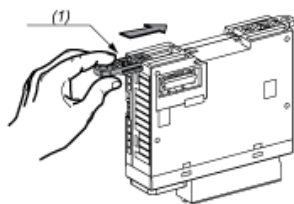

- (1) Install a mounting strip

Mounting Hole Layout

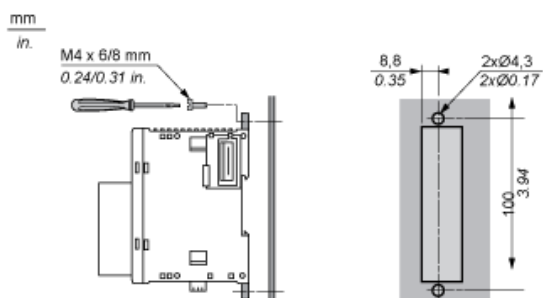

Analogue Input Module

Wiring Diagram (Current / Voltage)

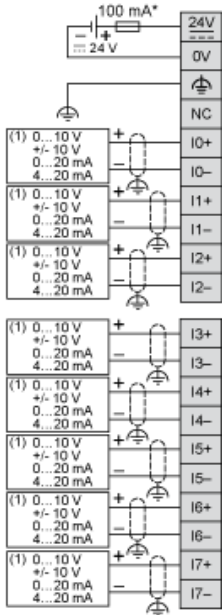

- (\*) Type T fuse
- (1) Current/Voltage analog output device

# Fișă tehnică produs

Specificatii



## Module TM3, 4 Iesiri Analogice

TM3AQ4

### Principal

Gama de produse	Modicon TM3
Tip produs sau componenta	Modul de iesire analogic
Compatibilitate gama	Modicon M221 Modicon M241 Modicon M251 Modicon M262
Numarul iesirii analogice	4
Tip iesire analogica	Curent 4...20 mA Curent 0...20 mA Tensiune 0...10 V Tensiune - 10...10 V

### Suplimentar

Rezolutie de intrare analogica	12 biti 11 biti + semn
Rezolutie de iesire analogica	11 biti + semn 12 biti
Valoarea LSB	2.44 mV 0...10 V tensiune 4.88 mV - 10...10 V tensiune 4.88 $\mu$ A 0...20 mA curent 3.91 $\mu$ A 4...20 mA curent
Tip sarcina	Rezistiv
Impedanta ohmica a sarcinii	1 kOhm tensiune 300 Ohm curent
Timp de stabilizare	1 ms
Timp de conversie	1 ms + 1 ms per channel + 1 controller cycle time
Eroare absoluta a preciziei	+/- 1 % din scală +/- 0.2 % din scală at 25 °C
Abatere a temperaturii	+/- 0.01 %FS/°C
Precizie de repetare	+/- 0.4 %FS
Neliniaritate	+/- 0.2 %FS
Pulsatie de iesire	20 mV
Diafonie	$\leq$ 1 LSB
[Us] tensiune de alimentare nominala	24 V c.c.
Limite tensiune de alimentare	20,4...28,8 V
Tip de cablu	Cablu ecranat cu perechi torsadate <30 m pentru ieșire circuit

<b>Consum de curent</b>	40 mA la 5 V c.c. via bus connector în gol 50 mA la 5 V c.c. via bus connector sarcină nominală 50 mA la 24 V c.c. via alimentare externă în gol 125 mA la 24 V c.c. via alimentare externă sarcină nominală
<b>Semnalizare locala</b>	Pentru PWR 1 LED (verde)
<b>Conexiune electrica</b>	11 x 2.5 mm <sup>2</sup> cutie de borne cu suruburi amovibile cu pitch 5.08 mm pentru ieșiri #i alimentare
<b>Izolatie</b>	Between output and supply la 1500 V c.a. Între ieșire #i logica internă la 500 V c.a.
<b>Marcaj</b>	CE
<b>Incercare la supratensiuni tranzitorii</b>	1 kV sursa de alimentare mod comun conformitate cu EN/IEC 61000-4-5 0,5 kV sursa de alimentare mod diferențial conformitate cu EN/IEC 61000-4-5 1 kV output mod comun conformitate cu EN/IEC 61000-4-5
<b>Suport de montare</b>	Top hat type TH35-15 sına conformitate cu IEC 60715 Top hat type TH35-7.5 sına conformitate cu IEC 60715 placă sau panou cu kit de fixare
<b>Inaltime</b>	90 mm
<b>Adancime</b>	70 mm
<b>Latime</b>	23,6 mm
<b>Greutate neta</b>	0,115 kg

## Mediu

<b>Standarde</b>	EN/IEC 61010-2-201 EN/IEC 61131-2
<b>Rezistenta la descarcari electrostatice</b>	8 kV în aer conformitate cu EN/IEC 61000-4-2 4 kV pe contact conformitate cu EN/IEC 61000-4-2
<b>Rezistenta la campuri electromagnetice</b>	10 V/m 80 MHz - 1 GHz conformitate cu EN/IEC 61000-4-3 3 V/m 1.4 GHz - 2 GHz conformitate cu EN/IEC 61000-4-3 1 V/m 2 GHz...3 GHz conformitate cu EN/IEC 61000-4-3
<b>Rezistenta la campuri magnetice</b>	30 A/m conformitate cu EN/IEC 61000-4-8
<b>Rezistenta la tranzienti rapizi</b>	1 kV conformitate cu EN/IEC 61000-4-4 (I/O)
<b>Rezistenta la perturbatii induse de campurile de radiofrecventa</b>	10 V 0.15 - 80 MHz conformitate cu EN/IEC 61000-4-6 3 V frecvență fixă (2, 3, 4, 6.2, 8.2, 12.6, 16.5, 18.8, 22, 25 MHz) conformitate cu Specificație marină (LR, ABS, DNV, GL)
<b>Emisie electromagnetica</b>	Emisii radiate - test level: 40 dBμV/m QP clasa A 10 m) la 30...230 MHz conformitate cu EN/IEC 55011 Emisii radiate - test level: 47 dBμV/m QP clasa A 10 m) la 230...1000 MHz conformitate cu EN/IEC 55011
<b>Imunitate la microintreruperi</b>	10 ms
<b>Temperatura ambientala de utilizare</b>	-10...55 °C instalare orizontala -10...35 °C instalare verticala
<b>Temperatura de depozitare</b>	-25...70 °C
<b>Umiditate relativa</b>	10...95 %, fără condensare (în funcție)
	10...95 %, fără condensare (în depozitare)
<b>Grad de protectie IP</b>	IP20
<b>Grad de poluare</b>	2
<b>Altitudine de functionare</b>	0...2000 m
<b>Altitudinea de depozitare</b>	0...3000 m
<b>Rezistenta la vibratii</b>	3.5 mm la 5...8,4 Hz pornit sına DIN 3 gn la 8,4...150 Hz pornit sına DIN
<b>Rezistenta la socuri</b>	15 gn pentru 11 ms

## Unitati de ambalare

<b>Unitate de masura pentru prima forma de impachetare</b>	Db
--	----



Numar unitati in prima forma de impachetare	1
Inaltime prima forma de impachetare	7,422 cm
Latime prima forma de impachetare	10,612 cm
Lungime prima forma de impachetare	12,908 cm
Greutate prima forma de impachetare	220,0 g
Unitate de masura pentru a doua forma de impachetare	S04
Numar unitati in a doua forma de impachetare	42
Inaltime a doua forma de impachetare	30,0 cm
Latime a doua forma de impachetare	40,0 cm
Lungime a doua forma de impachetare	60,0 cm
Greutate a doua forma de impachetare	10,25 kg

## Sustenabilitatea ofertei

Stare ofertă sustenabilă	Produs Green Premium
Regulamentul REACH	<a href="#">Declaratia REACH</a>
Directiva RoHS UE	Conformitate proactivă (Produs în afara domeniului de aplicare a EU RoHS) <a href="#">Declaratia RoHS UE</a>
Fara metale grele toxice	Da
Fara mercur	Da
Regulamentul RoHS China	<a href="#">Declaratia RoHS China</a>
Informatii privind scutirea de la RoHS	Da
Raport de mediu	<a href="#">Profilul ambiental al produsului</a>
Profil circularitate	<a href="#">Informatii privind sfarsitul duratei de viata</a>
WEEE	În Uniunea Europeana, produsele trebuie reciclate respectand sistemul specific de colectare a deseurilor si nu trebuie sa ajunga in pubelele de colectare a deseurilor menajere.
Fara PVC	Da

## Garanție contractuală

Garantie	18 luni
----------	---------

Dimensions

---

mm  
in.

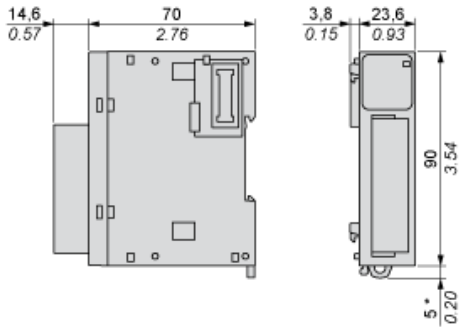

(\*) 8.5 mm/0.33 in when the clamp is pulled out.

Spacing Requirements

---

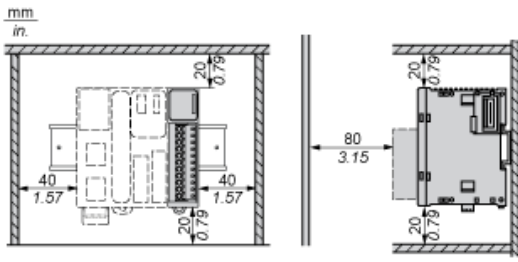

**Mounting on a Rail**

---

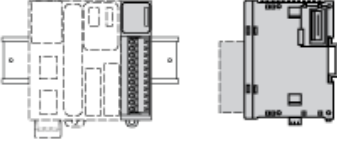

**Incorrect Mounting**

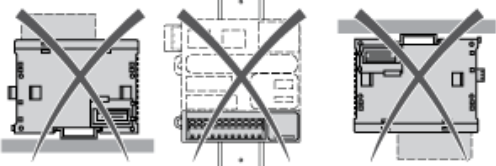



**Mounting on a Panel Surface**

---

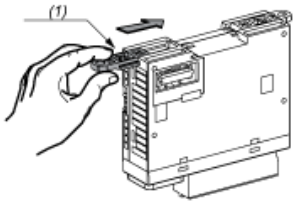

(1) Install a mounting strip

**Mounting Hole Layout**

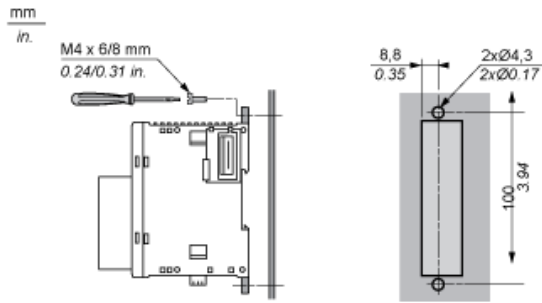

**Analogue Output Module**

---

**Wiring Diagram (Current / Voltage)**

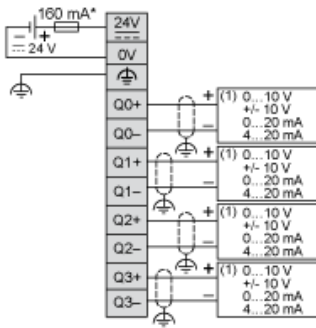

- (\*) Type T fuse
- (1) Voltage/current pre-actuator

**Substituii recomandate**

# Fișă tehnică produs

Specificatii



## Module TM3, 24 Io Relee

TM3DM24R

### Principal

Gama de produse	Modicon TM3
Tip produs sau componenta	Modul I/O discret
Compatibilitate gama	Modicon M241 Modicon M251 Modicon M221 Modicon M262
Număr intrare discretă	16 pentru interior conformitate cu IEC 61131-2 Tip 1
Logica de intrare discreta	Sink sau source (logică pozitivă/negativă)
Tensiune de intrare discreta	24 V
Curent intrare discreta	7 mA pentru interior
Tip de iesire discreta	Releu normal deschis
Numar iesire discreta	8
Logica de iesire discreta	Pozitiv sau negativ
Tensiune iesire discreta	24 V c.c. pentru ieșire releu 240 V c.a. pentru ieșire releu
Curent iesire discreta	2000 mA pentru ieșire releu

### Suplimentar

Numarul I/O discrete	24
Consum de curent	5 mA la 5 V c.c. via bus connector (at state off) 0 mA la 24 V c.c. via bus connector (în starea pornit) 0 mA la 24 V c.c. via bus connector (at state off) 65 mA la 5 V c.c. via bus connector (în starea pornit)
Tip tensiune de intrare discreta	C.c.
Starea 1 garantata a tensiunii	15...28.8 V pentru interior
Stare curenta 1 garantata	$\geq 2.5$ mA (interior)
Starea 0 garantata a tensiunii	0...5 V pentru interior
Stare curenta 0 garantata	$\leq 1$ mA (interior)
Impedanta de intrare	3.4 kOhm
Timp de raspuns	4 ms (pornit) 4 ms (oprit)
Curent maxim pe iesire comuna	7 A
Durabilitate mecanica	20000000 cic

<b>Sarcina minima</b>	10 mA la 5 V c.c. pentru ieșire releu
<b>Semnalizare locala</b>	Pentrustare I/O 1 LED per canal (verde)
<b>Conexiune electrica</b>	17 x 1.5 mm <sup>2</sup> cutie de borne cu suruburi amovibila cu pitch 3.81 mm pentru intrări 11 x 1.5 mm <sup>2</sup> cutie de borne cu suruburi amovibila cu pitch 3.81 mm pentru ieșiri
<b>Distanța maxima cablu între dispozitive</b>	Cablu neecranat <30 m pentru regular input
<b>Izolatie</b>	Între intrare #i logica internă la 500 V c.a. Neizolat între intrări Between input groups and output groups la 1500 V c.a. Between open contact la 750 V c.a. Între ieșire #i logica internă la 500 V c.a. Neizolat între ieșiri
<b>Marcaj</b>	CE
<b>Suport de montare</b>	Top hat type TH35-15 sina conformitate cu IEC 60715 Top hat type TH35-7.5 sina conformitate cu IEC 60715 placă sau panou cu kit de fixare
<b>Inaltime</b>	90 mm
<b>Adancime</b>	84,6 mm
<b>Latime</b>	42,9 mm
<b>Mediu</b>	
<b>Standarde</b>	EN/IEC 61131-2 EN/IEC 61010-2-201
<b>Certificari produs</b>	cULus C-Tick
<b>Rezistenta la descarcari electrostatice</b>	8 kV în aer conformitate cu EN/IEC 61000-4-2 4 kV pe contact conformitate cu EN/IEC 61000-4-2
<b>Rezistenta la campuri electromagnetice</b>	10 V/m 80 MHz - 1 GHz conformitate cu EN/IEC 61000-4-3 3 V/m 1.4 GHz - 2 GHz conformitate cu EN/IEC 61000-4-3 1 V/m 2 GHz...3 GHz conformitate cu EN/IEC 61000-4-3
<b>Rezistenta la campuri magnetice</b>	30 A/m 50/60 Hz conformitate cu EN/IEC 61000-4-8
<b>Rezistenta la tranzienti rapizi</b>	1 kV pentru I/O conformitate cu EN/IEC 61000-4-4 2 kV pentru ieșire pe releu conformitate cu EN/IEC 61000-4-4
<b>Incercare la supratensiuni tranzitorii</b>	2 kV output mod comun conformitate cu EN/IEC 61000-4-5 1 kV intrare mod comun conformitate cu EN/IEC 61000-4-5
<b>Rezistenta la perturbatii induse de campurile de radiofrecventa</b>	10 V 0.15 - 80 MHz conformitate cu EN/IEC 61000-4-6 3 V frecvență fixă (2, 3, 4, 6.2, 8.2, 12.6, 16.5, 18.8, 22, 25 MHz) conformitate cu Specificație marină (LR, ABS, DNV, GL)
<b>Emisie electromagnetica</b>	Emisii radiate - test level: 40 dBμV/m QP clasa A 10 m) la 30...230 MHz conformitate cu EN/IEC 55011 Emisii radiate - test level: 47 dBμV/m QP clasa A 10 m) la 230...1000 MHz conformitate cu EN/IEC 55011
<b>Temperatura ambientala de utilizare</b>	-10...35 °C instalare verticală -10...55 °C instalare orizontală
<b>Temperatura de depozitare</b>	-25...70 °C
<b>Umiditate relativa</b>	10...95 %, fără condensare (în funcțiune) 10...95 %, fără condensare (în depozitare)
<b>Grad de protectie IP</b>	IP20 cu capac de protecție montat
<b>Grad de poluare</b>	2
<b>Altitudine de functionare</b>	0...2000 m
<b>Altitudinea de depozitare</b>	0...3000 m
<b>Rezistenta la vibratii</b>	3.5 mm la 5...8,4 Hz pornit sina DIN 3 gn la 8,4...150 Hz pornit sina DIN 3.5 mm la 5...8,4 Hz pornit panou 3 gn la 8,4...150 Hz pornit panou
<b>Rezistenta la socuri</b>	15 gn pentru 11 ms



## Unitati de ambalare

Unitate de masura pentru prima forma de impachetare	Db
Numar unitati in prima forma de impachetare	1
Inaltime prima forma de impachetare	7,551 cm
Latime prima forma de impachetare	10,686 cm
Lungime prima forma de impachetare	12,849 cm
Greutate prima forma de impachetare	281,0 g
Unitate de masura pentru a doua forma de impachetare	CAR
Numar unitati in a doua forma de impachetare	42
Inaltime a doua forma de impachetare	30,6 cm
Latime a doua forma de impachetare	40,1 cm
Lungime a doua forma de impachetare	57,6 cm
Greutate a doua forma de impachetare	12,61 kg

## Sustenabilitatea ofertei

Stare ofertă sustenabilă	Produs Green Premium
Regulamentul REACH	<a href="#">Declaratia REACH</a>
Conform REACH fara SVHC	Da
Directiva RoHS UE	Conformitate proactivă (Produs în afara domeniului de aplicare a EU RoHS) <a href="#">Declaratia RoHS UE</a>
Fara metale grele toxice	Da
Fara mercur	Da
Regulamentul RoHS China	<a href="#">Declaratia RoHS China</a>
Informatii privind scutirea de la RoHS	Da
Raport de mediu	<a href="#">Profilul ambiental al produsului</a>
Profil circularitate	<a href="#">Informatii privind sfarsitul duratei de viata</a>
WEEE	În Uniunea Europeana, produsele trebuie reciclate respectand sistemul specific de colectare a deseurilor si nu trebuie sa ajunga in pubelele de colectare a deseurilor menajere.
Fara PVC	Da

## Garanție contractuală

Garantie	18 luni
----------	---------

Dimensions

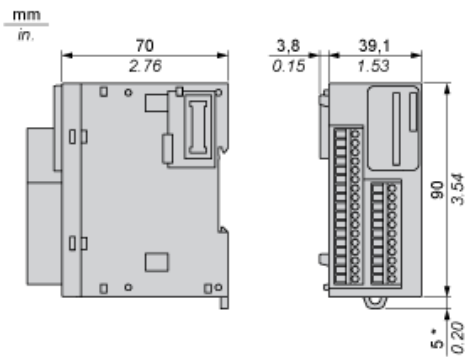

(\*) 8.5 mm/0.33 in. when the clamp is pulled out.

Spacing Requirements

---

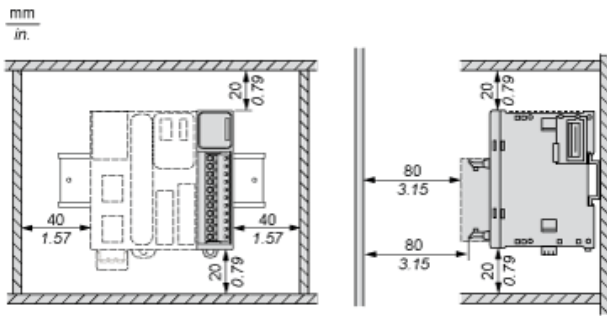

**Mounting on a Rail**

---

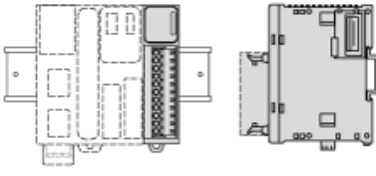

**Incorrect Mounting**

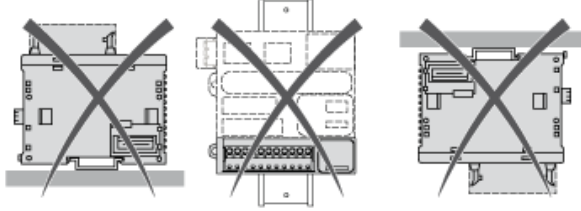



**Mounting on a Panel Surface**

---

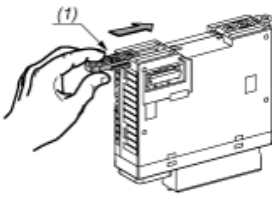

(1) Install a mounting strip

**Mounting Hole Layout**

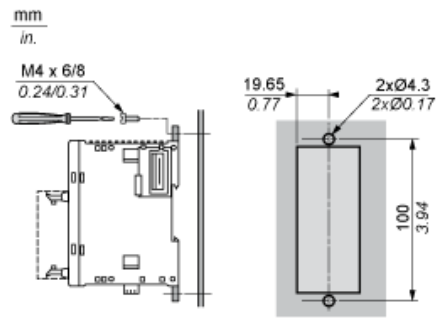

Digital Mixed I/O Module (24-channel)

Wiring Diagram (Source)

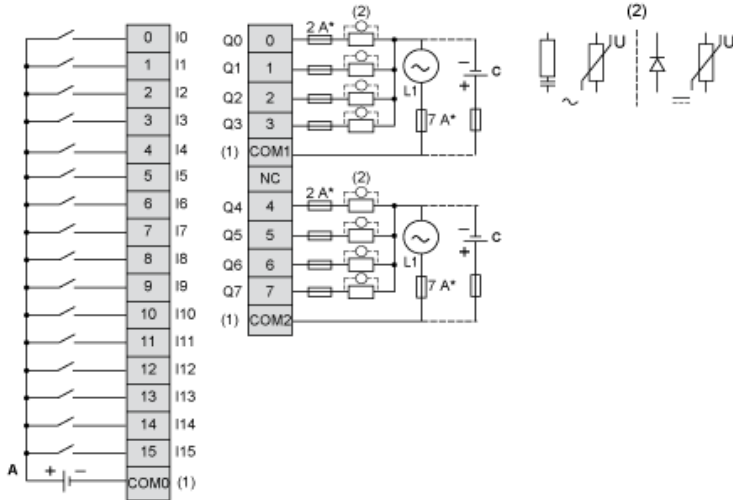

- (\*) Type T fuse
- (1) The COM0, COM1 and COM2 terminals are **not** connected internally.
- (2) To improve the life time of the contacts, and to protect from potential inductive load damage, it is recommended to connect a free wheeling diode
- (A) Sink wiring (positive logic)
- (C) Source wiring (positive logic)

Wiring Diagram (Sink)

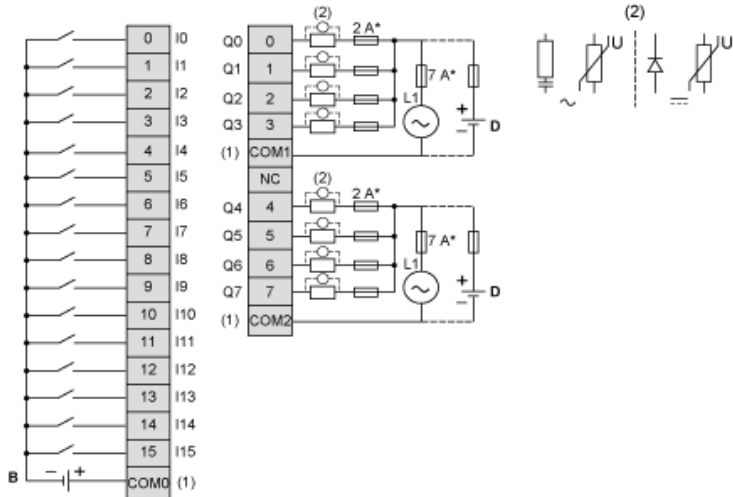

- (\*) Type T fuse
- (1) The COM0, COM1 and COM2 terminals are **not** connected internally.
- (2) To improve the life time of the contacts, and to protect from potential inductive load damage, it is recommended to connect a free wheeling diode
- (B) Source wiring (negative logic)
- (D) Sink wiring (negative logic)

Substituii recomandate

## ®IEPE Premium Accelerometer, Top Connector

### Main Characteristics

- Atex Approved for zone 0, 1, 22, 21, 22
- Piezoelectric annular shear mode  
(better than obsolete compression design / Shear Plane)
- 10, 50, 100, 250, 500, 1000 mV/g version available
- -54°C to 121 °C (-67°F to 250°F)
- Dual case isolation with Faraday shield
- Submersible version (150 metres).
- life time hermetic sealing warranty (M12/Mil glass seal connector)

### Competitive advantage

- Compare to obsolete compression design, annular shear piezoelectric sensors feature better frequency response, improved base strain, lower noise, smaller size, thermal transient immunity and insensitivity to cable motion. Annular shear mode is also less susceptible to transverse vibrations and better immune to electronic saturation at high frequency.
- Improved dynamic range (thanks to exceptional bias stability) at elevated temperatures.
- Resistant to shock (magnet mounting) thanks to Jfet transistor input.
- ESD and reverse wiring protection.
- The glass seal hermetic connector protects the piezoelectric disc and the electronic from harmful environmental influences, significantly increasing their reliability and lifetime. Sensors with epoxy seal will always leak after few temperature cycles.
- M12 connector offers compatibility with numerous sensors used in automation. M12 overmolded cable assemblies are available from many cable manufacturers around the world. Mil cordset are expensive because they are only available from vibration sensor manufacturers.

### Description

The hermetic sealed industrial piezoelectric accelerometer model 101 is designed to monitor the vibration in harsh industrial environment. It uses the industry standard ©ICP / ©IEPE / ©LIVM 2-wire voltage transmission technique with a 4 mA standard constant current supply. Signal ground is isolated from the mounting surface and outer case to prevent ground loops. Faraday shielding will limit sensitivity to EMC to a minimum. Annular shear mode design will prevent from thermal transient and from spurious signal from high transverse vibrations. Low noise electronic and a temperature compensated design will give you accurate result over the complete temperature range. Large choice of frequency range will help to fit almost every customer requirements. Low frequency accelerometers (A=9, 0) incorporate a low-pass filter within the conditioning electronic. This filter attenuates the sensor mechanical resonance and the associated distortion and overload.



Model 101.51-AA-2

### Typical applications

Vibrations measurement in the rugged environments of industrial machinery monitoring. High frequency version monitor the vibration on roller bearing, pumps cavitation, ... Medium frequency version monitor overall vibration on pumps, motors, fans, ... Low frequency model is used in the petrochemical, machine tool, and paper industries for monitoring of slow speed agitators, cooling towers, ... High temperature version is typically used where extra temperature protection is needed, such as the dryer section of a paper machine.

### Approvals



### Revision History

- May 2003 : Released
- Dec 2014 : electronic upgrade
- Sept 2016 : improved case electrical isolation

## Ordering information

To order, specify model number, options, accessories and suffix :

**101.51- AA - B - TT - HH - YY**

### AA : Sensitivity

3	.....	10 mV/g ± 5 %
3D	.....	10 mV/g ± 10 %
5	.....	50 mV/g ± 5 %
5D	.....	50 mV/g ± 10 %
6	.....	100 mV/g ± 5 %
6D	.....	100 mV/g ± 10 %
7	.....	250 mV/g ± 5 %
7D	.....	250 mV/g ± 10 %
8	.....	250 mV/g ± 5 %
8D	.....	250 mV/g ± 10 %
9	.....	500 mV/g ± 5 %
9D	.....	500 mV/g ± 10 %
0	.....	1000 mV/g ± 5 %
0D	.....	1000 mV/g ± 10 %

Note: 7, 9, 0 High pass frequency = 0.2 Hz.

Available suffix : N, negative polarity

### B : Connector

1	.....	MIL-C-5015, glass seal, Type MS3143 10SL-4P
2	.....	M12 glass seal, IEC 60947-5-2

### B (CC-DD) : Integral Cable

5(01-DD)	.....	90°C Polyurethane cable
5(02-DD)	.....	200°C Teflon FEP cable
5(03-DD)	.....	120°C Radox Halogen Free cable
5(31-DD)	.....	90°C Polyurethane cable with Temperature output
5(12-DD)	.....	200°C Teflon FEP cable with Temperature output
5(13-DD)	.....	120°C Radox Halogen Free cable with Temperature output
7(01-DD)	.....	90°C Polyurethane cable with sssl overbraid protection
7(02-DD)	.....	200°C Teflon FEP cable with sssl overbraid protection
7(03-DD)	.....	120°C Radox Halogen Free cable with sssl overbraid protection
7(12-DD)	.....	200°C Teflon FEP cable with sssl overbraid & Temp. output
7(13-DD)	.....	120°C Radox Halogen Free cable with sssl overbraid & Temp. output
8(01-DD)	.....	90°C Polyurethane cable with stainless steel protection conduit
8(02-DD)	.....	200°C Teflon FEP cable with stainless steel protection conduit
8(03-DD)	.....	120°C Radox Halogen Free cable with sssl protection conduit
8(31-DD)	.....	90°C PU cable with sssl protection conduit & Temp. output
8(12-DD)	.....	200°C Teflon FEP cable with sssl protection conduit & Temp. output
8(13-DD)	.....	120°C Radox cable with sssl protection conduit & Temp. output

DD length in metres. Standard lengths are 2m, 5m, 10m, 15m, 20m, 30m.

### TT : Temperature output. (Not available with Mil-C-5015 2 pins connector)

Omitted	.....	no temperature output
T0	.....	10 mV/°C. (range +2° to +120°C)

### HH : Housing thread

Omitted	.....	M6x1
H7	.....	1/4" 28 UNF-2A



H8 ..... M8x1.25

**YY : Explosion proof Agency Approval**

Omitted ..... no specific agency approval

Y1 (Atex & IECEX) ..... Suitable for Zone 0, 1, 20, 21, 22  
 Group Category Gaz - Protection ..... II 1 G - Ex ia IIC T4 Ga  
 Group Category Dusts - Protection ... II 1 D - Ex ia IIIC T135°C Da  
 Group Mine - Protection ..... I M1 - Ex ia I Ma  
 AA can be ..... 3, 3D, 5, 5D, 6, 6D, 7, 7D, 8, 8D, 9, 9D, 0, 0D  
 B can be ..... 1, 2  
 B(CC,DD) can be ..... 5(03-DD), 7(02-DD), 7(03-DD)  
 ..... 8(02-DD), 8(03-DD)  
 & DD ≤ 99  
 TT can be ..... Omitted  
 HH can be ..... Omitted or H7

Valid in South Korea (Connector Version) ..... 19-KA4BO-0551X  
 Valid in South Korea (Cable Version) ..... 19-KA4BO-0552X

Y5 (CSA Approval)..... Not Released  
 IS Class 1, Division 1, Groups A to D  
 Ex ia IIC / Class I, Zone 0 AEx ia IIC T4  
 AA Options can be ..... Same as Y1 (Atex)

**OEM or Customer Engraving :**

Add ZXX at the end of the part number.  
 XX is a number supplied by VibraSens.  
 Customer Engraving is not allowed for Explosion proof sensor.  
 OEM should contact VibraSens if custom Engraving for Explosion proof sensor is needed.

**In stock Model**

**Metric connector**

101.51-6D-2 ..... 100 mV/g ±10% general purpose version  
 101.51-6-2 ..... 100 mV/g ±5 %, general purpose version  
 101.51-9-2 ..... 500 mV/g ±5 %, low frequency version  
 101.51-3-2 ..... 10 mV/g ±5 %, high frequency version  
 101.51-6D-2-T0 ..... 100 mV/g ±10 %with temperature output

**American/UK connector**

101.51-6D-1-H7 ..... 100 mV/g±10% (1/4”28UNF housing thread)  
 101.11-6-1-H7 ..... 100 mV/g±5 % high temp. version (150°C)  
 101.51-9-1-H7 ..... 500 mV/g±5 % low frequency version  
 101.51-3-1-H7 ..... 10 mV/g 5 % high frequency version

**Available Model with short lead time (1 week)**

101.51-6D-5(01-Length) ..... integral polyurethane cable  
 101.51-6D-7(02-Length) ..... integral 200°C sssl overbraided teflon cable

**Obsolete Part number compatibility**

101.21-6 is replaced by 101.51-6D  
 B=3 : M12 epoxy seal connector is obsolete. B=2 should be ordered.

**Ordering example :**

101.51-6D-2: Premium accelerometer, 100mV/g, M12 glass seal connector  
 101.51-6D-7(02-05): Premium accelerometer, 5 metres Integral teflon cable with Stainless steel overbraid.

**Configurations**



**M12 glass seal  
(B = 2)**

Pin 1 : not connected  
Pin 2 : not connected or temperature output (T0 option)  
Pin 3 : (-)  
Pin 4 : (+)

Associated cable  
10.01-A01-E02-31-Length  
Black (+); Blue (-)  
Temperature Output (T0 option) between Blue (-) and White (+)

**Mil-C-5015  
(B = 1)**

Pin A : (+)  
Pin B : (-)

Associated cable  
10.01-A01-B22-06-Length:  
Red (+); White (-)  
Associated cable  
10.01-A01-B22-02-Length:  
Red (+); White (-)  
Note: No temperature option available

**Integral Cable  
B = 5 (CC-DD)**

CC=01, 02 (PU, Teflon) :  
White (-); Red (+)

CC=03 (Radox) : White  
N°1 (-); White N°2 (+)

CC=12 (Teflon): White  
(-) ; Red (+)  
Temperature output  
between Black and  
White

CC=13 (Radox) : White  
N°1 (-); White N°2 (+)  
Temperature output  
between White N°3 and  
White N°1

CC=31 (PU) : Blue(-);  
Black(+); Brown (NC)  
Temperature output  
between White(+) and  
Blue (-)

NC: Not connected; (1)  
with T0 option

**Integral cable with  
overbraid  
B = 7 (CC-DD)**

Same wiring color as  
B=5

**Integral cable with  
protection conduit  
B = 8 (CC-DD)**

Same wiring color as  
B=5

## Specifications (24°C)

### Dynamic

Frequency response (Typical curve). See Fig. 1. & 2. .	
A=3X (10mV/g)	±10 % : 1 to 10000 Hz ±3 dB : 0.5 to 16000 Hz
A=6X (100 mV/g)	±10 % : 1 to 9000 Hz ±3 dB : 0.5 to 14000 Hz
A=9X (500 mV/g)	±10 % : 0.4 to 1600 Hz ±3 dB : 0.2 to 3700 Hz
A=0X (1000 mV/g)	±10 % : 0.4 to 1600 Hz ±3 dB : 0.2 to 3700 Hz
Mounted Resonant frequency	
A=3X (10 mV/g)	35 kHz Nom.
A=5X, 6X (50, 100 mV/g)	25 kHz Nom.
A=9X, 0X (500, 1000 mV/g)	16 kHz Nom.
Dynamic range	
A=3X (10 mV/g)	800 g pk.
A=5X (50 mV/g)	160 g pk.
A=6X (100 mV/g)	80 g pk
A=9X (500 mV/g)	16 g pk
A=0X (1000 mV/g)	8 g pk
Transverse response sensitivity (20Hz, 5g)	<.5%
Temperature response	see fig3
Linearity	±1% Max
Warm up time	
A=3X, 5X, 6X (10, 50, 100 mV/g)	< 1Sec
A=9X, 0X (500, 1000 mV/g)	< 10 Sec
Temperature Output (Option T0)	
	Only available if sensor is powered via IEPE
	Output (between - and Temp)
	0VDC at 0°C
	Vout=10mV/°C * Temp.(°C)
	Range: +2° to 120°C

### Electrical

Electrical Grounding	Isolated from machine ground Internal Faraday shielding
Isolation(Case to shield)	100 MΩ Min
Capacitance to ground	70 pF Nom
Output impedance	50 Ω Nom
DC output bias, 4mA supply (AA=3X, 5X, 6X)	12 VDC Nom
DC output Bias, 4 mA supply (AA=9X, 0X)	10 VDC Nom
Residual noise (24°C) : A=3X (10 mV/g)	
1 Hz	200 ug /√ Hz
10 Hz	30 ug /√ Hz
100 Hz	10 ug /√ Hz
1000 Hz	10 ug /√ Hz
Residual noise (24°C) : A=6X (100 mV/g)	
1 Hz	30 ug /√ Hz

10 Hz	6 ug /√ Hz
100 Hz	5 ug /√ Hz
1000 Hz	5 ug /√ Hz
Residual noise (24°C) : A=9X (500 mV/g)	
0.1 Hz	20 ug /√ Hz
1 Hz	6 ug /√ Hz
10 Hz	2 ug /√ Hz
100 Hz	2 ug /√ Hz
1000 Hz	2 ug /√ Hz
Residual noise (24°C) : A=0X (1000 mV/g)	
0.1 Hz	20 ug /√ Hz
1 Hz	5 ug /√ Hz
10 Hz	1 ug /√ Hz
100 Hz	0.5 ug /√ Hz
1000 Hz	0.5 ug /√ Hz
Power requirements	
	Constant current : +2 to +10mA DC
	Voltage : +22 to +28 VDC
Protection	
Overvoltage	Yes
Reverse polarity	Yes
ESD Protection	> 40 V

## Environmental

Temperature, operating continuous : 101.51 (max. current =4mA)	
A= 3X, 5X, 6X	-55 to 120 °C (-65 to 250 °F)
A=9X (500 mV/g)	-.55 to 90 °C (-65 to 212 °F)
A=0X (1000 mV/g)	-55 to 70 °C (-65 to 158 °F)
Humidity / Enclosure	
B=1, 2	Not affected, hermetically sealed, 1E-8 torr.l/s, >IP68
B=5, 7, 8	IP68, epoxy sealed
Acceleration limit : Shock	5000 g peak
Continuous vibration	500 g peak
Base strain sensitivity	0.0002 g pk/u strain (AA=6D)
Temp. transient sens. (3Hz, LLF, 20dB/dec)	5 mg/°C (AA=6D)
Acoustic sensitivity (164 dBSP)	0.5 mg (AA=6D)
Electromagnetic sens. (50Hz, 0.03 T)	0.2 g (AA=6D)

## Physical

Design	Ceramic, annular shear mode
Weight with connector	
A=3 (10 mV/g)	80 gr Nom (2.8 Oz)
A=5, 6 (50, 100 mV/g)	85 gr Nom (3.0 Oz)
A=9, 0 (500, 1000 mV/g)	95 gr Nom (3.4 Oz)
Weight with Integral cable : add sensor weight above + ...	
BB=5(CC-DD)	40gr/m
BB=7(CC-DD)	60 gr/m
BB=8(CC-DD)	105 gr/m
Material	AISI 316L, DIN 1.4404 (Stainless steel)



Mounting torque (M6, M7, M8 suffix) 2,4 N.m (21 in-lbs)

### European Directive

EMC Directive	2014/30/EU
Standards	61326-1
RoHS Directive	2011/65/EU
Certificate	101.51-YN_Rohs2

### Atex & IECEx Approval (YY=Y1)

Atex Directive	2014/34/EU
Standards	EN 60079-0, Atex General EN 60079-11, Intrinsic safety, Gas, Dusts
Certificates	LCIE 18 3031 X IECEX LCIE 18.0036X
Installation Drawing	101.51-Y1_IMI
EU Declaration of Conformity	101.51-Y1_EUDC

### Accessories, supplied

Calibration supplied Sensitivity (5g, 160 Hz)

### Accessories, not supplied

Cable assembly B=1 (Mil connector)	
Polyurethane cable (90°C)	10.01-A01-B22-06-Length
FEP Teflon cable (200°C)	10.01-A01-B22-02-Length

Cable assembly B=2 (M12 connector)	
Polyurethane cable (90°C)	10.01-A01-E02-31-Length
FEP Teflon cable (200°C)	10.01-A01-E61-02-Length

For more cable option see Model 10.01 (specific cable harness).

Mounting Stud for M6 sensor thread	
M6 machine thread	191.01-06-06-1
1/4" 28 UNF machine thread	191.01-06-16-1
M8 machine thread	191.01-06-08-1
M10 machine thread	191.01-06-10-1

Mounting Stud for 1/4"28 UNF sensor thread	
M6 machine thread	191.01-16-06-1
1/4" 28 UNF machine thread	191.01-16-16-1
M8 machine thread	191.01-16-08-1

Calibration, back to back, Frequency response (10 Hz-10 kHz), 4 pages 501.11

Calibration, back to back, single point., A4 certificates 501.01

### Repair

Consult factory for replacement of connector in case of broken or bended pins. Repair of electronic is not possible.

Fig 1. Frequency Response, amplitude1

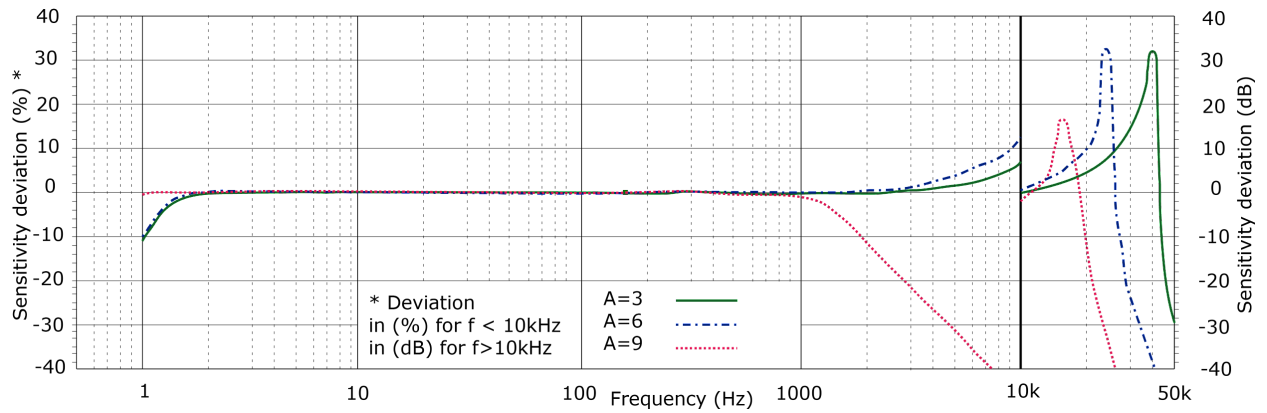

Fig 2. Low Frequency response, amplitude

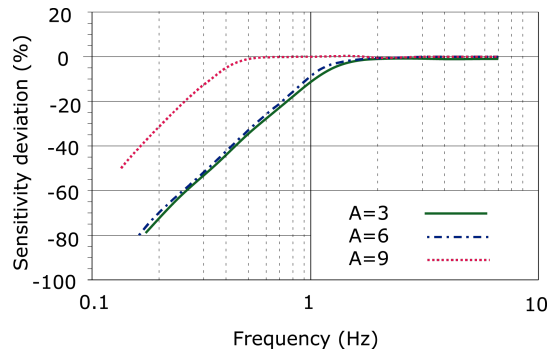

Fig 3. DC (Bias) deviation versus temperature

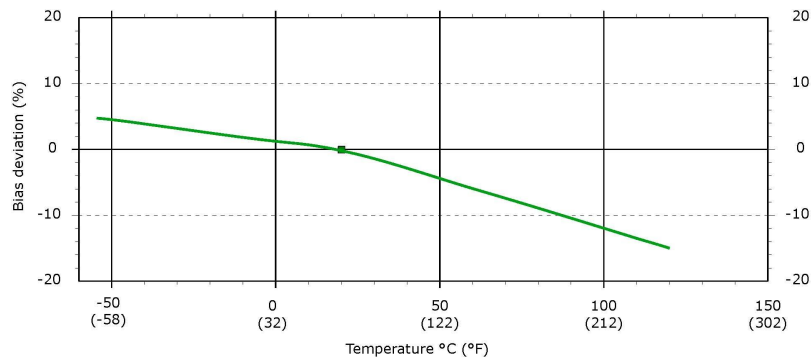
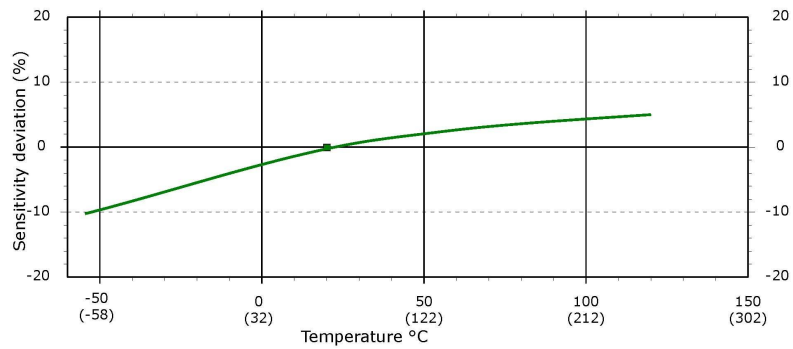

Fig 4. : Sensitivity deviation versus temperature



### Legal Information

Information furnished by VibraSens is believed to be accurate and reliable. However, no responsibility is assumed by VibraSens for its use, nor for any infringements of patents or other rights of third parties that may result from its use. Specifications subject to change without notice. Trademarks and registered trademarks are the property of their respective owner.