

POTATO PEELER MACHINE INSTRUCTION

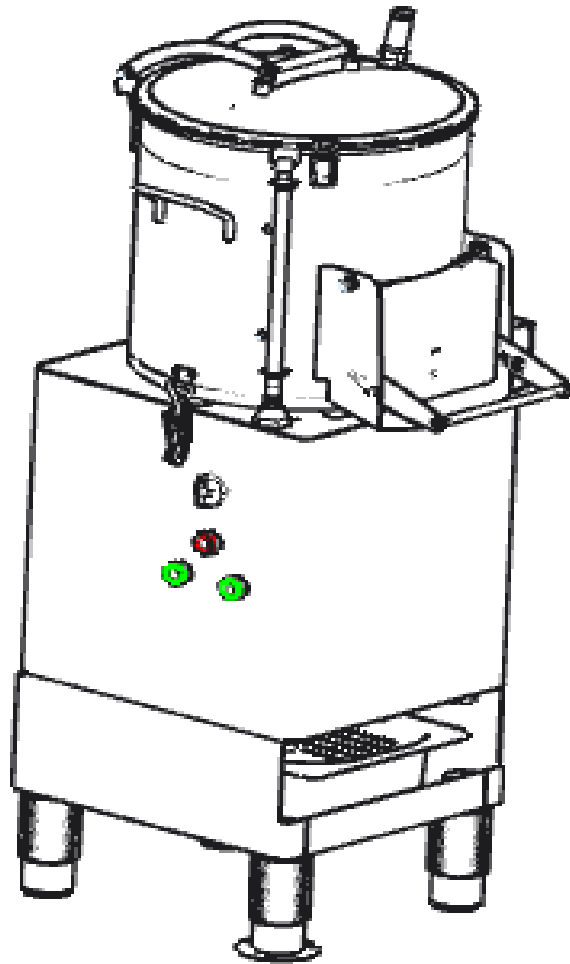

INTRODUCTION

- This manual has been written to provide the client with all information concerning the machine and the norms pertaining to it, apart from the use and maintenance instructions which enable it to be used in the best way possible, therefore maintaining its efficiency through time.
- This manual must be given to all personnel who will use or do maintenance on the machine.

INDEX OF CHAPTERS

CHAP.1 - MACHINE INFORMATION

- 1.1 —GENERAL PRECAUTIONS
- 1.2 —SAFETY DEVICES INSTALLED ON THE MACHINE
- 1.3 —DESCRIPTION OF THE MACHINE
 - 1.3.1 _General description
 - 1.3.2 _Constructive features
 - 1.3.3 _Machine makeup

CHAP.2 – TECHNICAL DATA

- 2.1 —DIMENSIONS, WEIGHT, CHARACTERISTICS...

CHAP.3 – RECEIVING THE MACHINE

- 3.1 —SHIPPING THE MACHINE
- 3.2 —CHECKING THE PACKAGE UPON RECEIPT
- 3.3 —DISPOSING OF THE PACKAGE

CHAP.4 – INSTALLATION

- 4.1 —MACHINE PLACEMENT
- 4.2 —ELECTRICAL CONNECTIONS
 - 4.2.1—MPP with single-phase motor
- 4.3—ELECTRICAL DIAGRAMS
- 4.4—OPERATIONAL CHECK

CHAP.5 –MACHINE USE

- 5.1 —CONTROLS
- 5.2 —LOADING AND WORKING THE PRODUCT

CHAP.6-ROUTINE CLEANING

- 6.1 —GENERALITIES

CHAP.7-MAINTENANCE

- 7.1—GENERALITIES
- 7.2—BELT
- 7.3—FEET
- 7.4—FEEDING CABLE
- 7.5-ATTENTION

CHAP.8-DISMANTLING

- 8.1—PUTTING IT OUT OF WORK
- 8.2—DISPOSAL
- 8.3—WEEE Waste of Electric and Electronic Equipment

CHAP.1 - MACHINE INFORMATION

1.1-GENERAL PRECAUTIONS

- The machine must only be used by trained personnel who are perfectly aware of the safety norms contained in this manual.
- If there is a turnover of staff , promptly provide proper training for new personnel.
- Even if safety devices are installed on the machine do not place hands near moving parts and avoid touching the machine with wet or damp hands.
- Before carrying out any type of maintenance or cleaning, disconnect the machine plug from the electrical outlet.
- When intervening for maintenance or cleaning purposes (therefore the protections are removed) carefully evaluate residual risks.
- During maintenance or cleaning always concentrate on the operation in progress.
- Regularly check the state of the feeding cable (completely unwinding the cable, avoiding twisting it , is advisable to avoid potential risks); a worn or broken cable can present serious danger of the electrical kind; avoid compressing the wire with weights, leaving it in contact with hot or sharp surfaces and pulling on it to unplug it from the outlet.
- If the machine shows signs of malfunctioning or does not work, do not use it or try to repair it; contact the “Assistance Centre”, indicated on the back of this manual.
- The OUT pushbutton must only be used for unloading the worked product.
- The machine must only be used for cleaning potatoes/mussels/onions.

The manufacturer is not responsible in the following cases:

- if the machine is mishandled or the safety devices are installed by unauthorized personnel;
- if components are replaced with unoriginal parts;
- if the instructions in this manual are not followed carefully;
- if the machine surfaces are treated with inappropriate products(inflammable, corrosive or harmful substances).

Whatever the explanation households with marks on attention.



1.2-SAFETY DEVICES INSTALLED ON THE MACHINE

The mechanical and electrical devices GB safety 4706.1-2005 household and similar USES electrical safety general requirement, GB 4706.30-2002 household and similar USES electrical safety kitchen machine special requirements

The machine is equipped with:

- a starting device consisting of a control card insulated in IP 34,24 Volts, which enables:
 - turning the machine on and off;
 - controlling the unloading of the product;
- a micro, which causes the machine to stop in case the cover or discharge door opens(see *FIGn^o 1*),does not allow the machine to turn on if it is not in the closed position;
- an N.V.R. device in the control circuit which requires the machine to be restarted if there is an accidental lack of electricity and it enables restarting the machine

only by using the START pushbutton;

Furthermore the machine is equipped with an upper transparent cover which enables checking the working of the product in progress without any risks.

1.3–DESCRIPTION OF THE MACHINE

1.3.1–General description

The line of CE professional machine has been designed and manufactured by our company with the precise objective of guarantee:

- maximum safety during use ,cleaning and maintenance;
- maximum hygiene, the result of the careful selection of materials which come into contact with foodstuffs and due to the elimination of sharp edges from the part which comes into contact with the product ,in such a way to guarantee easy and thorough cleaning;
- all the components are robust and stable;
- maximum silence thanks to the belt transmission.

1.3.2–Constructive features

Professional I HLP is made of Stainless steel, Aluminium- Magnesium alloy.

The discharge door is polished aluminium; the adjustable feet are stainless steel; the cover is a plastic material, while the hopper is made of Aluminium-magnesium alloy, the work plate is aluminium with the disk made of Stainless steel, Aluminium-Magnesium alloy; the internal walls of the container are in abrasive resin to enable a higher lever of abrasion with the product to be worked.

1.3.3–Machine makeup

FIGn ° 1-General view of the machine

KEY:

1. pushbutton strip
2. cover
3. feeding tap
4. container
5. discharge door
6. pot
7. feet
8. water tank

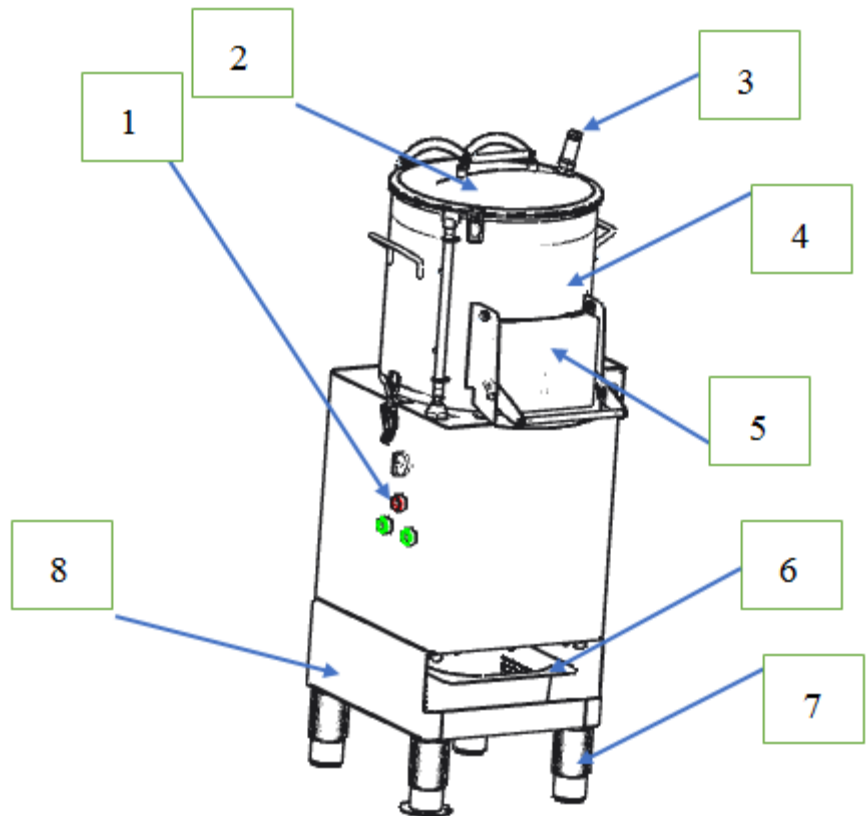

CHAP.2 – TECHNICAL DATA

2.1 – DIMENSIONS,WEIGHT, CHARACTERISTICS...

FIGn ° 2—Drawings of dimensions

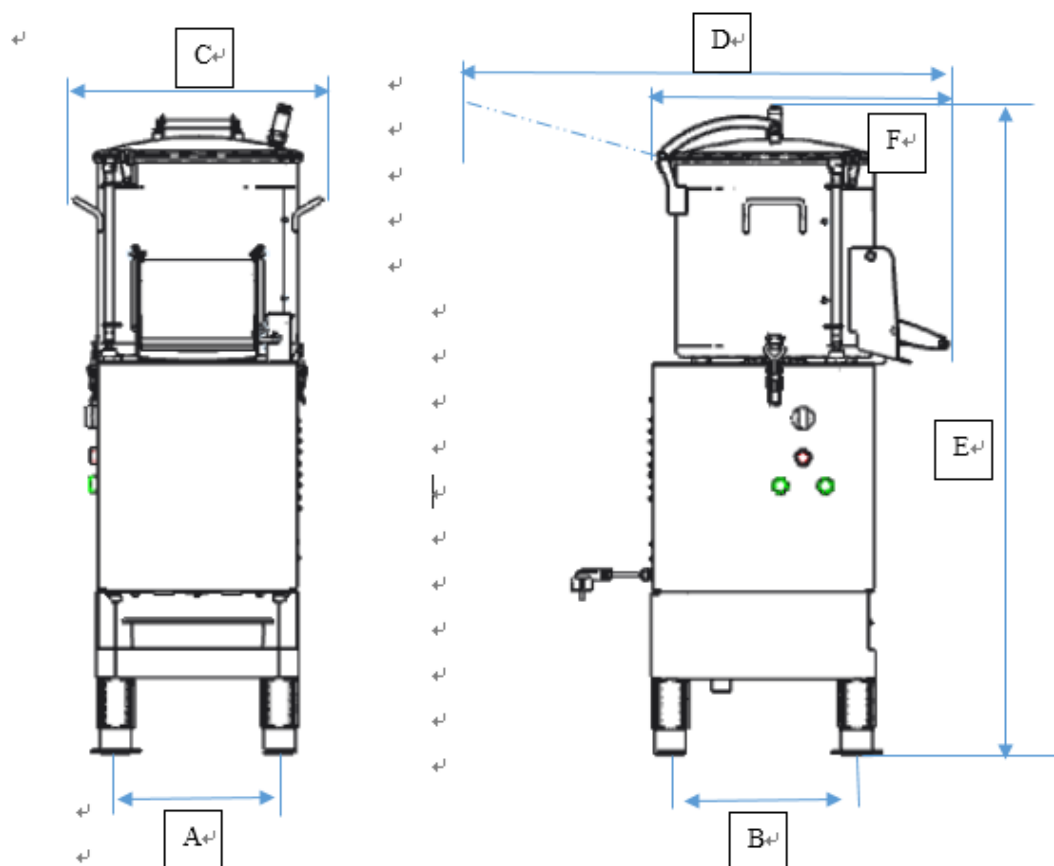

TAB.n° 1-MEASUREMENTS AND TECHNICAL FEATURES

Model		6KG	10KG	20KG
Power source		220-240V/100~120V 50Hz/60Hz		
A*B	mm	239*300	289*330	339*380
C*F*E	mm	385*516*1062	435*546.5*1151	490.6*596.4*1196
D(when open the cover)	mm	730	830	943
Capacity	kg	10L For 6	20L For 10	35L For 10
Output/h.	kg/h	100	165	300
Motor	Hp	1/2	1	1.2
Power	watt	370	750	950
Net weight	kg	44	61	69
Noise level	dB	≤75	≤75	≤75

ATTENTION: The electrical characteristics the machine is prearranged for are indicated by a plate (*attached to the back*);before connecting the machine see **4.2 electrical connection**.

CHAP.3 – RECEIVING THE MACHINE

3.1--SHIPPING THE MACHINE (see FIGn ° 3)

The machine leaves our warehouses correctly packaged, such a package consists of:

- an external box in robust cardboard and a wooden pallet;

- b) the machine;
- c) this manual;
- d) stand with sieve. (Installed on the machine)

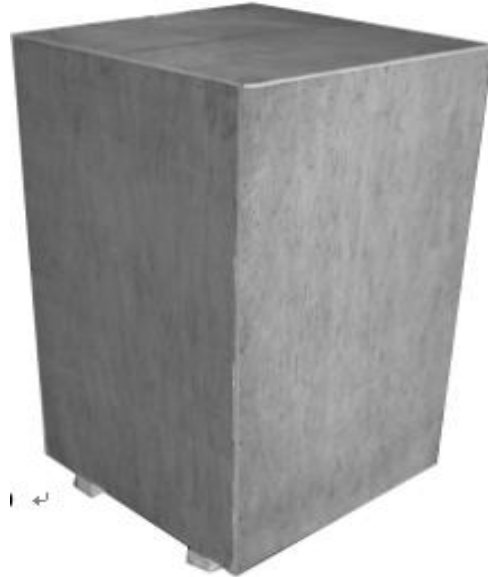

FIGn ° 3-Package description

3.2–CHECKING THE PACKAGE UPON RECEIPT

When the package is received, if there is no external damage, open the package and check that all the material is inside(see FIGn ° 3)

If the package shows signs of mishandling, bumps or falls upon delivery, the shipping company must be made aware of the damage within 3 days of the delivery date indicated on the documents, and a detailed report must be written on the damage to the machine. **Do not overturn the package!!** when the package is being moved make sure that it is firmly held in the four fundamental points(keeping it parallel to the floor).

3.3–DISPOSING OF THE PACKAGE

The package components (cardboard, pallets, plastic and polyurethane foam strap) are produced like solid urban waste, therefore they can easily be disposed of.

If the machine id installed in countries with particular norms, dispose of the packages according to the laws in force.

CHAP.4 – INSTALLATION

4.1 – MACHINE PLACEMENT

When choosing the plane the machine will be placed on the dimensions shown in Tab.1 must be considered (based on model),therefore the surfaces must be wide enough to hold it ,and it must be well-levelled and dry.

Prearrange a discharge tube (ϕ 32mm.)under the machine and a drain trap on the floor, or a floor grate to collect the water or other waste material.

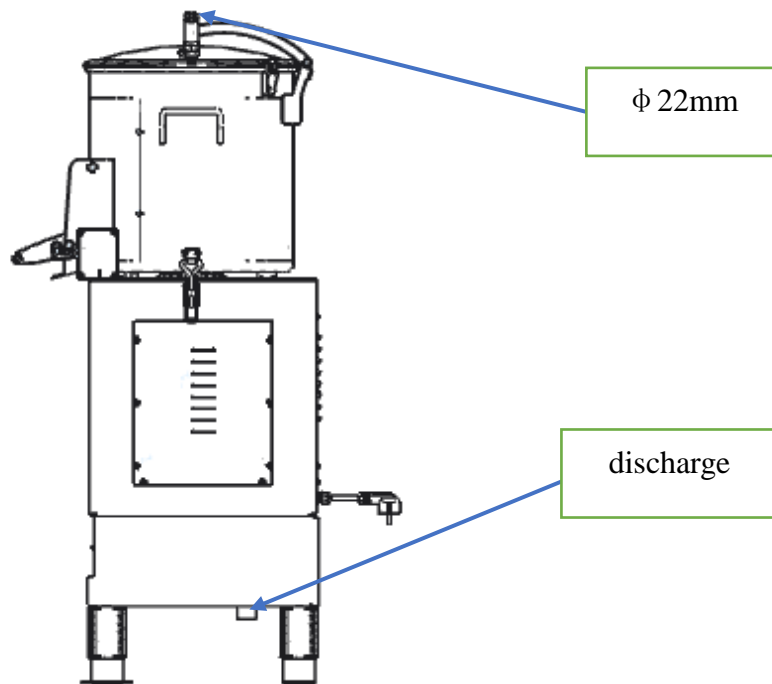

Furthermore the machine must be placed as near as possible to a faucet (ϕ 22mm.), which enables

the feeding tube to be easily and safely attached (see FIGn° 4)

Once the machine is placed proceed to blocking it by fastening it to the floor with the setscrews on the flanged feet (see FIG.). Furthermore the machine must be placed in an environment with a maximum humidity of 75%, which is not salty and has a temperature between $+5^{\circ}\text{C}$ and $+25^{\circ}\text{C}$; in any case in environments which do not bring about its malfunctioning.

FIGn° 4-Discharge diagram

4.2 --ELECTRICAL CONNECTIONS

4.2.1—HLP with single-phase motor

The machine is outfitted with a feeding cable with a cross section area of $3 \times 1.5\text{mm}^2$, length 1.5m.

Connect the machine to 220V.-240V/50HZ–60HZ, 110V/60HZ

Furthermore check that the data shown on the serial number-technical plate (FIGn° 5) correspond to the data on the delivery notes.

FIGn° 5-Serial number-technical plat

Before finally connecting the machine to the three-phase feeder line, check the direction of rotation of the cap by pressing the START pushbutton (see FIGn° 8) then immediately stop it by pressing the STOP pushbutton.

The direction of rotation of the cap seen from the discharge outlet must be counterclockwise; if the direction of rotation is not exact, invert two of the three feeding wires in the plug or outlet (see FIGn° 7).

4.3- ELECTRICAL DIAGRAMS

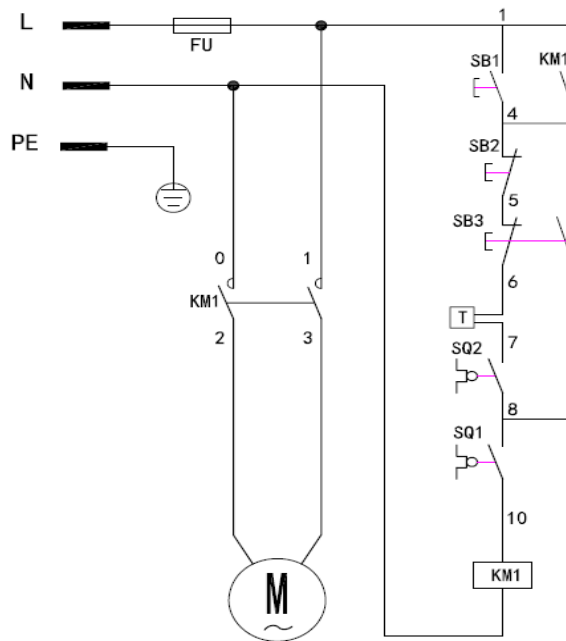

FIGn ° 6-1ph electrical diagram

4.4-OPERATIONAL CHECK

Before proceeding to testing make sure the upper cover and the discharge door are well-blocked, then check the running of the machine with the following procedure:

- 1 check that the upper cover and the discharge door are closed well;
- 2 press the START pushbutton and then the STOP one;
- 3 repeat the same operation, checking that the cap rotates in a counterclockwise direction(see FIGn ° 7) through the closed transparent upper cover;
- 4 check if the machine stops when running by opening the cover or discharge door, and once it is closed if the machine restarts by pushing the START pushbutton;
- 5 to discharge the material open the discharge door , keeping it open with your right hand and at the same time pushing the OUT and START buttons on the pushbutton strip with your left hand ; the machine will start by unloading the potatoes by centrifugal force(see FIGn ° 10).

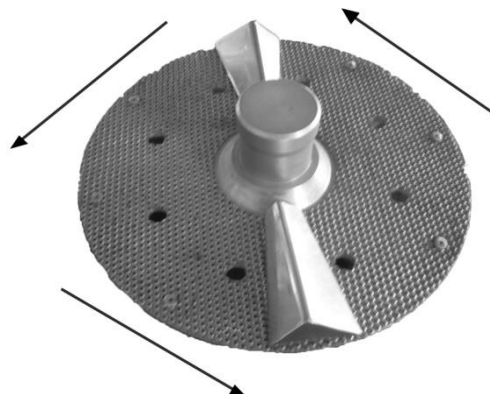

CHAP.5 –MAC1

5.1 –CONTROL

The controls are

p above.

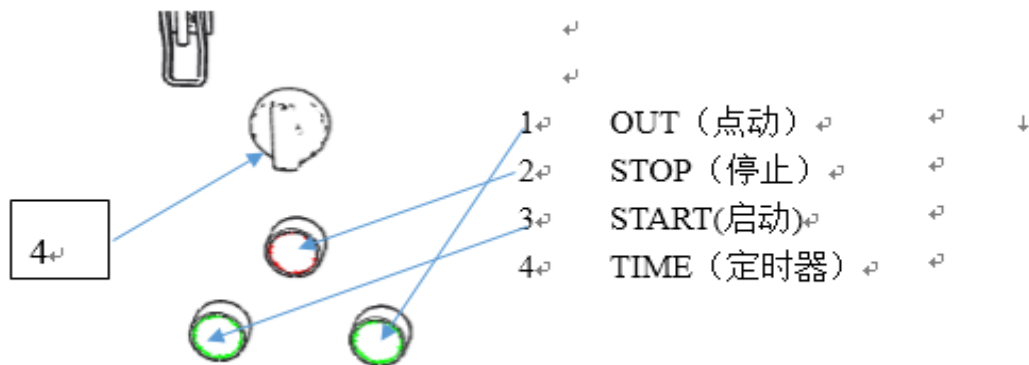

FIGn ° 8-Loading the product

5.2-LOADING AND WORKING

THE PRODUCT (see FIGn ° 9)

NB: The goods to be worked are loaded gradually on the cap from the upper cover when the motor is off.

Adhere to the following procedure:

- 1 load the product from the upper cover, making sure that the discharge door is closed well;

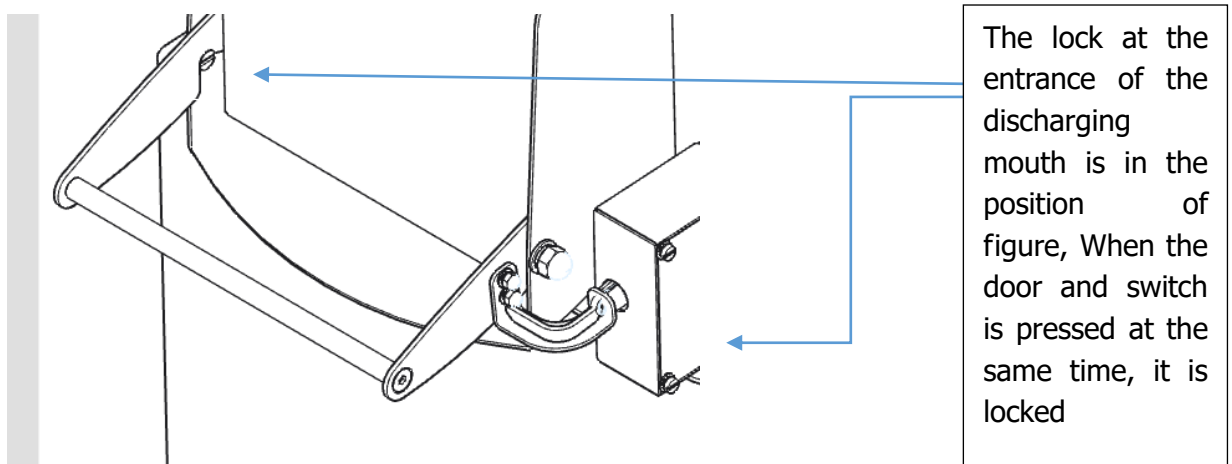

FIGn ° 9-Loading the product

- 2 check that the machine is not too full and that the level of the product does not go over the abrasive band inside the machine;
- 3 close the upper cover;
- 4 open the water flow using the faucet on the hopper;

Running:

- 1 set the desired work time with the timer(max time 5 min.);
- 2 then start the machine by pressing the START pushbutton;
- 3 if the cover and/or discharge door are accidentally opened or moved while the machine is running, the machine will stop; when closed press the START button;

- 4 open the water flow using the faucet on the hopper;
- 5 if the machine is outfitted with a stand with sieve, repeatedly unload the slag tray, to avoid the water dripping.

Unloading the worked product:

- 1 close the water faucet and put a big container near the discharge outlet;
- 2 to unload the material open the discharge door , keeping it open with your right hand ; press the OUT and START pushbutton at the same time with OUT your left hand; the machine will start unloading the product by centrifugal force;
- 3 once the unloading is complete the machine will stop by releasing the pushbuttons and the discharge door;

N.B.: Avoid making an empty machine turn.

FIGn ° 10-Unloading the product

CHAP.6-ROUTINE CLEANING

ATTENTION: never put hands inside the moving machine.

Cleaning and maintenance operations are carried out only when the machine is off and the feeding cable is unplugged.

6.1-GENERALITIES

Before cleaning the machine the feeding plug must be disconnected from the network to completely isolate the machine.

- The machine must be cleaned at the end of every work day and all the parts of the machine (completely removable) which come into direct or indirect contact with the worked foodstuff must be carefully cared for.
- Both the inside and the outside of the machine must be cleaned because the residual waste can be seriously damaging.
- The machine must not be cleaned with water cleaners , high-pressure jets of water, brushes, and anything else which can damage it on the surface. Acidic ,corrosive or inflammable substances must not be used.
- If the machine has a stand with a sieve repeatedly empty the slag tray to avoid the water dripping.

CHAP.7-MAINTENANCE

7.1-GENERALITIES

Before carrying out any maintenance activity it is necessary to :

Disconnect the plug from the electrical outlet to completely isolate the machine from the rest of the system.

7.2-BELT

The belt does not need any adjustments. Usually, after 3/4 years it must be replaced, in this case call the “ASSISTANCE CENTER”.

7.3-FEET

The feet could deteriorate with time, thus reducing the stability of the machine. therefore they must be replaced.

7.4-FEEDING CABLE

Periodically check the wear of the cable and call the “ASSISTANCE CENTER” to

replace it.

7.5-ATTENTION

When cleaning machine, please don't damaged parts, If damaged Please return maintenance

CHAP.8-DISMANTLING

8.1-PUTTING IT OUT OF WORK

If for some reason it is decided to put the machine out of work make sure that it cannot be used by anyone: unplug the electrical connections.

8.2-DISPOSAL

Once it has been put out of work the machine can be eliminated. To correctly dispose of the machine get information from any company responsible for such a service and take careful note of the material used for the various components.

8.3-WEEE Waste of Electric and Electronic Equipment

In accordance with the GB 4706.49-2000 household and similar USES electrical safety waste food processor, the special requirements of standard in electronic equipment on the use of certain hazardous substances.



This symbol, crossed out wheeled bin, on the product or in its packaging indicates that this product must not be disposed of with your other household waste.

Separate waste collection of this appliance is organised and managed by the manufacturer. It is the user's responsibility to contact the manufacturer and follow the waste treatment system the manufacturer has adopted for separate waste collection.

The separate collection and recycling of your waste equipment at the time of disposal will help to conserve natural resources and ensure that it is recycled in a manner that protects human health and the environment

