

vitatron

G70 DR MRI SureScan™ G70A2



Dual chamber rate responsive pacemaker (DDDR)

Contents

1 CE mark of conformity	5
1.1 CE mark of conformity	5
2 System overview	5
2.1 Introduction	5
2.2 System description	5
3 Indications	6
4 Contraindications	6
5 MRI conditions for use	6
6 Expected clinical benefit	7
7 Summary of safety and clinical performance	7
8 Intended purpose	7
9 Intended user	8
10 Intended patient population	8
11 Patient counseling information	8
12 Pre-implant considerations	8
13 Warnings, precautions, and potential adverse events	9
13.1 Warnings and precautions to ensure intended device function	9
13.2 Potential adverse events	12
14 Pacing mode information	13
15 Implant procedure	13
15.1 Verify sufficient device longevity	13
15.2 Verify lead and connector compatibility	13
15.3 Test the lead system	14
15.4 Connect the leads to the device	14
15.5 Test the device operation	15
15.6 Position and secure the device	16
15.7 Program the device	16
15.8 Replace a device	17
16 Potential complications and emergency pacing	18
16.1 Potential complications	18
16.2 Emergency pacing	18
17 Product specifications	19
17.1 Physical characteristics	19
17.2 Electrical characteristics	20
17.3 Magnet operation and Elective Replacement Indicator (ERI)	22
17.4 Measuring methods	22
18 Device parameters	24
18.1 Shipping, nominal, and electrical reset parameters	24
18.2 Programmable parameters	29

18.3 Automatic and clinician-selectable diagnostics	35
18.4 Nonprogrammable parameters	36
19 Feature summary	37
20 Declaration of conformity	39
21 Explanation of symbols	39

1 CE mark of conformity

1.1 CE mark of conformity

C€0344

2 System overview

2.1 Introduction

About this manual – This document is primarily an implant manual. Regular patient follow-up sessions should be scheduled after implant. Follow-up procedures such as monitoring battery measurements and confirming therapy parameters are described in the product documentation that is included with the software that supports this device. To obtain additional copies of product documentation, contact a Vitatron¹ representative.

This manual describes the Vitatron G70 DR MRI SureScan² dual chamber, multiprogrammable, rate-responsive implantable pulse generator (IPG) bipolar/unipolar model G70A2. This device is also referred to as a pacemaker.

Additional manuals and documents with information about the device:

MRI technical manual – This manual provides MRI-specific procedures and warnings and precautions.

Reference manual – The reference manual describes pacemaker features in depth, and it provides procedures to conduct a patient session with a programmer. It also provides information to assess and optimize device performance for the patient. This information includes guidance to interpret collected data and to program parameter settings. The reference manual applies to all models in the Vitatron MRI SureScan family of pacemakers.

Medical Procedure and EMI Warnings and Precautions Manual for Health Care Professionals – This manual provides warnings, precautions, and guidance for health care professionals who perform medical therapies and diagnostic procedures on cardiac device patients. The manual also provides patient education information related to sources of electromagnetic interference (EMI) at home, at work, and in other environments.

2.2 System description

The Vitatron G70 DR MRI SureScan model G70A2 dual chamber implantable pulse generator (IPG) is a multiprogrammable cardiac device that monitors and regulates the patient's heart rate by providing single or dual chamber rate-responsive bradycardia pacing.

The MRI SureScan feature permits a mode of operation that allows a patient with a SureScan system to be safely scanned by an MRI machine while the device continues to provide appropriate pacing. When programmed to On, MRI SureScan operation disables arrhythmia detection, magnet mode, and all user-defined diagnostics. Before performing an MRI scan, refer to the MRI technical manual.

The users of this device include medical professionals (physicians, nurses, technicians, and their supporting staff) trained in surgery, cardiology, radiology, and magnetic resonance (MR) technology and able to implement the procedures documented in the instructions for use for this device.

Rate response – Rate response is controlled through an activity-based sensor.

Programmers and software – Use only Medtronic programmers and Vitatron application software to communicate with the device. Programmers and software from other manufacturers are not compatible with Vitatron devices.

For information about a specific programmer, go to www.manuals.medtronic.com to find the programmer manual.

¹ Vitatron® is a registered trademark of Vitatron Holding B.V.

² SureScan is a trademark of Medtronic, Inc.

Contents of sterile package – The package contains 1 implantable pulse generator and 1 torque wrench used to tighten setscrews.

2.2.1 Usage environments

The device is intended to be used in the following environments and conditions:

- The device will be implanted in a properly equipped, staffed, and sterile surgical environment. Implant will take place under standard surgical protocols and in the patient population for which the device is indicated.
- Post-surgical patient and device follow-up care will take place in a properly equipped and staffed cardiology clinic or office.
- MRI procedures for patients with this device will take place in a properly equipped and staffed MR facility, and in consideration of the conditions and requirements described in *Chapter 5, MRI conditions for use, page 6*.
- After having an implant, patients may resume their lives at home, at work, and in other environments with consideration of the advice and restrictions documented in the Medical Procedure and EMI Warnings and Precautions Manual for Health Care Professionals.

3 Indications

The Vitatron G70 DR MRI SureScan model G70A2 implantable pulse generator (IPG) is indicated for the following conditions:

- Accepted patient conditions warranting chronic cardiac pacing, which include:
 - Paroxysmal or permanent Type 2 second- or third-degree AV block
 - Symptomatic Type 1 second-degree AV block or block located at intra- or infra-His levels, regardless of symptoms
 - Symptomatic paroxysmal or transient sinus node dysfunctions with or without associated AV conduction disorders
 - Bradycardia-tachycardia syndrome to prevent symptomatic bradycardia or some forms of symptomatic tachyarrhythmias
 - Alternating bundle branch block
 - Bundle branch block with unexplained syncope and abnormal EPS or non-diagnostic evaluation
- Rate adaptive pacing in patients who may benefit from increased pacing rates concurrent with increases in activity

This device is also indicated for dual chamber and atrial tracking modes in patients who may benefit from maintenance of AV synchrony. Dual chamber modes are specifically indicated for treatment of conduction disorders that require restoration of both rate and AV synchrony, which include:

- Various degrees of AV block to maintain the atrial contribution to cardiac output
- VVI intolerance (for example, pacemaker syndrome) in the presence of persistent sinus rhythm
- Vasovagal syndromes or hypersensitive carotid sinus syndromes

4 Contraindications

The Vitatron G70 DR MRI SureScan model G70A2 implantable pulse generator (IPG) is contraindicated for dual chamber pacing in patients with chronic or persistent supraventricular tachycardias, including atrial fibrillation or flutter.

5 MRI conditions for use

A complete SureScan pacing system is required for use in the MR environment. A complete SureScan pacing system includes a SureScan device with SureScan leads. Any other combination may result in a hazard to the patient during an MRI scan.

Warning: Do not scan a patient without first programming the MRI SureScan mode to On. Scanning the patient without programming the MRI SureScan mode to On may result in patient harm or damage to the SureScan pacing system.

Note: The MRI SureScan mode cannot be programmed to On if the device is recommended for replacement.

Cardiology requirements

Patients and their implanted systems must be screened to meet the following requirements:

- The patient has no implanted lead extenders, lead adaptors, or abandoned leads.
- The patient has no broken leads or leads with intermittent electrical contact, as confirmed by lead impedance history.
- The SureScan pacing system is implanted in the left or right pectoral region.
- The pace polarity parameters are set to Bipolar for programming the MRI SureScan mode to On.
- The SureScan device is operating within the projected service life.
- For patients whose device will be programmed to an asynchronous pacing mode when the MRI SureScan mode is programmed to On, no diaphragmatic stimulation is present when the paced leads have a pacing output of 5.0 V and a pulse width of 1.0 ms.

Caution: It is not recommended to perform an MRI scan if the right ventricular (RV) lead pacing capture threshold is greater than 2.0 V at 0.4 ms for pacemaker-dependent patients. A higher pacing capture threshold may indicate an issue with the implanted lead.

Notes:

- For radiology requirements, refer to the MRI technical manual.
- **Before performing an MRI scan, refer to the MRI technical manual for MRI-specific warnings and precautions.**

Patient monitoring and rescue requirements

- Continuous patient monitoring is required during the MRI scan.
- In the event that patient rescue is required, an external defibrillator must be immediately available.

6 Expected clinical benefit

The clinical benefits of pacemakers depend on the etiology and severity of patient bradycardia. These benefits may include the reduced incidence of syncope and extended survival. For many indicated patients, the clinical benefits may also include variable relief from the common symptoms of bradycardia, such as dyspnea and fatigue. The potential combination of these clinical benefits may improve the quality of life.

7 Summary of safety and clinical performance

The Summary of Safety and Clinical Performance (SSCP) can be found at <https://ec.europa.eu/tools/eudamed>. Search for the SSCP using the manufacturer and device name, and any of the following elements, as applicable: device model, reference number, catalog number, or the Basic Unique Device Identification (Basic UDI-DI) number — 0763000B00005427P.

8 Intended purpose

Pacemakers are intended for long-term use to monitor and regulate the patient's heart rate. Pacemakers sense intrinsic electrical activity through lead electrodes, analyze heart rhythms based on programmed detection parameters, and deliver pacing pulses to treat bradyarrhythmias.

The software is intended to provide information which is used to make decisions with diagnostic or therapeutic devices.

9 Intended user

The users of this device include medical professionals (physicians, nurses, technicians, and their supporting staff) trained in surgery, cardiology, radiology, and magnetic resonance (MR) technology (MR technology is not applicable for non-MR devices) and able to implement the procedures documented in the instructions for use for this device. Only physicians who have received appropriate training should implant a pacemaker.

10 Intended patient population

The device is intended to treat indicated patients with bradyarrhythmias. Additional considerations should be made when pacing patients with the conditions identified below. Refer to the current European Society of Cardiology (ESC) and European Heart Rhythm Association (EHRA) guidelines on cardiac pacing for the most up-to-date medical consensus on pacemaker treatment for these specific conditions. The information for each condition listed below is summarized from these guidelines.

Pacing after acute myocardial infarction (MI) – There is no evidence that cardiac pacing improves the outcomes in patients with AV block that resolves spontaneously or in patients with anterior myocardial infarction that is complicated by new-onset bundle branch block and transient AV block.

Pacing after cardiac surgery, TAVI, and heart transplantation – Some bradyarrhythmias are transient and resolve after surgery. A period of clinical observation should be made prior to permanent pacemaker implant to determine if the bradyarrhythmia is transient.

Pregnancy – For women who have a junctional escape rhythm with a stable, narrow QRS complex, pacemaker implantation can be deferred until after delivery. However, women with complete heart block who exhibit an escape rhythm with a slow, wide QRS complex should undergo pacemaker implantation during pregnancy. The risks of pacemaker implantation are generally low and an implant can be performed safely, especially if the foetus is beyond 8 weeks' gestation. A pacemaker for the alleviation of symptomatic bradycardia can be implanted at any stage of pregnancy using echo guidance or electro-anatomic navigation to avoid fluoroscopy.

Children and congenital heart disease – Permanent pacing is indicated for congenital AV block and postoperative advanced second degree or complete AV block that does not resolve. Pacing is also indicated for symptomatic sinus node disease when there is a correlation between symptoms and bradycardia.

11 Patient counseling information

In accordance with local regulations, healthcare providers should review the instructions for use for applicable information to be shared with the patient. A patient implant card, which contains identifying information about the implanted device, is included in the device package. After device implant, complete the patient implant card and provide it to the patient before they are discharged. Healthcare providers should communicate the following instructions to their patients:

- Always carry their implant card with them.
- Access additional information about their device on the website that is listed on their patient implant card.
Note: If the patient is unable to access the website, the physician must provide the information from the website to the patient.
- Always inform any healthcare personnel that they have an implanted device before any procedure has begun.
- Contact their healthcare provider if they notice any new or changing symptoms.

12 Pre-implant considerations

Patient evaluation for the implant of the Model G70A2 system should include the following consideration about a concomitant implant with a neurostimulator:

Concomitant neurostimulator and cardiac device implants – Some patients have medical conditions that require the implant of both a neurostimulator and a cardiac device (for example, a pacemaker, a defibrillator, or a

monitor). In this case, physicians (for example, a neurologist, a neurosurgeon, a cardiologist, and a cardiac surgeon) involved with either device should contact their Medtronic representative before implanting the patient with the second device. Based on the particular devices that the physicians have prescribed, Medtronic can provide the necessary precautions and warnings related to the implant procedure. For information about how to contact Medtronic, see the telephone numbers and addresses provided on the back cover of this manual.

13 Warnings, precautions, and potential adverse events

SureScan System - A complete SureScan system is required for use in the MR environment. Before performing an MRI scan, refer to the MRI Technical Manual for MRI-specific warnings and precautions.

A complete SureScan system only includes components that have been certified by Medtronic as being MR conditional.

13.1 Warnings and precautions to ensure intended device function

13.1.1 Device operation

Battery depletion – Carefully monitor device longevity by checking battery voltage and replacement indicators. Battery depletion eventually causes the device to stop functioning.

Capture Management – Capture Management does not program atrial outputs above 5.0 V or 1.0 ms. If the patient needs a pacing output higher than 5.0 V or 1.0 ms, manually program the amplitude and pulse width. If a lead dislodges partially or completely, Capture Management may not prevent loss of capture.

Concurrent devices – Output pulses, especially from unipolar devices, may adversely affect device sensing capabilities. If a patient requires a separate stimulation device, either permanent or temporary, allow enough space between the leads of the separate systems to avoid interference in the sensing capabilities of the devices. Previously implanted pulse generators and implantable cardioverter defibrillators should generally be explanted.

Crosstalk – Crosstalk may cause the device to self-inhibit, which results in no pacing. Program Ventricular Safety Pacing to On to prevent inhibition due to crosstalk.

Electrical isolation during implant – Do not allow the patient to have contact with grounded electrical equipment that might produce electrical current leakage during implant. Electrical current leakage may induce tachyarrhythmias that may result in the patient's death.

Electrical reset – Electrical reset can be caused by exposure to temperatures below -18°C or strong electromagnetic fields. Advise patients to avoid strong electromagnetic fields. Observe temperature storage limits to avoid exposure of the device to cold temperatures. If a partial reset occurs, pacing resumes in the programmed mode with many of the programmed settings retained. If a full reset occurs, the device operates in VVI mode at 65 min^{-1} . Electrical reset is indicated by a programmer warning message that is displayed immediately upon interrogation. To restore the device to its previous operation, it must be reprogrammed.

See *Section 18.1, Shipping, nominal, and electrical reset parameters, page 24* for a complete list of preserved and changed partial and full reset parameters.

Epicardial leads – Epicardial leads have not been determined appropriate for use with the Ventricular Output Management feature. Program Ventricular Output Management to Off if implanting an epicardial lead. **Note:** Epicardial leads compromise the ability to safely perform an MRI scan on the MRI SureScan pacing system. Patients with epicardial leads are contraindicated for an MRI scan.

Lead compatibility – Do not use another manufacturer's leads without demonstrated compatibility with Vitatron devices. If a lead is not compatible with a Vitatron device, the result may be undersensing of cardiac activity, failure to deliver necessary therapy, or a leaking or intermittent electrical connection. **Note:** Bipolar or unipolar leads may be used with the G70 DR MRI SureScan model G70A2 device, but if a lead other than a bipolar MRI SureScan lead is used, the system is contraindicated for MRI scans.

Lead connection – Consider the following information when connecting the leads and the device:

- Cap abandoned leads to avoid transmitting electrical signals.
- Plug any unused lead ports to protect the device.
- Verify lead connections. Loose lead connections may result in inappropriate sensing and failure to deliver arrhythmia therapy.

Muscle stimulation – Muscle stimulation (for example, due to high-output unipolar pacing) may result in pacing at rates up to the Upper Sensor rate in rate responsive modes.

Pacemaker-mediated tachycardia (PMT) intervention – Even with the PMT Intervention feature programmed to On, PMTs may still require clinical intervention, such as device reprogramming, drug therapy, or lead evaluation.

Pacing and sensing safety margins – Lead maturation (at least one month after implant) may cause sensing amplitudes to decrease and pacing thresholds to increase, which can cause undersensing or a loss of capture. Provide an adequate safety margin when selecting values for pacing amplitude, pacing pulse width, and sensitivity parameters.

Rate control – Decisions regarding rate control should not be based on the ability of the device to prevent atrial arrhythmias.

Rate-responsive modes – Do not program rate-responsive modes for patients who cannot tolerate rates above the programmed Lower Rate. Rate-responsive modes may cause discomfort for those patients.

Shipping values – Do not use shipping values or nominal values for pacing amplitude and sensitivity without verifying that the values provide adequate safety margins for the patient.

Single chamber atrial modes – Do not program single chamber atrial modes for patients with impaired AV nodal conduction. Ventricular pacing does not occur in these modes.

Tip contacts – When implanting a device, ensure that the tip setscrew is properly engaged and all electrical contacts are sealed to prevent possible electrical leakage. Also, ensure that electrical contacts are sealed when using a lead extender or adaptor. Electrical leakage may cause a loss of output. **Note:** A lead extender or lead adaptor compromises the ability to safely perform an MRI scan on the SureScan pacing system. Patients with a lead extender or lead adaptor are contraindicated for an MRI scan.

Torque wrench – Use only the torque wrench supplied with the device. The torque wrench is designed to prevent damage to the device from overtightening a setscrew. Other torque wrenches (for example, a blue-handled or right-angled torque wrench) have torque capabilities greater than the lead connector can tolerate.

Twiddler's syndrome – Twiddler's syndrome, i.e., patient manipulation of the device after implant, may cause the patient to experience symptoms of loss of capture and/or extracardiac stimulation if the lead is dislodged.

13.1.2 Device system warnings and precautions for pacemaker-dependent patients

Asynchronous pacing modes – Asynchronous pacing modes (DOO, VOO, AOO) disable sensing. It is not appropriate to permanently program these pacing modes for pacemaker-dependent patients.

Diagnostic modes – Do not program diagnostic modes (ODO, OVO, and OAO) for pacemaker-dependent patients. These modes disable pacing. Instead, use the programmer's inhibit function for brief interruption of outputs.

Polarity override – Do not override the polarity verification prompt with bipolar polarity when a unipolar lead is connected. Overriding the polarity verification prompt results in no pacing output.

Threshold Margin Test (TMT) and loss of capture – Be aware that loss of capture during a TMT at a 20% reduction in amplitude indicates an inadequate stimulation safety margin.

Underlying Rhythm Test – Use caution when using the Underlying Rhythm Test to inhibit pacing. The patient is without pacing support when pacing is inhibited.

Ventricular Safety Pacing – Always program Ventricular Safety Pacing (VSP) to On for pacemaker-dependent patients. Ventricular Safety Pacing prevents ventricular asystole due to inappropriate inhibition of ventricular pacing caused by oversensing in the ventricle.

13.1.3 External devices during implant

External defibrillation equipment – Keep external defibrillation equipment nearby for immediate use during acute lead system testing, the implant procedure, or whenever arrhythmias are possible or intentionally induced during post implant testing.

External pacing instrument – Keep an external pacing instrument available for immediate use. When the lead is disconnected, pacemaker-dependent patients are without pacing support.

13.1.4 Handling and storage instructions

Follow these guidelines when handling or storing the device.

Avoid magnets – To avoid rapid battery depletion of the device, store the device in a clean area away from magnets, kits containing magnets, and any sources of electromagnetic interference.

Checking and opening the package – Before opening the sterile package tray, visually check for any signs of damage that might invalidate the sterility of the package contents.

Dropped device – Do not implant the device if it is dropped on a hard surface from a height of 30 cm or more after it is removed from its packaging.

Fluid immersion – Do not immerse the device in fluid or flush the connector ports at the time of implant. Doing so could adversely affect the performance of the device and lead system.

If the package is damaged – The device packaging consists of an outer tray and inner tray. Do not use the device or accessories if the outer packaging tray is wet, punctured, opened, or damaged. Return the device to Vitatron because the integrity of the sterile packaging or the device functionality may be compromised. This device is not intended to be resterilized.

If the package information is damaged – If any information on the outer package or the sterile package is defaced or damaged so that you cannot read it, notify a Vitatron representative so that the device can be replaced.

If the printed manual is illegible – If this manual is supplied in its printed form and any part of it is illegible, contact a Vitatron representative to request a replacement manual.

Single use – This device is intended for single use only. Do not reuse, reprocess, or resterilize this device. Reuse, reprocessing, or resterilization may compromise the structural integrity of the device or create a risk of contamination of the device that could result in patient injury, illness, or death.

Sterilization – Vitatron has sterilized the package contents with ethylene oxide before shipment.

Storage temperature – No specific temperature considerations are required for storage.

Transit temperature – Transport the package between -18°C and $+55^{\circ}\text{C}$. Device reset can occur at temperatures below -18°C . Device longevity can decrease and performance may be affected at temperatures above $+55^{\circ}\text{C}$.

“Use-by” date – Do not implant the device after the “Use-by” date because battery longevity could be reduced.

13.1.5 Explant and disposal

Consider the following information related to device explant and disposal:

- Explant the implantable device postmortem. In some countries, explanting battery-operated implantable devices is mandatory because of environmental concerns; please check the local regulations. In addition, if subjected to incineration or cremation temperatures, the device may explode.
- Vitatron implantable devices are intended for single use only. Do not resterilize and reimplant explanted devices.

- Contact the manufacturer for Return Mailer Kits to return explanted devices for analysis and disposal. See the back cover for addresses.

13.2 Potential adverse events

The following are known potential adverse events associated with the use of this product.

Note: Implant and usage of this product may result in adverse events which may lead to injury, death, or other serious adverse reactions.

- Allergic reaction
- Bradyarrhythmia
- Cardiac arrest
- Device migration
- Discomfort
- Dizziness
- Dyspnea
- Erosion
- Excessive fibrotic tissue growth
- Extracardiac stimulation
- Fever
- Heart block
- Hematoma
- Hemodynamic compromise
- Hemorrhage
- Hiccups
- Hospitalization
- Inability to deliver therapy
- Infection
- Lethargy
- Loss of pacing
- Mental anguish
- Necrosis
- Nerve damage
- Onset of persistent AF
- Palpitations
- Physical injury
- Return of cardiac symptoms
- Seroma
- Skeletal muscle sensation/twitching
- Skin disorders
- Syncope
- Tachyarrhythmia
- Tissue trauma
- Toxic reaction
- Undersensing

- Undesirable impact to proximal medical equipment
- Wound dehiscence

Note: If the patient encounters a serious incident with the device, contact your Vitatron representative and the competent authority in your state or regulatory body.

14 Pacing mode information

Pacemaker modes are described using the NBG code. The five-letter NBG code, named after The North American Society of Pacing and Electrophysiology (NASPE) and the British Pacing and Electrophysiology Group (BPEG), describes the operation of implantable pulse generators. The NBG code, which supersedes the ICHD Code, is described in *Table 1*.

Table 1. The Revised NASPE/BPEG Generic Code for antibradycardia pacing

Position:	I	II	III	IV	V
Category:	Chamber(s) Paced	Chamber(s) Sensed	Response to Sensing	Rate Modulation	Multisite Pacing ^a
	O = None A = Atrium V = Ventricle D = Dual (A + V)	O = None A = Atrium V = Ventricle D = Dual (A + V)	O = None T = Triggered I = Inhibited D = Dual (T + I)	O = None R = Rate modulation	O = None A = Atrium V = Ventricle D = Dual (A + V)
Manufacturers' designation only:	S = Single ^b (A or V)	S = Single ^b (A or V)			

^a Vitatron devices do not use the Multisite Pacing code.

^b The programmer displays A or V (not S) for chambers paced and sensed.

15 Implant procedure

Proper surgical procedures and sterile techniques are the responsibility of the physician. The following procedures are provided for information only. Each physician must apply the information in these procedures according to professional medical training and experience.

15.1 Verify sufficient device longevity

Complete the following steps prior to opening the pacemaker box:

1. Check the use-by date printed on the package.
2. Place the programmer head over the box and start the application.
3. Interrogate the device.
4. Confirm the battery voltage is at least 2.75 V at room temperature using the Reference Manual instructions for viewing battery status.
5. Contact your Vitatron representative if the use-by date or battery voltage is out of range.

15.2 Verify lead and connector compatibility

A complete SureScan pacing system is required for use in the MR environment. A complete SureScan pacing system includes a SureScan device with SureScan leads. Any other combination may result in a hazard to the patient during an MRI scan.

Warning: Verify lead and connector compatibility before using a lead with this device. Using an incompatible lead may damage the connector, result in electrical current leakage, or result in an intermittent electrical connection.

A lead adaptor may be needed to connect the lead to the device. Contact a Vitatron representative for questions about lead adaptor compatibility.

Note: Bipolar or unipolar leads may be used with the G70 DR MRI SureScan model G70A2 device, but if leads other than bipolar MRI SureScan leads are used, the system is contraindicated for MRI scans.

Note: If you are using a lead that requires an adaptor for this device, please contact your Vitatron representative for information about compatible lead adaptors.

Note: Lead adaptors compromise the ability to safely scan the SureScan pacing system during an MRI scan. Patients with lead adaptors are contraindicated for an MRI scan.

Select a compatible lead. Refer to *Table 2*.

Table 2. Lead and connector compatibility

Model	Polarity	Primary leads
G70A2	Bipolar/Unipolar	IS-1 ^a BI

^a IS-1 refers to the International Connector Standard (see Document No. ISO 5841-3) whereby pulse generators and leads so designated are assured of meeting the electrical and mechanical parameters specified in the IS-1 International Standard.

15.2.1 Connector dimensions

The following figure shows the connector dimensions for the model G70A2 device.

Figure 1. G70 DR MRI SureScan model G70A2 connector dimensions

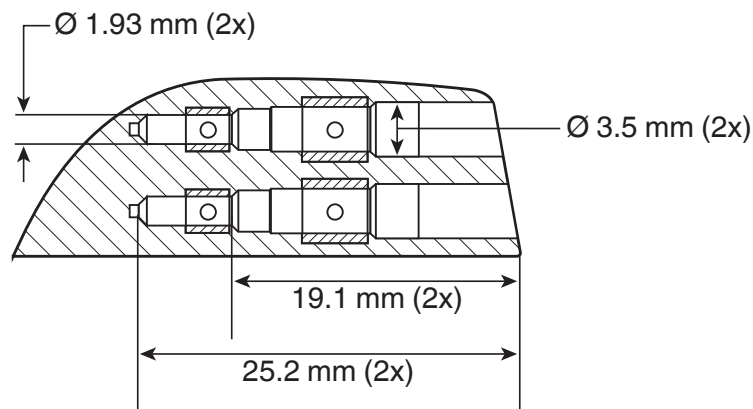

15.3 Test the lead system

For lead testing procedures, refer to the technical manual supplied with the implant support instrument.

15.4 Connect the leads to the device

Warning: Verify that the lead connections are secure. Loose lead connections may result in inappropriate sensing, which can cause inappropriate arrhythmia therapy or a failure to deliver arrhythmia therapy.

Caution: Use only the wrench supplied with the device. The wrench is designed to prevent damage to the device from overtightening a setscrew.

Connect the leads to the device by performing the following steps:

1. Insert the wrench into a grommet on the connector port.
 - a. Check that the setscrew is retracted from the connector port. If the connector port is obstructed, retract the setscrew to clear it. Do not disengage the setscrew from the connector block, see *Figure 2*.

Figure 2. Preparing the connector port setscrew

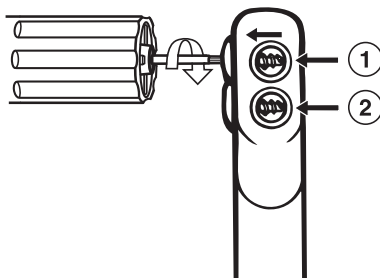

- 1 IS-1 connector port, A
- 2 IS-1 connector port, V

- b. Leave the wrench in the grommet until the lead is secure. This allows a pathway for venting trapped air when the lead is inserted, see *Figure 3*.

Figure 3. Wrench in the grommet

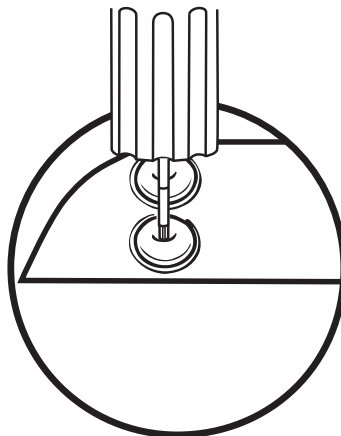

2. Push the lead connector pin into the connector port until the connector pin is visible in the lead viewing area. Sterile water may be used as a lubricant. Sealant is not required.

Figure 4. Inserting a lead into the device

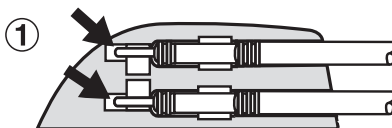

- 1 The lead pins are visible at the end of the viewing area.

3. Tighten the setscrew by turning the wrench to the right until the wrench clicks.
4. Repeat these steps for each lead.
5. Gently pull on the lead to confirm the connection.

15.5 Test the device operation

Warning: Keep an external pacing instrument available for immediate use. When the leads are disconnected, pacemaker-dependent patients are without pacing support.

Verify device operation by reviewing an ECG. If pacing and sensing are not adequate, perform one or more of the following tasks for one or both leads, as needed:

- Verify that the pacing threshold margin is adequate at the time of implant (and at each patient follow-up session).
- Verify the connection of the lead to the device. Confirm that the lead connector pin appears in the viewing area.
- Disconnect the lead from the device. Visually inspect the lead connector and lead. Replace the lead if necessary.
- Retest the lead. Inadequate electrical signals may indicate lead dislodgment. If necessary, reposition or replace the lead.

15.6 Position and secure the device

Note: Proper device placement can facilitate lead wrap and prevent muscle stimulation and device migration. The device may be implanted in right or left pectoral sites. Either side of the device may face the skin to facilitate excess lead wrap.

Note: Implant the device within 5 cm of the surface of the skin to optimize post-implant ambulatory monitoring.

1. Verify that each lead connector pin or plug is fully inserted into the connector port and that all setscrews are tight.
2. To prevent twisting of the lead body, rotate the device to loosely wrap the excess lead length. Do not kink the lead body.
3. Place the device and leads into the surgical pocket.
4. Suture the device securely within the pocket. Use non-absorbable sutures. Secure the device to minimize post-implant rotation and migration. Use a surgical needle to penetrate the suture hole on the device.

Figure 5. Location of suture hole

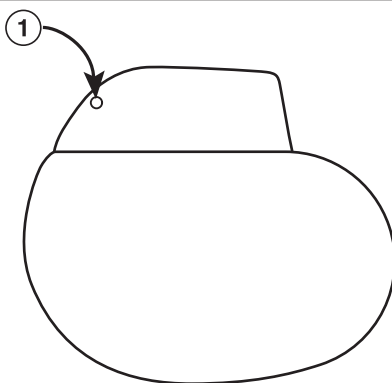

1 Suture hole

5. Suture the pocket incision closed.

15.7 Program the device

1. If unipolar leads are implanted, you may want to manually complete the Implant Detection process.
 - a. Tap **Params**.
 - b. Program the Pace Polarity and Sense Polarity parameters to Unipolar.

Note: If the patient experiences muscle stimulation while being paced in the unipolar configuration, reduce the amplitude or narrow the pulse width. Maintain adequate stimulation safety margins.
 - c. Tap **Additional Features...** and program the Implant Detection parameter to Off/Complete.
2. Verify that the pacing and detection parameters are programmed to values that are appropriate for the patient.

3. Enter the patient's information in the Patient Information screen.

Note: Use the Patient Information screen to document complete information about the implanted leads and other hardware implanted in the patient, including abandoned devices, leads, lead extenders or adaptors. This information will be used in the future if the patient needs to be evaluated for an MRI scan. For more information, see the programming guide.

15.8 Replace a device

To retain the ability to safely scan the SureScan pacing system during MRI scans, the MRI conditions for use in *Chapter 5, MRI conditions for use, page 6* must be followed. Refer to the MRI technical manual for additional information.

Warning: Bipolar or unipolar leads may be used with the G70 DR MRI SureScan Model G70A2 device, but if leads other than bipolar SureScan leads are used, the system is not approved for MRI scans. Before performing an MRI scan, refer to the MRI technical manual for additional information.

Warning: Abandoned leads or previously implanted non-MRI labeled leads compromise the ability to safely scan the SureScan pacing system during future MRI scans. When implanting a SureScan pacing system, consider the risks associated with removing previously implanted leads before removing the leads to maintain the ability to safely scan the SureScan pacing system. Refer to the MRI technical manual for additional information.

Warning: Keep an external pacing instrument available for immediate use. When the leads are disconnected, pacemaker-dependent patients are without pacing support.

Note: Any unused leads that remain implanted must be capped with a lead pin cap to avoid transmitting electrical signals. Contact your Vitatron representative for information about lead pin caps. Any capped or unused leads are considered abandoned leads in the MRI conditions for use, and their presence will contraindicate the system for MRI scanning.

15.8.1 How to explant and replace a device

If you are replacing a previously implanted device, perform the following steps:

1. Program the device to a mode that is not rate responsive to avoid potential rate increases while explanting the device.
2. Dissect the leads and the device free from the surgical pocket. Do not nick or breach the lead insulation.
3. Use a torque wrench to loosen the setscrews in the connector port.
4. Gently pull the leads out of the connector port.
5. Evaluate the condition of the leads (see *Section 15.3, Test the lead system, page 14*). Replace the leads if the electrical integrity is not acceptable or if the lead connector pin is pitted or corroded. If you explant the lead, return it to Vitatron for analysis and disposal.
6. Connect the leads to the replacement device (see *Section 15.4, Connect the leads to the device, page 14*).

Note: Lead adaptors may be needed to connect the leads to the replacement device (see *Section 15.2, Verify lead and connector compatibility, page 13*). Contact a Vitatron representative for questions about compatible lead adaptors.

Note: Lead adaptors compromise the ability to safely perform an MRI scan on the SureScan pacing system in the future. Patients with lead adaptors are contraindicated for an MRI scan.

7. Use the replacement device to evaluate stimulation thresholds and sensing potentials.
8. After confirming acceptable electrical measurements, place the device in the surgical pocket and suture the pocket incision closed.
9. Return the explanted device to Vitatron for analysis and disposal.

16 Potential complications and emergency pacing

16.1 Potential complications

The pacemaker/lead system may operate inappropriately or fail completely due to several potential complications. Note the following potential complications.

- Pacing thresholds can change over time. Clinicians are advised to program a pacing threshold margin that will prevent loss of capture in case of an increase in pacing threshold.
- Potential effects of premature battery depletion are decreased output voltage, no pacing output, loss-of-capture, Recommended Replacement Time (RRT), Elective Replacement Indicator (ERI), and eventual erratic pacing.
- Potential effects of pacemaker component(s) failure are loss of pacing output, pacing rate and other parameter changes, reversion to asynchronous mode, loss-of-capture, loss of programming capability, Recommended Replacement Time (RRT), Elective Replacement Indicator (ERI), and erratic pacing.
- Potential effects of the activity sensor detecting muscle or mechanical stimulation may increase the pacing rate to levels higher than expected for a given patient activity. In addition, an open or shorted activity sensor may cause rate response pacing to cease operating.
- Potential effects of electromagnetic interference (EMI) on the pacemaker's circuitry are pacing output inhibition, reversion to asynchronous mode, pacing synchronized to the EMI source, and a partial or full electrical reset condition.
- Electromagnetic interference (EMI) from electrocautery and defibrillation may cause any of the following conditions:
 - pacing output inhibition
 - temporary pause in pacing
 - permanent loss of pacing output
 - reversion to asynchronous mode
 - pacing synchronized to the EMI source
 - Recommended Replacement Time (RRT)
 - Elective Replacement Indicator (ERI)
 - partial or full electrical reset
- Potential effects of poor connection of lead to pacemaker connector block are intermittent or continuous loss-of-capture, failure to sense properly or loss of sensing, crosstalk between leads, and inhibition of pacing.
- Reversed connection of the atrial and ventricular leads will result in improper pacing and sensing operations.
- Potential effects of displaced or fractured lead are intermittent or continuous loss-of-capture and/or sensing, and inhibition of pacing. Cardiac perforation may cause intermittent or continuous loss-of-capture and/or sensing, inhibition of pacing, cardiac tamponade, and muscle or nerve stimulation. Myocardial irritability at the time of lead insertion may cause fibrillation or flutter. Elevation of pacing thresholds may cause a loss-of-capture.

16.2 Emergency pacing

Emergency pacing provides VVI pacing at high output settings in emergency situations for pacemaker-dependent patients. *Table 3* lists the emergency settings.

Table 3. Emergency settings

Parameter	Setting
Mode	VVI
Pacing Rate	70 min ⁻¹

Table 3. Emergency settings (continued)

Parameter	Setting
Ventricular	
Amplitude	7.5 V
Pulse Width	1.5 ms
Sensitivity	2.8 mV
Pace Polarity	Unipolar
Sense Polarity	Unipolar
Lead Monitor	Monitor Only
Ventricular Refractory Period	330 ms
Single Chamber Hysteresis	Off
Ventricular Output Management	Off

17 Product specifications

17.1 Physical characteristics

The following table and figure provide physical characteristics for the G70 DR MRI SureScan model G70A2 device.

Table 4. Physical characteristics

Volume ^a	12.1 cm ³
Mass	27.1 g
H x W x D ^b	44.7 mm x 47.9 mm x 7.5 mm
Surface area of titanium	30.7 cm ²
Radiopaque ID ^c	V5
Materials in contact with human tissue ^d	Titanium, polyurethane, silicone rubber, silicone rubber adhesive
Battery	Single-cell lithium-iodine

^a Volume with connector holes unplugged.

^b Grommets may protrude slightly beyond the can surface.

^c The radiopaque ID can be viewed in a fluoroscopic image of the device.

^d These materials have been successfully tested for the ability to avoid biological incompatibility. The device does not produce an injurious temperature in the surrounding tissue during normal operation.

The model G70A2 shield graphics are shown in *Figure 6*.

IS-1 refers to the International Connector Standard (see Document No. ISO 5841-3) whereby pulse generators and leads so designated are assured of meeting the electrical and mechanical parameters specified in the IS-1 International Standard.

For more information about the A-V connectors, see *Figure 2*.

Figure 6. Shield graphics: Model G70A2

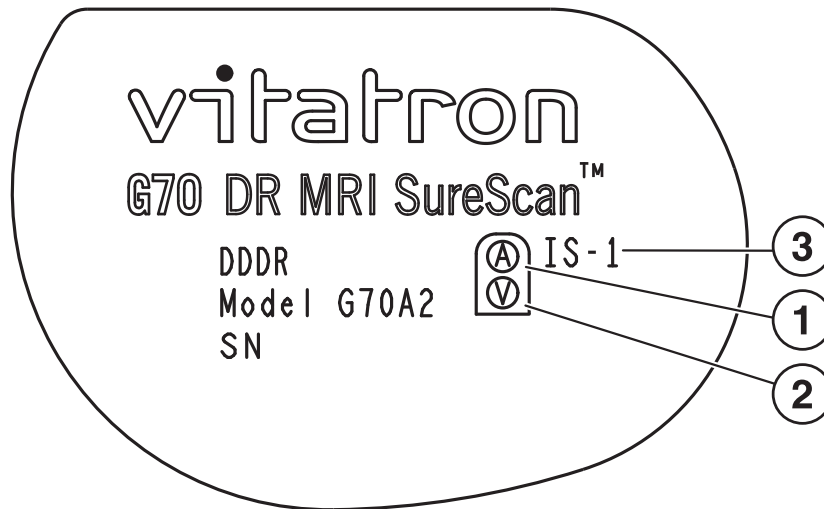

- 1 A = atrial
- 2 V = ventricular

3 IS-1 marking

17.2 Electrical characteristics

17.2.1 Output waveform

The output waveform for the pacemakers is provided in *Figure 7*.

Figure 7. Output waveform at nominal conditions (resistive load: 500 Ω)³

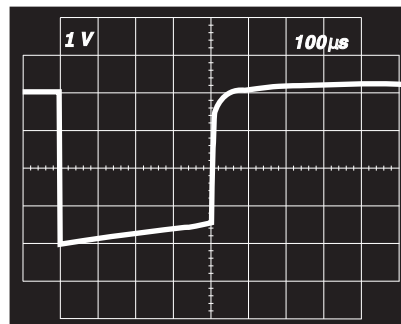

17.2.2 Battery information

Information about the battery used in the pacemaker models is provided in the following table.

Note: Usable capacity is defined from the Beginning of Service (BOS) to the End of Service (EOS).

Table 5. Battery characteristics

Manufacturer	Medtronic Energy and Component Center
Model	Sigma 263
Number of battery cells	1
Type	Single-cell lithium-iodine
Nominal voltage	2.8 V

³ Amplitude and pulse width measured per ISO 14708-2.

Table 5. Battery characteristics (continued)

Usable capacity	1.3 Ah
Residual capacity at RRT	0.08 Ah

Table 6. Current consumption

Current consumption (at 100% pacing) ^a	22.12 μ A
Current consumption (at 100% inhibition) ^b	12.93 μ A

^a Current consumption when pacing into $500 \Omega \pm 1\%$ loads at the Beginning of Service in DDDR or DDD mode at 60 min^{-1} , 2.5 V, 0.4 ms.

^b Current consumption when at the Beginning of Service in DDDR or DDD mode at 60 min^{-1} , 2.5 V, 0.4 ms.

17.2.3 Variation with temperature

Basic rate, test pulse rate, pulse duration, and pulse amplitude remain within expected tolerances when the device temperature is between 20°C to 43°C . Sensitivity at nominal conditions as measured at 37°C can vary up to $\pm 1\%$ per $^{\circ}\text{C}$, from 22°C to 45°C .

17.2.4 Projected service life: Model G70A2

Table 7. Model G70A2 Projected service life from implant to RRT in years

Pacing	A Amplitude, V Amplitude	Rate, Pulse Width	Lead impedance	
			500 Ω	1000 Ω
			Longevity (years)	
DDDR or DDD, 0%	1.5 V, 2.0 V ^a	60 min^{-1} , 0.4 ms	12.8	12.8
	2.5 V, 2.5 V		11.9	11.9
	3.5 V, 3.5 V		12.5	12.5
DDDR or DDD, 50%	1.5 V, 2.0 V ^a	60 min^{-1} , 0.4 ms	11.4	12.0
	2.5 V, 2.5 V		10.2	11.0
	3.5 V, 3.5 V		9.1	10.4
DDDR or DDD, 100%	1.5 V, 2.0 V ^a	60 min^{-1} , 0.4 ms	10.2	11.3
	2.5 V, 2.5 V		9.0	10.2
	3.5 V, 3.5 V		7.1	8.9
DDDR or DDD, 0%	2.5 V, 2.5 V	70 min^{-1} , 0.5 ms	11.8	—
	5.0 V, 5.0 V		11.5	—
DDDR or DDD, 100%	2.5 V, 2.5 V	70 min^{-1} , 0.5 ms	7.9	—
	5.0 V, 5.0 V		3.8	—
DDDR or DDD, 100%	5.0 V, 5.0 V	70 min^{-1} , 1.0 ms	2.5	—
DDDR or DDD, 100%	5.0 V, 5.0 V	100 min^{-1} , 1.0 ms	1.8	—

^a For ACM, the Minimum Adapted Amplitude is 1.5 V (nominal). For VCM, the Minimum Adapted Amplitude is 2.0 V (nominal).

17.2.5 Prolonged service period

At most programmed settings, approximately 95% of pacemakers have a prolonged service period of at least 90 days between RRT and ERI, and 90 days between ERI and EOS.

The prolonged service period between RRT and EOS meet the following conditions, in conformance with ISO 14708-2:

- 100% pacing in DDD mode
- 60 min⁻¹ pacing rate
- 2.5 V atrial amplitude / 0.4 ms atrial pulse width
- 2.5 V ventricular amplitude / 0.4 ms ventricular pulse width
- 600 Ω pacing load

The mean prolonged service period is 203 days.

Note: After ERI, pacing parameters including mode and rate can be reprogrammed, however this may shorten the ERI-to-EOS period.

17.2.6 Features disabled at RRT

The following features are disabled at RRT and cannot be programmed to On:

- MRI SureScan mode
- EP Studies

17.2.7 Features disabled at ERI

The following features are disabled at ERI and cannot be programmed to On:

- Single Chamber Hysteresis
- Sleep function
- Ventricular Output Management
- Atrial Sensing Assurance
- Ventricular Sensing Assurance

17.3 Magnet operation and Elective Replacement Indicator (ERI)

Table 8. Magnet operation and Elective Replacement Indicator (ERI) status

Magnet operation		Indicators of ERI status	
Without magnet	With magnet	Without magnet	With magnet
DDDR/DDD	DOO at 85 min ⁻¹ (705 ms / ±2 min ⁻¹)	VVI at 65 min ⁻¹	VOO at 65 min ⁻¹ (923 ms / ±2 min ⁻¹)
VDD	VOO at 85 min ⁻¹ (705 ms / ±2 min ⁻¹)	VVI at 65 min ⁻¹	VOO at 65 min ⁻¹ (923 ms / ±2 min ⁻¹)
VVI/AAI	VOO/AOO at 85 min ⁻¹ (705 ms / ±2 min ⁻¹)	VVI at 65 min ⁻¹	VOO at 65 min ⁻¹ (923 ms / ±2 min ⁻¹)

Note: The device does not respond to the application of a magnet for one hour after the use of a programmer unless the session is ended with the command option to immediately clear data collected in the device. The default command for ending a session allows the device to retain collected data for one hour.

17.4 Measuring methods

Device parameters, such as pulse duration, pulse amplitude, and sensitivity (sensing threshold), are measured according to the standard ISO 14708-2 or EN 45502-2-1.

Pulse duration – Pulse duration is measured at 1/3 peak voltage levels according to the standard ISO 14708-2 or EN 45502-2-1. See *Figure 8*. When applying this measurement method at a 240 Ω load, the tolerance for pulse width 0.12 ms and 0.15 ms is ± 10 μs, from 0.21 ms and 1.25 ms is ± 25 μs, and for 1.50 ms is +0/-224 μs. When

applying this measurement method at a 500 or 1000 Ω load, the tolerance for pulse width 0.12 ms and 0.15 ms is $\pm 10 \mu\text{s}$, and from 0.21 ms through 1.50 ms is $\pm 25 \mu\text{s}$. When applying this measurement method at a 2000 Ω load, the tolerance for pulse width 0.12 ms and 0.15 ms is $+20/-10 \mu\text{s}$, and from 0.21 ms through 1.50 ms is $+35/-25 \mu\text{s}$.

Pulse amplitude – The pulse amplitude is measured according to the standard ISO 14708-2 or EN 45502-2-1. See *Figure 9*. When applying this measurement method at a 240 Ω load, the tolerance for pulse amplitude is $+0\%/-20\%$, and at a 500 Ω load, the tolerance for pulse amplitude is $\pm 10\%$. When applying this measurement method at a 1000 Ω load, the tolerance for pulse amplitude is $+14\%/-6\%$, and at a 2000 Ω load, the tolerance for pulse amplitude is $+16\%/-4\%$.

Sensitivity (sensing threshold) – Ventricular sensitivity is defined as the voltage amplitude of a standard ISO 14708-2 or EN 45502-2-1 test signal that is just sufficient to be sensed by the device. The signal from a test signal generator used for the exact determination of sensitivity (sensing threshold) is illustrated in *Figure 10*.

Notes:

- When measuring the pacing and sensing parameters with pacing system analyzers, considerable differences may be observed with the specifications presented in this manual. This is because the measuring methods employed by such systems may differ from those described above.
- Lead impedance measurement results may be distorted by electrocardiogram monitoring equipment.

Figure 8. Measurement of pulse duration

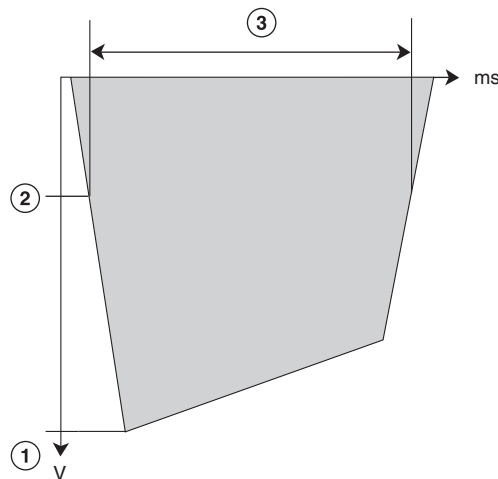

1 Maximum amplitude
2 1/3 maximum amplitude

3 Pulse duration

Figure 9. Measurement of pulse amplitude

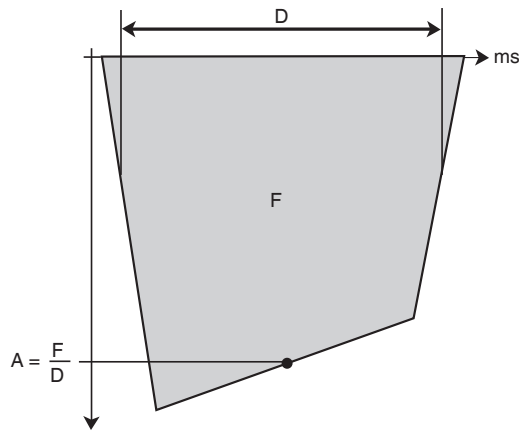
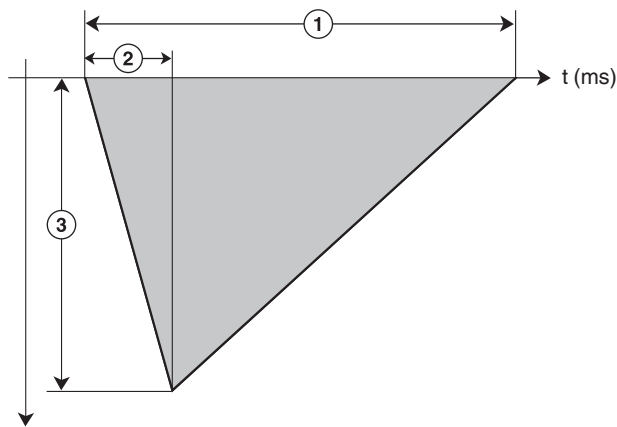

Figure 10. Measurement of sensitivity



1 $T = 15 \text{ ms} \pm 1 \text{ ms}$

2 $t = 2 \text{ ms} \pm 0.2 \text{ ms}$

3 Signal amplitude A_T

Note: The signal may be either positive or negative.

18 Device parameters

18.1 Shipping, nominal, and electrical reset parameters

Notes:

- “Unchanged” indicates that the programmed setting is unaffected by nominal programming or an electrical reset event. “Adaptive” indicates that the parameter is adapted during operation.
- The shipping parameters for some features are not applied until the 30-minute Implant Detection period is complete.
- After certain serious device errors, the pacemaker will recover as a single chamber, non-rate response device. If this occurs, contact a Vitatron representative.

Table 9. Mode and rates

Parameter	Shipping	Nominal	Partial electrical reset	Full electrical reset
Mode and rates				
Mode	DDDR	DDDR	Unchanged	VVI
Mode Switch	On	On	Unchanged	Off
Detect Rate	175 min ⁻¹	175 min ⁻¹	175 min ⁻¹	175 min ⁻¹
Detect Duration	No Delay	No Delay	No Delay	No Delay
Blanked Flutter Search	On	On	Unchanged	On
Lower Rate	60 min ⁻¹ (1000 ms ±17 ms)	60 min ⁻¹ (1000 ms ±17 ms)	Unchanged	65 min ⁻¹ (923 ms)
Upper Tracking Rate	130 min ⁻¹	130 min ⁻¹	Unchanged	120 min ⁻¹
Upper Sensor Rate	130 min ⁻¹	130 min ⁻¹	Unchanged	120 min ⁻¹

Table 10. Rate Response

Parameter	Shipping	Nominal	Partial electrical reset	Full electrical reset
ADL Rate	95 min ⁻¹	95 min ⁻¹	Unchanged	95 min ⁻¹
Rate Profile Optimization	On	On	Unchanged	Off
ADL Response	3	3	3	3
Exertion Response	3	3	3	3
ADL Setpoint	15	Unchanged	15	15
UR Setpoint	40	Unchanged	40	40
Activity Threshold	Medium/Low	Unchanged	Medium/Low	Medium/Low
Acceleration	30 s	Unchanged	30 s	30 s
Deceleration	Exercise	Unchanged	Exercise	Exercise

Table 11. Atrial Lead

Parameter	Shipping	Nominal	Partial electrical reset	Full electrical reset
Amplitude	3.5 V (Adaptive)	3.5 V (Adaptive) ^a	Unchanged	5.0 V
Pulse Width	0.4 ms (Adaptive)	0.4 ms (Adaptive) ^a	Unchanged	0.4 ms
Sensitivity	0.5 mV (Adaptive)	0.5 mV (Adaptive) ^a	Unchanged	0.5 mV
Sensing Assurance	On	On	Unchanged	Off
Pace Polarity	Configure	Unchanged	Unchanged	Configure ^b
Sense Polarity	Configure	Unchanged	Unchanged	Configure ^b
Lead Monitor	Configure	Unchanged	Unchanged	Configure
Notify if <	200 Ω	200 Ω	200 Ω	200 Ω
Notify if >	4000 Ω	4000 Ω	4000 Ω	4000 Ω
Monitor Sensitivity	8	8	8	8

^a Value from which adaptive adjustment begins when nominals are programmed.

^b Bipolar models revert to Implant Detection during which polarity is automatically configured.

Table 12. Ventricular lead

Parameter	Shipping	Nominal	Partial electrical reset	Full electrical reset
Amplitude	3.5 V (Adaptive)	3.5 V (Adaptive) ^a	Unchanged	5.0 V
Pulse Width	0.4 ms (Adaptive)	0.4 ms (Adaptive) ^a	Unchanged	0.4 ms
Sensitivity	2.8 mV (Adaptive)	2.8 mV (Adaptive) ^a	Unchanged	2.8 mV
Sensing Assurance	On	On	Unchanged	Off
Pace Polarity	Configure	Unchanged	Unchanged	Configure ^b
Sense Polarity	Configure	Unchanged	Unchanged	Configure ^b
Lead Monitor	Configure	Unchanged	Unchanged	Configure
Notify if <	200 Ω	200 Ω	200 Ω	200 Ω
Notify if >	4000 Ω	4000 Ω	4000 Ω	4000 Ω
Monitor Sensitivity	8	8	8	8

^a Value from which adaptive adjustment begins when nominals are programmed.

^b Bipolar models revert to Implant Detection during which polarity is automatically configured.

Table 13. Atrial Output Management

Parameter	Shipping	Nominal	Partial electrical reset	Full electrical reset
Atrial Output Management	Adaptive	Adaptive	Unchanged	Off
Amplitude Margin	2x (times)	2x (times)	Unchanged	2x (times)
Minimum Adapted Amplitude	1.5 V	1.5 V	Unchanged	1.5 V
Capture Test Frequency	Day at...	Day at...	Day at...	Day at...
Capture Test Time	01:00:00	01:00:00	01:00:00	01:00:00
Acute Phase Days Remaining	112 days	Unchanged	Unchanged	112 days

Table 14. Ventricular Output Management

Parameter	Shipping	Nominal	Partial electrical reset	Full electrical reset
Ventricular Output Management	Adaptive	Adaptive	Unchanged	Off
Amplitude Margin	2x (times)	2x (times)	Unchanged	2x (times)
Minimum Adapted Amplitude	2.0 V	2.0 V	Unchanged	2.0 V
Capture Test Frequency	Day at Rest	Day at Rest	Day at Rest ^a	Day at Rest
Capture Test Time	None	None	None ^a	None

Table 14. Ventricular Output Management (continued)

Parameter	Shipping	Nominal	Partial electrical reset	Full electrical reset
Acute Phase Days Remaining	112 days	Unchanged	112 days	112 days
V. Sensing During Search	Adaptive	Adaptive	Adaptive	Adaptive

^a If values differ from nominal, the Capture Test Time will be set to occur every Day at...12 hours after electrical reset time.

Table 15. Intrinsic Activation and AV Intervals

Parameter	Shipping	Nominal	Partial electrical reset	Full electrical reset
Paced AV (PAV)	150 ms	150 ms ^a	150 ms ^b	150 ms
Sensed AV (SAV)	120 ms	120 ms ^a	120 ms ^b	120 ms
RAAV	Off	Off	Unchanged	Off
Start Rate	80 min ⁻¹	80 min ⁻¹	80 min ⁻¹	80 min ⁻¹
Stop Rate	120 min ⁻¹	120 min ⁻¹	120 min ⁻¹	120 min ⁻¹
Maximum Offset	-40 ms	-40 ms	-40 ms	-40 ms
Reduced VP+ ^c	On	On	Unchanged	Off
Max Increase to AV	170 ms	170 ms	Unchanged	110 ms
Sinus Preference	On	On	Unchanged	Off
Sinus Preference Zone	10 min ⁻¹	10 min ⁻¹	10 min ⁻¹	10 min ⁻¹
Search Interval	10 min	10 min	10 min	10 min

^a Value from which adaptive adjustment begins when nominals are programmed.

^b Reset value from which adaptive adjustment begins if Reduced VP+ is On at a partial reset.

^c Reduced VP™ is a trademark of Vitatron Holding B.V.

Table 16. Refractory/Blanking

Parameter	Shipping	Nominal	Partial electrical reset	Full electrical reset
PVARP	Auto	Auto	Unchanged	310 ms ^a
Minimum PVARP	250 ms	250 ms	Unchanged	None
PVAB	180 ms	180 ms	180 ms	180 ms
Atrial Refractory Period ^b	250 ms	250 ms	Unchanged	310 ms
Atrial Blanking Period ^b	180 ms	180 ms	180 ms	180 ms
Ventricular Refractory Period	230 ms	230 ms	230 ms	230 ms
Ventricular Blanking Period (after atrial pace) (PAVB)	28 ms	28 ms	28 ms	28 ms

^a Sensor varied PVARP and automatic PVARP are disabled at full electrical reset.

^b Atrial modes only.

Table 17. Additional features

Parameter	Shipping	Nominal	Partial electrical reset	Full electrical reset
Sleep Function	Off	Off	Off	Off
Sleep Rate	50 min ⁻¹	50 min ⁻¹	50 min ⁻¹	50 min ⁻¹
Bed Time	22:00:00	22:00:00	22:00:00	22:00:00
Wake Time	08:00:00	08:00:00	08:00:00	08:00:00
Non-Competitive Atrial Pacing	On	On	Unchanged	Off
Single Chamber Hysteresis	Off	Unchanged	Unchanged	Off
Rate Drop Response				
Detection Type	Off	Off	Unchanged	Off
Intervention Rate	100 min ⁻¹	100 min ⁻¹	Unchanged	100 min ⁻¹
Intervention Duration	2 min	2 min	Unchanged	2 min
Detection Beats	2 beats	2 beats	2 beats	2 beats
Drop Rate	50 min ⁻¹	50 min ⁻¹	Unchanged	50 min ⁻¹
Drop Size	25 min ⁻¹	25 min ⁻¹	25 min ⁻¹	25 min ⁻¹
Detection Window	25 s	25 s	25 s	25 s
PMT Intervention	Off	Off	Unchanged	Off
PVC Response	On	On	Unchanged	On
Ventricular Safety Pacing	On	On	Unchanged	On
Implant Detection	On/Restart	Unchanged	Unchanged	On/Restart

Table 18. Interventions

Parameter	Shipping	Nominal	Partial electrical reset	Full electrical reset
Post Mode Switch Pacing	Off	Off	Unchanged	Off
Overdrive Period	10 min	10 min	Unchanged	10 min
Overdrive Rate	80 min ⁻¹	80 min ⁻¹	Unchanged	80 min ⁻¹
Atrial Preference Pacing	Off	Off	Unchanged	Off
Maximum Rate	100 min ⁻¹	100 min ⁻¹	100 min ⁻¹	100 min ⁻¹
Interval Decrement	30 ms	30 ms	30 ms	30 ms
Search Beats	20	20	20	20
Conducted AF Response	Off	Off	Unchanged	Off
Maximum Rate	110 min ⁻¹	110 min ⁻¹	110 min ⁻¹	110 min ⁻¹

Table 19. MRI SureScan

Parameter	Shipping	Nominal	Partial electrical reset	Full electrical reset
MRI SureScan	Off	Off	Off ^a	Off ^a

^a This parameter cannot be programmed nor it is visible until the reset has been cleared.

Table 20. Telemetry features

Parameter	Shipping	Nominal	Partial electrical reset	Full electrical reset
Transtelephonic Monitor	Off	Unchanged	Unchanged	Off
Extended Telemetry	Off	Unchanged	Off	Off
Extended Marker	Standard	Unchanged	Standard	Standard

18.2 Programmable parameters

Caution: Do not program device parameters before implant. Do not program Rate Response until after Implant Detection is complete.

Note: In the event of a component failure, the limits for atrial and ventricular rates are held independently to an upper rate limit. This rate limit is automatically disabled with high rate temporary modes. The atrial and ventricular Rate Limit is 200 min^{-1} ($\pm 20 \text{ min}^{-1}$).

Table 21. Mode and rates

Parameter	Settings	Notes
Mode	DDDR; DDIR; DVIR; DOOR; DDD; VDD; DDI; DVI; DOO; VVIR; VVI; VVT; VOOR; VOO; AAIR; AAI; AAT; AOOR; AOO; VDIR; VDI; ADIR; ADI; ODO; OVO; OAO	
Mode Switch	On; Off	
Detect Rate	120; 125; 130 ... 200 min^{-1} ($\pm 3 \text{ min}^{-1}$)	
Detect Duration	No Delay; 10; 20 ... 60 s	
Blanked Flutter Search	On; Off	
Lower Rate ^{a,b}	30; 35; 40 ... 120 min^{-1} (except 65 and 85 min^{-1}) ($\pm 1 \text{ min}^{-1}$) 125; 130; 135 ... 170 min^{-1} ($\pm 2 \text{ min}^{-1}$)	
Upper Tracking Rate	80; 90; 95 ... 180 min^{-1} ($\pm 2 \text{ min}^{-1}$)	
Upper Sensor Rate	80; 90; 95; 100 ... 180 min^{-1} ($\pm 2 \text{ min}^{-1}$)	

^a The corresponding pacing interval or escape interval can be calculated as follows: interval (in ms) = $60000 / \text{Lower Rate}$ (in min^{-1}).

^b The tolerance for the escape interval is ± 22 ms when the Lower Rate is 30 min^{-1} and $+25/-10$ ms for all other Lower Rate settings.

Table 22. Rate Response

Parameter	Settings	Notes
ADL Rate	60; 65; 70 ... 120 min^{-1} ($\pm 1 \text{ min}^{-1}$) 125; 130; 135 ... 175 min^{-1} ($\pm 2 \text{ min}^{-1}$)	
Rate Profile Optimization	On; Off	
ADL Response	1; 2; 3; 4; 5	
Exertion Response	1; 2; 3; 4; 5	
ADL Setpoint	5; 6; 7 ... 40; 42; 44; 46 ... 80	Programmable from the Exercise test only
UR Setpoint	15; 16; 17 ... 40; 42; 44; 46 ... 80; 85; 90; 95 ... 180	Programmable from the Exercise test only
Activity Threshold	Low; Medium/Low; Medium/High; High	

Table 22. Rate Response (continued)

Parameter	Settings	Notes
Acceleration	15 s (+8/–2 s); 30 s (+13/–3 s); 60 s(+19/–3 s)	
Deceleration	2.5 min (+0.6/–0.2 min); 5 min (+1.1/–0.5 min); 10 min (+1.1/–1.0 min); Exercise	

Table 23. Atrial Lead

Parameter	Settings	Notes
Amplitude ^a (with Atrial Output Management)	0.5; 0.75; 1.0 ... 4.0; 4.5; 5.0 V	0.625, 0.875, 1.125, 1.375, 1.625, and 1.875 V can be set by Output Management. Values are displayed but are not selectable.
Amplitude ^a (without Atrial Output Management)	0.5; 0.75; 1.0 ... 4.0; 4.5; 5.0; 5.5; 6.0; 7.5 V	
Pulse Width ^a (with Atrial Output Management)	0.12; 0.15; 0.21; 0.27; 0.34; 0.40; 0.46; 0.52; 0.64; 0.76; 1.00 ms	Settings lower than 0.40 ms can be programmed, but Output Management adjusts them to 0.40 ms.
Pulse Width ^a (without Atrial Output Management)	0.12; 0.15; 0.21; 0.27; 0.34; 0.40; 0.46; 0.52; 0.64; 0.76; 1.00; 1.25; 1.50 ms	
Sensitivity ^b	0.18; 0.25; 0.35 mV (±60%) 0.5; 0.7; 1.0; 1.4; 2.0; 2.8; 4.0 mV (±40%)	0.18, 0.25, and 0.35 mV apply to bipolar atrial sensing only.
Sensing Assurance	On; Off	
Pace Polarity	Bipolar; Unipolar; Configure	Configure is displayed but is not selectable.
Sense Polarity	Bipolar; Unipolar; Configure	Configure is displayed but is not selectable.
Lead Monitor	Off; Configure; Monitor Only; Adaptive	
Notify if < (less than)	200 Ω	Non-programmable.
Notify if > (greater than)	1000; 2000; 3000; 4000 Ω	
Monitor Sensitivity	2; 3; 4 ... 16	

^a The tolerance for measurements performed per ISO 14708-2 or EN 45502-2-1 is listed in *Section 17.4*.

^b **Warning:** Carefully evaluate the possibility of increased susceptibility to EMI and oversensing before changing the sensitivity from its nominal setting to a more sensitive setting. When susceptibility to interference is tested under the conditions specified in ISO 14708-2, ISO 14117, or EN 45502-2-1, the device is more susceptible to electromagnetic interference. The device meets standard requirements when the unipolar sensitivity threshold is programmed to 2.8 mV or higher, the bipolar ventricular sensitivity threshold is programmed to 1.0 mV or higher, or the bipolar atrial sensitivity threshold is programmed to 0.35 mV or higher.

Table 24. Ventricular Lead

Parameter	Settings	Notes
Amplitude ^a (with Ventricular Output Management)	0.5; 0.75; 1.0 ... 4.0; 4.5; 5.0 V	0.625, 0.875, 1.125, 1.375, 1.625, and 1.875 V can be set by Ventricular Output Management. Values are displayed but are not selectable.
Amplitude ^a (without Ventricular Output Management)	0.5; 0.75; 1.0 ... 4.0; 4.5; 5.0; 5.5; 6.0; 7.5 V	

Table 24. Ventricular Lead (continued)

Parameter	Settings	Notes
Pulse Width ^a (with Ventricular Output Management)	0.12; 0.15; 0.21; 0.27; 0.34; 0.40; 0.46; 0.52; 0.64; 0.76; 1.00 ms	Settings lower than 0.40 ms can be programmed, but Output Management adjusts them to 0.40 ms.
Pulse Width ^a (without Ventricular Output Management)	0.12; 0.15; 0.21; 0.27; 0.34; 0.40; 0.46; 0.52; 0.64; 0.76; 1.00; 1.25; 1.50 ms	
Sensitivity ^b	1.0; 1.4; 2.0; 2.8; 4.0; 5.6; 8.0; 11.2 mV (±40%)	
Sensing Assurance	On; Off	
Pace Polarity	Bipolar; Unipolar; Configure	Configure is displayed but is not selectable.
Sense Polarity	Bipolar; Unipolar; Configure	Configure is displayed but is not selectable.
Lead Monitor	Off; Configure; Monitor Only; Adaptive	
Notify if < (less than)	200 Ω	Non-programmable.
Notify if > (greater than)	1000; 2000; 3000; 4000 Ω	
Monitor Sensitivity	2; 3; 4 ... 16	

^a The tolerance for measurements performed per ISO 14708-2 or EN 45502-2-1 is listed in *Section 17.4*.

^b **Warning:** Carefully evaluate the possibility of increased susceptibility to EMI and oversensing before changing the sensitivity from its nominal setting to a more sensitive setting. When susceptibility to interference is tested under the conditions specified in ISO 14708-2, ISO 14117, or EN 45502-2-1, the device is more susceptible to electromagnetic interference. The device meets standard requirements when the unipolar sensitivity threshold is programmed to 2.8 mV or higher, the bipolar ventricular sensitivity threshold is programmed to 1.0 mV or higher, or the bipolar atrial sensitivity threshold is programmed to 0.35 mV or higher.

Table 25. Atrial Output Management

Parameter	Settings	Notes
Atrial Output Management	Off; Monitor Only; Adaptive	
Amplitude Margin	1.5x; 2x; 2.5x; 3x; 4x (times)	
Minimum Adapted Amplitude	0.5; 0.75; 1.0 ... 3.5 V	
Capture Test Frequency	1; 2; 4; 8; 12 hours; Day at rest; Day at ...; 7 Days at ...	For Day(s) at ..., next parameter specifies the time of day.
Capture Test Time	00:00:00; 01:00:00 ... 23:00:00	Applies only for Day(s) at ...parameter.
Acute Phase Days Remaining ^a	Off; 7; 14 ... 84; 112; 140; 168; 196; 224; 252 days	

^a If the acute phase is completed, the time and date of completion are indicated below Acute Phase Days Remaining.

Table 26. Ventricular Output Management

Parameter	Settings	Notes
Ventricular Output Management	Off; Monitor Only; Adaptive	
Amplitude Margin	1.5x; 2x; 2.5x; 3x; 4x (times)	
Minimum Adapted Amplitude	0.5; 0.75; 1.0 ... 3.5 V	

Table 26. Ventricular Output Management (continued)

Parameter	Settings	Notes
Capture Test Frequency	15; 30 min; 1; 2; 4; 8; 12 hours; Day at rest; Day at ...; 7 Days at ...	For Day(s) at ..., next parameter specifies the time of day.
Capture Test Time	00:00:00; 01:00:00 ... 23:00:00	Applies only for Day(s) at ... parameter.
Acute Phase Days Remaining ^a	Off; 7; 14 ... 84; 112; 140; 168; 196; 224; 252 days	
V. Sensing during Search	Unipolar; Bipolar; Adaptive	

^a If the acute phase is completed, the time and date of completion are indicated below Acute Phase Days Remaining.

Table 27. Intrinsic Activation and AV Intervals

Parameter	Settings	Notes
Paced AV (PAV)	30; 40; 50 ... 350 ms (± 4 ms)	
Sensed AV (SAV)	30; 40; 50 ... 350 ms ($+16/-4$ ms)	
RAAV	On; Off	
Start Rate	50; 55; 60 ... 175 min ⁻¹ (± 5 min ⁻¹)	
Stop Rate	55; 60; 65 ... 180 min ⁻¹ (± 5 min ⁻¹)	
Maximum Offset	-10; -20; -30 ... -300 ms	
Reduced VP+	On; Off	
Max Increase to AV	10; 20; 30 ... 250 ms	
Sinus Preference	On; Off	
Sinus Preference Zone	3; 5; 10; 15; 20 min ⁻¹	
Search Interval	5; 10; 20; 30 min	

Table 28. Refractory/Blanking

Parameter	Settings	Notes
PVARP	Auto; Varied; 150; 160; 170 ... 500 ms (± 9 ms)	
Minimum PVARP	150; 160; 170 ... 500 ms (± 9 ms)	Auto PVARP only.
PVAB	130; 140; 150 ... 350 ms (± 9 ms)	Blanking for PVARP.
Ventricular Refractory Period	150; 160; 170 ... 500 ms (± 9 ms)	
Atrial Refractory Period ^a	180; 190; 200 ... 500 ms (± 9 ms)	
Ventricular Blanking Period	20; 28; 36; 44 ms ($+0/-15$ ms)	After atrial pace.
Atrial Blanking Period ^a	130; 140; 150 ... 350 ms (± 9 ms)	

^a Atrial modes only.

Table 29. Additional features

Parameter	Settings	Notes
Sleep Function	On; Off	
Sleep Rate	30; 35; 40 ... 90 min ⁻¹ (except 65 and 85 min ⁻¹) (± 1 min ⁻¹)	

Table 29. Additional features (continued)

Parameter	Settings	Notes
Bed Time	00:00:00; 00:15:00; 00:30:00 ... 23:45:00 (± 10 min)	
Wake Time	00:00:00; 00:15:00; 00:30:00 ... 23:45:00 (± 10 min)	
Non-Competitive Atrial Pacing	On; Off	
Single Chamber Hysteresis	Off; 40; 50; 60 min^{-1} (± 1 min^{-1})	
Rate Drop Response		
Detection Type	Off; Low Rate; Drop; Both	
Intervention Rate	60; 70; 75 ... 120 min^{-1} (± 1 min^{-1}) 125; 130; 135 ... 180 min^{-1} (except 65 and 85 min^{-1}) (± 2 min^{-1})	
Intervention Duration	1; 2; 3 ... 15 min	
Detection Beats	1; 2; 3 beats	
Drop Rate	30; 40; 50 ... 100 min^{-1} (± 1 min^{-1})	
Drop Size	10; 15; 20 ... 50 min^{-1} (± 2 min^{-1})	
Detection Window	10; 15; 20 ... 30 s 1; 1.5; 2; 2.5 min	
PMT Intervention	On; Off	
PVC Response	On; Off	
Ventricular Safety Pacing	On; Off	
Implant Detection	On/Restart; Off/Complete ^a	

^a If Implant Detection is completed, the time and date of completion are indicated below the Off/Complete setting.

Table 30. Interventions

Parameter	Settings	Notes
Post Mode Switch Pacing	On; Off	
Overdrive Period	0.5; 1; 2; 3; 5; 10; 20; 30; 60; 90; 120 min	
Overdrive Rate	70; 75; 80; 90; 95; 100 ... 120 min^{-1} (excluding 85 min^{-1} for magnet operation)	
Atrial Preference Pacing	On; Off	
Maximum Rate	80, 90, 95, 100 ... 150 min^{-1}	
Interval Decrement	30, 40, 50 ... 100, 150 ms	
Search Beats	5, 10, 15, 20, 25, 50	
Conducted AF Response	On; Off	Continuously in DDIR, VDIR, or VVIR modes, or during mode switching.
Maximum Rate	80; 85; 90; 95 ... 130 min^{-1} (± 2 min^{-1})	

Table 31. MRI SureScan parameters

Parameter	Settings	Notes
MRI SureScan	On; Off	
MRI Pacing Mode	DOO; AOO; VOO; ODO	
MRI Pacing Rate	60; 70; 75; 80; 90; 95 ... 120 min ⁻¹	

Table 32. Telemetry Features

Parameter	Settings	Notes
Transtelephonic Monitor	On; Off	
Extended Telemetry	On; Off	
Extended Marker ^a	Standard; Therapy Trace	

^a Therapy Trace markers cannot be displayed or printed on the programmer.

Table 33. Status (reset) parameters

Parameter	Settings	Notes
Atrial Lead Status	Reset Indicator	
Ventricular Lead Status	Reset Indicator	
RRT/ERI or POR Reset	Reset	Listed under Additional Features

Table 34. Temporary parameters

Parameter	Settings	Notes
Chamber	Atrium; Ventricle	Setting determines available modes.
Mode	DDD; DDI; DOO; VDD; VDI; VVI; VVT; VOO; AAI; ADI; AAT; AOO; ODO; OVO; OAO	Availability of modes is dependent on programmed mode.
Lower Rate	30; 35; 40 ... 120 min ⁻¹ (except 65 and 85 min ⁻¹) (±1 min ⁻¹) 125; 130; 135 ... 180 min ⁻¹ (±2 min ⁻¹) 190; 200; 210 ... 250 min ⁻¹ (±3 min ⁻¹) 260; 270; 280; 300; 310; 320; 330; 350; 370; 380; 400 min ⁻¹ (±5 min ⁻¹)	Rates above 180 min ⁻¹ are available by selecting the enable button.
Amplitude ^{a,b}	0.25; 0.375 ... 2.0; 2.25; 2.50; 2.75 ... 4.0; 4.5; 5.0; 5.5; 6.0; 7.5 V	
Pulse Width ^b	0.03; 0.06; 0.09 ... 0.15; 0.21; 0.27; 0.34; 0.40; 0.46; 0.52; 0.64; 0.76; 1.00; 1.25; 1.50 ms	
Atrial Sensitivity	0.18; 0.25; 0.35 mV (±60%) 0.5; 0.7; 1.0; 1.4; 2.0; 2.8; 4.0 mV (±40%)	
Ventricular Sensitivity	1.0; 1.4; 2.0; 2.8; 4.0; 5.6; 8.0; 11.2 mV (±40%)	
AV Delay	30; 40; 50 ... 350 ms (±4 ms)	Selection sets PAV and SAV if pertinent to mode.

^a The amplitude values in 0.125 V increments apply only to the Output Management and Temporary test.

^b The tolerance for measurements performed per ISO 14708-2 or EN 45502-2-1 is listed in *Section 17.4*.

18.3 Automatic and clinician-selectable diagnostics

Table 35. Automatic Diagnostics

Parameter	Settings
Heart Rate Histograms ^a (Short and Long Term, Atrial and Ventricular)	
Include Refractory Senses	Include; Exclude
AV Conduction Histograms (Short and Long Term)	
Reduced VP+ Histogram	
Sensor Indicated Rate Profile	
Atrial High Rate Episodes (Mode Switch On)	
Collection Delay after Mode Switch	0; 1; 2 ... 20; 25; 30 ... 60 s
Collection Method ^b	Frozen; Rolling
Atrial High Rate Episodes (Mode Switch Off)	
Detection Rate	80; 85; 90 ... 180; 200; 220; 240 ... 320; 330; 350; 370; 380; 400 min ⁻¹
Detection Duration	1; 2; 3 ... 20; 25; 30 ... 50; 55; 60 s
Termination Beats	5; 6; 7 ... 20 beats
Collection Method ^b	Frozen; Rolling
Ventricular High Rate Episodes	
Detection Rate	80; 85; 90 ... 180; 200; 220; 240 ... 320; 330; 350; 370; 380; 400 min ⁻¹
Detection Duration	2; 3; 4 ... 198; 199; 200 beats
Termination Beats	5; 6; 7 ... 20 beats
SVT Filter	Off; On
Collection Method ^b	Frozen; Rolling
AT/AF Trend	
AT/AF Durations	
Ventricular Rate during AT/AF	
Rate Drop Response Episodes	Based on programmed therapy
Chronic Lead Trends	
Lead Monitor Counters	
Sensitivity Trends	Monitors chambers with Sensing Assurance
Output Management Trend	Based on use of Output Management
Atrial Output Management	
Ventricular Output Management	
Key Parameter History	

^a Heart Rate Histograms can be programmed to include or exclude refractory sensed events.

^b Collection Method applies to Atrial High Rate Episodes and Ventricular High Rate Episodes.

Table 36. Clinician-Selectable Diagnostics

Diagnostic and parameters	Parameter settings
Custom Rate Trend	
Duration	Beat-to-Beat; 1 Hour; 24 hours
Collection Method	Frozen; Rolling

Table 36. Clinician-Selectable Diagnostics (continued)

Diagnostic and parameters	Parameter settings
Include Refractory Senses	Include; Exclude
Ventricular Output Management Detail	
EGM Collection	Off; Atrial EGM; Ventricular EGM; Summed EGM
Atrial Output Management Detail	
EGM Collection	Off; Atrial EGM; Ventricular EGM; Summed EGM
High Rate Detail^a	
High Rate Type	AHR and VHR; AHR; VHR
EGM Type	Off; Atrial EGM; Ventricular EGM; Summed EGM
Allocation (Collection Method ^b = Frozen, High Rate Type = AHR and VHR)	2 for 0/24; 2 for 24/0; 2 for 12/12; 4 for 0/12; 4 for 12/0; 4 for 6/6; 8 for 0/6; 8 for 6/0; 8 for 3/3 (number of episodes for pre-onset seconds/post onset seconds collected)
Allocation (Collection Method ^b = Frozen, High Rate Type = AHR only or VHR only)	1 for 0/48; 1 for 48/0; 1 for 24/24; 2 for 0/24; 2 for 24/0; 2 for 12/12; 4 for 0/12; 4 for 12/0; 4 for 6/6; 8 for 0/6; 8 for 6/0; 8 for 3/3 (number of episodes for pre-onset seconds/post onset seconds collected)
Allocation (Collection Method ^b = Rolling, High Rate Type = AHR and VHR)	2 for 16/0; 2 for 8/8; 2 for 0/24; 4 for 8/0; 4 for 4/4; 4 for 0/12; 8 for 4/0; 8 for 2/2; 8 for 0/6 (number of episodes for pre-onset seconds/post onset seconds collected)
Allocation (Collection Method ^b = Rolling, High Rate Type = AHR only or VHR only)	1 for 24/0; 1 for 12/12; 1 for 0/48; 2 for 16/0; 2 for 8/8; 2 for 0/24; 4 for 8/0; 4 for 4/4; 4 for 0/12; 8 for 4/0; 8 for 2/2; 8 for 0/6 (number of episodes for pre-onset seconds/post onset seconds collected)
Pre-detection Timeout	1; 2; 3 ... 12; 14; 16 ... 24 weeks
Rate Drop Response Detail	
Include Refractory Senses	Include; Exclude

^a High rate detection rate, detection duration, and termination criteria are set by parameters for the automatic diagnostic.

^b Collection Method is set in the High Rate automatic diagnostic.

18.4 Nonprogrammable parameters

Table 37. Nonprogrammable parameters

Parameter	Value
Magnet rate	
Magnet rate	85 min ⁻¹ (± 2 min ⁻¹)
Magnet rate at ERI	65 min ⁻¹ (± 2 min ⁻¹)
Hardware parameters	
Pacing rate limit (protective feature)	200 min ⁻¹ (± 30 min ⁻¹)
Input impedance	150 k Ω minimum
Effective pacing capacitance	5 μ F ($\pm 10\%$)

Table 37. Nonprogrammable parameters (continued)

Parameter	Value
Recommended Replacement Time (RRT) and Elective Replacement Indicator (ERI)	
Battery Voltage Threshold	≤ 2.5 V, or ≤ 2.59 V and battery impedance at $\geq 3000 \Omega$
Operating period between RRT and ERI	90 days
Operating period between ERI and End of Service (EOS) ^a	90 days

^a EOS is set when the first pace fails to deliver at programmed pacing parameters because of depleted battery power.

19 Feature summary

This section describes the features available with the G70 DR MRI SureScan model G70A2 pacemaker.

Atrial Output Management – This feature monitors the atrial pacing threshold with daily pacing threshold searches and, if programmed to do so, adjusts the atrial pacing amplitude toward a target amplitude.

Atrial Preference Pacing (APP) – This feature maintains a consistent activation sequence by providing continuous pacing that is closely matched to the intrinsic rate.

Automatic Polarity Configuration – This feature uses Lead Monitor to automatically configure pacing and sensing polarities for bipolar devices during Implant Detection.

Automatic PVARP – This feature protects against pacemaker-mediated tachycardia (PMT) and provides a higher 2:1 block rate, based on the mean atrial rate. Automatic PVARP enhances protection against PMT by lengthening PVARP at lower tracking rates and provides a higher 2:1 block rate by shortening PVARP and SAV (if necessary) at higher tracking rates.

Conducted AF Response – The feature regularizes the ventricular rhythm during AT/AF by modifying the pacing rate on a beat-by-beat basis to achieve pacing of just over 50% of ventricular events.

EP Studies – EP (Electrophysiologic) Studies uses the patient's implanted pacemaker to noninvasively deliver high-rate cardiac stimulation. Programmable mode, interval, and delay parameters allow set up of protocols to deliver either programmed electrical stimulation (PES) or burst stimulation.

Extended Upper Tracking Rate – When programming Upper Tracking Rates of 190, 200, or 210 min^{-1} , be careful to ensure that these rates are appropriate for the patient. The Upper Tracking Rates of 190, 200, and 210 min^{-1} are intended primarily for use in pediatric patients.

Implant Detection – You can only perform EP Studies when the lead polarities are set to Unipolar or Bipolar. During Implant Detection you can manually configure the lead polarities if you choose, or you can wait for Implant Detection to configure the lead polarities.

Lead Monitor – This feature measures lead impedances during the life of the implanted device and controls automatic configuration of lead polarities at implant. If Lead Monitor is programmed to Adaptive, the device automatically switches bipolar pacing and sensing to unipolar pacing and sensing if the integrity of a bipolar lead is compromised.

Mode Switch – This feature switches the device from a tracking mode to a nontracking mode to prevent rapid ventricular pacing that may result from a high atrial rate, and restores the programmed pacing mode when the atrial tachyarrhythmia ends.

MRI SureScan – This feature allows patients with an implanted MRI SureScan system, including the device and leads, to have a safe MRI procedure if the requirements provided in the MRI technical manual are followed.

Non-Competitive Atrial Pacing (NCAP) – This programmable feature is intended to prevent the triggering of atrial tachycardias by delaying atrial paced events scheduled to occur during the atrial relative refractory period.

Pacemaker-Mediated Tachycardia (PMT) Intervention – This programmable feature provides automatic detection and interruption of PMTs by extending the PVARP for one interval. This ensures that the next atrial event in the PVARP will be refractory.

PMOP (Post Mode Switch Overdrive Pacing) – This atrial intervention feature works with the Mode Switch feature to deliver overdrive atrial pacing during the vulnerable phase following an AT/AF episode termination.

PVC Response – This feature extends PVARP following a premature ventricular contraction (PVC) to avoid tracking a retrograde P-wave and to prevent retrograde conduction from inhibiting an atrial pace.

Rate Adaptive AV (RAAV) – This feature varies the Paced AV (PAV) and Sensed AV (SAV) intervals as the heart rate increases or decreases during dual chamber operation to maintain 1:1 tracking and AV synchrony.

Rate Drop Response – This programmable feature provides backup pacing for patients who experience symptomatic episodes of a significant drop in heart rate. The device intervenes by elevating the pacing rate for a brief period.

Rate Profile Optimization – The goal of Rate Profile Optimization is to ensure that the rate response remains appropriate for the full range of patient activities. This feature monitors the patient's daily and monthly sensor rate profiles and adjusts the rate response curves over time to achieve a prescribed target rate profile.

Rate-responsive pacing – This feature varies the pacing rate in response to the patient's physical motion as detected by the activity sensor of the device.

Rate Response User Interface – This feature provides a graphical display to aid in programming rate response. When Rate Profile Optimization parameters are programmed, rate response undergoes an immediate change.

Reduced VP – This programmable feature searches for the patient's intrinsic AV conduction time and adjusts the Sensed AV (SAV) and the Paced AV (PAV) intervals to promote intrinsic activation of the ventricles and to track fast atrial rates.

Search AV – This programmable feature searches for the patient's intrinsic AV conduction time and adjusts the Sensed AV (SAV) and the Paced AV (PAV) intervals to promote intrinsic activation of the ventricles and to track fast atrial rates.

Sensing Assurance – This feature automatically monitors the peak amplitude of sensed signals and adjusts atrial and ventricular sensitivities within defined limits to maintain adequate sensing margins. Sensing Assurance is enabled at the completion of Implant Detection.

Sensor-varied PVARP – This programmable timing interval allows the device to automatically adjust the PVARP, based on the sensor-indicated rate. This protects against pacemaker-mediated tachycardia (PMT) and provides a higher 2:1 block rate.

Single Chamber Hysteresis – This feature enables tracking of the patient's intrinsic rhythm below the programmed Lower Rate to prevent pacing during extended periods of inactivity, such as when a patient is sleeping.

Sinus Preference – This programmable feature is intended to improve cardiac hemodynamics by giving preference to sinus activation of the heart over sensor-driven pacing. The device searches for and then tracks an intrinsic sinus rate that is below the sensor-indicated rate in order to permit a slower intrinsic escape rate.

Sleep Function – This programmable feature suspends the programmed Lower Rate and replaces it with a Sleep Rate during a specified sleep period.

SVP (Smart Ventricular Pacing) – SVP promotes intrinsic conduction by reducing unnecessary right ventricular pacing. SVP operates when the programmed mode is either AAIR<=>DDDR or AAI<=>DDD.

Ventricular Output Management – This feature provides automatic monitoring of ventricular pacing thresholds. Ventricular Output Management may be programmed to automatically adjust the ventricular Amplitude and Pulse Width settings to maintain capture.

Ventricular Safety Pacing (VSP) – This feature prevents inappropriate inhibition of ventricular pacing caused by crosstalk or ventricular oversensing.

20 Declaration of conformity

For information regarding essential requirements for radio, telecommunications, and regulatory compliance information, refer to the separate insert.

21 Explanation of symbols

Refer to the package labels to see which symbols apply to this product.

Table 38. Explanation of symbols













Symbol	Explanation
	Conformité Européenne (European Conformity). This symbol means that the device fully complies with applicable European Union Acts.
	MR Conditional. The SureScan pacing system is safe for use in the MRI environment when used according to the instructions in the MRI technical manual. Note: Not all devices are MR Conditional.
 SureScan	Medtronic SureScan symbol
	Do not use if package is damaged
	Do not re-use
	Patient identification
	Date
	Health care center or doctor
	Patient information website
	Unique device identifier
	Medical device
	Double sterile barrier system
	Sterilized using ethylene oxide

Table 38. Explanation of symbols (continued)

















Symbol	Explanation
 <small>www.medtronic.com/manuals</small>	Consult instructions for use at this website
	Date of manufacture
	Manufacturer
	Manufactured in / Manufacturing site
	Importer
	Use by
	Reorder number
	Serial number
	Model number
	Accelerometer
	Transit temperature
	Adaptive
	Open here
	Open here
	Package contents
	Implantable device

Table 38. Explanation of symbols (continued)





















Symbol	Explanation
	Pacemaker (dual chamber)
	Header shape
	Product documentation
	Torque wrench
	IS-1 connector
	Amplitude / pulse width
	Amplitude and pulse width, RA
	Amplitude and pulse width, RV
	Sensitivity
	Sensitivity, RA
	Sensitivity, RV
	Polarity
	Pacing polarity
	Pacing polarity: RA, RV
	Sensing polarity
	Sensing polarity: RA, RV
	Refractory period

Table 38. Explanation of symbols (continued)

Symbol	Explanation
	PVARP (Post Ventricular Atrial Refractory Period)
	A-V interval (paced/sensed)
	Upper tracking rate/lower rate
	Magnet Rate

vitatron



Vitatron Holding B.V.

Endepolsdomein 5

6229 GW Maastricht

The Netherlands

+31 43 356 6551

© 2022 Vitatron Holding B.V.

M007512C001 B

2022-02-16



M007512C001