

MOUNTING AND OPERATING INSTRUCTIONS

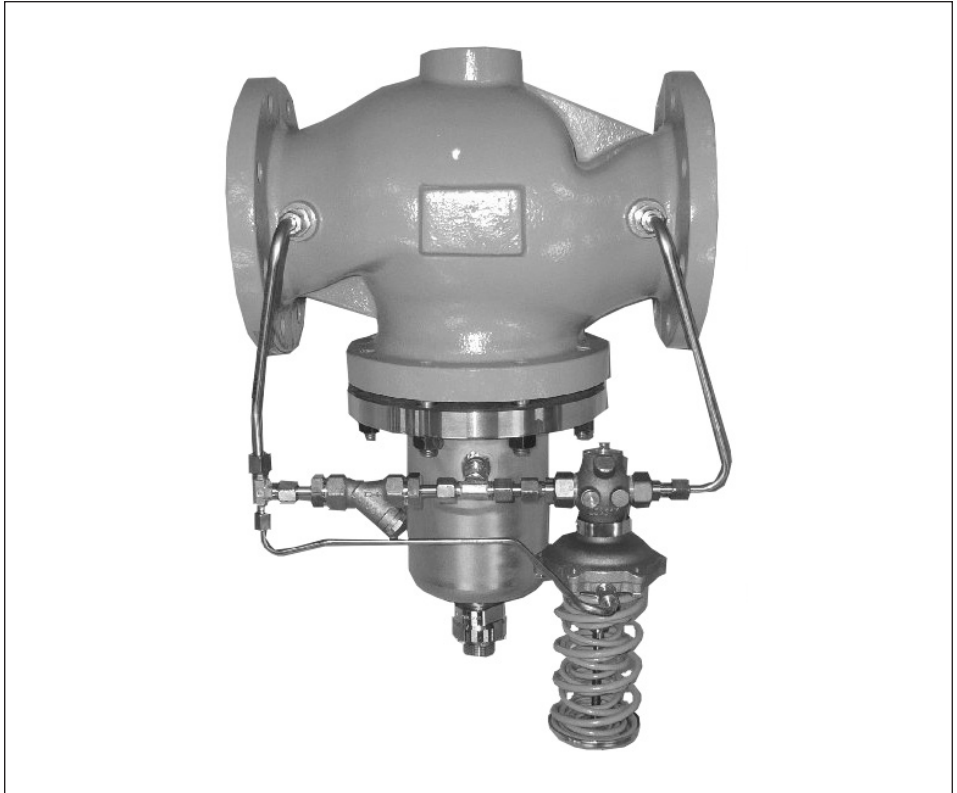

EB 2552-2 EN

Translation of original instructions



Type 2335 Excess Pressure Valve with pilot valve Self-operated Regulators

Edition October 2023



Note on these mounting and operating instructions

These mounting and operating instructions assist you in mounting and operating the device safely. The instructions are binding for handling SAMSON devices. The images shown in these instructions are for illustration purposes only. The actual product may vary.

- For the safe and proper use of these instructions, read them carefully and keep them for later reference.
- If you have any questions about these instructions, contact SAMSON's After-sales Service (aftersaleservice@samsongroup.com).



Documents relating to the device, such as the mounting and operating instructions, are available on our website at www.samsongroup.com > **Downloads > Documentation.**

Definition of signal words

DANGER

Hazardous situations which, if not avoided, will result in death or serious injury

WARNING

Hazardous situations which, if not avoided, could result in death or serious injury

NOTICE

Property damage message or malfunction

Note

Additional information

Tip

Recommended action

1	General safety instructions.....	4
2	Process medium and scope of application.....	5
2.1	Transportation and storage	5
3	Design and principle of operation	6
4	Installation	9
4.1	Notes on installation	9
4.2	Strainers	10
4.3	Shut-off valve.....	10
4.4	Pressure gauge	11
5	Operation	12
5.1	Start-up.....	12
5.2	Pressure test.....	12
5.3	Steam applications.....	13
5.4	Adjusting the set point	13
5.5	Decommissioning	13
6	Servicing.....	14
7	Nameplate.....	18
8	Technical data	19
9	Dimensions	21
10	After-sales service	23



1 General safety instructions

- The device must be mounted, started up or serviced by fully trained and qualified personnel only; the accepted industry codes and practices are to be observed. Make sure employees or third parties are not exposed to any danger.
- All safety instructions and warnings given in these mounting and operating instructions, particularly those concerning installation, start-up, and maintenance, must be strictly observed.
- According to these mounting and operating instructions, trained personnel refers to individuals who are able to judge the work they are assigned to and recognize possible dangers due to their specialized training, their knowledge and experience as well as their knowledge of the applicable standards.
- The devices comply with the requirements of the European Pressure Equipment Directive 2014/68/EU. Devices with a CE marking have an EU declaration of conformity, which includes information about the applied conformity assessment procedure. This EU declaration of conformity can be provided on request.
- To ensure appropriate use, only use the regulator in applications where the operating pressure and temperatures do not exceed the specifications used for sizing the regulator at the ordering stage.
- The manufacturer does not assume any responsibility for damage caused by external forces or any other external factors.
- Any hazards that could be caused in the valve by the process medium, operating pressure or by moving parts are to be prevented by taking appropriate precautions.
- Proper transport, storage, installation, operation and maintenance are assumed.

2 Process medium and scope of application

Pressure regulators for set points from 2 to 28 bar · Nominal sizes DN 65 to 400 · Pressure rating PN 16 to 40 · Suitable for liquids, gases and vapors up to 350 °C

The differential pressure across the regulator is used as auxiliary energy to operate the valve. To open the regulator, this pressure must be at least as high as the minimum differential pressure Δp_{\min} specified in Table 1.

The attached pilot valve (acting as an excess pressure valve) determines the function of the regulator.

⚠ WARNING

Risk of uncontrolled excess pressure in the plant.

Risk of bursting

If necessary, a suitable overpressure protection must be installed on site in the plant section.

2.1 Transportation and storage

The device must be carefully handled, transported and stored. Protect the regulator against adverse influences, such as dirt, moisture or temperature outside the ambient temperature range.

Do not remove the protective caps from the valve ports until immediately before installing the valve into the pipeline.

When regulators are too heavy to be lifted by hand, fasten the lifting equipment to a suitable place on the valve body.

⚠ WARNING

Do not attach lifting slings or lifting equipment to mounting parts, such as control line, pilot valve etc.

The valve can fall or mounting parts may be damaged.

Securely fasten slings or lifting equipment to the valve body and secure against slipping.

3 Design and principle of operation

See Fig. 1 and Fig. 2.

The medium flows through the globe valve (1) in the direction indicated by the arrow. The position of the plug determines the flow rate across the area released between plug (3) and seat (2). The travel position of the pilot valve (5) determines the pressure conditions across the valve.

The forces created by the upstream pressure p_1 acting on the plug surface and by the control pressure p_s acting on the balancing bellows (4) or balancing diaphragm (11) and the force of set point spring (3.1) are compared.

In the Type 2335 Excess Pressure Valve, the rising upstream pressure p_1 causes the main valve to open. Together with the pilot valve, the Venturi nozzle (8) (the fixed restriction (6) and needle valve (9) in the version for steam) create the control pressure p_s .

When the pilot valve is closed, the valve is fully balanced. The control pressure p_s between the pilot valve and Venturi nozzle act-

ing on the outside of the balancing bellows (4) or balancing diaphragm (11) and the upstream pressure p_1 balance each other out ($p_s = p_1$). The set point spring below the plug closes the valve.

When the pilot valve opens, the control pressure p_s falls, causing the differential pressure at the balancing bellows or balancing diaphragm to increase. The force acting on the plug surface opposes the force of the springs and the valve opens.

To ensure proper functioning, the minimum differential pressure Δp_{\min} must be available as specified depending on the field of application.

The regulator version for **steam** is only available with valves balanced by a bellows. This version has a compensation chamber (10) already fitted in the control line. The needle valve (9) is open and lead-sealed. A compensation chamber and needle valve are additionally required for the version for steam in nominal sizes DN 65 to 100.

Before start-up, fill the compensation chamber with water at the top filler opening.

Table 1: Minimum differential pressure Δp_{\min}

Nominal size		DN 65	DN 80	DN 100	DN 125	DN 150	DN 200	DN 250	DN 300	DN 400
Minimum differential pressure Δp_{\min}	Valve balanced by a bellows for steam applications	0.2 bar (640 cm ² actuator)			1.9 bar	2.0 bar	1.4 bar	1.4 bar	-	-
	Valve balanced by a bellows for air/water	0.4 bar (320 cm ² actuator)			1.0 bar	1.0 bar	0.7 bar	0.7 bar	-	-
	Valve balanced by a diaphragm	-			0.8 bar	0.8 bar	0.4 bar	0.4 bar	0.5 bar	0.3 bar

Type 2335 Excess Pressure Valve · Type 2422 Valve **balanced by a bellows** · DN 125 to 250¹⁾

Type 2422 as main valve balanced by a bellows

Version suitable for vapors

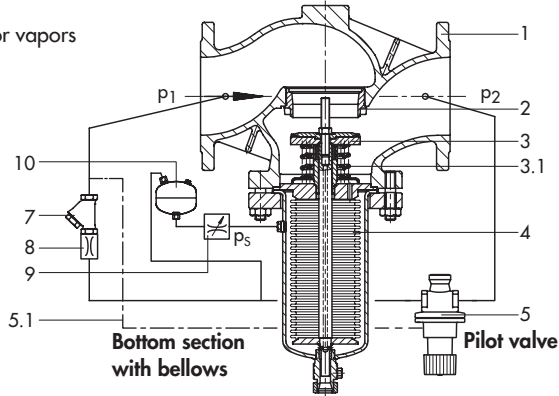

Bottom section with bellows

Pilot valve

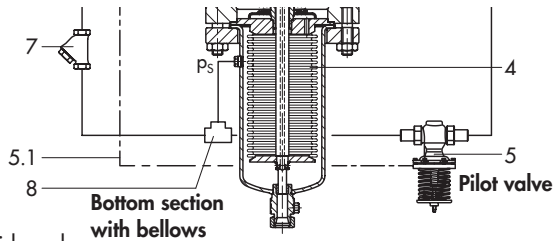

Bottom section with bellows

Pilot valve

Version suitable for liquids and gases

1	Globe valve (main valve)	7	Strainer
2	Seat	8	Fixed restriction (version for steam)
3	Plug with plug stem	9	Needle valve (version for steam)
3.1	Set point spring	10	Compensation chamber (only for steam or medium temperatures above 150 °C)
4	Balancing bellows	p _s	Control pressure
5	Pilot valve	p ₁	Upstream pressure
5.1	Control line for pilot valve	p ₂	Downstream pressure
6	Venturi nozzle (for gases and liquids)		

¹⁾ Version with compensation chamber and needle valve for steam in DN 65 to 100

Fig. 1: Functional diagram of valve balanced by a bellows

Design and principle of operation

Type 2335 Excess Pressure Valve · Type 2422 Valve, **balanced by a diaphragm** · DN 125 to 400

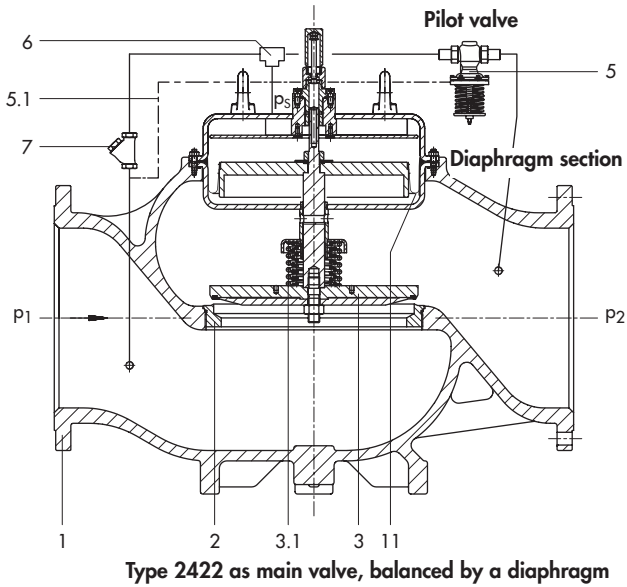

1	Valve body (main valve)	p _S	Control pressure
2	Seat	p ₁	Upstream pressure
3	Plug with plug stem	p ₂	Downstream pressure
3.1	Set point spring		
5	Pilot valve		
5.1	Control line for pilot valve		
6	Venturi nozzle		
7	Strainer		
11	Balancing diaphragm		

Fig. 2: Functional diagram of valve balanced by a diaphragm

4 Installation

See Fig. 3.

Select the installation location making sure that the regulator is installed at a distance of at least six times the nominal size (DN) away from pipe fittings or instruments that cause flow turbulence (e.g. pipe bends, manifolds, pressure measuring points or other valves). They can change the flow conditions which may lead to an instable control process especially in applications with gases, air or steam.

Contact SAMSON to obtain the TV-SK 17041 documentation which contains more details on installation requirements.

4.1 Notes on installation

Install the ready-assembled regulator in horizontal pipelines.

- Flush and clean the pipeline thoroughly before installing the regulator. Otherwise, impurities in the pipeline may impair the proper functioning of the valve, above all the tight shut-off.
- The direction of flow must match the direction indicated by the arrow on the body.
- Install the regulator free of stress. If necessary, support the pipeline near the connecting flanges. Do not attach supports directly to the valve or actuator.
- Install a strainer upstream of the regulator.

- Protect the regulator from icing up when controlling media that can freeze. If necessary, depressurize and drain the regulator and remove it from the pipeline while the plant is shut down.

i Note

The side on which the operating elements (hook-up of the pilot valve) are located varies depending on whether a valve balanced by a bellows or a diaphragm is used.

Mounting orientation

Observe the flow direction.

Valve balanced by a bellows

- Bellows including housing suspended downward.



Valve balanced by a diaphragm

- Balancing diaphragm (diaphragm section) pointing upward

Insulation · To insulate cold systems, we recommend first filling the plant and carefully rinsing it (see Chapter 5.1). The regulator must not be insulated until the set point is adjusted.

- Start up the plant and adjust the set point. Shut down the plant again and let it heat up until the condensation water has dried off.
- Afterwards, insulate the regulator and pipes conveying the process medium using insulation material with a water vapor barrier. If the pilot valve has a spring, it must be protected by a sleeve to allow it to move. The spring-

Installation

loaded actuator stem must not touch the insulation.

Thermal insulation

i Note

Do not insulate the pilot valve as well in applications with medium temperatures above 80 °C.

Pipeline routing

The inlet and outlet lengths vary depending on several variables and process conditions and are intended as recommendations. Contact SAMSON if the lengths are significantly shorter than the recommended lengths.

To ensure that the regulator functions properly, proceed as follows:

- Observe the inlet and outlet lengths (see Table 2). Contact SAMSON if the regulator conditions or state of the medium process deviate.
- Install the regulator free of stress and with the least amount of vibrations as possible.
- For media with a tendency to condensate, install the pipeline with a slight downward slope on both sides so that the condensate can drain properly. If the pipeline upstream and downstream of the regulator run vertically upwards, an automatic drainage is required.
- Install the regulator allowing sufficient space to remove the actuator and valve or to perform service work on them.

Pressure testing of the plant · The pressure must not exceed the maximum permissible pressure of the regulator and plant on testing the pressure of the plant when the regulator is already installed. An excessive test pressure can damage the balancing bellows or diaphragm. If necessary, remove the regulator from the pipeline or isolate the regulator in the pipeline and install a bypass.

4.2 Strainers

Install a strainer (e.g. SAMSON Type 1 / Type 2) upstream of the excess pressure valve.

- The direction of flow must correspond to the arrow on the body.
- Do not use the strainer to permanently filter the process medium.
- The filter element must be installed to hang downwards or sideways for applications with steam.

Tip

Remember to leave enough space to remove the filter element.

4.3 Shut-off valve

Install a hand-operated shut-off valve both upstream of the strainer and downstream of the regulator. This allows the plant to be shut down for cleaning and maintenance, and when the plant is not used for longer periods of time.

4.4 Pressure gauge

Install a pressure gauge both upstream and downstream of the regulator to monitor the pressures prevailing in the plant.

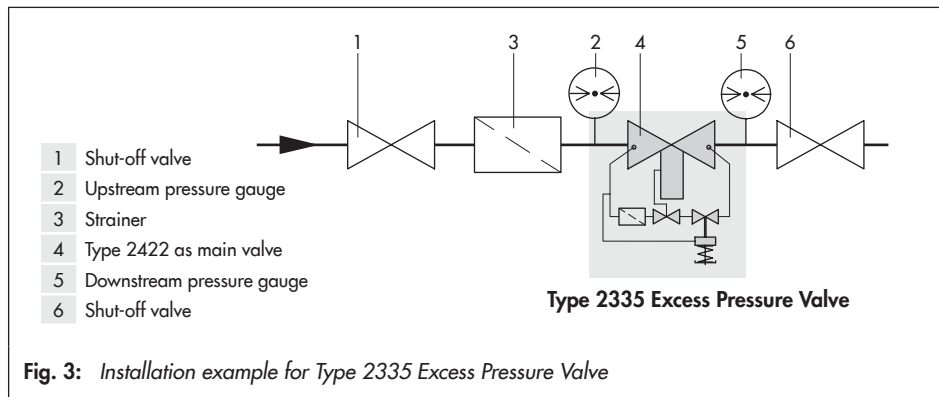

Table 2: Inlet and outlet lengths

a Inlet length
 b Outlet length

State of process medium	Valve conditions	Inlet length a	Outlet length b
Gas	$Ma \leq 0.3$	2	4
Vapors ¹⁾	$Ma \leq 0.3$	2	4
Liquid	Free of cavitation/ $w < 3 \text{ m/s}$	2	4
	Cavitation producing noise/ $w \leq 3 \text{ m/s}$	2	4

¹⁾ No wet steam

5 Operation

See Fig. 1 and Fig. 2.

5.1 Start-up

Do not start up the regulator until all parts have been mounted (e.g. valve and control line). Open control line with needle valve and check to ensure it is connected correctly.

Rinsing the plant · After filling the plant, first completely open the consumer and adjust the regulators to achieve the maximum flow rate. Rinse out the pipeline at full flow rate for several minutes. Check the installed strainer (e.g. by measuring the pressure drop). Clean the strainer, if necessary.

- Slowly fill the plant. Make sure that the pressure rises simultaneously upstream and downstream of the regulator to avoid damaging the balancing bellows/diaphragm.
- Open all the valves on the consumer side. Slowly open the shut-off valves starting on the flow pipe side in small steps waiting a few minutes in between.

5.2 Pressure test

i Note

The plant operator is responsible for performing the pressure test. SAMSON's After-sales Service can support you to plan and perform a pressure test for your plant.

! NOTICE

Risk of valve damage due to a sudden pressure increase and resulting high flow velocities.

– Slowly open the shut-off valves.

- The main valve is closed by the internal set point spring (3.1).

During the pressure test, make sure the following conditions are met:

- ➔ Do not allow the pressure to exceed the 1.5 times the pressure rating of the valve body.
- ➔ Unscrew the control lines from the main valve for the upstream pressure p1 and downstream pressure p2 and seal the openings at the main valve with screw plugs G 1/4 (DN 15 to 100) or G 3/8 (DN 125 to 250).
- ➔ Make sure that the pressure rises simultaneously upstream and downstream of the regulator to avoid damaging the balancing bellows or diaphragm.

5.3 Steam applications

Observe the following points for applications with steam:

- Before start-up, all pipes conveying the process medium must be completely drained and dry (to prevent steam hammering).
- Before start-up, fill the compensation chamber (10) with water (also at the pilot valve, if necessary).
- Slowly start up the plant and allow time for the pipes and valves to heat up.
- Air and condensate must be allowed to escape from the plant.

Install steam trap or air vent for steam-operated systems at a suitable location.

5.4 Adjusting the set point

Adjust the required set point while the plant (consumer) is open by turning the set point adjuster at the pilot valve (5).

When the adjusted upstream pressure (set point) is reached, the pilot valve opens, causing the main valve to open as well.

Turn clockwise (↻):

- To increase the pressure set point

Turn counterclockwise (↺):

- To reduce the pressure set point

The pressure gauge located on the upstream pressure side allows the adjusted set point to be monitored.

First set the maximum set point by turning the set point adjuster clockwise (↻).

Wait until the excess pressure valve starts to regulate before adjusting the set point by slowly turning the adjuster counterclockwise (↺).

! NOTICE

Incorrectly adjusted set point or set point cannot be adjusted.

Malfunction

Start by turning the set point adjuster by one turn at a time and wait until the downstream pressure reaches the set point. As soon as the excess pressure valve starts to work, you can adjust the set point by making larger changes. Wait several minutes until the pressure conditions have stabilized and check the set point. Correct the set point, if necessary.

After start-up and set point adjustment, avoid fast changes in pressure.

5.5 Decommissioning

Depressurize the plant. Close the shut-off valves starting from the flow pipe (high-pressure line).

6 Servicing

The excess pressure valve does not require much maintenance. Nevertheless, it is subject to natural wear, particularly at the seat, plug and operating diaphragm.

Depending on the operating conditions, check the regulator at regular intervals to avoid possible malfunctions.

⚠ WARNING

Be aware of the risks on performing work on pressurized or hot plant sections.

Hot process medium can escape uncontrolled on dismantling the regulator. Risk of scalding.

Allow the regulator to cool down before depressurizing and draining it and remove it from the pipeline.

Details on faults and how to remedy them can be found in Table 3 on page 15.

The listed examples of malfunctions are caused by mechanical faults in the main valve or pilot valve as well as incorrect regulator sizing.

In the simplest case, the functioning can be restored following the recommended action. To repair the pilot valve, read the operating instructions for the corresponding regulator (pilot valve). As in many cases, special tools are required, we advise you to contact SAMSON's after-sales service to find out how to proceed to repair the regulator or replace a component (see Chapter 10 on page 23).

Exceptional operating and installation conditions can lead to changed situations that may affect the control response and lead to malfunctions. In such cases, check the installation conditions, process medium, temperature and pressure conditions. A thorough analysis may often require the on-site assistance of SAMSON's After-sales Service.

The table is not intended to be exhaustive as there are diverse reasons for malfunctions.

Table 3: Troubleshooting

Malfunction	Possible reasons	Recommended action	Note
Malfunction only occurs when the consumer is closed or during low load:			
Upstream pressure does not reach the adjusted pressure set point	Pilot valve · Leak between seat and plug	Remove valve from the pipeline and clean seat and plug. Renew plug, if necessary. If this is not possible, return regulator for repair.	Install a shut-off valve instead of the pilot valve. If the main valve closes when the shut-off valve is closed, the pilot valve has caused the malfunction.
	Main valve · Leakage between seat and plug	Remove valve from the pipeline and clean seat and plug. Renew plug, if necessary. If this is not possible, return regulator for repair.	
	Balancing bellows/ diaphragm of the main valve defective.	Replace bellows/diaphragm.	Install a shut-off valve instead of the pilot valve. If the main valve does not open when the shut-off valve is opened, the main valve has caused the malfunction. Particularly in steam applications, steam hammering can damage the bellows. Therefore, make sure that no water or condensate is present in the pipeline before start-up.
Malfunction occurs when the consumer is open or at maximum load:			
Upstream pressure is much higher than the adjusted pressure set point	The pilot valve does not function. Balancing bellows/ diaphragm defective. Medium leaks from the actuator.	Replace the defective component.	Install a shut-off valve instead of the pilot valve and open it. If the main valve opens when the shut-off valve is open, the pilot valve has caused the malfunction.
	The pilot valve is blocked.	Clean the pilot valve. Apply grease to plug stem guides, if necessary. Replace defective parts.	
	Main valve seized up	Clean main valve.	Install a shut-off valve instead of the pilot valve and open it. If the main valve does not open when the shut-off valve is opened, the main valve has caused the malfunction.
	In steam applications: plant started up too quickly.	Fill condensation chambers with water. Slowly start up the plant.	

Servicing

Regulator's reaction is sluggish	Strainer in the line in which the pilot valve is installed is clogged up.	Clean the strainer.	
	Inside the pilot valve is clogged up, impairing the flow through the valve.	Clean the inside of the pilot valve.	
	Needle valve (steam) installed between fixed restriction and main valve is blocked.	Clean the needle valve. Check setting (open).	
	The fixed restriction is clogged up.	Clean fixed restriction.	
	Control line or Venturi nozzle blocked	Clean parts.	Improve steam conditioning, if necessary.

Troubleshooting (continued)

Malfunction	Possible reasons	Recommended action	Note
Control loop hunts	K_{VS}/C_V of pilot valve too large (after valve has been replaced).	Install pilot valve with suitable K_{VS}/C_V coefficient.	
	The flow conditions in the plant at the location where the regulator is installed are not suitable for the regulator.	Pipe reducers, instruments and diversions can change the flow conditions which may lead to an instable control process especially in applications with gases, air or steam. Refer to the SAMSON document TV-SK 17041 for minimum distances.	If this is the case, send a sketch of the plant to SAMSON for a thorough analysis.
	K_{VS}/C_V of main valve too large	Resize the valve. Replace main valve or reduced the flow rate (smaller K_{VS}/C_V coefficient).	
	Periodic excitation to vibrate originating from the plant	Contact SAMSON.	Possibly change the natural frequency, e.g. over the needle valve (9) when there is resonance in the plant.

Troubleshooting (continued)

Malfunction	Possible reasons	Recommended action	Note
The pressure does not reach the set point.	Strainer in the line in which the pilot valve is installed is clogged up.	Clean the strainer.	
	The required minimum differential pressure to operate the regulator is not available.	Raise upstream pressure or reduce downstream pressure.	
	Set point range of the pilot valve is too low.	Convert or replace pilot valve.	
	Main valve seized up	Clean main valve.	Install a shut-off valve instead of the pilot valve and open it. If the main valve does not open when the shut-off valve is opened, the main valve has caused the malfunction.
	The pilot valve is blocked.	Clean the pilot valve. Clean internal control line used to tap the upstream pressure.	
	Needle valve (steam) installed between fixed restriction and main valve is blocked or closed.	Clean the needle valve. Check setting (open).	
Main valve is sized to be too small (K_{VS}/C_V)	Resize the valve. Replace main valve.		

7 Nameplate

Nameplate of main valve

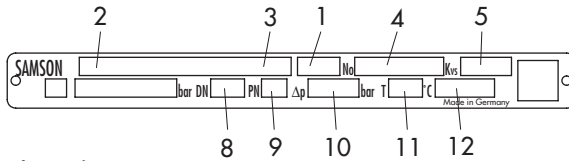

DIN version

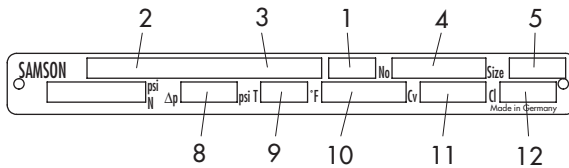

ANSI version

DIN valve

- 1 Valve type
- 2 Model number index
- 3 Material number
- 4 Order number or date
- 5 K_{vS} coefficient
- 8 Nominal size
- 9 Pressure rating
- 10 Perm. differential pressure in bar
- 11 Perm. temperature in °C
- 12 Body material

ANSI valve

- 5 Nominal size
- 8 Perm. differential pressure in psi
- 9 Perm. temperature in °F
- 10 Body material
- 11 C_v coefficient ($K_{vS} \times 1.17$)
- 12 Class (pressure rating)

Fig. 4: Nameplate of Type 2335 Excess Pressure Valve

8 Technical data

Table 4: Technical data · All pressures in bar (gauge)

Type 2422 Valve · Balanced by a bellows · Suitable for liquids, gases or vapors

Nominal size	DN 65	DN 80	DN 100	DN 125	DN 150	DN 200	DN 250
Pressure rating	PN 16 to 40						
Conformity							
Standard K_{VS} coefficients							
K_{VS} coefficient	50 ¹⁾	80 ¹⁾	125 ¹⁾	200	360	520	620
K_{VS} I (with flow divider ST 1)	38 ¹⁾	60 ¹⁾	95 ¹⁾	150	270	400	500
K_{VS} III (with flow divider ST 3)	25 ¹⁾	40 ¹⁾	60 ¹⁾	100	180	260	310
x_{FZ} value	0.4	0.35				0.3	
Min. differential pressure Δp_{min}	For vapors		0.2 bar (640 cm ² actuator) ¹⁾		1.9 bar/ 3.0 bar ²⁾	2.0 bar/ 3.0 bar ²⁾	1.4 bar/3.0 bar ²⁾
	For gases and liquids		0.4 bar (320 cm ² actuator) ¹⁾		1.0 bar/ 3.0 bar ²⁾		0.7 bar/3.0 bar ²⁾
Max. permissible differential pressure Δp_{max}	20 bar		16 bar	16 bar/ 35 bar ²⁾	12 bar/ 35 bar ²⁾	10 bar/25 bar ²⁾	
Reduced K_{VS} coefficient							
K_{VS} coefficient	32 ¹⁾		80 ¹⁾		125 ¹⁾	360	
K_{VS} I (with flow divider ST 1)	-			60 ¹⁾	95 ¹⁾	270	
K_{VS} III (with flow divider ST 3)	-			40 ¹⁾	60 ¹⁾	180	
x_{FZ} value	0.4	0.35				0.3	
Min. differential pressure Δp_{min}	For vapors		0.4 bar (640 cm ² actuator) ¹⁾		-		1.9 bar 2.0 bar
	For gases and liquids		0.8 bar (320 cm ² actuator) ¹⁾		0.2 bar ¹⁾		1.0 bar
Max. permissible differential pressure Δp_{max}	20 bar				16 bar	12 bar	
Leakage class according to IEC 60534-4	I ≤ 0.05 % of K_{VS} coefficient (metal seal) IV ≤ 0.01 % of K_{VS} coefficient (soft seal)						
Max. permissible temperature (depending on the pilot valve)	Type 2406: 60 °C ⁴⁾ · Type 44-6 B: 150 °C/200 °C ³⁾ Type 44-7: 150 °C · Type 41-73: 150 °C/350 °C ³⁾						
Set point ranges in bar, continuously adjustable at the pilot valve	Type 2406: 2 to 5, 4,5 to 10 · Type 44-6 B: 2 to 6, 4 to 10, 8 to 20 Type 44-7: 2 to 4.4, 2,4 to 6.6, 6 to 11 Type 41-73: 2 to 5, 4.5 to 10, 8 to 16, 10 to 22, 20 to 28						

¹⁾ Version with Type 2420 Diaphragm Actuator, 640 cm²

³⁾ Version for steam

²⁾ Reinforced version with bellows

⁴⁾ Special version up to 150 °C

Technical data

Type 2422 Valve · Balanced by a diaphragm · Suitable for liquids and gases

Nominal size	DN 125	DN 150	DN 200	DN 250	DN 300	DN 400 ⁴⁾
Pressure rating	PN 16 to 40					
Conformity	CE · EN					
K _{V5} coefficient	250	380	650 ¹⁾	800 ¹⁾	1250	2000
x _{FZ} value	0.35		0.3 ¹⁾		0.2	
Minimum differential pressure Δp _{min}	0.8 bar		0.4 bar ¹⁾		0.5 bar	0.3 bar
Max. permissible differential pressure Δp _{max}	12 bar		10 bar ¹⁾			6 bar
Leakage class according to IEC 60534-4	≤0.01 % of K _{V5} coefficient					
Max. permissible temperature ^{2) 4)} Depends on the pilot valve	Type 2406: 60 °C ³⁾ Type 44-6 B: 150 °C Type 44-7: 150 °C Type 41-73: 150 °C					
Set point ranges in bar, continuously adjustable at the pilot valve	Type 2406: 2 to 5, 4.5 to 10 Type 44-6 B: 2 to 6, 4 to 10, 8 to 20 Type 44-7: 2 to 4.4, 2.4 to 6.6, 6 to 11 Type 41-73: 2 to 5, 4.5 to 10, 8 to 16, 10 to 22, 20 to 28					

¹⁾ Version with reduced K_{V5} coefficient possible. Same technical data as DN 150.

²⁾ Steam pressure regulator as special version on request

³⁾ Special version up to 150 °C

⁴⁾ Max. 80 °C with DN 400

9 Dimensions

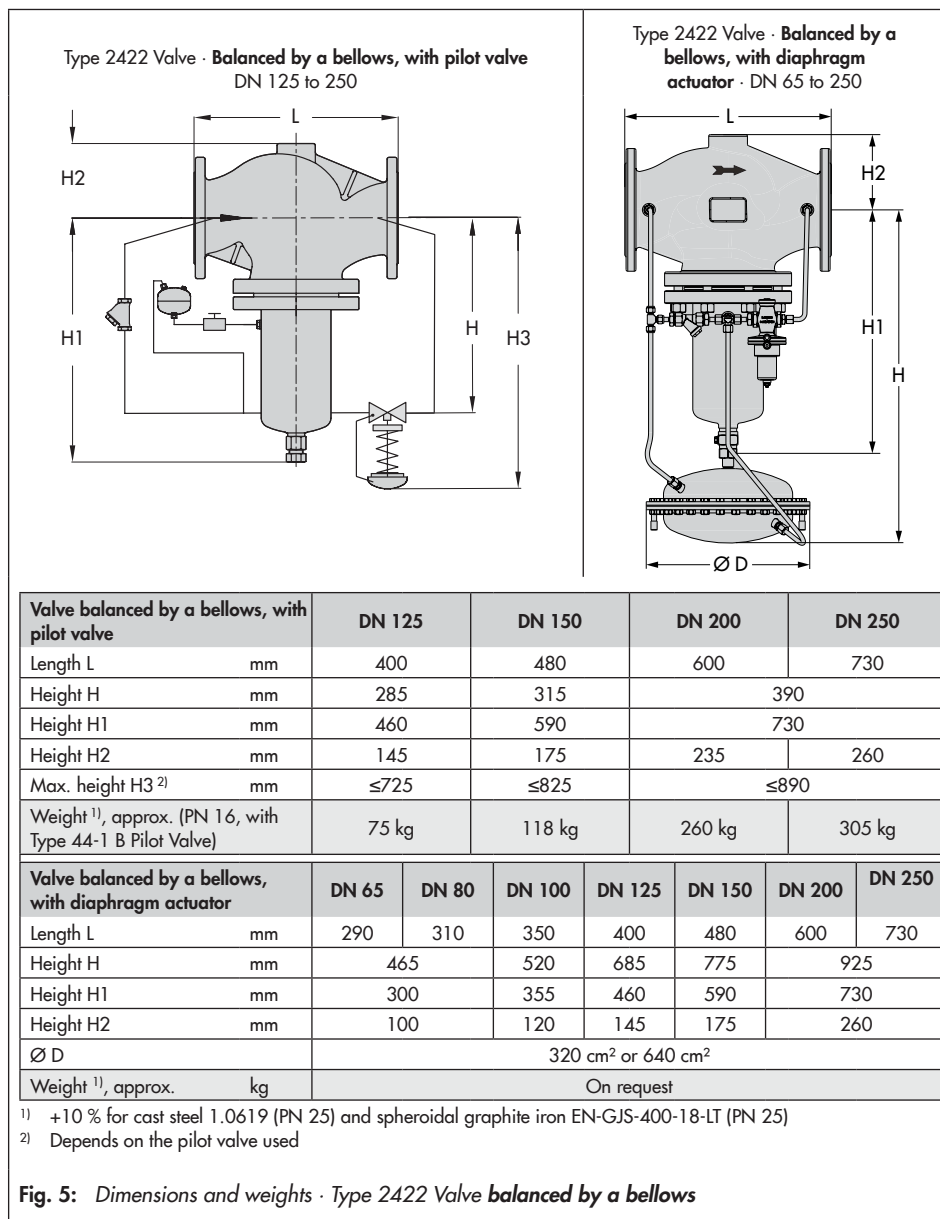

Dimensions

Type 2422 Valve · **Balanced by a diaphragm, with pilot valve** · DN 125 to 400

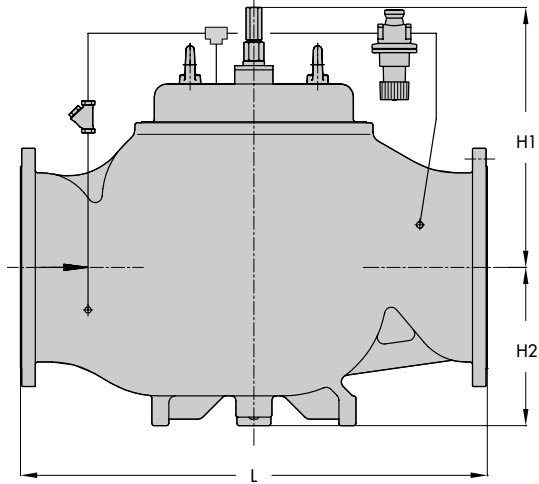

Valve balanced by a diaphragm, with pilot valve		DN 125	DN 150	DN 200	DN 250	DN 300	DN 400
Length L	mm	400	480	600	730	850	1100
Height H1	mm	285	310	380		510	610
Height H2	mm	145	175	260		290	390
Weight ¹⁾ , approx. (PN 16, with Type 44-1 B Pilot Valve)		50 kg	70 kg	210 kg	305 kg	315 kg	625 kg

¹⁾ +10 % for cast steel 1.0619 (PN 25) and spheroidal graphite iron EN-GJS-400-18-LT (PN 25)

Fig. 6: Dimensions and weights · Type 2422 Valve **balanced by a diaphragm**

10 After-sales service

If malfunctions or defects occur, contact the SAMSON's After-sales Service for support.

The addresses of SAMSON AG, its subsidiaries, representatives and service facilities worldwide can be found on the SAMSON website (► www.samsongroup.com), in all SAMSON product catalogs or on the back of these Mounting and Operating Instructions.

Please send your inquiries to: service@samsongroup.com

To assist diagnosis, specify the following details (see Chapter 6 on page 14):

- Valve type and nominal size
- Order and model number
- Order number or date
- Upstream and downstream pressure
- Temperature and process medium
- Min. and max. flow rate in m³/h
- Is a strainer installed?
- Installation drawing showing the exact location of the regulator and all the additionally installed components (shut-off valves, pressure gauge etc.)
- Photo of the installed regulator, if possible

EB 2552-2 EN



SAMSON AKTIENGESELLSCHAFT
Weismüllerstraße 3 · 60314 Frankfurt am Main, Germany
Phone: +49 69 4009-0 · Fax: +49 69 4009-1507
samson@samsongroup.com · www.samsongroup.com