











Valves | Combi valves



<p>Page A 2</p>	<p>E3 Flange gate valve Standard DN 50 — 600 Reductions E-valve DN 20 — 40</p>	<p>Page A 2/3 Page A 2/7 Page J 3/1</p>	
<p>Page A 3</p>	<p>E3 Valve spigot ends E3 Valve spigot ends With flange</p>	<p>Page A 3/1 Page A 3/3</p>	
<p>Page A 4</p>	<p>E3 Valve for PE and PVC pipes Valve system 2000 socket-socket Valve system 2000 socket-flange Valve system BAIO socket-socket Valve for PE fusion PE-PE Valve for PE fusion PE-flange</p>	<p>Page F 2/3 Page F 2/5 Page G 3/1 Page A 4/1 Page A 4/3</p>	
<p>Page A 5</p>	<p>E3 Valve for ductile iron pipes Valve system BAIO socket-socket Valve system BAIO socket-spigot Valve system VRS socket-spigot</p>	<p>Page G 3/1 Page G 4/1 Page A 5/1</p>	
<p>Page A 6</p>	<p>E3 Combi-T Combi-T with flange Combi-T System 2000 socket Combi-T System BAIO socket</p>	<p>Page A 6/1 Page F 3/1 Page G 5/1</p>	
<p>Page A 7</p>	<p>E3 Combi-III Combi-III with flange Combi-III system BAIO</p>	<p>Page A 7/1 Page G 5/2</p>	
<p>Page A 8</p>	<p>E3 Combi-IV Combi-IV with flange</p>	<p>Page A 8/1</p>	
<p>Page A 9</p>	<p>E3 Hawle-Combiflex With flange DN 150 With flange DN 250, DN 300</p>	<p>Page A 9/1 Page A 9/5</p>	
<p>Page A 10</p>	<p>Hawle-E1+ valve</p>	<p>Page A 10/1</p>	
<p>Page A 11</p>	<p>Hawle-E2 valve With flange DN 450 — 600</p>	<p>Page A 11/1</p>	

E3 Gate valve

Overview

- Medium: Water, seawater, gas*
- In accordance to EN 1074-1 and -2

Advantages Hawle-E3 Gate valve

- O-ring carrier with double bayonet (up to DN 200) or heavy-duty O-ring carrier with centering flange (> DN 200) in inside and outside fully coated bonnet
- POM sliding disks (up to DN 200) and an additional axial ball bearing (> DN 200) ensure low torque actuation
- Duplex stainless steel spindle
- Extended edge protection
- Wedge and wedge nut fully coated with vulcanized elastomer
- The wedge is connected to the wedge nut with a flexible link and embedded in elastomer. This snug fit dampens vibration during opening and closing of the wedge
- Stainless steel allen screws in bonnet
- 100% corrosion protection
- E3 bonnets are entirely compatible with all E2 bodies and accessories
- Full straight bore – suitable for pigging the pipeline
- Spindle O-rings replaceable under operating pressure up to DN 400
- All components made in the EU, including ductile iron parts

Hawle-quality Guarantee



E3 Gate valve | Combi valves

Overview

Design features

- Resilient seated gate valve according to EN 1171, EN 1074-1 and EN 1074-2 with smooth, straight-through bore
- Double bayonet O-ring carrier is connecting the spindle to the bonnet, allowing a fully encased, uniform epoxy powder coated bonnet for further improved corrosion protection
- Wedge guide made of wear resistant POM material in load optimized design minimizes attrition and ensures lowest torque actuation
- Wedge is flexible and fully linked in vulcanized elastomer to the wedge nut. This snug fit dampens vibration during opening and closing of the wedge
- Wedge nut has a long thread length allowing significantly higher torques than the standard before breaking
- O-rings, lip-seals mounted in the bonnet are replaceable under operating pressure
- Extended edge protection to avoid damages during transport, storage and assembly
- Sliding disks and ball bearing assure low friction performance of the spindle
- 100% suitable for buried installations

Material | Technical features

- 1,2 Body (1), bonnet (2), centering flange (16) made of ductile iron,
- 16 epoxy powder coated inside and out
- 3 Wedge made of ductile iron (DN 50 made of dezincification-resistant brass) with vulcanized elastomer all-over
- 4 Wedge guide made of wear-resistant plastic
- 5 Wedge nut made of dezincification-resistant brass
- 6 Duplex stainless steel spindle with rolled thread and flat-rolled anti-friction surface
- 7 O-ring carrier made of brass, DN 50 – 200 with double bayonet
- 8 O-rings made of elastomer
- 9 Wiper ring made of PE
- 10 Bonnet gasket made of elastomer
- 11 Allen screws made of stainless steel, encased into the body with interlacing gasket and sealing compounds, ensuring full corrosion protection
- 12 Extended edge protection made of PE
- 13 Spindle bearing made of dezincification resistant brass
- 14 Sliding disks made of POM
- 15 Safety screw made of stainless steel
- 17 Centering flange gasket made of elastomer
- 18 Axial ball bearing permanently lubricated
- 19 Centering ring made of POM
- 20 Lip seals made of elastomer
- 21 Wiper ring made of elastomer

DN 50 – 200

Spindle bearing with sliding disks

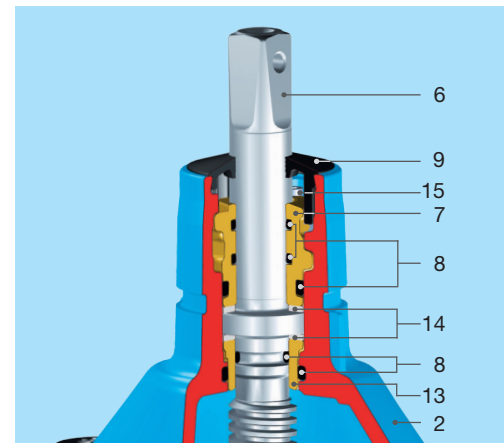

DN 250 – 400 Spindle bearing with ball bearing and additional sliding disks

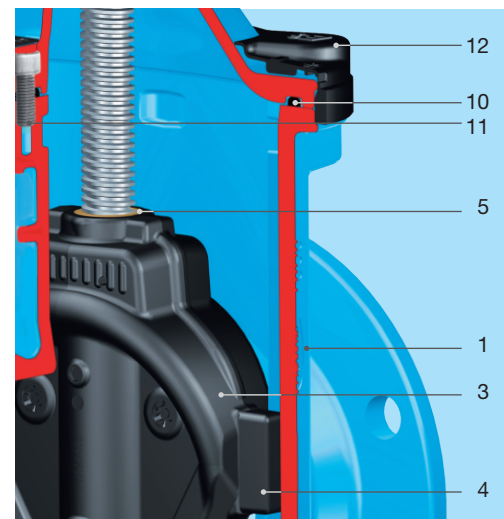
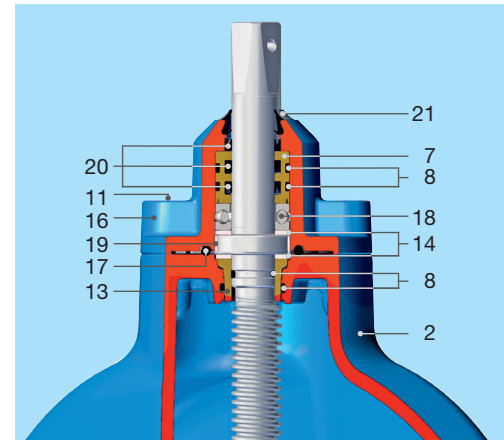

DN 500 – 600 in preparation -
currently available - see page A 11/3

Valves | Combi valves

Accessories

Handwheels	Page M 4/1
Extension spindles	Page M 2/1
Surface boxes	Page M 3/1
Base plate	Page M 3/7
Adapter and coupling socket	Page M 4/3
Operating cap	Page M 4/1
Spindle extension	Page M 4/1
Actuator	Page M 4/3
Position indicator	Page M 4/2
Bolts	Page M 4/4
HAWAK-pillar	Page M 5/1
Flat gaskets	Page M 7/1
Blanking cap	Page M 4/1
Flanges	Page C 4/1
Dismantling pieces	Page D 6/1

Tools

Operating key	Page Q 4/2
---------------	------------

Technical information

Tightening torques for flange assembly	Page R 3/1
Pressure loss diagram	Page R 4/1
Spindle rotations per stroke	Page R 1/2

Application examples

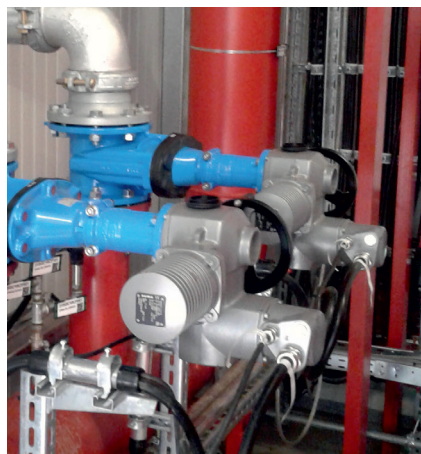

E3 Gate valve

With flange DN 50 – 200, PN 10 | PN 16 | PN 25



Design features

- Resilient seated gate valve with smooth straight-through bore
- Flanges sized in accordance with EN 1092-2, drilled according to
EN 1092-2 | PN 10 standard (4000E3, 4700E3);
EN 1092-2 | PN 16 from DN 200 (4000E3, 4700E3)
EN 1092-2 | PN 25 (4010E3, 4710E3)
Please specify on order - other standards on request
- Suitable for cleaning with a cleaning pig
- One extension spindle for several dimensions
- Suitable for operation by automatic actuators
- Easy retrofitting of position indicator and automatic actuators on the standard bonnet
- Duplex stainless steel spindle

Standard version: without handwheel and extension spindle

Design versions:

for actuator:	No. 4000ELE3
with actuator:	No. 4000EME3
with position indicator:	No. 4000STE3
for seawater:	No. 4002E3, No. 4702E3

Special versions: on request

No. 4000E3
No. 4700E3
No. 4010E3
No. 4710E3*
No. 4060E3*



Suitable accessories

Suitable accessories: see page A 2/2

Handwheel:		No. 7800
Extension spindles:	rigid	No. 9000E2/E3
	telescopic	No. 9500E2/E3
Surface boxes:	rigid	No. 1750
	telescopic	No. 2050
		No. 2051K
Valve actuator:		No. 9920
Adapter for actuator (E2/E3 adapter):		No. 8630E2/E3
Base plate:	No. 3481, No. 3482	
Operating cap:	No. 2156, No. 2157, No. 2158	
Extension spindle:	No. 7820, No. 7825	
Position indicator:	No. 2170E2/E3	
Bolts:	No. 8810, No. 8830, No. 8840	
HAWAK-pillar:	No. 9894, No. 9895	
Flat gasket:	No. 3390, No. 3470	

Order no.	Version	MOP (PN)	Dimensions/DN							
			50	65	80	100	125	150	200	
4000E3	short EN 558 GR 14	16								
4700E3	long EN 558 GR 15	16								
4010E3	short EN 558 GR 14	25								
4710E3*	long EN 558 GR 15	25								
4060E3*	to BS 5163 to AS 2638	16			*	*		*	*	

*in preparation

Application examples



E3 Gate valve

With flange DN 50 – 200, PN 10 | PN 16 | PN 25

No. 4000E3

No. 4700E3

No. 4010E3

No. 4710E3*

No. 4060E3*

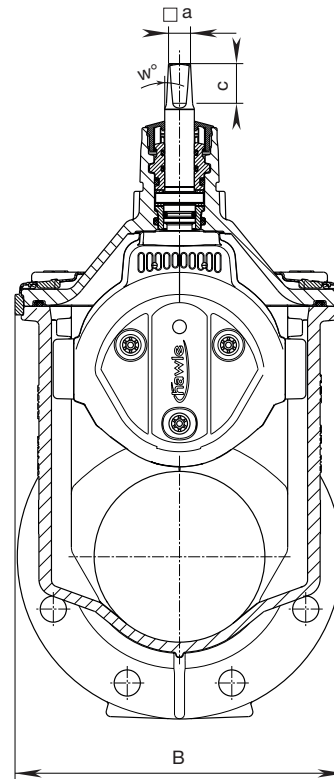
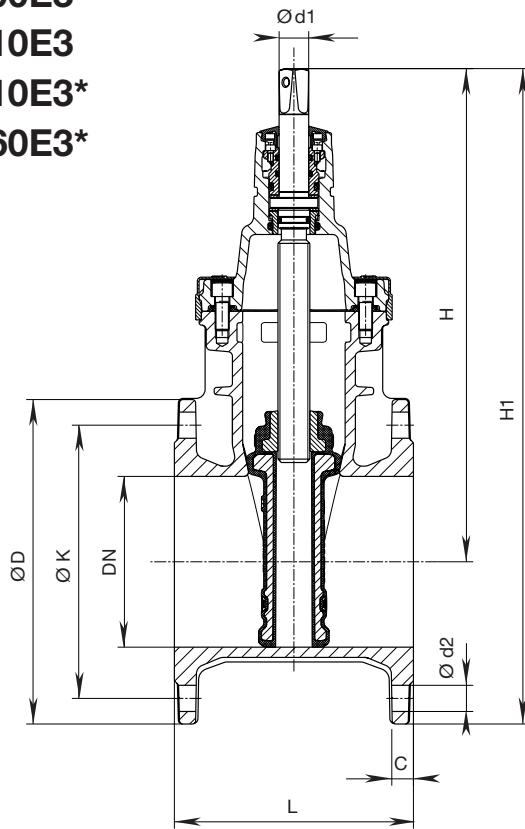

DN	MOP (PN)	Flange			Bolts			Spindle			Valve					Weight																							
		ØD	C	ØK	Qty.	Thread	Ød2	□ a	c	w°	Ød1	H	H1	L short	L long	BS 5163 AS 2638	B	short	long	BS 5163 AS 2638																			
50	10	165	19	125	4	M 16	19	14,8	33	3°	20,5	234	316,5	150	250		143	10,0	11,5	10,5																			
	16																																						
	25																																						
65	10	185	19	145	4	M 16	19	17,3	35	3°	24	305	397,5	170	270		180	15,5	17,5																				
	16																																						
	25*																	8																					
80	10	200	19	160	8	M 16	19	17,3	38	3°	24	312,5	412,5	180	280	203	180	16,5	20,0	18,0																			
	16																																						
	25*																																						
100	10	220	19	180	8	M 16	19	19,3	39	3°	24	343	453	190	300	229	212	20,5	25,5	23,5																			
	16																																						
	25*																	235	190		M 20	23																	
125	10	250	19	210	8	M 16	19	19,3	39	3°	26	421	546	200	325		289	33,0	37,5																				
	16																																						
	25*																	270	220		M 24	28																	
150	10	285	19	240	8	M 20	23	19,3	39	3°	26	433	576	210	350	267	289	37,0	43,5	41,0																			
	16																																						
	25*																	300	250		M 24	28																	
200	10	340	20	295	8	M 20	23	24,3	49	3°	30	541	711	230	400	292	356	60,5	71,5	65,0																			
	16																																						
	25*																	360	310	12	M 24	28																	

*in preparation

E3 Gate valve

With flange DN 250 – 400, PN 10 | PN 16 | PN 25



Design features

- Resilient seated gate valve with smooth straight-through bore
- Flanges sized in accordance with EN 1092-2, drilled according to
EN 1092-2 | PN 10 standard (4000E3, 4700E3);
EN 1092-2 | PN 16 from DN 200 (4000E3, 4700E3);
EN 1092-2 | PN 25 (4710E3)
Please specify on order - other standards on request
- Suitable for cleaning with a cleaning pig
- Suitable for operation by automatic actuators
- O-rings lip-seals replaceable under operating pressure up to DN 400
- Ball bearings in the spindle seating minimizes closing forces
- Easy to actuate without bypass and without power boost - even for 16 bar differential pressure
- For mounting a position indicator it is necessary to remove the centering flange and attach the adapter for position indicator

No. 4000E3
No. 4700E3
No. 4710E3
No. 4060E3*



Standard version: without handwheel and extension spindle

Design versions:

for actuator:	No. 4000ELE3
with actuator:	No. 4000EME3
with position indicator:	No. 4000STE3
for seawater:	No. 4002E3, No. 4702E3

Special versions: on request
- Bevel gearing

Suitable accessories

Suitable accessories: see page A 2/2

Handwheel:	No. 7800
Extension spindles:	rigid No. 9000E2/E3 telescopic No. 9500E2/E3
Surface boxes:	rigid No. 1750 telescopic No. 2050
Valve actuator:	No. 2051K No. 9920
Adapter for actuator (E3 adapter):	No. 8630E3
Base plate:	No. 3481, No. 3482
Operating cap:	No. 2156, No. 2157, No. 2158
Extension spindle:	No. 7820, No. 7825
Bolts:	No. 8810, No. 8830, No. 8840
HAWAK-pillar:	No. 9894, No. 9895
Flat gasket:	No. 3390, No. 3470

Order no.	Version	MOP (PN)	Dimensions/DN					
			250	300	350	400	500*	600*
4000E3	short EN 558 GR 14	16					*	*
4700E3	long EN 558 GR 15	16					*	*
4710E3	long EN 558 GR 15	25						
4060E3	to BS 5163 to AS 2638	16						

*in preparation - currently available in E2 version, see page A 11/3

E3 Gate valve

With flange DN 250 — 400, PN 10 | PN 16 | PN 25

No. 4000E3

No. 4700E3

No. 4710E3

No. 4060E3*

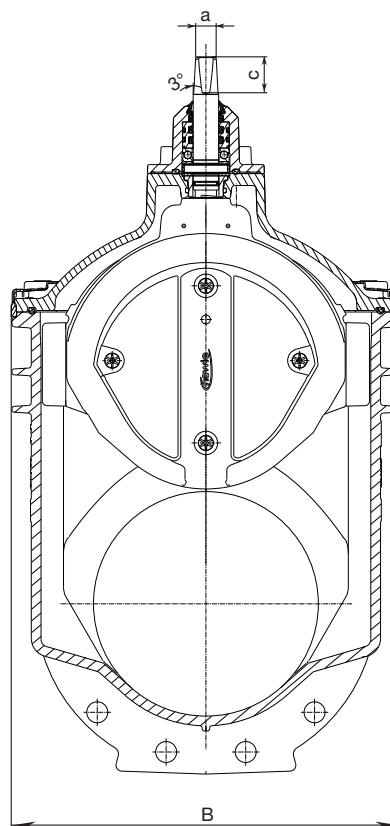
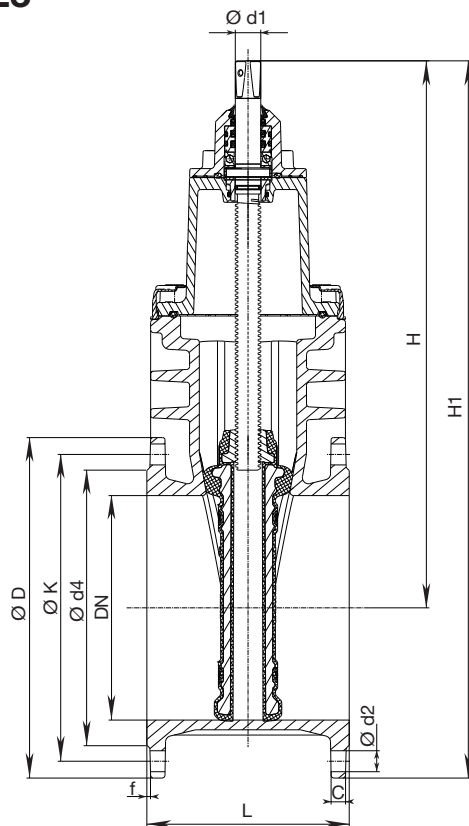

DN	MOP (PN)	Flange					Bolts			Spindle			Valve				Weight													
		Ø D	C	Ø K	Ø d4	f	Qty.	Thread	Ø d2	a	c	Ø d1	H	H1	L short	L long	BS 5163 AS 2638	B	short	long	BS 5163 AS 2638									
250	10	400	22	350	319	3	12	M 20	23	27,3	48	34	649	849	250	450	330	436	98,5	114,5	109,0									
	16			355																										
	25	425	24,5	370	330				M 24					28									862					102,0	110,0	
300	10	455	24,5	400	367	4	12	M 20	23	27,3	48	34	731	958	270	500	356	520	151,0	169,5	167,0									
	16			410					M 24					28																
	25	485	27,5	430	389		5	16	M 27					31									973					150,0	169,0	
350	10	520	26,5	460	427	4	16	M 20	23	27,3	48	34	816	1076	290			604	205,5											
	16			470					M 24					28																
400	10	580	28	515	477	4	16	M 24	28	32,3	55	44	925	1215	310	600		687	266,0	310,0										
	16			525					M 27					31																
500*	10*																													
	16*																													
600*	10*																													
	16*																													

*in preparation - currently available in E2 version, see page A 11/3

E3 Reducing valve

With flange DN 65 – 300, PN 10 | PN 16



Design features

- Resilient seated gate valve with unequal flange sizes
- Flanges sized in accordance with EN 1092-2, drilled according to EN 1092-2 | PN 10 standard; EN 1092-2 | PN 16 DN 200 please specify on order - other standards on request
- This E3 reduction valve is a gate valve and a reducing connector in one piece; this feature provides for a multitude of application possibilities for the most efficient material and space requirements
- One extension spindle for several dimensions
- Suitable for operation by automatic actuators
- Easy retrofitting of position indicator and automatic actuators on the standard bonnet
- Duplex stainless steel spindle

No. 4150E3



Standard version: without handwheel and extension spindle

Design versions: for actuator: No. 4150ELE3
with position indicator: No. 4150STE3

Special versions: on request

Suitable accessories

Suitable accessories: see page A 2/2

Handwheel:		No. 7800
Extension spindles:	rigid	No. 9000E2/E3
	telescopic	No. 9500E2/E3
Surface boxes:	rigid	No. 1750
	telescopic	No. 2050 No. 2051K
Valve actuator:		No. 9920
Adapter for actuator (E2/E3 adapter):		No. 8630E2/E3
Base plate:		No. 3481, No. 3482
Operating cap:		No. 2156, No. 2157, No. 2158
Extension spindle:		No. 7820, No. 7825
Position indicator:		No. 2170E2/E3
Bolts:		No. 8810, No. 8830, No. 8840
HAWAK-pillar:		No. 9894, No. 9895
Flat gasket:		No. 3390, No. 3470

Order no.	MOP (PN)	Dimensions/DN*													
		100 65	100 80	125 80	125 100	150 80	150 100	150 125	200 100	200 150	250 150	250 200	300 150	300 200	300 250
4150E3	16														

* The valve is sized in accordance with the smaller flange

E3 Reducing valve

With flange DN 65 – 300, PN 10 | PN 16

No. 4150E3

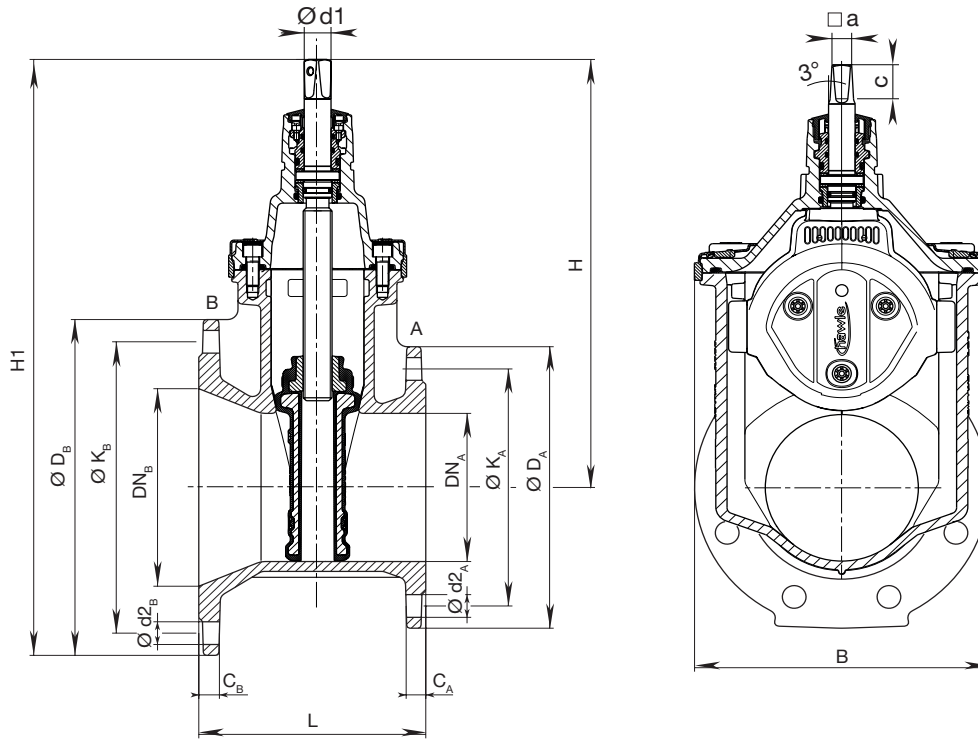

DN	MOP (PN)	Flange A					Flange B					Spindle			Valve				Weight
		ØD _A	C _A	ØK _A	Ød _{2A}	n _A *	ØD _B	C _B	ØK _B	Ød _{2B}	n _B *	a	c	Ød1	H	H1	L	B	
100 – 65	10 16	185	19	145	19	4	220	19,0	180	19	8	17,3	35	25	305	415	180	180	18,0
100 – 80	10 16	200	19	160	19	8	220	19,0	180	19	8	17,3	35	25	313	423	190	180	19,5
125 – 80	10 16	200	19	160	19	8	250	19,0	210	19	8	17,3	35	25	313	438	200	180	21,5
125 – 100	10 16	220	19	180	19	8	250	19,0	210	19	8	19,3	38	25	343	468	200	213	24,0
150 – 80	10 16	200	19	160	19	8	285	19,0	240	23	8	17,3	35	25	313	456	200	180	24,0
150 – 100	10 16	220	19	180	19	8	285	19,0	240	23	8	19,3	38	25	343	486	210	213	26,5
150 – 125	10 16	250	19	210	19	8	285	19,0	240	23	8	19,3	38	28	421	564	210	285	36,0
200 – 100	10 16	220	19	180	19	8	340	20,0	295	23	8 12	19,3	38	25	343	513	210	213	29,0
200 – 150	10 16	285	19	240	23	8	340	20,0	295	23	8 12	19,3	38	28	433	603	220	285	42,5
250 – 150	10 16	285	19	240	23	8	400	22,0	350 355	23 28	12	19,3	38	28	433	633	230	285	49,0
300 – 150	10 16	285	19	240	23	8	455	24,5	400 410	23 28	12	19,3	38	28	433	661	240	285	68,0
250 – 200	10 16	340	20	295	23	8 12	400	22,0	350 355	23 28	12	24,3	48	32	541	741	240	357	69,0
300 – 200	10 16	340	20	295	23	8 12	455	24,5	400 410	23 28	12	24,3	48	32	541	769	250	357	74,0
300 – 250	10 16	400	22	350 355	23 28	12	455	24,5	400 410	23 28	12	27,3	48	34	649	877	260	432	105,0

The valve is sized in accordance with the smaller flange n_A*, n_B* = bolts per flange

E3 Valve spigot ends

PN 16



Design features

- Resilient seated gate valve with smooth straight-through bore
- The Hawle E3 spigot valve with smooth spigot ends is a universal type, suitable for both flange as well as for socket connections
- Easy replacement of old flange valve to insertion of HAWLE-flange, as insertion of flat gaskets is not required; special lengths can even be produced through shortening of the spigot ends
- The outside diameters of the spigot ends correspond to that of the cast iron pipes (other size on request)
- Suitable for cleaning with a cleaning pig
- One extension spindle for several dimensions
- Suitable for operation by automatic actuators
- Easy retrofitting of position indicator and automatic actuators on the standard bonnet

No. 4100E3

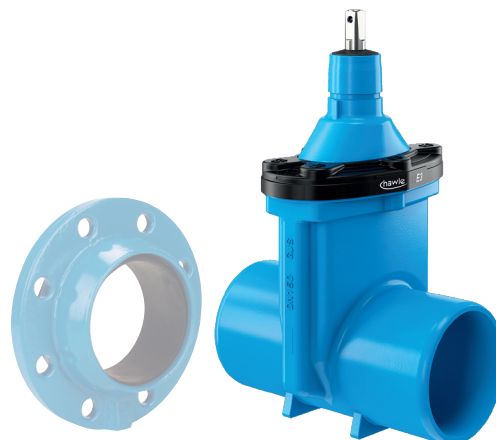

Standard version: without flanges, handwheel and extension spindle

No. 4140E3



Suitable accessories

Suitable accessories: see page A 2/2

Flange:		No. 7102 No. 0102
Handwheel:		No. 7800
Extension spindles:	rigid	No. 9000E2/E3
	telescopic	No. 9500E2/E3
Surface boxes:	rigid	No. 1750
	telescopic	No. 2050 No. 2051K No. 9920
Valve actuator:		No. 9920
Adapter for actuator (E2/E3 adapter):		No. 8630E2/E3
Base plate:	No. 3481, No. 3482	
Operating cap:	No. 2156, No. 2157, No. 2158	
Extension spindle:	No. 7820, No. 7825	
Position indicator:	No. 2170E2/E3	
Bolts:	No. 8810, No. 8830, No. 8840	
HAWAK-pillar:	No. 9894, No. 9895	

Order no.	Version	Face-to-face length	MOP (PN)	Dimensions/DN											
				50	65	80	100	125	150	200	250	300	400		
4100E3	Standard	600 mm	16												*
4140E3	Standard	810 mm	16												
		860 mm													

*in preparation

E3 Valve spigot ends

PN 16

No. 4100E3

No. 4140E3

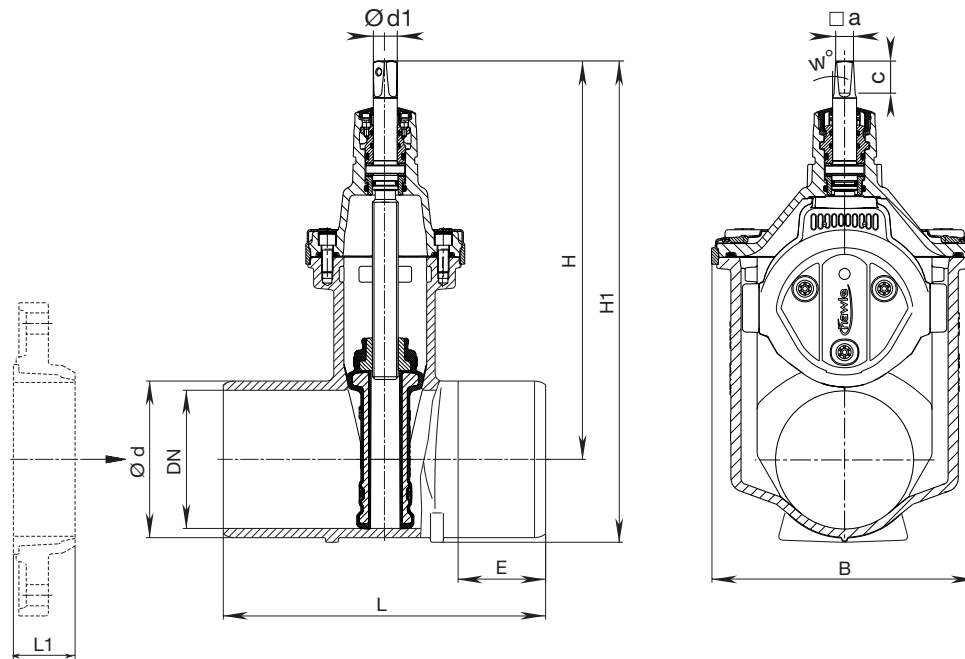

For a shorter face-to-face dimension, shorten the spigot ends¹⁾ and assemble with Hawle flanges No. 7102 / No. 0102 (see water catalogue chapter „Flange connections”)

Caution: Compare flange length „L 1” with spigot length „E”

¹⁾Protect cutting surfaces against corrosion with Hawle repair material No. 3442 (see water catalogue page P 5/2)

DN	MOP (PN)	Valve						Spindle			Weight	
		Ød*	L	E	H	H1	B	□ a	c	w°		Ød1
50	16	66	250	80	234	270	143	14,8	30	3°	20,5	8,0
65		82	270	85	305	350	180	17,3	35		24	12,0
80		98	280	85	313	366,5	180	17,3	35		24	13,5
			600	245								
100		118	300	90	343	408	213	19,3	38		24	18,0
			600	240								
125		144	325	95	421	498	285	19,3	38		26	28,5
150		170	350	95	433		523	285	19,3		38	26
			600	220		40,0						
200		222	400	115	541	657	357	24,3	48		30	55,0
			600	215								
250		274	450	120	649	792	432	27,3	48		34	91,0
			810	300								
300		326	500	120	731	897	518	27,3	48		34	139,0
	860		300	177,0								
400*	429	600	133	925	1149	687	32,3	55	44	267,0		

*in preparation

*Other outside diameters on request

A 3/2

All illustrations, technical data, dimensions (in mm) and weights (all weights specified in kg) are non-binding. Subject to change.

E3 Valve spigot ends

With flange, PN 10 | PN 16



Design features

- Resilient seated gate valve with smooth straight-through bore
- Flanges sized in accordance with EN 1092-2, drilled according to EN 1092-2 | PN 10 standard; EN 1092-2 | PN 16 DN 200 please specify on order - other standards on request
- The Hawle E3 spigot ends valve with the high-tensile loose flange system is especially suitable for use with new builds in addition to being a replacement for existing valves
- The flat gaskets are already contained in the conical seals
- Suitable for cleaning with a cleaning pig
- One extension spindle for several dimensions
- Suitable for operation by automatic actuators
- Easy retrofitting of position indicator and automatic actuators on the standard bonnet

No. 4120E3



Standard version: without handwheel and extension spindle

Suitable accessories

Suitable accessories: see page A 2/2

Handwheel:		No. 7800
Extension spindles:	rigid	No. 9000E2/E3
	telescopic	No. 9500E2/E3
Surface boxes:	rigid	No. 1750
	telescopic	No. 2050
		No. 2051K
Valve actuator:		No. 9920
Adapter for actuator (E2/E3 adapter):		No. 8630E2/E3
Base plate:	No. 3481, No. 3482	
Operating cap:	No. 2156, No. 2157, No. 2158	
Extension spindle:	No. 7820, No. 7825	
Position indicator:	No. 2170E2/E3	
Bolts:	No. 8810, No. 8830, No. 8840	
HAWAK-pillar:	No. 9894, No. 9895	

Order no.	Version	MOP (PN)	Dimensions/DN		
			100	150	200
4120E3	short EN 558 GR 14	16			

Face-to-face length EN 558 GR 15 on request

E3 Valve spigot ends

With flange, PN 10 | PN 16

No. 4120E3

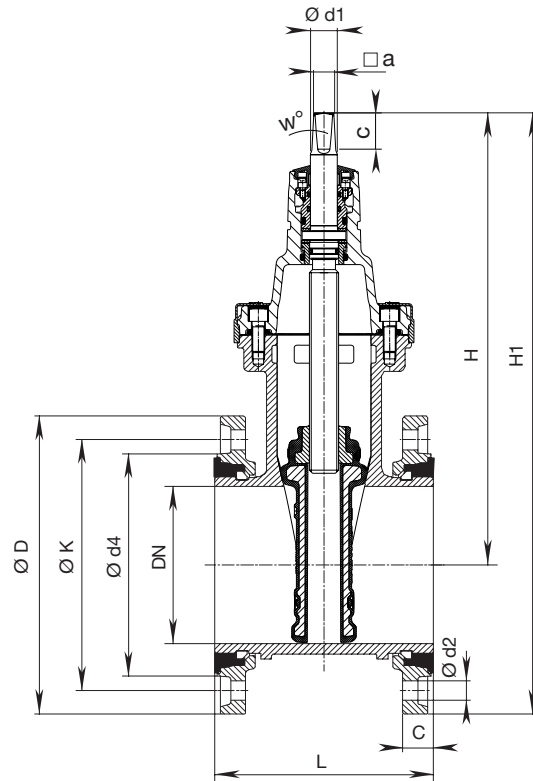

DN	MOP (PN)	Flange				Bolts			Spindle			Valve				Weight	
		$\varnothing D$	C	$\varnothing K$	$\varnothing d4$	Qty.	Thread	$\varnothing d2$	$\square a$	c	w°	$\varnothing d1$	H	H1	L		B max. width
100	10	220	19	180	153	8	M 16	19	19,3	38		24	343	453	190	213	23,5
	16																23,5
150	10	285	19	240	209	8	M 20	23	19,3	38	3°	26	433	576	210	285	40,0
	16																40,0
200	10	340	20	295	264	8	M 20	23	24,3	48		30	541	711	230	357	61,0
	16																64,0

A 3/4

All illustrations, technical data, dimensions (in mm) and weights (all weights specified in kg) are non-binding. Subject to change.

E3 Valve for PE fusion

DN 50 – 200, PN 10 | PN 16



Design features

- Resilient seated gate valve with PE fusion tails in combination with PE pipes according to EN 12201, DIN 8074
- This resilient seated valve has PE tails screwed and sealed into the sockets
- High performance sealing of the PE tails within the sockets is assured by two separate seals and a support liner
- The valve can be connected to the PE pipeline by either butt fusion or electrofusion
- One extension spindle for several dimensions
- Suitable for operation by automatic actuators
- Easy retrofitting of position indicator and automatic actuators on the standard bonnet
- Duplex stainless steel spindle

Standard version: without handwheel and extension spindle

Special versions: on request

No. 4050E3

No. 4051E3



Material | technical features

1 PE-fusion tail

Standard version PE 100-RC injection moulded

Support liner DN 50 made of POM,
from DN 65 – DN 200 made of stainless steel for PE-fusion tail(see drawing)

2 **Socket sealing** made of elastomer

3 **O-Ring** made of elastomer

Suitable accessories

Suitable accessories: see page A 2/2

Handwheel:		No. 7800
Extension spindles:	rigid	No. 9000E2/E3
	telescopic	No. 9500E2/E3
Surface boxes:	rigid	No. 1750
	telescopic	No. 2050, No. 2051K
Valve actuator:		No. 9920
Adapter for actuator (E2/E3 adapter):		No. 8630E2/E3
Base plate:		No. 3481, No. 3482
Operating cap:		No. 2156, No. 2157, No. 2158
Extension spindle:		No. 7820, No. 7825
Position indicator:		No. 2170E2/E3
HAWAK-pillar:		No. 9894, No. 9895

Order no.	MOP (PN)	Dimensions/DN Pipe Ø									
		50	65	80	100	100	125	150	150	200	200
4050E3	16	63	75	90	110	125	140	160	180	200	225
4051E3	10										

PE-fusion tail: No. 4050E3 PN 16 / SDR 11
No. 4051E3 PN 10 / SDR 17
(No. 4051E3 PN 10 / SDR 17.6 on request)

E3 Valve for PE fusion

DN 50 – 200, PN 10 | PN 16

No. 4050E3

No. 4051E3

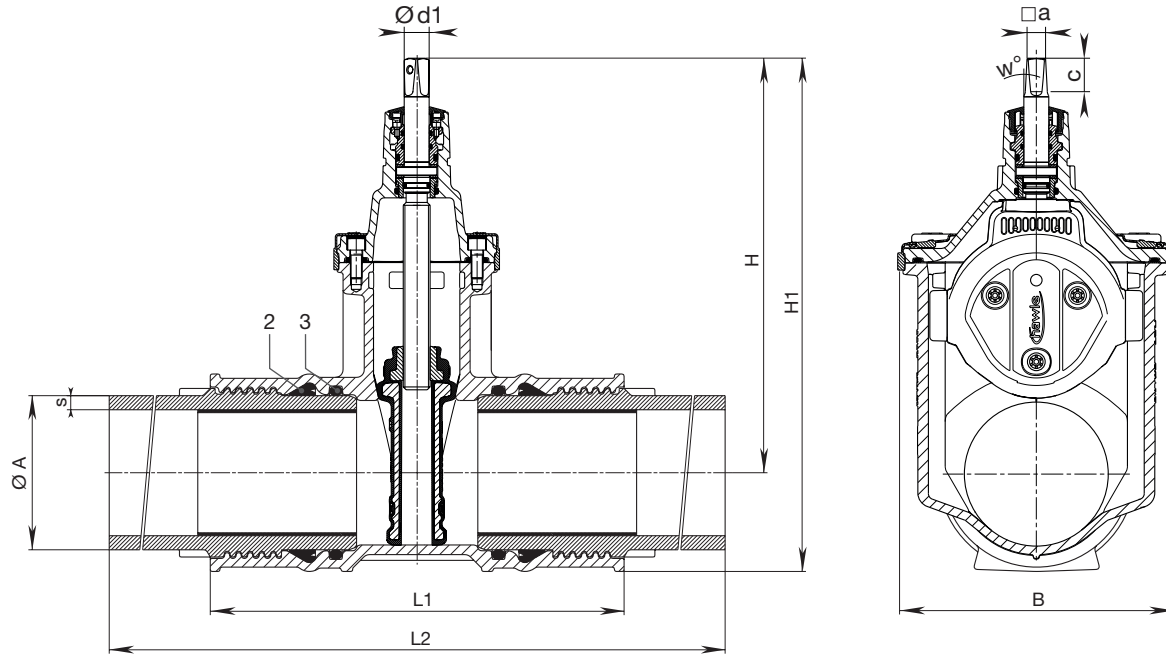

PE-fusion tail: No. 4050E3 PN 16 / SDR 11
 No. 4051E3 PN 10 / SDR 17
 (No. 4051E3 PN 10 / SDR 17.6 on request)

DN	ØA	Valve with PE tails							Spindle				Weight
		s (SDR 17)	s (SDR 11)	H	H1	L1	L2	B	□ a	c	w°	Ød1	
50	63	3,8	5,8	234	283	280	648	143	14,8	30	3°	20,5	11,0
65	75	4,5	6,8	305	361	295	657	180	17,3	35		24	17,0
80	90	5,4	8,2	313	377	310	668	180	17,3	35		24	19,0
100	110	6,6	10,0	343	419	340	710	213	19,3	38		24	26,0
100	125	7,4	11,4	343	428	395	761	213	19,3	38		24	30,5
125	140	8,3	12,7	421	513	390	756	285	19,3	38		26	31,5
150	160	9,5	14,6	433	536	430	796	285	19,3	38		26	50,0
150	180	10,7	16,4	433	548	458	814	285	19,3	38		26	57,5
200	200	11,9	18,2	541	679	514	900	357	24,3	48		30	88,0
200	225	13,4	20,5	541	679	514	900	357	24,3	48		30	90,0

E3 Valve flange | PE tail

DN 50 – 200, PN 10 | PN 16



Design features

- Resilient seated gate valve with flange and PE fusion tail in combination with PE pipes according to EN 12201, DIN 8074
- This resilient seated valve has one flange and one PE tail screwed and sealed into the sockets
- High performance sealing of the PE tails within the sockets is assured by two separate seals and a support liner
- The valve can be connected to the PE pipeline by either butt fusion or electrofusion
- Flanges sized in accordance with EN 1092-2, drilled according to EN 1092-2 | PN 10 standard; EN 1092-2 | PN 16 DN 200 please specify on order - other standards on request
- One extension spindle for several dimensions
- Suitable for operation by automatic actuators
- Easy retrofitting of position indicator and automatic actuators on the standard bonnet
- Duplex stainless steel spindle

No. 4090E3

No. 4091E3

Standard version: without handwheel and extension spindle

Special versions: on request



Material | technical features

1 PE-fusion tail

Standard version PE 100-RC injection moulded
Support liner DN 50 made of POM,
 from DN 65 – DN 200 made of
 stainless steel for PE-fusion tail
 (see drawing)

2 **Socket sealing** made of elastomer

3 **O-Ring** made of elastomer

Suitable accessories

Suitable accessories: see page A 2/2

Handwheel: No. 7800
 Extension spindles: rigid No. 9000E2/E3
 telescopic No. 9500E2/E3
 Surface boxes: rigid No. 1750
 telescopic No. 2050, No. 2051K
 Valve actuator: No. 9920
 Adapter for actuator (E2/E3 adapter): No. 8630E2/E3
 Base plate: No. 3481, No. 3482
 Operating cap: No. 2156, No. 2157, No. 2158
 Extension spindle: No. 7820, No. 7825
 Position indicator: No. 2170E2/E3
 Bolts: No. 8810, No. 8830, No. 8840
 HAWAK-pillar: No. 9894, No. 9895
 Flat gasket: No. 3390, No. 3470

Order no.	MOP (PN)	Dimensions/DN Pipe Ø								
		50	65	80	100	100	125	150	150	200
		63	75	90	110	125	140	160	180	225
4090E3	16									
4091E3	10									

PE-fusion tail: No. 4090E3 PN 16 / SDR 11
 No. 4091E3 PN 10 / SDR 17
 (No. 4091E3 PN 10 / SDR 17.6 on request)

E3 Valve flange | PE tail

DN 50 – 200, PN 10 | PN 16

No. 4090E3

No. 4091E3

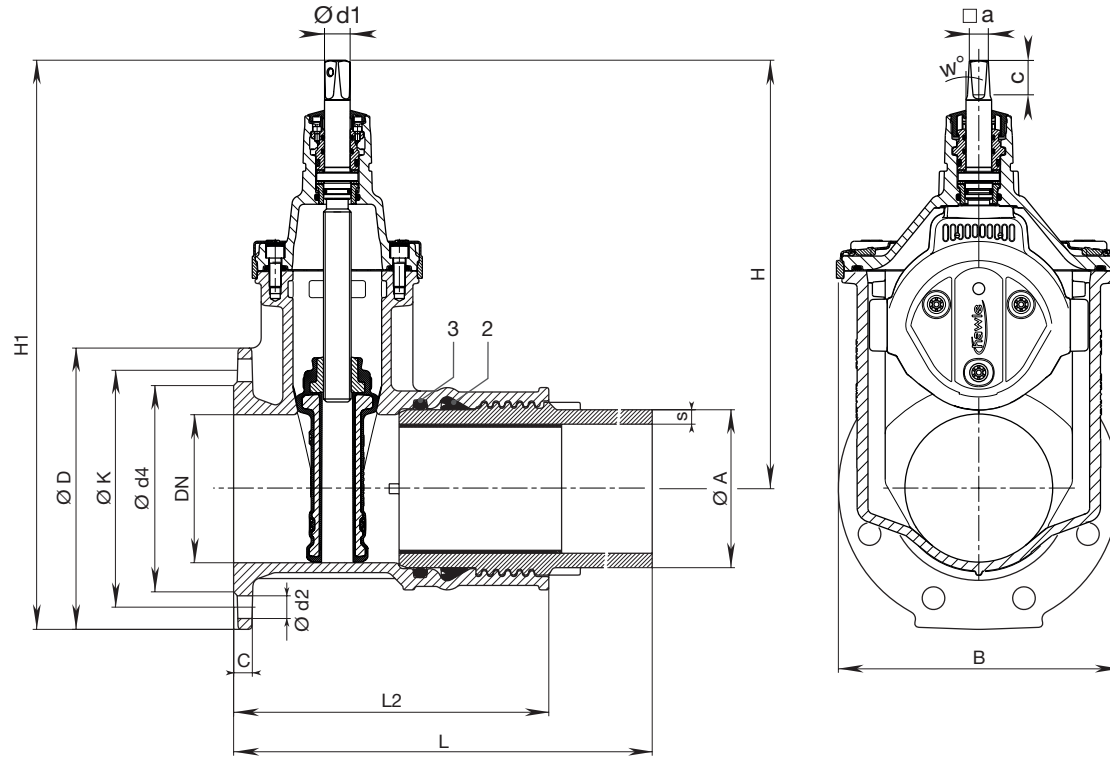

PE-fusion tail:

No. 4090E3 PN 16 / SDR 11
 No. 4091E3 PN 10 / SDR 17
 (No. 4091E3 PN 10 / SDR 17.6 on request)

DN	Ø Pipe	Flange				Bolts			Valve with PE tails						Spindle			Weight		
		ØD	C	ØK	Ød4	Qty.	Thread	Ød2	s (SDR 17)	s (SDR 11)	H	H1	L	L2	B	□ a	c		w°	Ød1
50	63	165	19	125	98	4	M 16	19	3,8	5,8	234	316	399	215	143	14,8	30	3°	20,5	11,5
65	75	185		145	118	4	M 16	19		6,8	305	397	416	235	180	17,3	35		24	17,0
80	90	200		160	133	8	M 16	19	5,4	8,2	313	413	425	245	180	17,3	35		24	18,0
100	110	220		180	153	8	M 16	19	6,6	10,0	343	453	450	265	213	19,3	38		24	25,0
100	125	220		180	153	8	M 16	19		11,4	343	453	476	293	213	19,3	38		24	26,5
125	140	250		210	183	8	M 16	19		12,7	421	546	485	310	285	19,3	38		26	38,0
150	160	285		240	209	8	M 20	23		14,6	433	576	503	320	285	19,3	38		26	44,5
150	180	285		240	209	8	M 20	23		16,4	433	576	512	334	285	19,3	38		26	49,5
200	225	340	20	295	264	8 12	M 20	23	13,4	20,5	541	711	565	372	357	24,3	48	30	78,0	

E3 VRS-socket valve

For cast iron pipes and pipes with VRS-socket,
DN 80 – 300, PN 16



Design features

- Resilient seated gate valve with one-sided VRS-socket and one-sided VRS-spigot
- With VRS grip ring and VRS pipe restraint clamp (not included), a pipe connection can be made restraint
- Suitable for cleaning with a cleaning pig
- One extension spindle for several dimensions
- Suitable for operation by automatic actuators
- Easy retrofitting of position indicator and automatic actuators on the standard bonnet
- Duplex stainless steel spindle

No. 4027E3

Standard version: without handwheel and extension spindle



Material | technical features

- 1 **Socket sealing** made of elastomer
- 2 **Pipe restraint clamp** (not included)

Suitable accessories

Suitable accessories: see page A 2/2

Handwheel:		No. 7800
Extension spindles:	rigid	No. 9000E2/E3
	telescopic	No. 9500E2/E3
Surface boxes:	rigid	No. 1750
	telescopic	No. 2050, No. 2051K
Valve actuator:		No. 9920
Adapter for actuator (E2/E3 adapter):		No. 8630E2/E3
Base plate:		No. 3481, No. 3482
Operating cap:		No. 2156, No. 2157, No. 2158
Extension spindle:		No. 7820, No. 7825
Position indicator:		No. 2170E2/E3
HAWAK-pillar:		No. 9894, No. 9895

Order no.	Version	MOP (PN)	Dimensions/DN						
			80	100	125	150	200	250	300
4027E3	Socket-Spigot	16							

E3 VRS-socket valve

For cast iron pipes and pipes with VRS-socket,
DN 80 – 300, PN 16

No. 4027E3

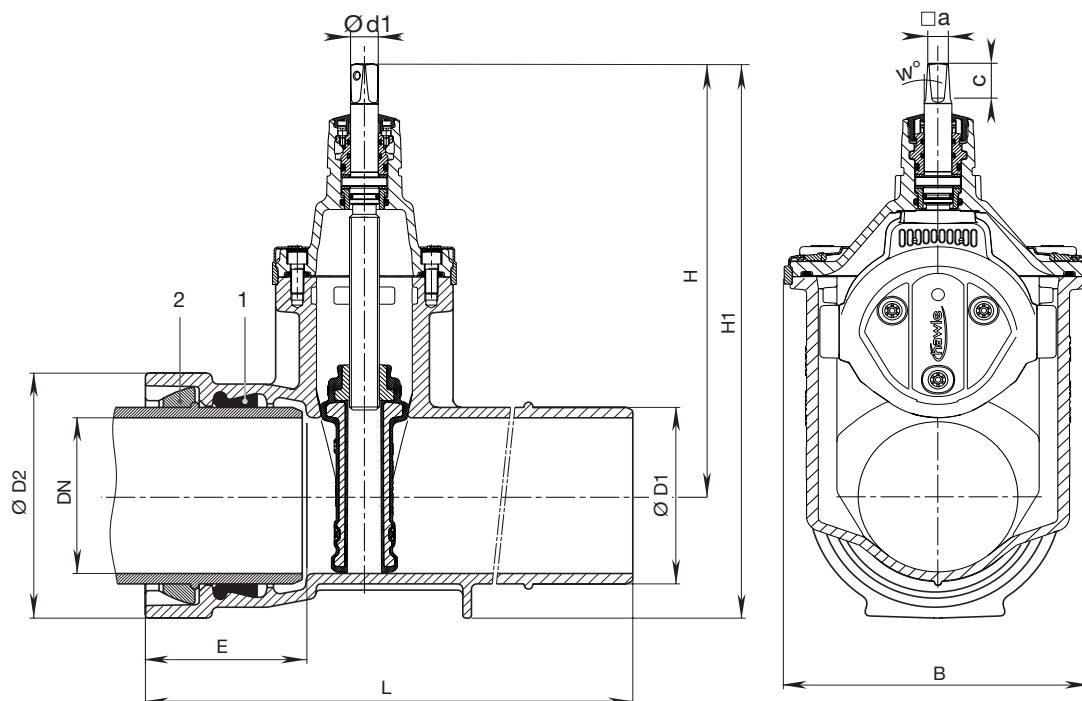

DN	Ø Pipe	MOP (PN)	Valve							Spindle				Weight
			ØD1	ØD2	E	H	H1	L	B	□ a	c	w°	Ød1	
80	98	16	98	156	127	313	391	422	180	17,3	35	3°	24	20,5
100	118		118	178	135	343	432	440	213	19,3	38		24	24,5
125	144		144	208	143	421	525	494	285	19,3	38		24	37,5
150	170		170	235	150	433	551	513	285	19,3	38		26	44,5
200	222		222	295	160	541	689	535	357	24,3	48		30	72,0
250	274		274	356	165	649	827	577	432	27,3	48		36	114,0
300	326		326	414	170	731	938	638	518	27,3	48		36	168,5

E3 Combi-T

Flange T-piece with integrated E3-valve, PN 10 | PN 16



Design features

- Resilient seated gate valve combined with flange T-piece
- Short style, equal and reduced
- Space saving installation through short design as well as savings in material, work, transport and storage costs
- The compact design enables the valve chamber to be made from sectional concrete giving typical savings of 25 % in chamber construction costs
- A combination of E3 Combi-T with E3 reducing valve creates a multitude of application possibilities
- Flanges sized in accordance with EN 1092-2, drilled according to EN 1092-2 | PN 10 standard; EN 1092-2 | PN 16 DN 200 please specify on order - other standards on request
- Suitable for cleaning with a cleaning pig
- One extension spindle for several dimensions
- Suitable for operation by automatic actuators
- Easy retrofitting of position indicator and automatic actuators on the standard bonnet
- Duplex stainless steel spindle

No. 4340E3



Standard version: without handwheel and extension spindle

Special versions: on request

Suitable accessories

Suitable accessories: see page A 2/2

Handwheel:		No. 7800
Extension spindles:	rigid	No. 9000E2/E3
	telescopic	No. 9500E2/E3
Surface boxes:	rigid	No. 1750
	telescopic	No. 2050, No. 2051K
Valve actuator:		No. 9920
Adapter for actuator (E2/E3 adapter):		No. 8630E2/E3
Base plate:		No. 3481, No. 3482
Operating cap:		No. 2156, No. 2157, No. 2158
Extension spindle:		No. 7820, No. 7825
Position indicator:		No. 2170E2/E3
Bolts:		No. 8810, No. 8830, No. 8840
Flat gasket:		No. 3390, No. 3470
HAWAK-pillar:		No. 9894, No. 9895

Order no.	MOP (PN)	Dimensions DN	Valve DN1				
			65	80	100	150	200
4340E3	16	80					
		100					
		125					
		150					
		200					

E3 Combi-T

Flange T-piece with integrated E3-valve, PN 10 | PN 16

No. 4340E3

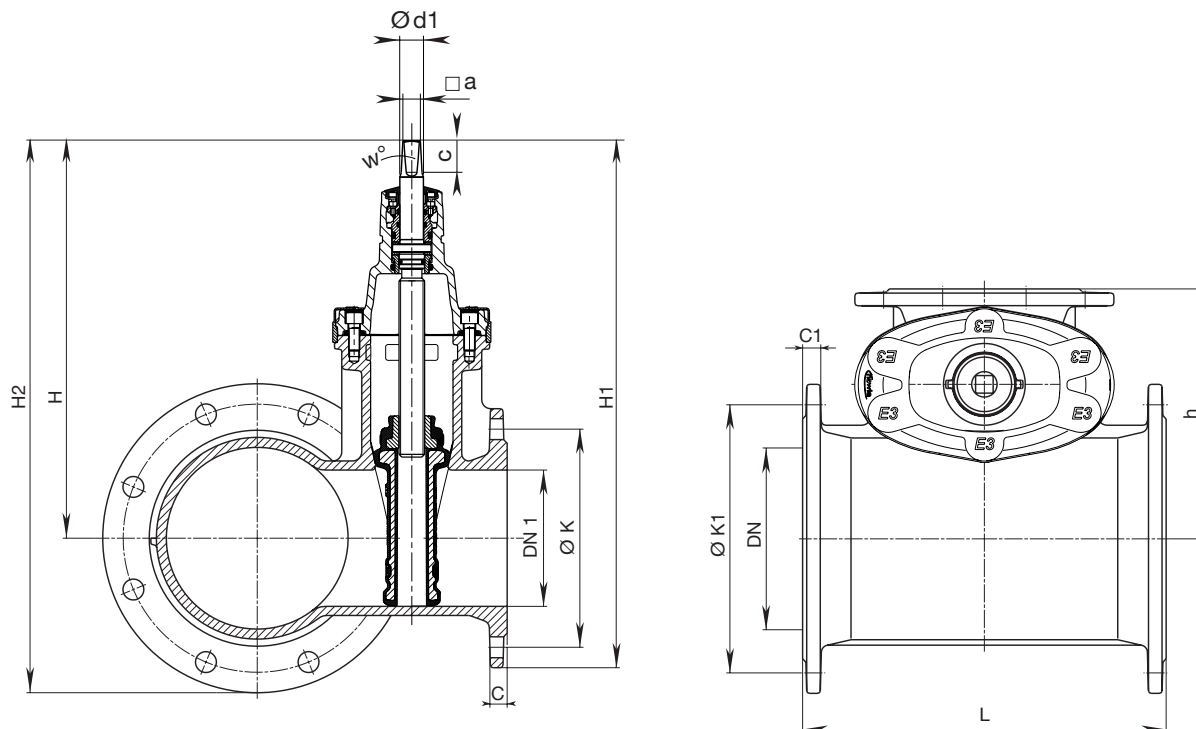

DN	DN 1 Valve	E3 Combi-T					Flange				Spindle				Weight
		L	H	H1	H2	h	ØK	C	ØK1	C1	□ a	c	w°	Ød1	
80	80	280	313	413	413	170	160	19	160	19	17,3	35	3°	24	24,0
100	65	260	305	397	408	180	145	19	180	19	17,3	35		24	29,5
100	80	280	313	413	416	200	160	19	180	19	17,3	35		24	30,0
100	100	310	343	453	453	200	180	19	180	19	19,3	38		24	34,0
125	80	280	313	413	432	200	160	19	210	19	17,3	35		24	30,5
125	100	310	343	453	469	215	180	19	210	19	19,3	38		24	36,5
150	65	260	305	397	441	210	145	19	240	19	17,3	35		24	33,0
150	80	280	313	413	444	220	160	19	240	19	17,3	35		24	36,0
150	100	310	343	453	487	220	180	19	240	19	19,3	38		24	40,5
150	150	400	433	576	576	250	240	19	240	19	19,3	38		26	55,5
200	80	280	313	413	484	250	160	19	295	20	17,3	35	24	43,0	
200	100	310	343	453	521	250	180	19	295	20	19,3	38	24	49,5	
200	150	400	433	576	610	275	240	19	295	20	19,3	38	26	68,5	
200	200	460	541	711	711	295	295	20	295	20	24,3	48	30	90,0	

E3 Combi-III

Flanged T-piece with 3 flanged outlets and 2 or 3 integral E3 valves, PN 10 | PN 16



Design features

- Resilient seated gate valve combined with flange-T-piece
- Space saving installation through short design as well as savings in material, work, transport and storage costs
- The compact design enables the valve chamber to be made from sectional concrete giving typical savings of 25 % in chamber construction costs
- Vertical connection DN 100 optional
- Internal thread connection 3/4" - optional for manometer, ball valve outlet etc.
- Flanges sized in accordance with EN 1092-2, drilled according EN 1092-2 | PN 10 standard; EN 1092-2 | PN 16 DN 200 please specify on order - other standards on request
- Suitable for cleaning with a cleaning pig
- Duplex stainless steel spindle

No. 4450E3

No. 4460E3



Suitable accessories

Suitable accessories: see page A 2/2

- Handwheel: No. 7800
- Extension spindles: rigid No. 9000E2/E3
telescopic No. 9500E2/E3
- Surface box: No. 4550
- Operating cap: No. 2156, No. 2157, No. 2158
- Extension spindle: No. 7820, No. 7825
- Position indicator: No. 2170E2/E3
- Bolts: No. 8810, No. 8830, No. 8840
- Flat gasket: No. 3390, No. 3470
- Blanking cap: No. 8570E2/E3

Instead of a bonnet, a cap No. 8570E2/E3 can be fitted onto the body of any outlet not requiring a valve



Please specify the arrangement of the valves in a clockwise direction!

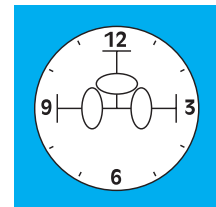

Order no.	Version	MOP (PN)	No. of valves	Dimensions/DN				
				80	100	125	150	200
4450E3	Without vertical centre outlet	16	2					
			3					
4460E3	With vertical outlet		2					
			3					

E3 Combi-III

Flanged T-piece with 3 flanged outlets and 2 or 3 integral E3 valves, PN 10 | PN 16

No. 4450E3

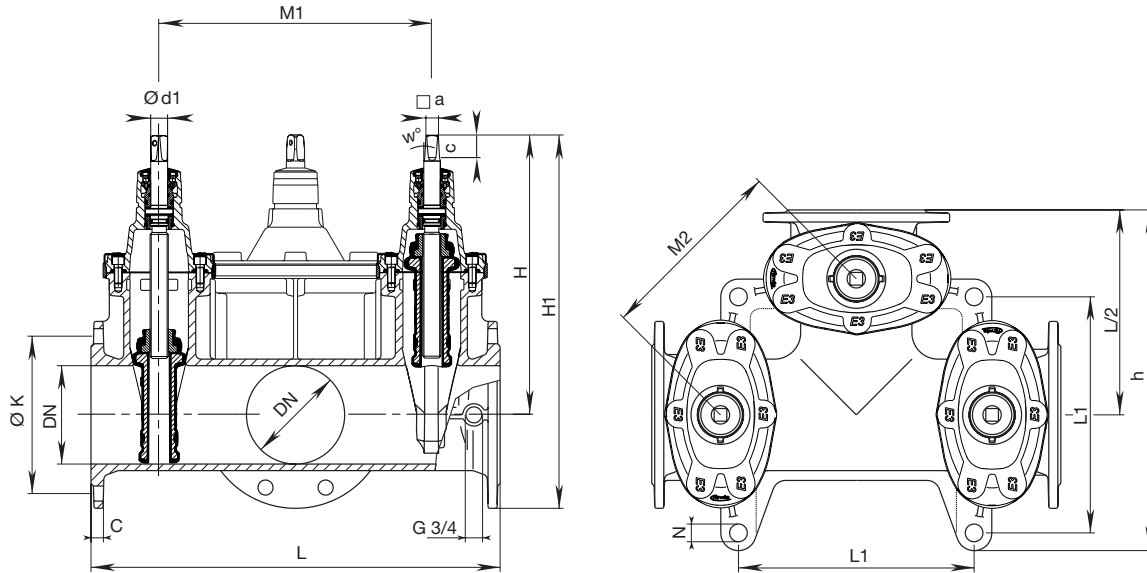

DN	E3 Combi III without vertical centre outlet										Spindle				Weight (no. of valves)	
	L	H	H 1	ØK	C	M1	M2	L1	h	N	a	c	w°	Ød1	2	3
80	435	313	413	160	19	255	180	-	318	-	17,3	35		24	45,0	47,0
100	555	343	453	180	19	365	258	212	411	27	19,3	38		24	68,0	67,0
125	615	421	571	210	19	415	294	360	515	27	19,3	38	3°	26	101,0	153,0
150	625	433	576	240	19	415	294	360	520	27	19,3	38		26	105,0	114,5
200	695	541	711	295	20	465	329	445	602	32	24,3	48		30	167,0	183,0

No. 4460E3

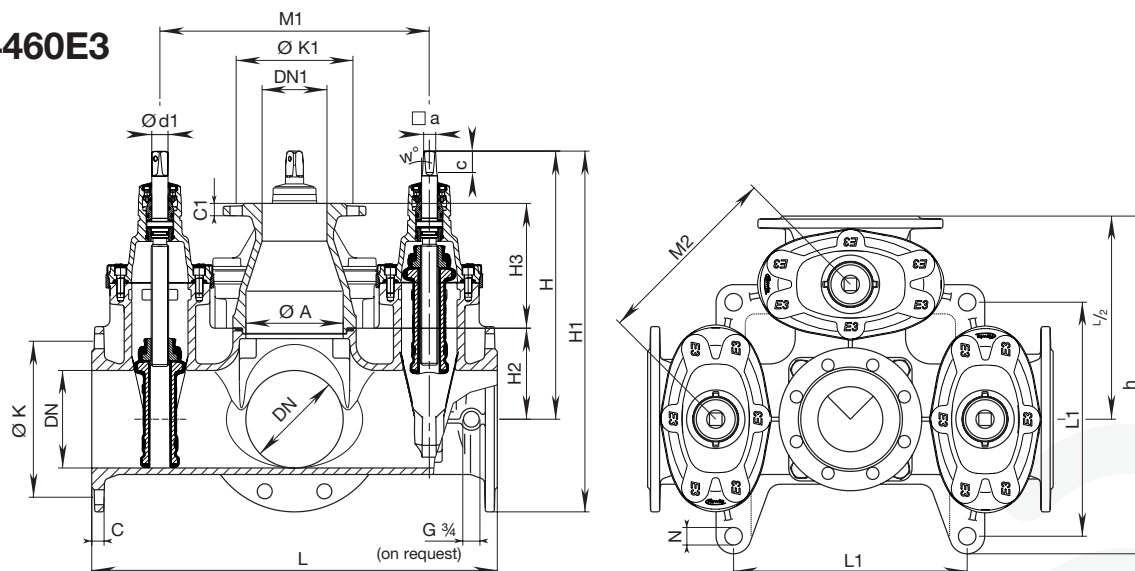

DN	E3 Combi III with vertical centre outlet													Spindle				E3 Combi III with vertical centre outlet				
	ØA	DN 1	L	L1	H	H1	H2	H3	C	C1	ØK	ØK1	M1	M2	h	N	a	c	w°	Ød1	2	3
100	100	100	555	212	343	453	90	+	19	+	180	+	365	258	411	27	19,3	38		24	71,0	76,0
150	150	100	625	360	433	576	140	192	19	19	240	180	415	293,5	520	27	19,3	38	3°	26	120,0	130,0
200	200	100	695	445	541	711	180	192	20	19	295	180	465	329	602	32	24,3	48		30	198,0	205,0

+ flange connection directly on the body - stud

A 7/2

All illustrations, technical data, dimensions (in mm) and weights (all weights specified in kg) are non-binding. Subject to change.

E3 Combi-IV



Flanged T-piece with 4 flanged outlets and 2, 3 or 4 integral E3 valves, PN 10 | PN 16

Design features

- Resilient seated gate valve combined with flange cross piece
- Space saving installation through short design as well as savings in material, work, transport and storage costs
- The compact design enables the valve chamber to be made from sectional concrete giving typical savings of 25 % in chamber construction costs
- Vertical connection DN 100 optional
- Internal thread connection 3/4" - optional for manometer, ball valve outlet etc.
- Flanges sized in accordance with EN 1092-2, drilled according EN 1092-2 | PN 10 standard; EN 1092-2 | PN 16 DN 200 please specify on order - other standards on request
- Suitable for cleaning with a cleaning pig
- Duplex stainless steel spindle

No. 4400E3

No. 4410E3



Instead of a bonnet, a cap No. 8570E2/E3 can be fitted onto the body of any outlet not requiring a valve

Suitable accessories

Suitable accessories: see page A 2/2

Handwheel:		No. 7800
Extension spindles:	rigid	No. 9000E2/E3
	telescopic	No. 9500E2/E3
Surface box:		No. 4550
Operating cap:		No. 2156, No. 2157, No. 2158
Extension spindle:		No. 7820, No. 7825
Position indicator:		No. 2170E2/E3
Bolts:		No. 8810, No. 8830, No. 8840
Flat gasket:		No. 3390, No. 3470
Blanking cap:		No. 8570E2/E3



No. 4410E3 cross connection with 3 valves and vertical centre outlet



With 3 valves and no vertical outlet

Please specify the arrangement of the valves in a clockwise direction!

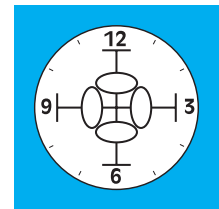

Order no.	Version	MOP (PN)	No. of valves	Dimensions/DN				
				80	100	125	150	200
4400E3	Without vertical centre outlet	16	2					
			3					
			4					
4410E3	With vertical outlet	16	3					
			4					

E3 Combi-IV

Flanged T-piece with 4 flanged outlets and 2, 3 or 4 integral E3 valves, PN 10 | PN 16

No. 4400E3

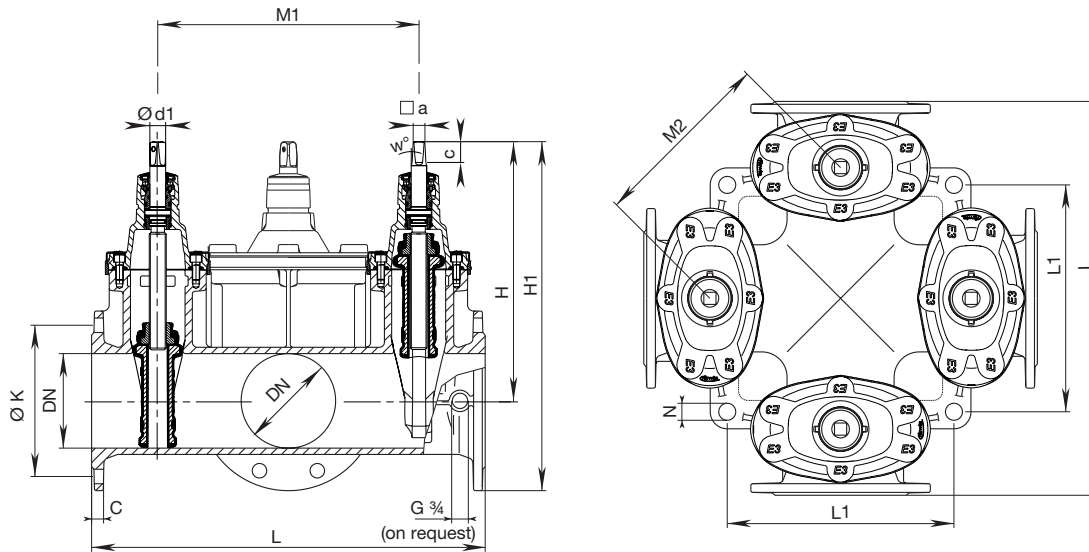

DN	E3 Combi IV without vertical centre outlet									Spindle				Weight (no. of valves)		
	L	H	H1	ØK	C	M1	M2	L1	N	a	c	w°	Ød1	2	3	4
80	435	313	413	160	19	255	180			17,3	35	3°	24	55,0	60,0	65,0
100	555	343	453	180	19	365	258	212	27	19,3	38		24	76,0	84,0	90,0
125	615	421	571	210	19	415	293,5	360	27	19,3	38		26	125,0	135,0	139,0
150	625	433	576	240	19	415	293,5	360	27	19,3	38		26	135,0	143,0	151,0
200	695	541	711	295	20	465	329	445	32	24,3	48		30	207,0	223,0	238,0

No. 4410E3

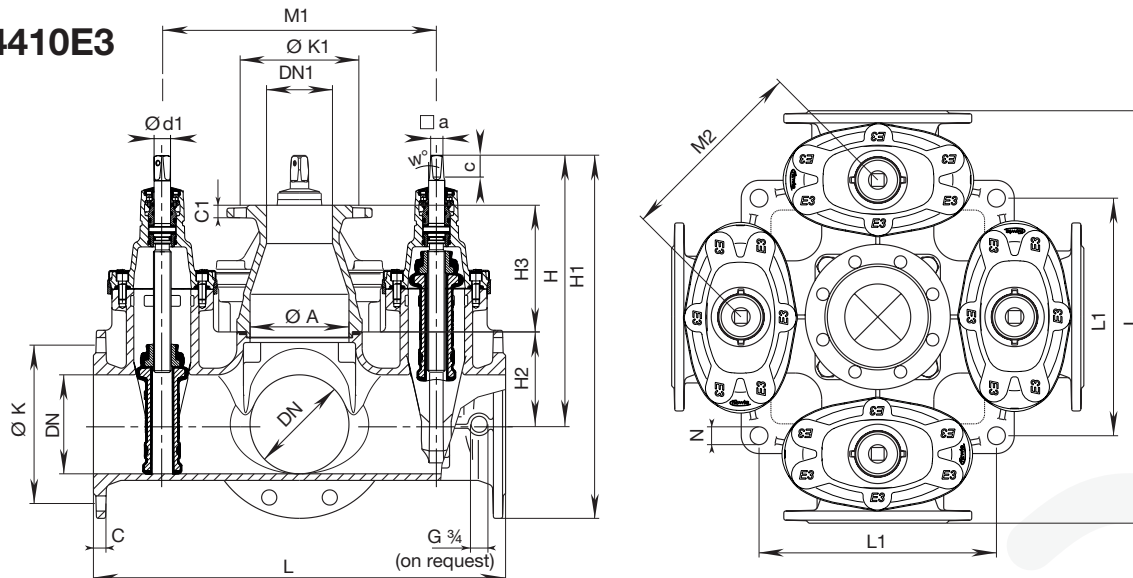

DN	E3 Combi IV with vertical centre outlet											Spindle				Weight (no. of valves)					
	ØA	DN1	L	L1	H	H1	H2	H3	C	C1	ØK	ØK1	M1	M2	N	a	c	w°	Ød1	3	4
100	100	100	555	212	343	453	90	+	19	+	180	+	365	258	27	19,3	38	3°	24	90,0	96,0
150	150	100	625	360	433	576	140	192	19	19	240	180	415	293,5	27	19,3	38		26	154,0	164,0
200	200	100	695	445	541	711	180	192	20	19	295	180	465	329	32	24,3	48		30	265,0	

+ flange connection directly on the body - stud

E3 Hawle-Combiflex

DN 150, PN 10 | PN 16



Design features

- Modular Combi-valve system enables flexible assembly arrangements
- Standardized compact construction regardless of valve configuration
- Suitable for cleaning with a cleaning pig
- Comprehensive range of interchangeable ZAK connections possible in every module
- Unique design facilitates easy, rapid exchange of any module
- Duplex stainless steel spindle

Material | technical features

- 1 Resilient seated E3 valve according to EN 1074-1 and 1074-2
- 3 Molybdenum coated, A4 type clamping ring bolts
- 4/11 ZAK-46 (4) or ZAK-34 (11) socket for corrosion-free connection of sensors or ZAK Service valve
- 2/5/7/ 9/10 Hawle Combiflex vertical outlet (2) optionally
- DN 80 or DN 100 end cap (5), clamping ring (7), middle section DN 150 (9), E3 body (10) reduced in DN 80, DN 100, DN 125; DN 150; or expanded to DN 200: ductile iron, epoxy powder coated
- 6 HAWLE-COMBIFLEX mounting frame: ductile iron, epoxy powder coated, with ring bolts for fastening hoists and integrated rings for floor connections
- 8 Quality inspection seal
- 12 Operating cap made of aluminum, including covering cap with direction indicator
- 13 Vertical outlet with affixed flat elastomer gasket
- 14 Outlet ET 1", optional (not installed)
- 15 Anchoring system, optional

No. 4420E3

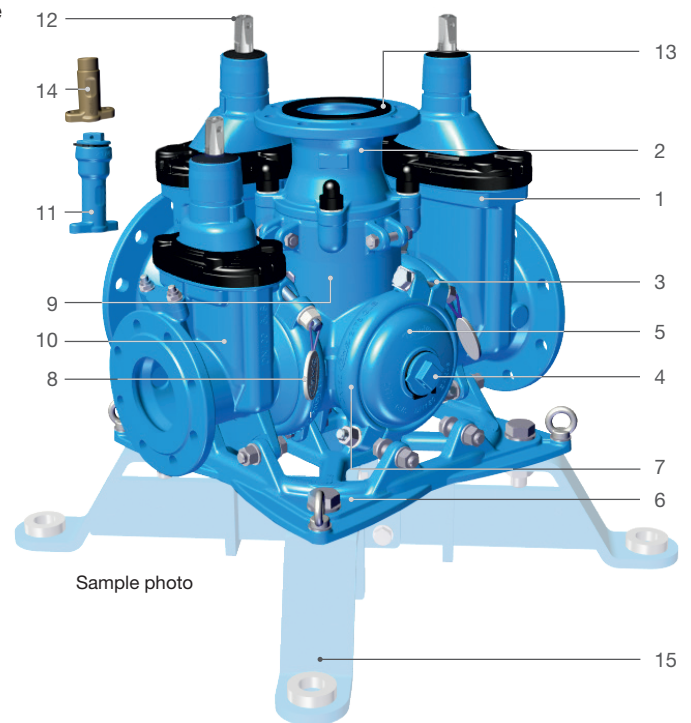

Sample photo

Suitable accessories

- Suitable accessories:** see page A 2/2
- Handwheel: No. 7800
 - Extension spindles: rigid No. 9000E2/E3
telescopic No. 9500E2/E3
 - Surface boxes: rigid No. 1750
telescopic No. 2050, No. 2051K
 - Operating cap: No. 2156, No. 2157, No. 2158
 - Extension spindle: No. 7820, No. 7825
 - Bolts: No. 8810, No. 8830, No. 8840
 - Ground-distance sets: No. 8644
 - Flat gasket: No. 3390, No. 3470
 - Operating cap: No. 2157, No. 2158
 - ET 1" outlet: No. 6979
 - ZAK 34 outlet: No. 6979
 - ZAK 34 plug: No. 6980
 - Blanking cap: No. 8570E2/E3

Individual combination options see page A 9/3

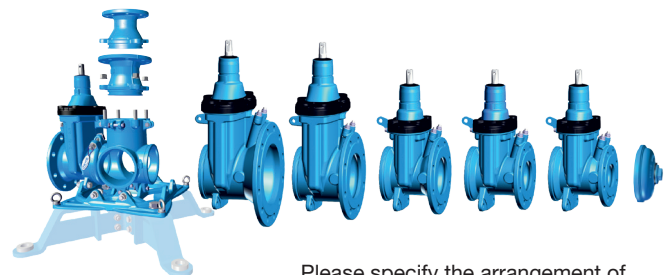

Please specify the arrangement of the valves in a clockwise direction!

Order no.	Version	MOP (PN)	Dimensions / DN	Possible reduction / DN	Possible vertical outlet / DN	Weight min. – max.
4420E3	Individually configurable	10/16	150	80	80/100	57 – 212
				100		
				125		
				150		
				200		

Flange sized and drilled in accordance with EN 1092-2 standard PN 10. Please specify PN 16 when ordering. Standard version inclusive operating caps (remove in case of actuation by extension spindle or handwheel!) Please use the HAWLE-COMBIFLEX order form. It can be found on our homepage.

E3 Hawle-Combiflex

DN 150, PN 10 | PN 16

No. 4420E3

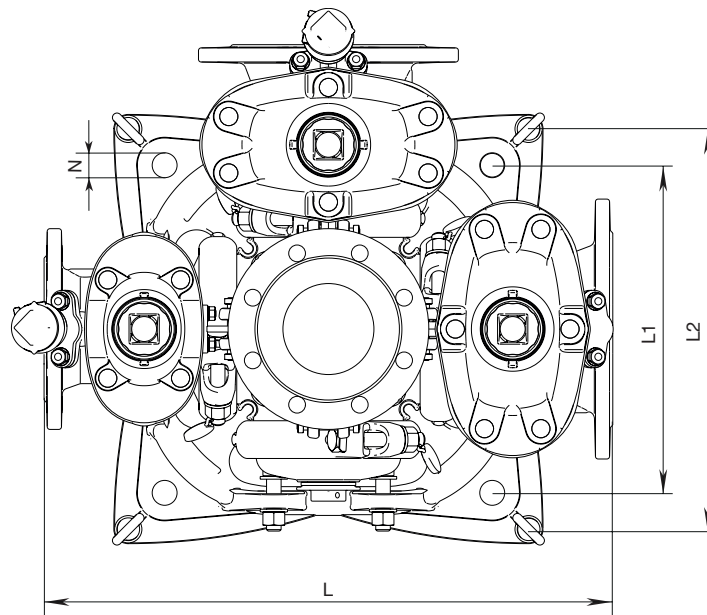
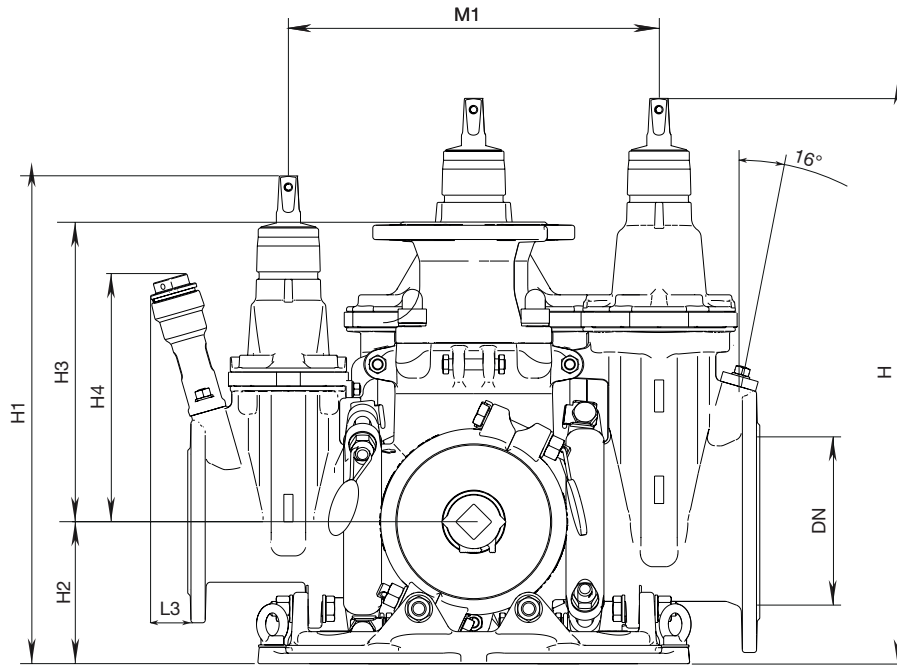

DN	E3 Hawle-Combiflex												
	MOP (PN)	DN	L*	L1	L2	L3	H	H1	H2	H3	H4	M1*	ØN
150	10/16	80	625	360	440	37	609	518	155	328	262	405	27,4
		100				40					271		
		125				38					284		
		150				40					298		
		200*				24					335		

*The external dimensions (L, M1) remain the same with reducing valves!
 * height compensation due to flange necessary
 #Transport dimensions = L

E3 Hawle-Combiflex

Individual parts DN 150

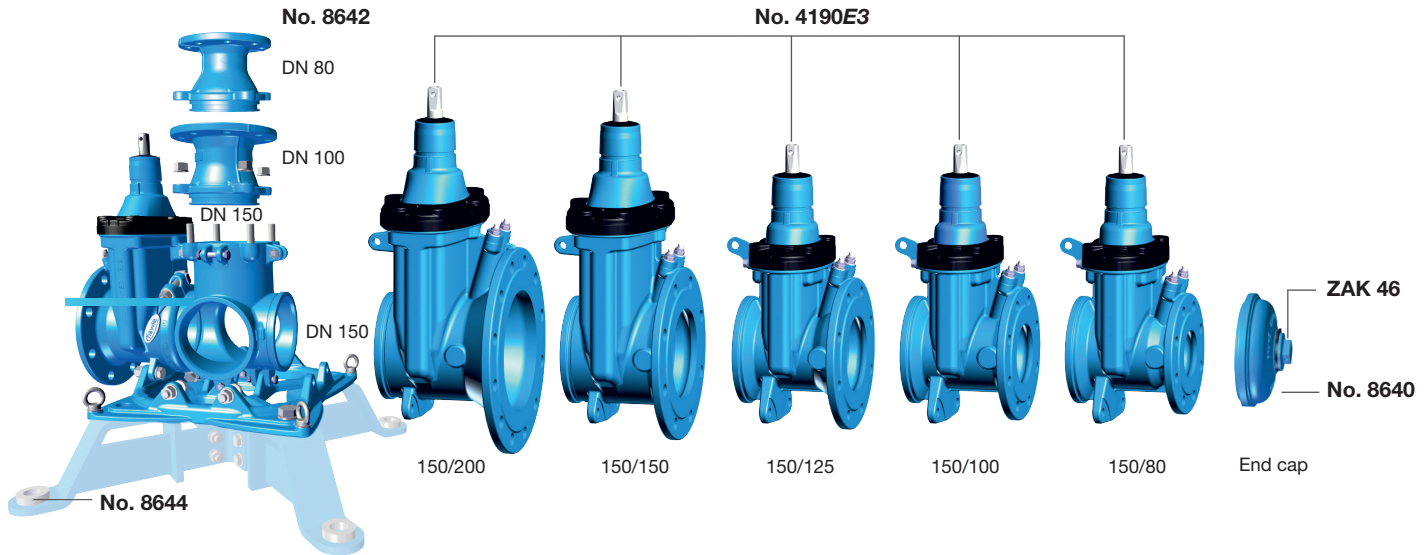

No. 4190E3

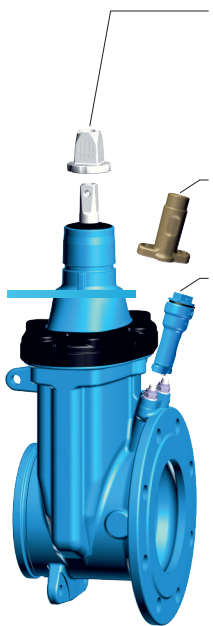

Optional
Operating cap
 Order-No. 2156
 Order-No. 2157
 Order-No. 2158

Optional
Outlet ET 1"
 Order-No. 6979

Optional
ZAK 34 outlet
 Order-No. 6979
ZAK-plug
 Order-No. 6980

- Incl. bolt fastener for the middle section
- Fits through manhole openings

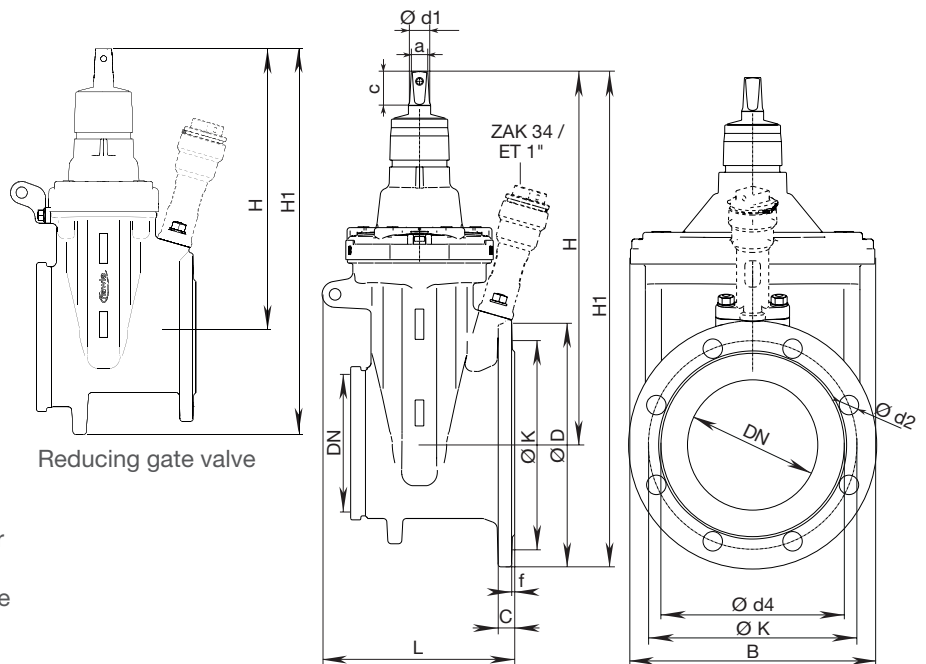

DN	Hawle-Combiflex E3 gate valve																			
	Flange							Bolts			Spindle			Valve						
	DN	MOP (PN)	Ø D*	C	Ø K	Ø d4	f	Qty.	Thread	Ø d2	a	c	Ø d1	Wedge DN	Service outlet	H	H1*	L*	B*	~ Max. weight
150	80	10 16	200	19	160	133		8	M16	19			25	100	ZAK 34 ET 1"	343	453	258	213	21,8
	100	10 16	220	19	180	153		8	M16	19			25	100		343	453	261	213	22,5
	125	10 16	250	19	210	183	3	8	M16	19	19,3	38	25	100		343	468	259	213	23,7
	150	10 16	285	19	240	209		8	M20	23			28	150		433	576	262	283	34,7
	200	10 16	340	20	295	264		8 12	M20	23			28	150		433	603	281	283	40,0

* Transport dimensions

E3 Hawle-Combiflex

Individual parts DN 150

Hawle-Combiflex end cap No. 8640



- ZAK 69 socket

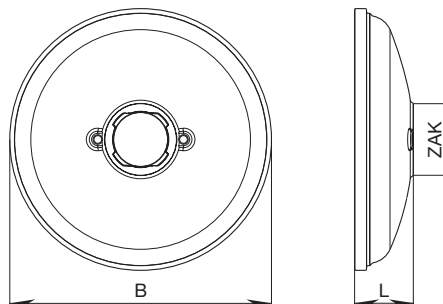

DN	Hawle-Combiflex end cap			
	B	ZAK-socket	L	Weight
150	177	ZAK 46	47	2,5

Hawle-Combiflex vertical outlet No. 8642



- Incl. affixed elastomer flange gasket

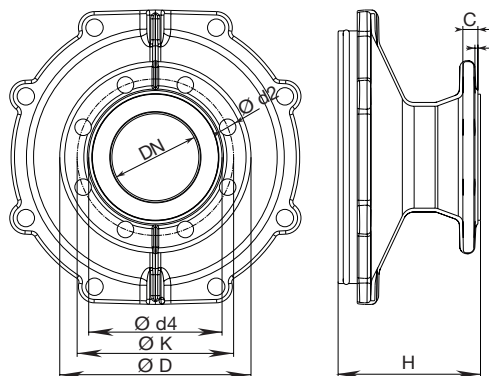

DN	Hawle-Combiflex vertical outlet											
	Flange							Bolts			Vertical outlet	
	DN	MOP (PN)	Ø D	C	Ø K	Ø d4	f	Qty.	Thread	Ø d2	H	Weight
150	80	10/16	200	19	160	133	3	8	M16	19	155	7,0
	100	10/16	220	19	180	153	3	8	M16	19	155	8,0

Blanking cap No. 8570E2/E3



- For combi valves in place of valve bonnet
- Made of ductile iron, epoxy powder coated without screws and hood seal

Order No.	DN	Weight
8570E2/E3	80	1,6
	100	1,9
	125 – 150	3,2
	200	5,0

Hawle-Combiflex ground-distance set No. 8644 (order separately)

Stainless steel

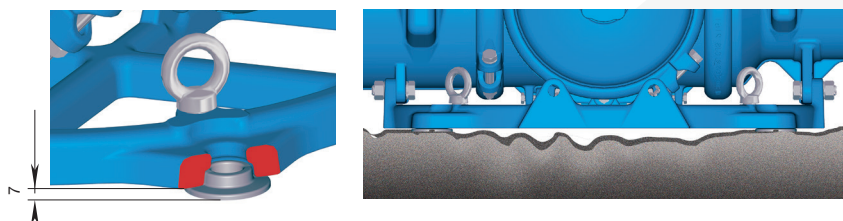
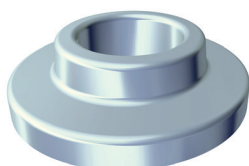

A 9/4

All illustrations, technical data, dimensions (in mm) and weights (all weights specified in kg) are non-binding. Subject to change.

E3 Hawle-Combiflex

DN 250 / DN 300, PN 10 | PN 16



Design features

- Modular Combi-valve system enables flexible assembly arrangements
- Standardized compact construction regardless of valve configuration
- Suitable for cleaning with a cleaning pig
- Comprehensive range of interchangeable ZAK connections possible in every module
- Unique design facilitates easy, rapid exchange of any module
- Duplex stainless steel spindle

No. 4420E3

Material | technical features

- 1 Resilient seated E3 valve in DN 150 to DN 400 according to EN 1074-1 and 2
- 3 Molybdenum coated, A4 type clamping ring bolts
- 4/11 ZAK-69 (4) or ZAK-46 (11) socket for corrosion-free connection of sensors or ZAK Service valve
- 2/5/7/ Hawle-Combiflex vertical outlet (2) optionally
- 9/10 DN 100 or DN 150 end cap (5), clamping ring (7), 2 types of middle section DN 250 or DN 300 (9), E3 body (10) reduced in DN 150 and DN 200 or expanded to DN 400: ductile iron, epoxy powder coated
- 6 Hawle-Combiflex mounting frame: ductile iron, epoxy powder coated, with ring bolts for fastening hoists and integrated rings for floor connections
- 8 Quality inspection seal
- 12 Operating cap made of aluminum, including covering cap with direction indicator
- 13 Vertical outlet with affixed flat elastomer gasket
- 14 Assembly fittings kit (4 items each: plastic support liner; hot-dip galvanized spacer disk; hot-dip galvanized washer)
- 15 Anchoring system, optional

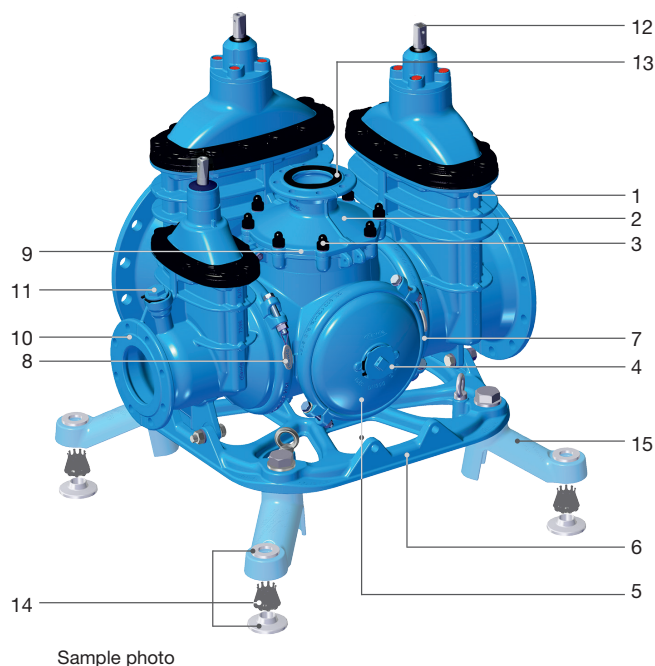

Sample photo

Individual combination options see page A 9/7

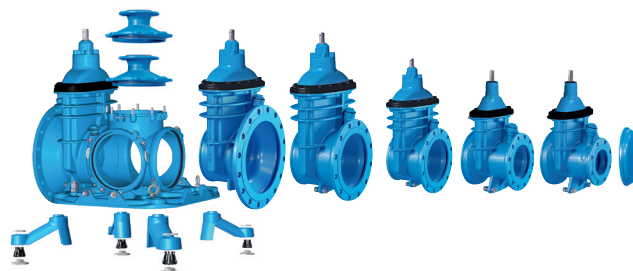

Suitable accessories

Suitable accessories: see page A 2/2

- Handwheel: No. 7800
- Extension spindles: rigid No. 9000E2/E3
telescopic No. 9500E2/E3
- Surface boxes: rigid No. 1750
telescopic No. 2050, No. 2051K
- Operating cap: No. 2156, No. 2157, No. 2158
- Extension spindle: No. 7820, No. 7825
- Bolts: No. 8810, No. 8830, No. 8840
- Assembly fittings kit: No. 8647
- Flat gasket: No. 3390, No. 3470
- Blanking cap: No. 8570E2/E3

Order no.	Version	MOP (PN)	Dimensions / DN	Possible reduction / DN	Possible vertical outlet / DN	Weight min. - max.
4420E3	Individually configurable	10	250	150	100	265 – 465
				200	150	
		16	300	150	100	330 – 706
				200		
				250	150	
				300		
		400				

Flange sized and drilled in accordance with EN 1092-2 standard PN 10. Please specify PN 16 when ordering. Standard version including operating cap (to be removed during operation using extension spindle or hand wheel!) Please use the HAWLE-COMBIFLEX order form. It can be found on our homepage.

E3 Hawle-Combiflex

DN 250 / DN 300, PN 10 | PN 16

No. 4420E3

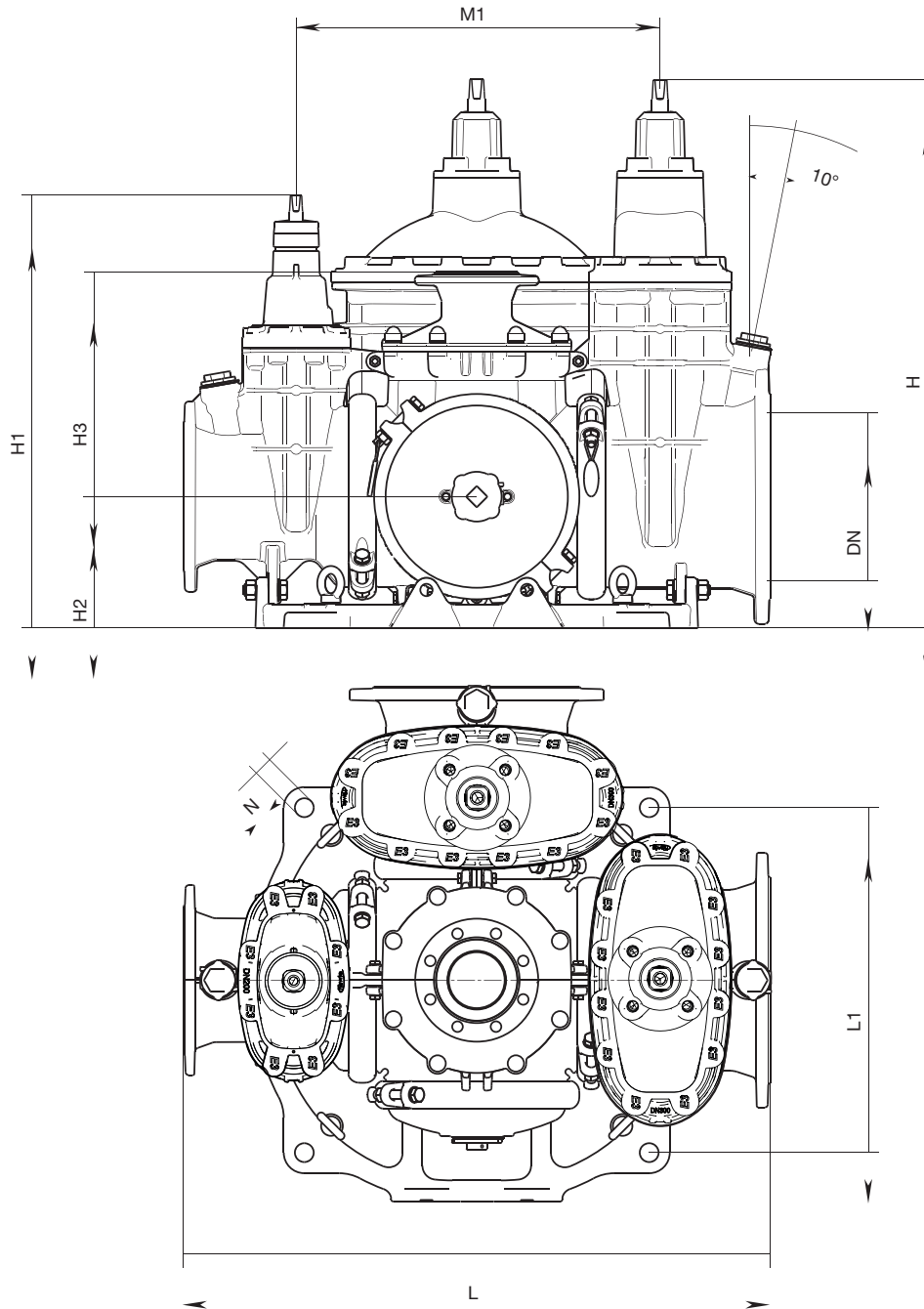

DN	Hawle-Combiflex									
	MOP (PN)	L*	L1	H	H1	H2	H3	DN	M1*	ØN
250	10	960	617	911	755	210	359	150	590	34
	16							200		
	250									
300	10	1050	617	1021	809	235	399	150	646	34
	16							200		
	250									
	300									
								400		

*The external dimensions (L, M1) remain the same with reducing valves!

E3 Hawle-Combiflex

Individual parts DN 250 / DN 300

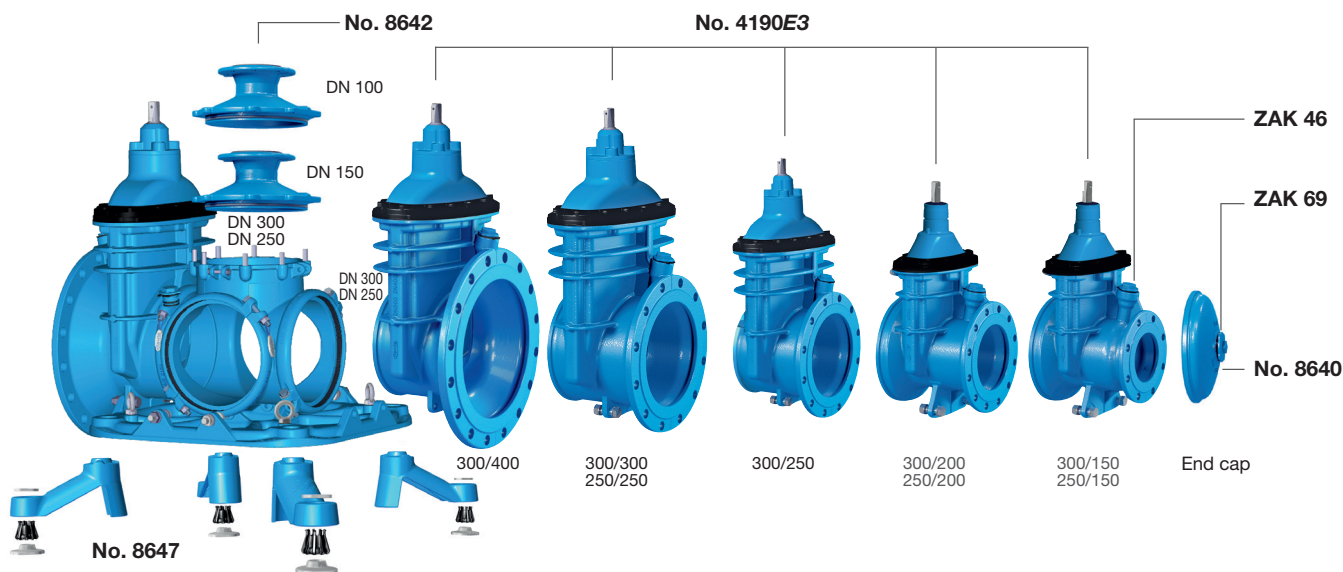

Hawle-Combiflex E3 gate valve No. 4190E3

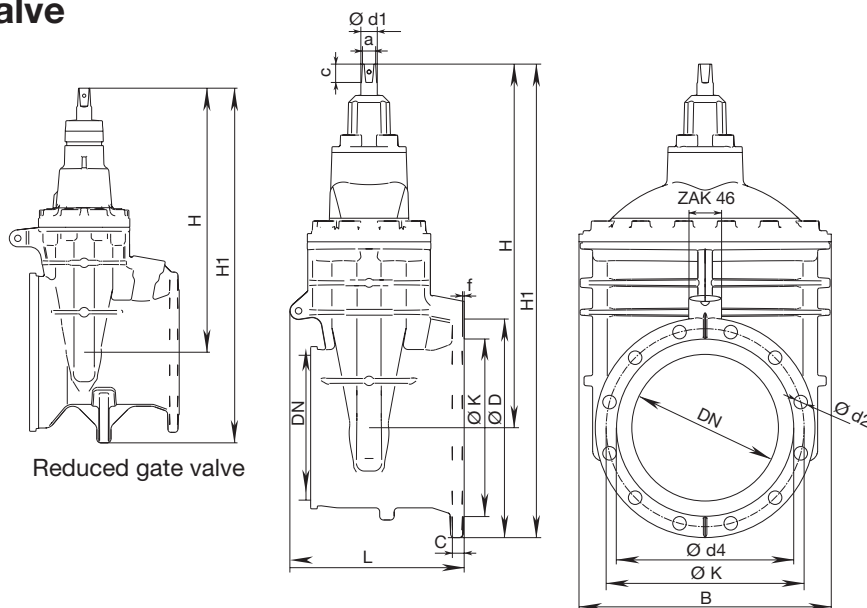

Hawle-Combiflex E3 gate valve																		
DN	Flange					Bolts		Spindle				Valve						
	DN	MOP (PN)	Ø D	C	Ø K	Qty.	Thread	Ø d2	a	c	Ø d1	Wedge DN	Service outlet	H	H1*	L*	B*	Weight
250	150	10 16	285	19	240	8	M20	23	24,3	48	32	200	ZAK 46	541	707	337	356	61,0
	200	10 16	340	20	295	8 12	M20	23	24,3	48	32	200		541	710	337	356	62,0
	250	10 16	400	22	350 355	12	M20 M24	23 28	27,3	48	34	250		649	850	337	438	89,0
300	150	10 16	285	19	240	8	M20	23	24,3	48	32	200		541	734	361	356	65,0
	200	10 16	340	20	295	8 12	M20	23	24,3	48	32	200		541	734	361	356	66,0
	250	10 16	400	22	350 355	12	M20 M24	23 28	27,3	48	34	250		649	850	361	438	93,0
	300	10 16	455	24,5	400 410	12	M20 M24	23 28	27,3	48	34	300		731	960	361	523	132,0
	400*	10 16	580	28	515 525	16	M24 M27	28 31	27,3	48	34	300		731	1030	361	523	146,0

* Transport dimensions

*height adjustment necessary due to flange sheet

Notes



E3 Hawle-Combiflex

Individual parts DN 250 / DN 300



Hawle-Combiflex end cap No. 8640



- ZAK 69 socket

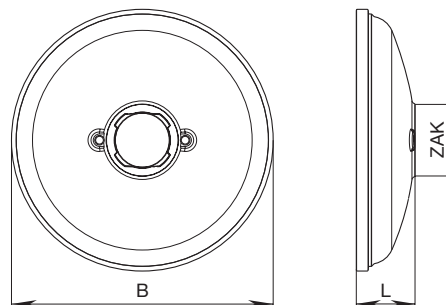

DN	Hawle-Combiflex end cap			
	B	ZAK-socket	L	Weight
250	284	ZAK 69	67	6,0
300	335	ZAK 69	77	7,5

Hawle-Combiflex vertical outlet No. 8642



- Incl. affixed elastomer flange gasket

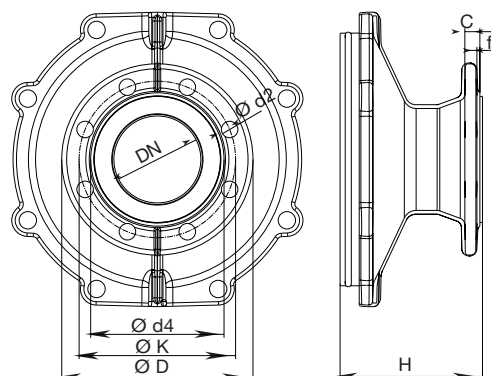

DN	Hawle-Combiflex vertical outlet											
	Flange						Bolts			Vertical outlet		
	DN MOP (PN)	Ø D	C	Ø K	Ø d4	f	Qty.	Thread	Ø d2	H	Weight	
250	100	10/16	220	19	180	153	3	8	M16	19	146	12,0
	150	10/16	285	19	240	209	3	8	M20	23	146	11,0
300	100	10/16	220	19	180	153	3	8	M16	19	160	13,0
	150	10/16	285	19	240	209	3	8	M20	23	160	13,0

Blanking cap No. 8570E2/E3



DN 150 – 200

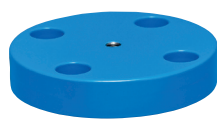

DN 250 – 300

Order No.	DN	Weight
8570E2/E3	150	3,2
	200	5,0
	250 – 300	5,0

- For combi valves in place of valve bonnet
- Made of ductile iron, epoxy powder coated without screws and hood seal

Notes



Hawle-E1+ gate valve

Overview



Design features

- Resilient seated gate valve according to EN 1074-1 and EN 1074-2 with smooth, straight bore
- Flanged valve, short face-to-face dimension
- Wedge guide with high glide characteristics; load-optimised design guarantees very low wear and closing torques
- Wedge nut resists high torque load due to its larger size with more than the required thread length
- Spindle bearing attached in bonnet by bayonet connection
- O-rings on all sides mounted in corrosion-proof material
- Friction washers guarantee smooth spindle guiding
- Suitable for underground installation
- Duplex stainless steel spindle

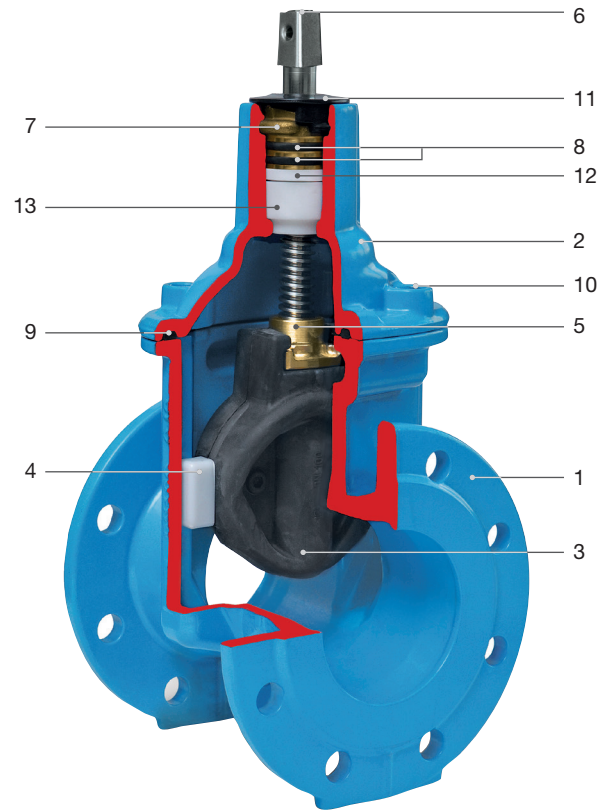

Material | Technical features

- 1,2 Body (1), bonnet (2) made of ductile iron, epoxy powder coated inside and out (see page 4)
- 3 Wedge made of ductile iron, fully rubberized with vulcanized elastomer inside and out
- 4 Wedge guide made of wear-resistant POM
- 5 Wedge nut made of brass
- 6 Duplex stainless steel spindle with rolled thread and polished O-ring slide faces, bearing made of POM
- 7 O-ring bush made of brass, attached in bonnet by bayonet connection, anti-rotation, multiple O-ring sealing
- 8 O-rings made of elastomer
- 9 Bonnet gasket made of elastomer
- 10 Allen screws corrosion protected by being encased into the body with an enclosing gasket and wax
- 11 Covering cap as dirt protection of the spindle bearing made of PE
- 12 Friction washer made of POM
- 13 Spindle bearing made of POM

Notes



Hawle-E1+ gate valve

With flange DN 50 – 300, PN 10 | PN 16



Design features

- Resilient seated gate valve with smooth, straight bore
- Flanges sized in accordance with EN 1092-2, drilled according to EN 1092-2 | PN 10 standard; EN 1092-2 | PN 16 for DN 200 Please specify on order - other standards on request
- Suitable for cleaning with a cleaning pig
- Short face-to-face length (EN 558 GR 14)
- Long face-to-face length (EN 558 GR 15)

No. 4000E1+
No. 4700E1+

Standard version: without handwheel and extension spindle (only suitable for manual actuation)

Special versions: on request

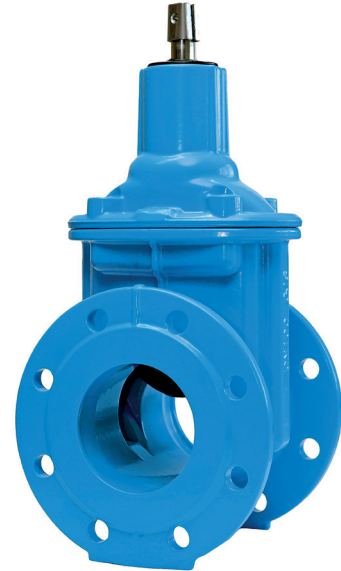

Suitable accessories

Suitable accessories: see page A 2/2

Handwheel:		No. 7800
Extension spindles:	rigid	No. 9000
	from DN 65	No. 9000A
	telescopic	No. 9500
	from DN 65	No. 9500A
Surface boxes:		No. 9500
	rigid	No. 1750
	telescopic	No. 2050
		No. 2051K
Base plate:		No. 3480, No. 3481
Operating cap:		No. 2156, No. 2157, No. 2158
Spindle extension:		No. 7820, No. 7825
Bolts:		No. 8810, No. 8830, No. 8840
HAWAK-pillar:		No. 9894
Flat gasket:		No. 3390, No. 3470

Application example



Order no.	Version	MOP (PN)	Dimensions/DN								
			50	65	80	100	125	150	200	250	300
4000E1+	short EN 558-1 GR 14	10									
		16									
4700E1+	long EN 558-1 GR 15	10									
		16									

Hawle-E1+ gate valve

With flange DN 50 – 300, PN 10 | PN 16

No. 4000E1+

No. 4700E1+

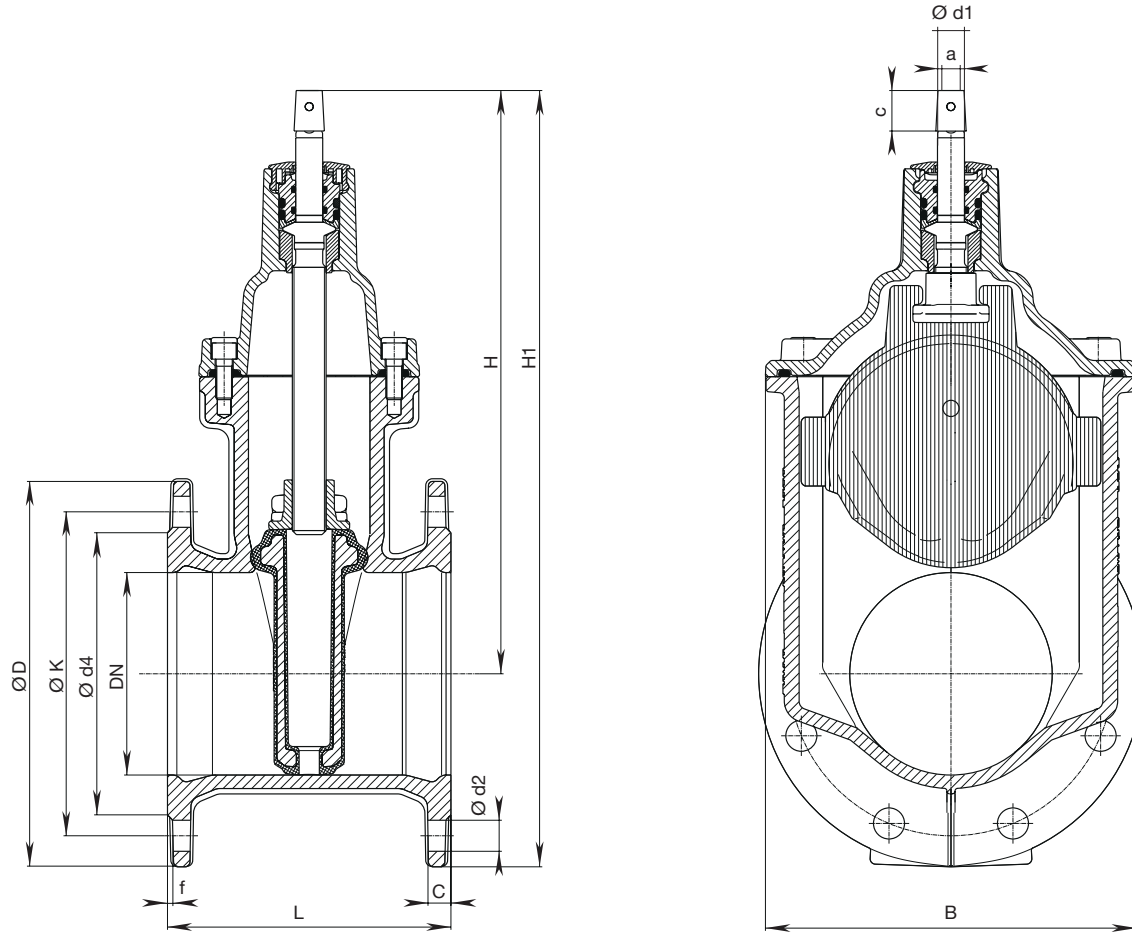

DN	MOP (PN)	Flange					Bolts			Spindle			Valve				Weight		
		ØD	C	ØK	Ød4	f	Qty	Thread	Ød2	a	c	Ød1	H	H1	L		B	short	long
50	10	165	18	125	98	5	4	M 16	19	14,8	30	18	230	313	150	250	135	8,8	10,7
	16																		
65	10	185	18	145	118	5	4	M 16	19	17,3	30	20	298	390	170	270	172	13,5	16,9
	16																		
80	10	200	18	160	133	5	8	M 16	19	17,3	30	20	305	405	180	280	172	14,5	19,0
	16																		
100	10	220	18	180	153	5	8	M 16	19	19,3	30	20	339	449	190	300	203	18,5	25,2
	16																		
125	10	250	17	210	183	4	8	M 16	19	19,3	30	20	420	545	200	325	275	30,5	36,7
	16																		
150	10	285	17	240	209	4	8	M 20	23	19,3	30	20	432	575	210	350	275	34,0	42,9
	16																		
200	10	340	19,5	295	264	4,5	8	M 20	23	24,3	38	25	534	704	230	400	345	54,6	68,0
	16																		
250	10	400	21,5	350	318	4,5	12	M 20	23	27,3	38	32	626	826	250	450	422	80,5	82,0
	16																		
300	10	455	24	400	371	5,5	12	M 20	23	27,3	38	32	709	937	270	500	506	125,0	142,4
	16																		

E2 Gate Valve

Overview



Design features

- Resilient seated gate valve according to EN 1171, EN 1074-1 and EN 1074-2 with smooth straight-through bore
- Flange valve
- Wedge guide with high glide characteristics; load-optimised design guarantees lowest wear and minimum closing torques
- Wedge nut allows high torque load through large dimensioning of the required thread length
- O-rings, lip seals mounted in rust-proof material on all sides, can be replaced in depressurised state
- Edge protection protects during transport and storage
- Roller bearings guarantee low friction mounting of the spindle
- 100% suitable for underground installation

DN 450 – 600 Spindle bearing on ball bearing

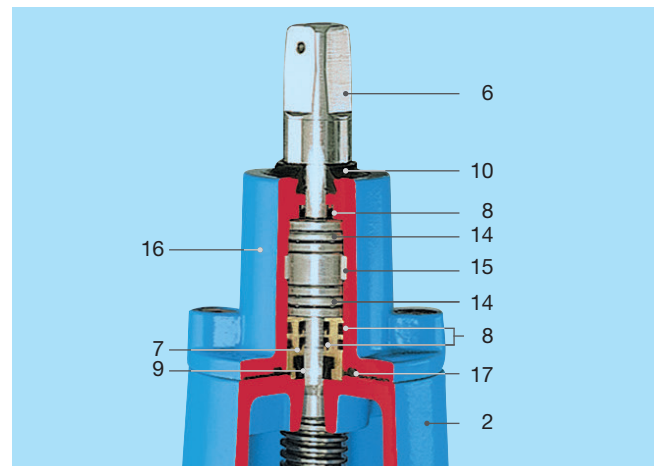

Material | Technical features

- 1, 2, Body (1), bonnet (2), centering flange (16)
- 16 made of ductile iron, epoxy powder coated inside and out (see page 5)
- 3 Wedge made of ductile iron, inside and out with vulcanized elastomer
- 4 Wedge guide made of wear-resistant plastic
- 5 Wedge nut made of dezincification-resistant brass
- 6 Duplex stainless steel spindle with rolled thread and flat-rolled sealed sliding surface
- 7 O-ring bush made of brass
- 8 O-rings, lip seals made of elastomer
- 9 Back seal made of elastomer
- 10 Wiper ring made of elastomer
- 11 Bonnet gasket made of elastomer
- 12 Allen screws encased into the body with an enclosing gasket and wax, ensuring full corrosion protection
- 13 Edge protection made of PE
- 14 Ball bearing permanently lubricated
- 15 Centering ring made of POM
- 17 Centering flange gasket made of elastomer

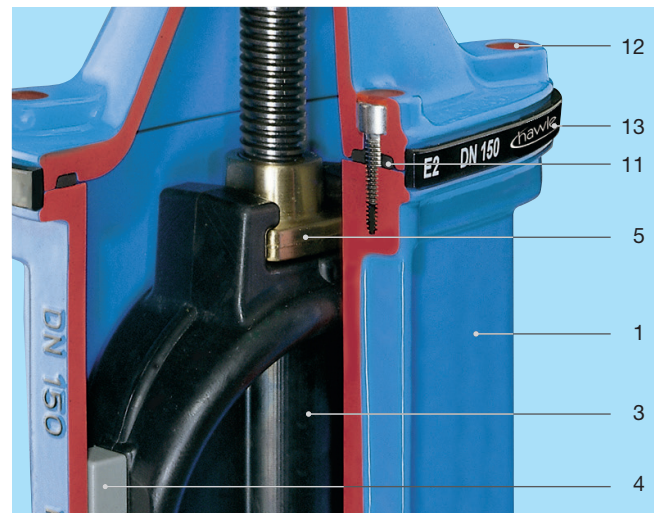

E2 Gate valve

With flange DN 450 – 600, PN 10 | PN 16

Accessories

Handwheels	Page M 4/1
Extension spindles	Page M 2/1
Surface boxes	Page M 3/1
Base plate	Page M 3/7
Adapter and coupling socket	Page M 4/3
Operating cap	Page M 4/1
Spindle extension	Page M 4/1
Actuator	Page M 4/3
Position indicator	Page M 4/2
Bolts	Page M 4/4
HAWAK-pillar	Page M 5/1
Flat gaskets	Page M 7/1
Blanking cap	Page M 4/1
Flanges	Page C 4/1
Dismantling pieces	Page D 6/1

Spare parts

Valve bonnet	Page P 2/1
Valve wedge	Page P 2/1
Valve bonnet flat gasket	Page P 2/2

Tools

Operating key	Page Q 4/2
---------------	------------

Technical information

Tightening torques for flange assembly	Page R 3/1
Pressure loss diagram	Page R 4/1
Spindle rotations per stroke	Page R 1/2

Application examples



E2 Gate valve

With flange DN 450 – 600, PN 10 | PN 16



Design features

- Resilient seated gate valve with smooth straight-through bore
 - Flanges sized in accordance with EN 1092-2, drilled according to
EN 1092-2 | PN 10 standard 4000E2, 4700E2;
EN 1092-2 | PN 16 4000E2, 4700E2
- Please specify on order - other standards on request
- Suitable for cleaning with a cleaning pig
 - Suitable for operation by automatic actuators
 - O-rings replaceable without pressure
 - Ball bearings in the spindle seating minimizes closing forces
 - Easy to actuate without bypass and without power boost - even for 16 bar differential pressure
 - For the assembling of a position indicator it is necessary to remove the centering flange and mount the adapter for position indicator

No. 4000E2
No. 4700E2



Standard version: without handwheel and extension spindle

Design versions: for actuator: No. 4000ELE2
with position indicator: No. 4000STE2
for seawater: No. 4002E2,
No. 4702E2

Special versions: on request
- Bevel gearing
- for DN 500/DN 600 - version with bypass (DN 50) available
- Ventilation and exhausting;
small amounts of air in the bonnet

Order no.	Version	MOP (PN)	Dimensions/DN			
			450*	500*	500	600
4000E2	short	16				
	EN 558 GR 14					
4700E2	long	16				
	EN 558 GR 15					

* Body: DN 400 - flange connection: DN 450 or 500

Suitable accessories: see page A 11/2

Handwheel: No. 7800
Extension spindles: rigid No. 9000E2
telescopic No. 9500E2
Surface boxes: rigid No. 1750
telescopic No. 2050
No. 2051K
Valve actuator: No. 9920
Adapter for actuator (E2 adapter): No. 8630E2
Base plate: No. 3481, No. 3482
Operating cap: No. 2156, No. 2157, No. 2158
Extension spindle: No. 7820, No. 7825
Bolts: No. 8810, No. 8830, No. 8840
HAWAK-pillar: No. 9894, No. 9895
Flat gasket: No. 3390, No. 3470

E2 Gate valve

With flange DN 450 – 600, PN 10 | PN 16

No. 4000E2

No. 4700E2

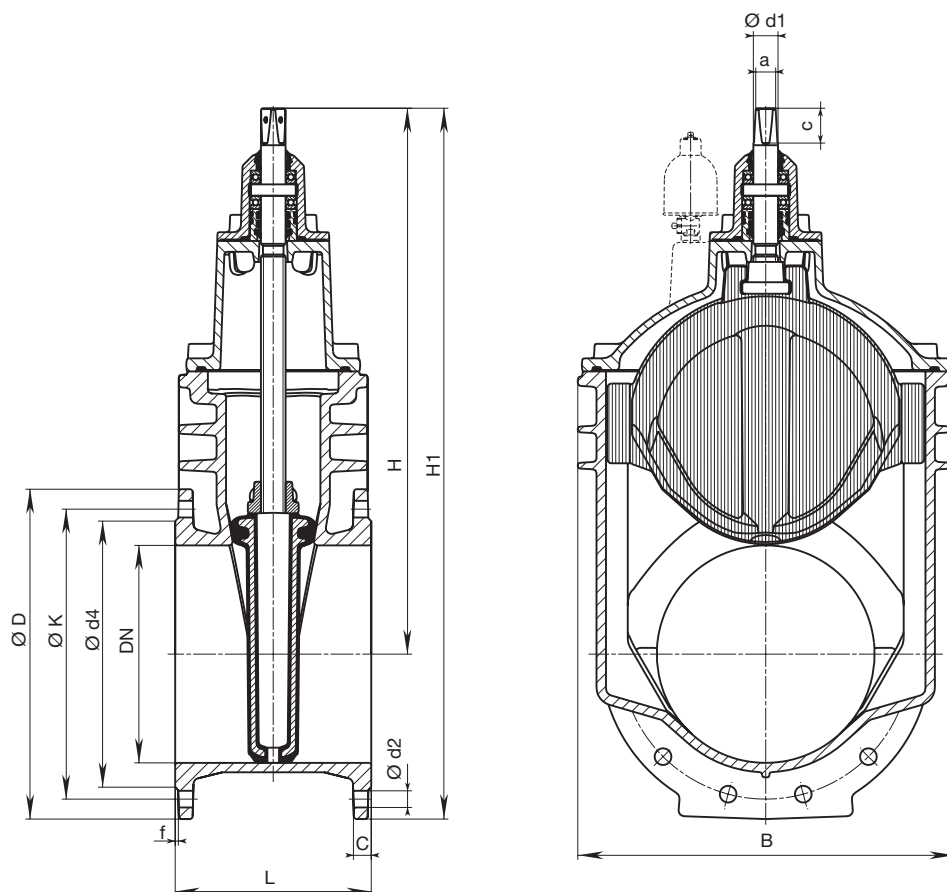

DN	MOP (PN)	Flange					Bolts			Spindle			Valve				Weight		
		Ø D	C	Ø K	Ø d4	f	Qty.	Thread	Ø d2	a	c	Ø d1	H	H1	L short	L long	B	short	long
450*	10	640	30	565	530	4	20	M 24	28	32,3	55	44	974	1310		650	687		332,0
				585				M 27	31										
500*	10	715	31,5	620	582	4	20	M 24	28	32,3	55	44	974	1345		700	687		371,0
				650				M 30	34										
500	10	715	31,5	620	582	4	20	M 24	28	36,3	66	50	1220	1578	350	700	800	488,0	542,0
				650				M 30	34										
600	10	840	36	725	720	5	20	M 27	31	36,3	66	50	1377	1797	390	800	944	720,0	789,0
				770				M 33	37										

* Body: DN 400 - flange connection: DN 450 or 500



<p>Page D 2</p>	<p>Fittings Double flanged piece Double flanged taper, double flanged elbows 45° Double flanged elbows 90°, all flanged short tee All flanged tee</p>	<p>Page D 2/1 Page D 2/2 Page D 2/3 Page D 2/4</p>	
<p>Page D 3</p>	<p>Fittings All flanged crosses, all flanged short cross Double flanged duck foot bends 90° <i>Fittings SYSTEM 2000</i> <i>SYNOFLEX end cap, flanged duck foot bends</i></p>	<p>Page D 3/1 Page D 3/2 Page F 4/2 Page E 4/2</p>	
<p>Page D 4</p>	<p>Fittings Wafer tee piece, space ring, angle piece adjustable Flap valve</p>	<p>Page D 4/1 Page D 4/2</p>	
<p>Page D 5</p>	<p>Hawle Vario Hawle-Vario - the innovative flexible fitting</p>	<p>Page D 5/1</p>	
<p>Page D 6</p>	<p>Dismantling piece PN 10 PN 16 PN 25</p>	<p>Page D 6/1</p>	

Fittings

Accessories

Bolts
Flat gaskets

Page M 4/4
Page M 7/1

Technical information

Tightening torques for flange assembly Page R 3/1

Application examples



Design features

- According to EN 545
- Working pressure MOP (PN) 16
- Made of ductile iron, epoxy powder coated
- Flange size according to EN 1092-2 | PN 16
- Standard drilling to EN 1092-2 | PN 10

DN	L	Weight
50	200	6,5
	400	10,0
65	200	8,0
	400	13,0
80	100	7,6
	150	8,5
	200	9,2
	300	10,8
	400	12,4
	500	14,1
	600	15,7
	800	19,0
100	1000	22,0
	100	8,6
	150	9,8
	200	10,7
	300	12,7
	400	14,8
	600	18,8
125	800	23,0
	1000	27,0
	200	13,3
	600	24,0
150	1000	34,5
	150	20,0
	200	16,5
	300	19,7
	400	23,0
	600	29,5
200*	800	36,0
	1000	42,5
	200	20,0
	600	41,5
250	800	50,5
	1000	60,0
	200	22,1
	300	38,0
	400*	44,0
	500*	50,5
300	600	56,3
	800	68,5
	1000	81,0
	300	49,5
	400*	57,0
300	500	65,0
	600	73,0
	800	88,5
	1000	104,0

Double flanged pipe

FF-piece
No. 8500

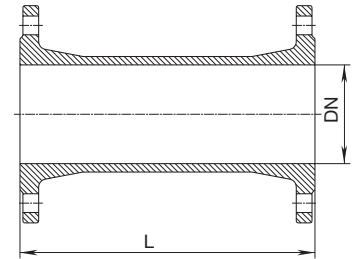

* Also available drilled to EN 1092-2 | PN 16
(Please specify on order)

Fittings

Design features

- According to EN 545
- Working pressure MOP (PN) 16
- Made of ductile iron, epoxy powder coated
- Flange size according to EN 1092-2 | PN 16
- Standard drilling to EN 1092-2 | PN 10

DN	DN 1	L	Weight
65	50	200	9,0
80	50	200	7,4
	65	200	8,2
100	50	200	8,1
	65	200	8,8
	80	200	9,5
125	65	200	19,0
	80	200	10,7
	100	200	11,4
150	80	200	12,2
	100	200	16,7
	125	200	14,1
200*	100	300	18,6
	125	300	20,0
	150	300	22,0
250	100	300	22,0
	150	300	27,0
	200*	300	30,5
250+	125	300	41,0
	100	300	35,0
300	150*	300	37,0
	200*	300	35,5
	250*	300	41,0
350	300	300	64,0
400	350*	300	81,0
500	300	600	110,0
	400	600	129,0

Design features

- According to EN 545
- Working pressure MOP (PN) 16
- Made of ductile iron, epoxy powder coated
- Flange size according to EN 1092-2 | PN 16
- Standard drilling to EN 1092-2 | PN 10

DN	b	Weight
50	150	9,0
65	165	12,0
80	130	9,5
100	140	11,5
125	150	14,6
150	160	18,7
200*	180	27,5
250	350	80,0
300	400	112,0

Double flanged taper

FFR piece
No. 8550

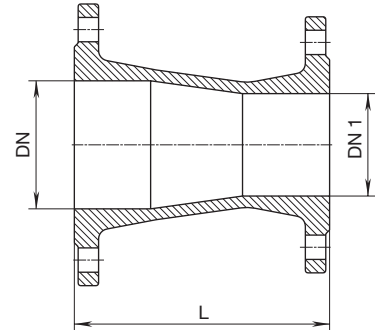
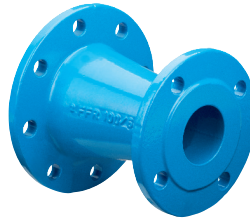

* Also available drilled to EN 1092-2 | PN 16
(Please specify on order)

* Only PN 16 available

Double flanged elbows 45°

45° FFK piece
No. 8540

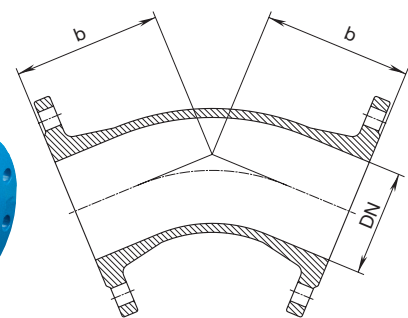

* Also available drilled to EN 1092-2 | PN 16
(Please specify on order)

Fittings



Design features

- According to EN 545
- Working pressure MOP (PN) 16
- Made of ductile iron, epoxy powder coated
- Flange size according to EN 1092-2 | PN 16
- Standard drilling to EN 1092-2 | PN 10

DN	b	Weight	
50	150	9,3	
65	165	9,7	
80	165	10,5	
100	180	12,9	
125	200	16,5	
150	220	20,5	
200*	260	31,0	
250*	350	50,0	
300	400	70,0	

Double flanged elbows 90°

90° Q piece

No. 8530

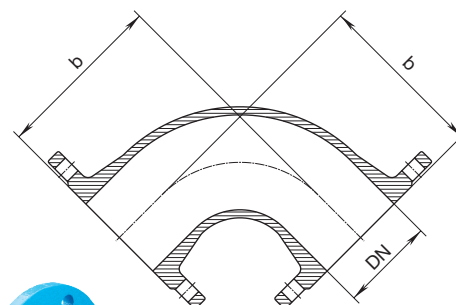
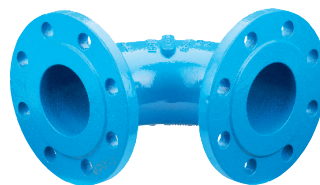

* Also available drilled to EN 1092-2 | PN 16
(Please specify on order)

Design features

- Working pressure MOP (PN) 16
- Made of ductile iron, epoxy powder coated
- Flange size according to EN 1092-2 | PN 16
- Standard drilling to EN 1092-2 | PN 10
- On request: No. 8741 with vertical outlet DN 100 (surcharge)

DN	L	H	Weight	
200*	400	200	47,0	
250*	460	230	66,0	
300*	520	260	86,0	

All flanged short tee

No. 8740

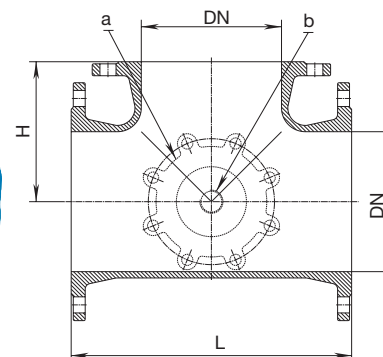
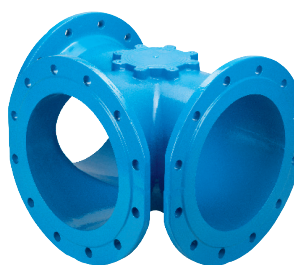

* Also available drilled to EN 1092-2 | PN 16
(Please specify on order)

Fittings

Design features

- According to EN 545
- Working pressure MOP (PN) 16
- Made of ductile iron, epoxy powder coated
- Flange size according to EN 1092-2 | PN 16
- Standard drilling to EN 1092-2 | PN 10

DN	DN 1	L	H	Weight
50	50	300	150	12,5
65	50	330	157	15,5
	65		165	16,5
80	50	330	160	14,0
	65		165	14,7
	80		165	16,0
100	50	360	170	17,6
	65		170	17,4
	80		175	18,6
	100		180	19,4
125	50	400	185	30,0
	65		195	31,0
	80		190	23,0
	100		195	24,0
	125		200	25,5
150	50	440	200	39,0
	65		207	39,0
	80		205	29,0
	100		210	30,0
	125		215	31,0
	150		220	33,8
200*	80	520	235	42,5
	100		240	43,0
	125		245	44,0
	150		250	46,5
	200		260	50,0
250	80*	700	270	71,0
	100*		275	75,0
	125		280	93,0
	150*		300	81,0
	200*		325	76,5
	250*		350	83,0
300	80*	800	290	92,0
	100		300	94,0
	150*		325	101,0
	200		350	102,0
	300*		400	114,0
300+	250	800	400	120,0
400	200	900	350	162,0
	250		350	170,0
500	150*	1000	400	245,0
	500		500	278,0

All flanged tee

T-piece

No. 8510

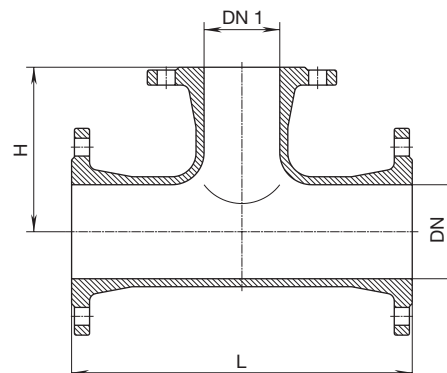
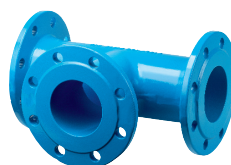

* Also available drilled to EN 1092-2 | PN 16
(Please specify on order)

* Only PN 16 available

Design features

- Working pressure MOP (PN) 16
- Made of ductile iron, epoxy powder coated
- Flange size according to EN 1092-2 | PN 16
- Standard drilling to EN 1092-2 | PN 10

DN	L	Weight	
80	330	27,0	
100	360	34,0	
150	440	46,0	
200*	520	59,7	
250*	700	135,0	
300*	800	186,0	

* Also available drilled to EN 1092-2 | PN 16
(Please specify on order)

All flanged crosses

TT-piece
No. 8520

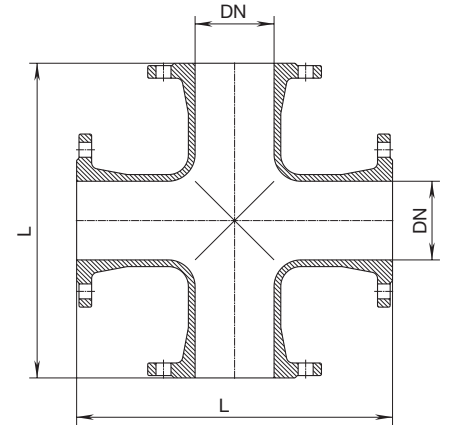
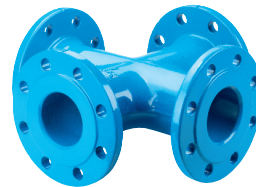

Design features

- Working pressure MOP (PN) 16
- Made of ductile iron, epoxy powder coated
- Flange size according to EN 1092-2 | PN 16
- Standard drilling to EN 1092-2 | PN 10
- On request: No. 8751 with vertical connection DN 100 (additional price)

DN	L	Weight	
200*	400	60,0	
250*	460	91,0	
500	830	333,0	

All flanged short cross

TT-piece
No. 8750

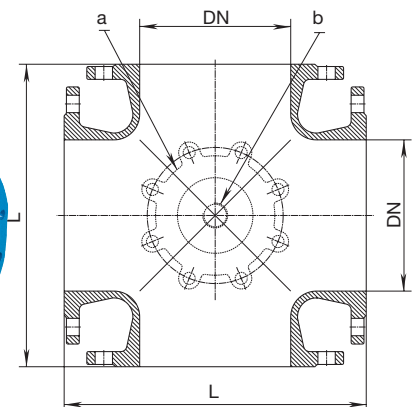

* Also available drilled to EN 1092-2 | PN 16
(Please specify on order)

Fittings

Design features

- According to EN 545
- Working pressure MOP (PN) 16
- Made of ductile iron, epoxy powder coated
- Flange size according to EN 1092-2 | PN 16
- Standard drilling to EN 1092-2 | PN 10

DN	b	c	Weight
50	150	95	8,4
80	165	110	13,4
100	180	125	16,8
150	220	160	29,5
200	260	190	46,0

Double flanged duck foot bend 90°

N-pieces

No. 5049

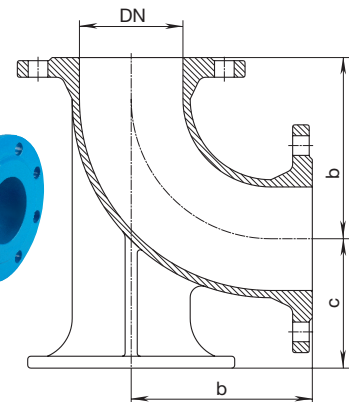

No. 5044

DN 80 and DN 100 also available with loose flange No. 5044

Design features

- Working pressure MOP (PN) 16
- Made of ductile iron, epoxy powder coated
- Flange size according to EN 1092-2 | PN 16
- Standard drilling to EN 1092-2 | PN 10

DN	b	Length (b1)	c	Weight
80	165	365	110	17,8

Double flanged duck foot bend long

N-pieces

No. 5049L

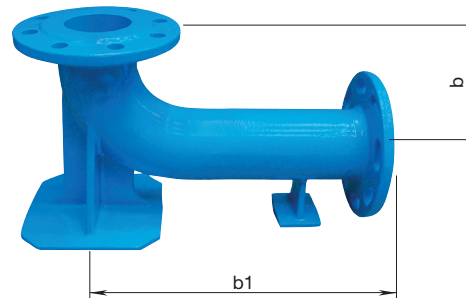

Design features

- Working pressure MOP (PN) 16
- Made of ductile iron, epoxy powder coated
- Flange size according to EN 1092-2 | PN 16
- Standard drilling to EN 1092-2 | PN 10

DN	a	b	c	d	Weight
80	260	165	110	90	16,5
100	280	180	125	110	19,5

Flanged duck foot bend with PVC socket 90°

EN-KS-pieces

No. 5046

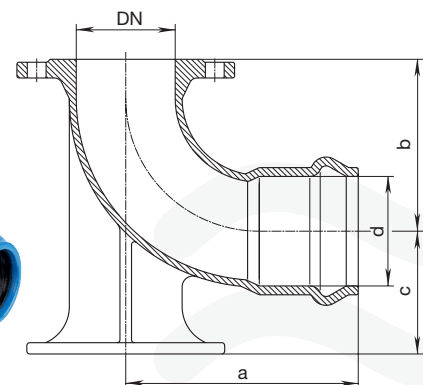

Order No.	DN	Thread	Length	Weight
8580	80	1 1/4"	60	3,8
	100		60	4,9
	150		60	8,0



Wafer tee piece No. 8580

- With one threaded outlet ISO 228
- MOP (PN) 16, made of grey ductile iron, epoxy powder coated

Order No.	DN	Thread	Length	Weight
8590	100	1 1/4"	60	4,36
	125		60	6,3
	150		60	7,8
	250		60	19,2



Wafer tee piece No. 8590

- With two threaded outlets ISO 228
- MOP (PN) 16, made of grey ductile iron, epoxy powder coated

Order No.	DN	Thread	Length	Weight
8591	100	ZAK 46	70	3,35
	150		70	5,28
	200		70	6,75
	250		70	9,9
	300		70	12,0
	400		70	16,6



Wafer tee piece ZAK No. 8591

- With two ZAK 46 outlets
- MOP (PN) 16, made of ductile iron, epoxy powder coated

Order No.	DN
8615	50
	65
	80
	100
	125
	150
200	



Spacer ring No. 8615

- For length equalisation between flanges
- Steel, epoxy powder coated
- Give face-to-face length "L" on order

Order No.	DN	Weight
8730	50	1,5
	65	1,7
	80	0,35
	100	2,0
	125	0,5
	150	0,6
	200	0,9
	250	1,26
300	1,8	



Angle piece adjustable 0° – 8° No. 8730

- Made of steel with vulcanised elastomer
- No flat gasket needed

DN	MOP (PN)	Width	
		Min.	Max.
50	10 – 40	11	22
65		11	25
80		11	30
100	10 – 16	11	32
125		11	35
150		11	39
200		12	46
250	10	12	52
300		14	55

Fittings

Flap valve, PN 10 | PN 16

Design features

- Flange connection according to EN 1092-2, drilled according to EN 1092-2 | PN 10 standard; EN 1092-2 | PN 16 DN 200 – DN 600 please specify on order
- Double hinged for improved sealing performance
- Gasket on the cover for noise reduction and durability of the coating

Material | Technical features

- **Body and cover** made of ductile iron, epoxy powder coated
- **All connections** made of stainless steel
- **Seal** made of elastomer
- **External joint** prevents any obstruction thanks to the free outflow

No. 9930

DN 50 – 150

DN 200 – 600

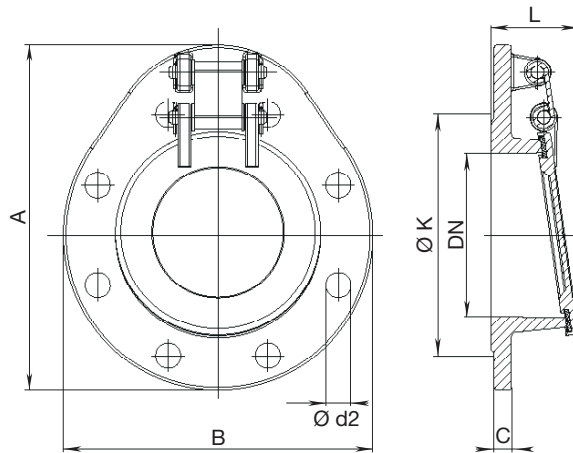

Ill.: symbol

DN	MOP (PN)	A	B	L	ØK	C	Bolts		Weight
							Qty	Ød2	
50	10/16	177,5	165	56	125	19	8	19	3,05
65		197,5	185	56	145	19	8	19	3,67
80		245,0	200	68	160	19	8	19	5,17
100		267,5	220	73	180	19	8	19	5,88
125		295,0	250	78	210	19	8	19	7,81
150		317,5	285	80	240	19,0	8	23	9,2
200	10	406	340	130	295	20,0	8	23	23,0
	16				12		23		
250	10	462	405	138	350	22,0	12	23	30,0
	16				12		28		
300	10	518	455	142	400	24,5	12	23	37,0
	16				12		28		
400	10	658	580	177	515	24,5	16	28	68,0
	16				16		31		
500	10	793	715	207	620	26,5	20	28	112,0
	16				20		34		
600	10	918	840	217	725	30,0	20	31	160,0
	16				20		37		

Larger dimensions on request

Hawle-Vario

The innovative flexible fitting, PN 10 | PN 16



Design features

- Hawle Vario is a flanged, telescopic fitting with integrated ball-and socket joint, permitting bending to all sides up to an angular deflection of 10 degrees
- Flange size according to EN 1092-2 | PN 16, drilled according to EN 1092-2 | PN 10 standard; EN 1092-2 | PN 16 DN 200 please specify on order - other standards on request
- Hawle Vario will be fixed in the installed position by means of a tension lock assembly
- Combines the function of an FF-piece, an adjustable elbow piece and a fitting and extension piece
- HHawle Vario saves time and has numerous application possibilities

No. 8010S

No. 8011S

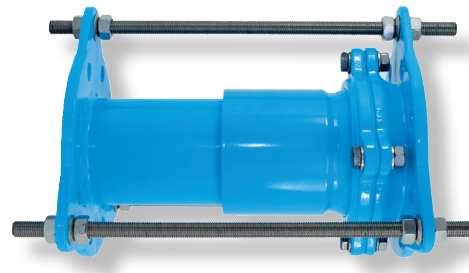
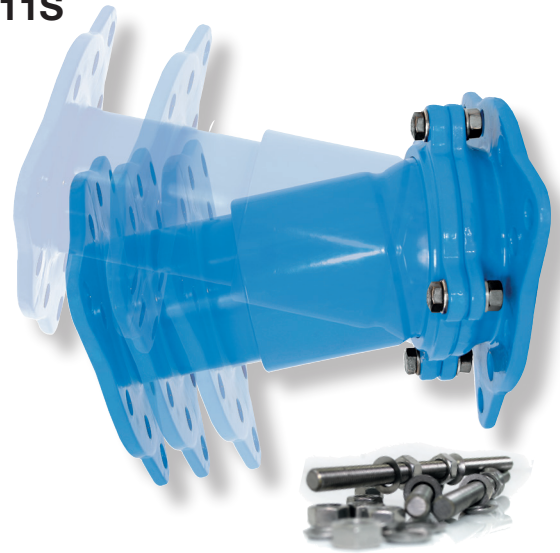

Material | Technical features

- **Body** made of ductile iron, epoxy powder coated
- **Locking ring, bolts, nuts and washers** made of stainless steel
- **Tension lock** made of stainless steel
- **O-rings** made of elastomer

Order No.	Set-version	MOP (PN)	Dimensions/DN				
			50	80	100	150	200
8010S	short	16					
8011S	long						

Application example



Hawle-Vario

The innovative flexible fitting, PN 10 | PN 16

No. 8010S Short version, with tension lock

No. 8011S Long version, with tension lock

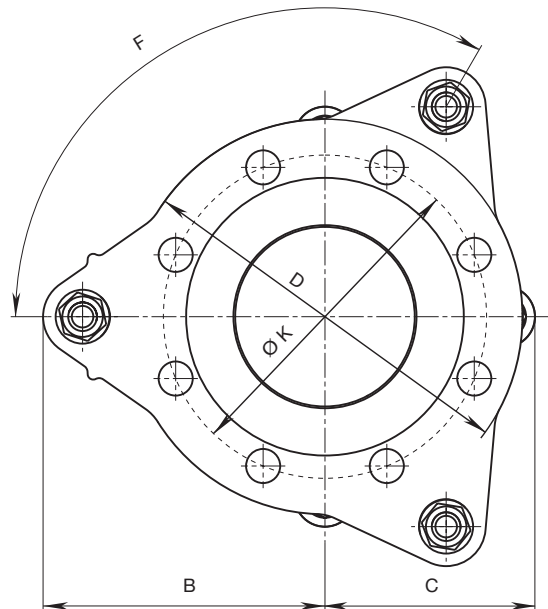
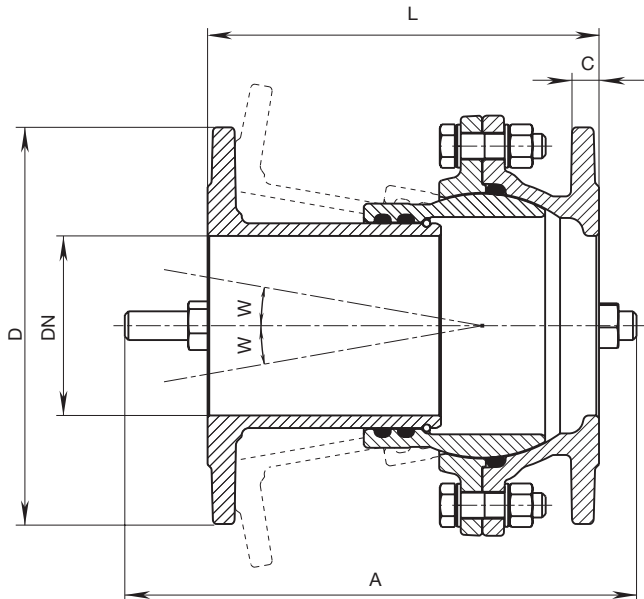

DN	MOP (PN)	Version	Adjustment range L	A	B	C	D	F	C	ØK	Angle W	Weight
50		short	150 – 207	285	130	87	165	3 x 120°	16	125	0 – 10°	8,9
		long	207 – 323	415								11,8
80		short	150 – 214	285	147	107	200	3 x 120°	16	160	0 – 10°	14,3
		long	214 – 344	415								16,85
100		short	150 – 216	285	157	117	220	3 x 120°	16	180	0 – 10°	16,2
		long	216 – 350	415								18,9
150		short	175 – 250	330	190	190	285	4 x 90°	18	240	0 – 10°	27,0
		long	250 – 408	480								29,3
200	10/16	short	195 – 290	360	229	229	340	4 x 90°	20	297	0 – 8°	44,8
		long	282 – 450	530								52,2



Dismantling piece

PN 10 | PN 16 | PN 25



Design features

- Double flanged fitting, which allows longitudinal adjustment in flanged pipe systems
- Easy assembly and disassembly of flanged connections
- Continuous threaded bars, therefore, no additional mounting screws necessary
- Length adjustment range: (see table) +/- 25 mm
- Flange in accordance with and drilled to EN 1092-2 | PN 10, PN 16, PN 25 (PN 40 on request)

Material | Technical features

- 1,2 **Flanges** made of ductile iron, epoxy powder coated
+ made of steel, epoxy powder coated
- 3 **Retaining flange** made of steel, epoxy powder coated
- 4 **Sealing ring** made of elastomer
- 5 **Threaded bar** made of galvanized steel
- 6 **Bolts** made of galvanized steel

Pressure rating PN 10

DN	MOP (PN)	L	L1	ØD	ØK	C	Bolts Qty.	Ø d2	Weight
50*	10	180	280	165	125	19,0	4	19	11,0
65*		180	280	185	145	19,0	4	19	13,0
80		200	330	200	160	19,0	8	19	17,0
100		200	330	220	180	19,0	8	19	20,0
125		200	330	250	210	19,0	8	19	24,0
150		200	330	285	240	19,0	8	23	30,0
200		200	330	340	295	20,0	8	23	42,0
250		220	360	405	350	22,0	12	23	62,0
300		220	360	460	400	24,5	12	23	67,0
350		230	360	505	460	24,5	16	23	85,0
400		230	370	565	515	24,5	16	28	105,0
450		250	390	615	565	25,5	20	28	131,0
500		260	390	670	620	26,5	20	28	155,0
600		260	410	780	725	30,0	20	31	225,0
700		260	410	895	840	32,5	24	31	300,0
800		290	460	1015	950	35,0	24	34	361,0
900		290	460	1115	1050	37,5	28	34	400,0
1000	290	500	1230	1160	40,0	28	37	516,0	
1100	300	480	1355	1270	53,5	32	37	830,0	
1200	320	520	1455	1380	45,0	32	41	895,0	
1300	370	630	1585	1490	59,0	32	42	1172,0	
1400	360	560	1675	1590	46,0	36	44	1194,0	
1500	380	590	1785	1700	47,0	36	44	1560,0	
1600	390	600	1915	1820	49,0	40	50	1436,0	

Dismantling piece No. 9810



Order No.	MOP (PN)	Dimensions/DN																									
		50	65	80	100	125	150	200	250	300	350	400	450	500	600	700	800	900	1000	1100	1200	1300	1400	1500	1600*		
9810	10																										
	16																										
	25																										

*Larger dimensions or pressure rating of PN 40 on request

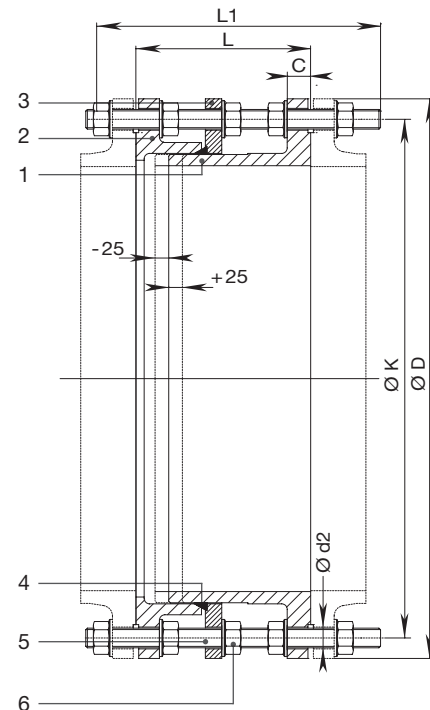

Dismantling piece

PN 10 | PN 16 | PN 25

No. 9810

Pressure rating PN 16

DN	MOP (PN)	L	L1	ØD	ØK	C	Bolts		Weight
							Qty.	Ø d2	
50	16	180	280	165	125	19,0	4	19	11,0
65		180	280	185	145	19,0	4	19	13,0
80		200	330	200	160	19,0	8	19	17,0
100		200	330	220	180	19,0	8	19	20,0
125		200	330	250	210	19,0	8	19	24,0
150		200	330	285	240	19,0	8	23	30,0
200		200	330	340	295	20,0	12	23	45,0
250		230	370	405	355	22,0	12	28	66,0
300		250	410	460	410	24,5	12	28	84,0
350		260	410	520	470	26,5	16	28	107,0
400		270	430	580	525	28,0	16	31	142,0
450		270	430	640	585	30,0	20	31	177,0
500		280	440	715	650	31,5	20	34	200,0
600		300	500	840	770	36,0	20	37	305,0
700		300	500	910	840	39,5	24	37	321,0
800		320	520	1025	950	43,0	24	41	469,0
900	320	520	1125	1050	46,5	28	41	535,0	
1000	340	560	1255	1170	50,0	28	44	698,0	
1100	340	560	1355	1270	53,5	32	44	830,0	
1200	360	600	1485	1390	57,0	32	50	1070,0	
1300	370	630	1585	1490	59,0	32	50	1172,0	
1400	380	630	1685	1590	60,0	36	50	1270,0	
1500	380	610	1820	1710	62,5	36	57	1560,0	
1600	400	700	1930	1820	65,0	40	57	1705,0	

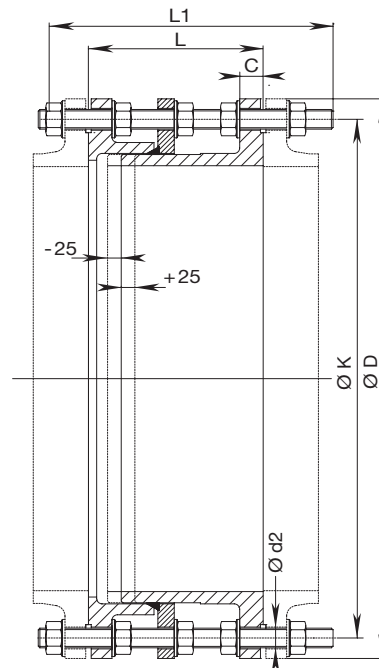

No. 9810

Pressure rating PN 25

DN	MOP (PN)	L	L1	ØD	ØK	C	Bolts		Weight
							Qty.	Ø d2	
100	25	220	340	235	190	19,0	8	23	32,0
125		220	370	270	220	19,0	8	28	43,0
150		230	370	300	250	20,0	8	28	52,0
200		230	370	360	310	22,0	12	28	76,0
250		250	410	425	370	24,5	12	31	108,0
300		250	410	485	430	27,5	16	31	129,0
350		270	480	555	490	30,0	16	34	196,0
400		280	500	620	550	32,0	16	37	212,0
450		280	480	670	600	34,5	20	37	281,0
500		300	500	730	660	36,5	20	37	290,0
600		320	520	845	770	42,0	20	41	389,0
700		340	530	960	875	46,5	24	44	505,0
800	360	600	1085	990	51,0	24	50	690,0	
900	380	600	1185	1090	55,5	28	50	920,0	
1000	400	650	1320	1210	60,0	28	57	1257,0	
1200	450	720	1530	1420	69,0	32	57	1870,0	



Automatic air valves

For potable water



Page
N 2

Air release valve
DN 1" and DN 2", PN 6, PN 16

Page N 2/1



Page
N 3

Air release valve HaVent
PN 25

Page N 3/1



Page
N 4

Air release valve
DN 80 / DN 100, DN 150 / DN 200

Page N 4/1



Page
N 5

Combined air release valve

Page N 5/1



Page
N 6

Air release valve
Dynamic PN 10 | PN 16 | PN 25 | PN 40

Page N 6/1



Air release valves

Accessories

Flushing stand pipe
Surface box

Page N 5/1
Page M 3/3

Spare parts

Valve 1"

Seite N 2/2

Tools

Valve key 1"

Page Q 4/3

Dimensioning (recommendation)

Pipe	Valve
DN ≤ 80	DN 1"
DN 100 – 250	DN 2" (DN 50)
DN 300 – 400	DN 80
DN 450 – 500	DN 100
DN 600 – 900	DN 150
DN ≥ 1000	DN 200

Technical information

Tightening torques for flange assembly

Page R 3/1

Application examples



Air release valves

PN 6 | PN 16



Design features

- Automatic, dynamic air release valve
- PE shield for UV protection
- The internal thread inlet is reinforced with a stainless steel ring
- Connection variants: Internal thread or flange
- Insect protective grid (2" valve)
- Installation: upright, preferably at the highest point in the pipeline together with isolating valves
- Air valve for releasing air only: on request (minimum pressure of 0,3 bar needed)

Material | Technical features

- **DN 1"**
 - Max. air release capacity:** 7,8 m³/h
 - Test pressure:** Body 24 bar
 - Working pressure:** 0,1 – 6 bar
0,8 – 16 bar
 - **Body** made of POM
 - **Orifice and valve plug** made of brass
 - **Float** made of POM
 - **Seal** made of Elastomer
 - **UV-shield** made of PE
- **DN 2"** - double acting
 - Max. air release capacity:** 192 m³/h
 - Test pressure:** Body 24 bar
 - Working pressure:** 0,1 – 6 bar
1 – 16 bar
 - **Body and elbow** made of POM
 - **Valve seat** made of brass
 - **Float** made of POM
 - **Seal** made of Elastomer
 - **UV-shield** made of PE
 - **Insect protective grid** made of stainless steel

No. 9876 DN 1"



No. 9876 DN 2"



No. 9874 DN 2"

Order No.	Version	DN	Working pressure bar
9876	Standard	1"	PN 0,1 – PN 6
			PN 0,8 – PN 16
9876	Standard	2"	PN 0,1 – PN 6
			PN 1 – PN 16
9874	With flange connection DN 50 or DN 80 (ductile iron)	2"	PN 0,1 – PN 6
			PN 1 – PN 16

Automatic air valves are to be maintained according to the usage conditions

Air release valves

PN 6 | PN 16

DN	MOP (PN)	Working pressure bar	Size of the opening	Ø D	Ø D1	H	Weight
1"	6	0,1 – 6	1,77 mm ²	109	122	172	0,90
	16	0,8 – 16					

Please specify working pressure when ordering

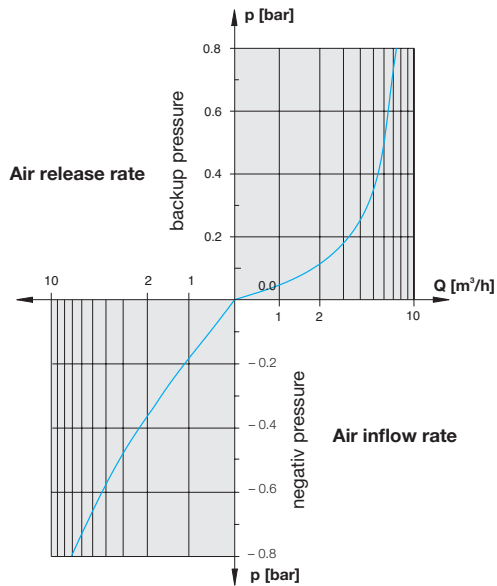

No. 9876 DN 1"

Valve (= wearing part)

No: 5016173 PN 16

No: 5016231 PN 6

Replaceable on the spot in depressurised status

- Demount safeguard ring
- Remove cap
- Loosen locking screw
- Valve with valve key unscrew No. 3454

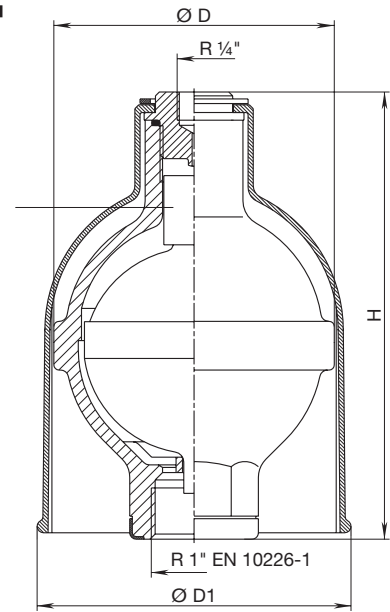

DN	MOP (PN)	Working pressure bar	Size of the opening	Ø A	Ø A1	H	H1	Weight
2"	6	0,1 – 6	900/2 mm ²	160	175	305	320	2,90
	16	1 – 16						3,40

Please specify working pressure when ordering

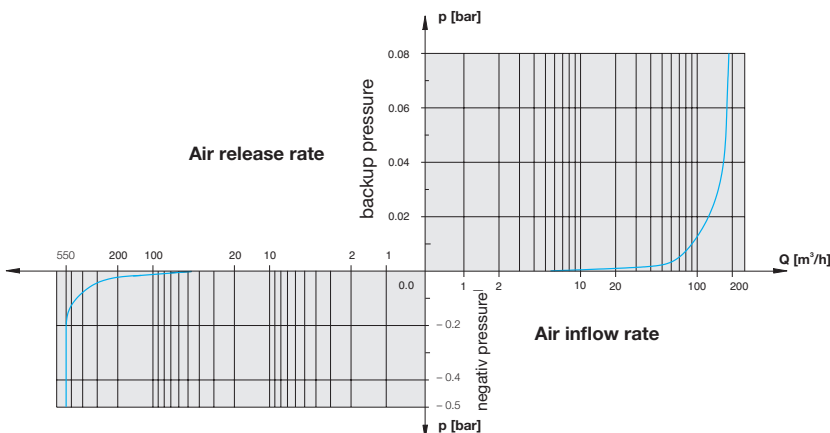

No. 9876 DN 2"

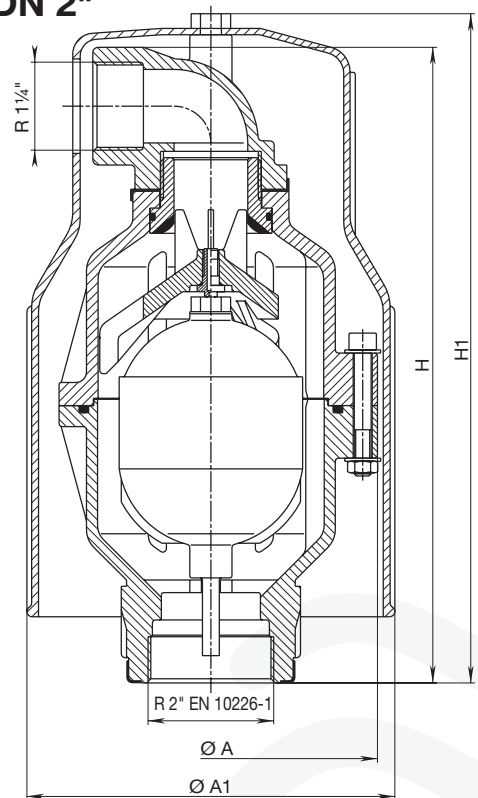

Air release valves HaVent

PN 25



Design features

- High performance air release valve with new nozzle mechanism for the optimal absorption of high pressures
- Low wear and tear due to optimum geometry
- Easy maintenance
- High-quality materials
- UV resistance
- Air release only on request
- Connecting variants: Flange DN 50, DN 80, internal thread 2"
- With insect protective grid

Material | Technical features

- **Size of the opening:** 1500 mm² / 3,15 mm²
- **Max. air release capacity:** 1150 m³/h
- **Working pressure:** 0,2 — 25 bar
- **Body** made of stainless steel
- **Float** made of foamed PP
- **Seal** made of Elastomer
- **Outlet elbow** made of PE
- **Flange** acc. EN 1092

No. 9859



Connection	H	Ø D	Weight	
IT 2"	420	160	10,00	
Flange DN 50*	455	160	12,50	
Flange DN 80*	455	160	14,50	

*on request

Air release valves HaVent

PN 25

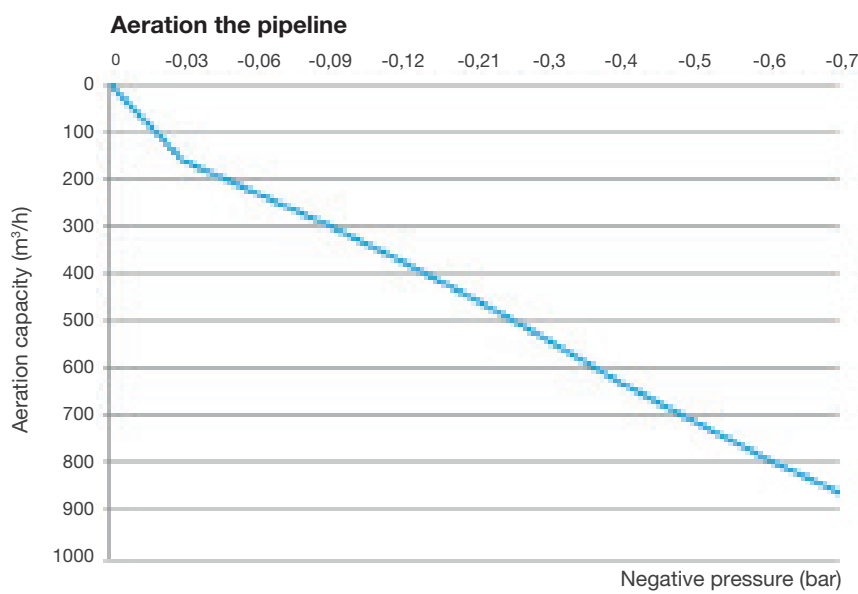
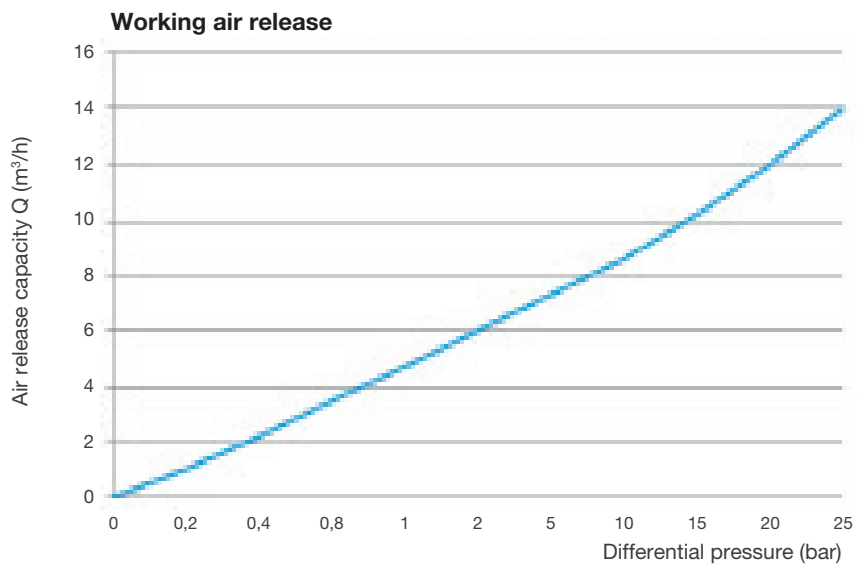
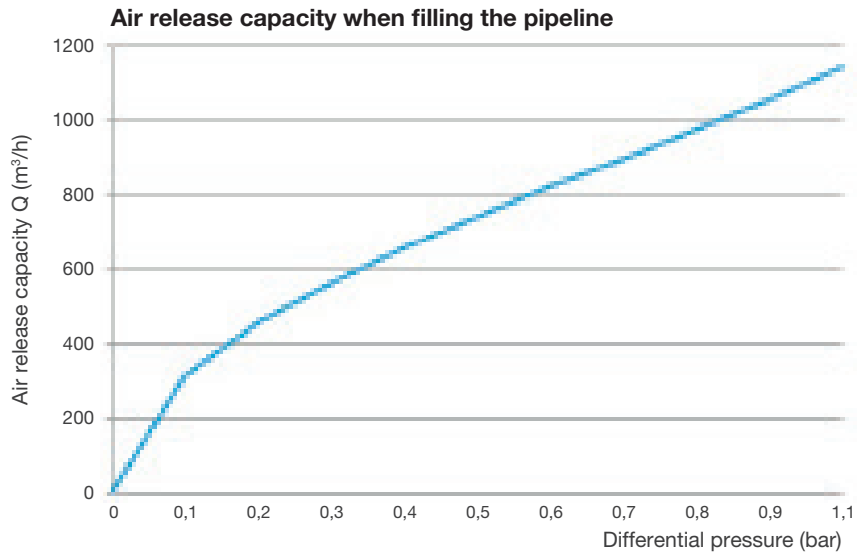

Air release valves

PN 6 | PN 16



Design features

- Automatic air release valve
- All mechanical parts made of corrosion resistant materials

Material | technical features

- **Body and bonnet** made of ductile cast iron, epoxy powder coated
- **Seat** made of stainless steel / elastomer
- **Float:** DN 80 – 100 polycarbonate
DN 150 – 200 passivated stainless steel
- **Double nipple** made of POM / stainless steel
- **Bolts and nuts** made of stainless steel

No. 9835
DN 80 / DN 100

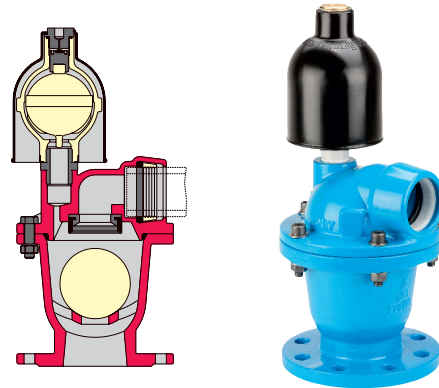

DN 150 / DN 200

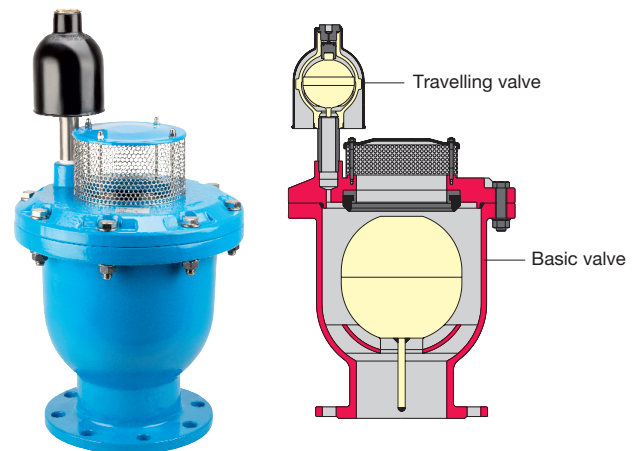

Dimensions	DN 80	DN 100	DN 150	DN 200*
Test pressure (body)	24 bar			
Working pressure PN 16 (standard)	0,8 – 16 bar			
Working pressure PN 6	0,2 – 6 bar			
Max. air release capacity	1305 m ³ /h	2450 m ³ /h	7500 m ³ /h	
Size of the opening	1810/1,77 mm ²	3320/1,77 mm ²	17670/1,77 mm ²	
PE pipe connection	d 63	d 75		
Flange drilled acc. EN 1092-2 PN 10; *DN 200 PN 16 EN 1092-2 please specify on order				

Order No.	Version	Working pressure bar	DN 80	DN 100	DN 150	DN 200
9835	Double orifice (with travelling valve)	PN 6 (0,2 – 6 bar)				
		PN 16 (0,8 – 16 bar)				
9836	Double orifice, (with travelling valve) with PE pipe & insect protective grid	PN 6 (0,2 – 6 bar)				
		PN 16 (0,8 – 16 bar)				
9837	Single orifice (without travelling valve)	PN 16 (0,2 – 16 bar)				
9838	Single orifice (without travelling valve) with PE pipe & insect protective grid	PN 16 (0,2 – 16 bar)				

Air release valves

PN 6 | PN 16

DN 80 / DN 100

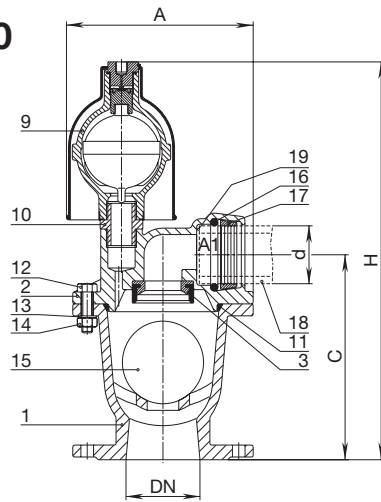

DN 150 / DN 200

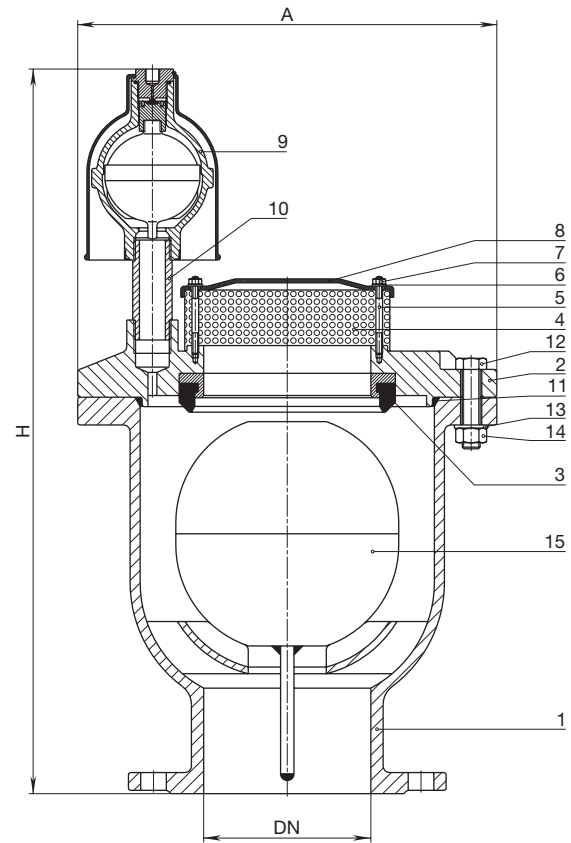

Parts	Material
1,2 Body and bonnet	Ductile cast iron, epoxy powder coated
3 Seat	Stainless steel / Elastomer
4 Grid	Stainless steel
5 Bolt	Stainless steel
6 Washer	Stainless steel
7 Nut	Stainless steel
8 Cap	Steel, epoxy powder coated
9 Automatic air valve 1"	Divers (see page N 2/1)
10 Nipple	POM (DN 80-100) / NIRO (DN 150-200)
11 O-ring	Elastomer
12 Hexagonal bolt	Stainless steel
13 Washer	Stainless steel
14 Hexagonal nut	Stainless steel
15 Float	DN 80 – 200 Polycarbonat DN 80 – 200 Passivated stainless steel on request
16 O-ring	Elastomer
17 Clamp ring	POM
18 Pipe tail (on request)	PE
19 Insect protective grid (on request)	Stainless steel

DN	A	H	C	d	Weight
80	212	455	230	63	17,0
100	250	505	260	75	25,0
150	387	686			75,0
200	387	686			81,0

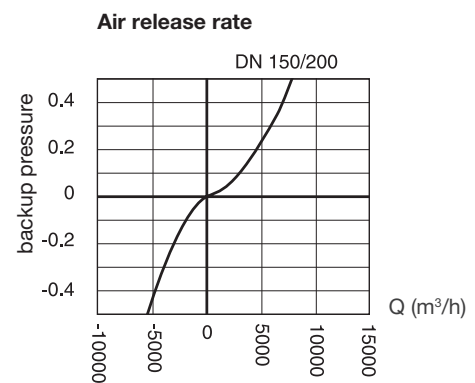
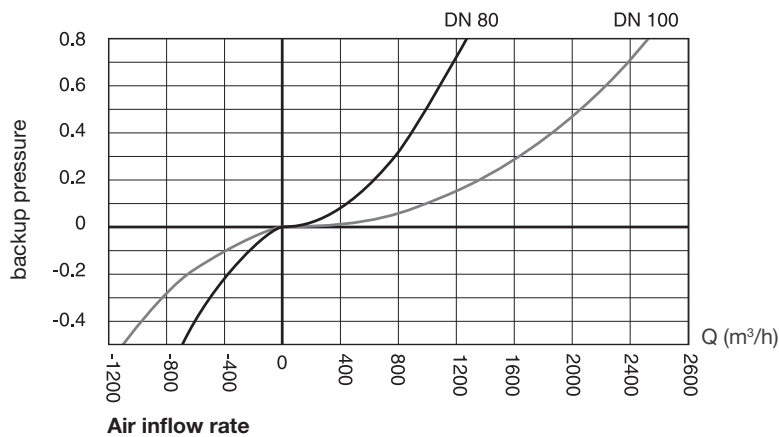

Combined air release valves

Design features

- This arrangement eliminates expensive valve chambers
- The stand pipe protects the automatic air valve
- An automatic shut-off valve enables the equipment to be easily removed for inspection and reinstalled under pressure
- The materials used for the air release valve guarantee absolute corrosion resistance
- Excess water is drained away through an DN ½" ISO-pipe-fitting
- For below-ground installation a surface box with minimum opening of 300 mm diameter is required. Gravel backfilling should be used to prevent rain water from accumulating in the surface box (see Illu. 2 page N 5/2)
- The air release valve can be shortened by 100 mm by cutting the standpipe 5 and extension pipe 3 at the red marks
- Valve only for air release: on request (minimum pressure of 0,3 bar needed)

Material | Technical features

- **Standpipe** made of stainless steel
- **Air release valve** made of POM and brass
- **Max. air release capacity:** 3,2 m³/min
- **Inlet flange:** DN 50 or DN 80 sized and drilled according to EN 1092-2 | PN 16

Suitable accessories

- Surface box No. 1790
- **Flushing stand pipe** including shut-off valve; Instead of the air valve assembly a stand pipe can be supplied for water main flushing and for general water discharge

Order No.	L	Weight	
9824	755	4,70	
	1055	5,80	
	1305	6,75	
	1555	9,50	

L = Total length of the combined air release valve

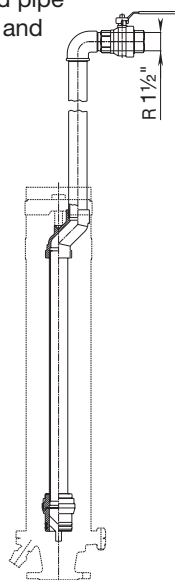

No. 9822

No. 9823



Air valve for releasing air only:
(with air inflow stop) on request
(see over page illu. 3)

Order No.	Working pressure bar	DN	Installation depth		L*	Weight
			Above ground (Illu.1)	Below-ground (Illu.2)		
9822	PN 1 – PN 16	50	0,75 m	1,00 m	755	22,0
			1,00 m	1,25 m	1055	25,5
			1,25 m	1,50 m	1305	29,0
		80	1,50 m		1555	33,5
			0,75 m	1,00 m	755	23,5
			1,00 m	1,25 m	1055	27,0
9823	PN 0,1 – PN 6	50	1,25 m	1,50 m	1305	30,0
			1,50 m		1555	31,0
			0,75 m	1,00 m	755	22,0
		80	1,00 m	1,25 m	1055	25,5
			1,25 m	1,50 m	1305	30,0
			1,50 m		1555	33,0
		80	0,75 m	1,00 m	755	24,0
			1,00 m	1,25 m	1055	28,0
			1,25 m	1,50 m	1305	30,0
			1,50 m		1555	33,0

*L = 100 reducible

Minimum length = 650
Maximum length =

PN 25 on request
2500

Application example

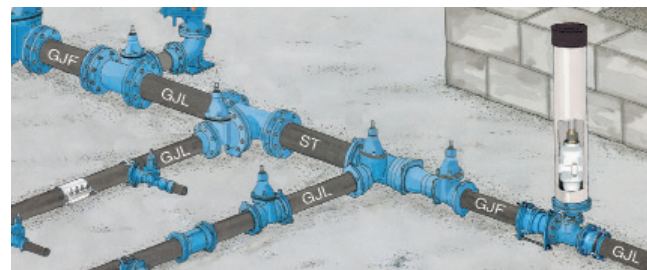

Combined air release valves

Illu. 1

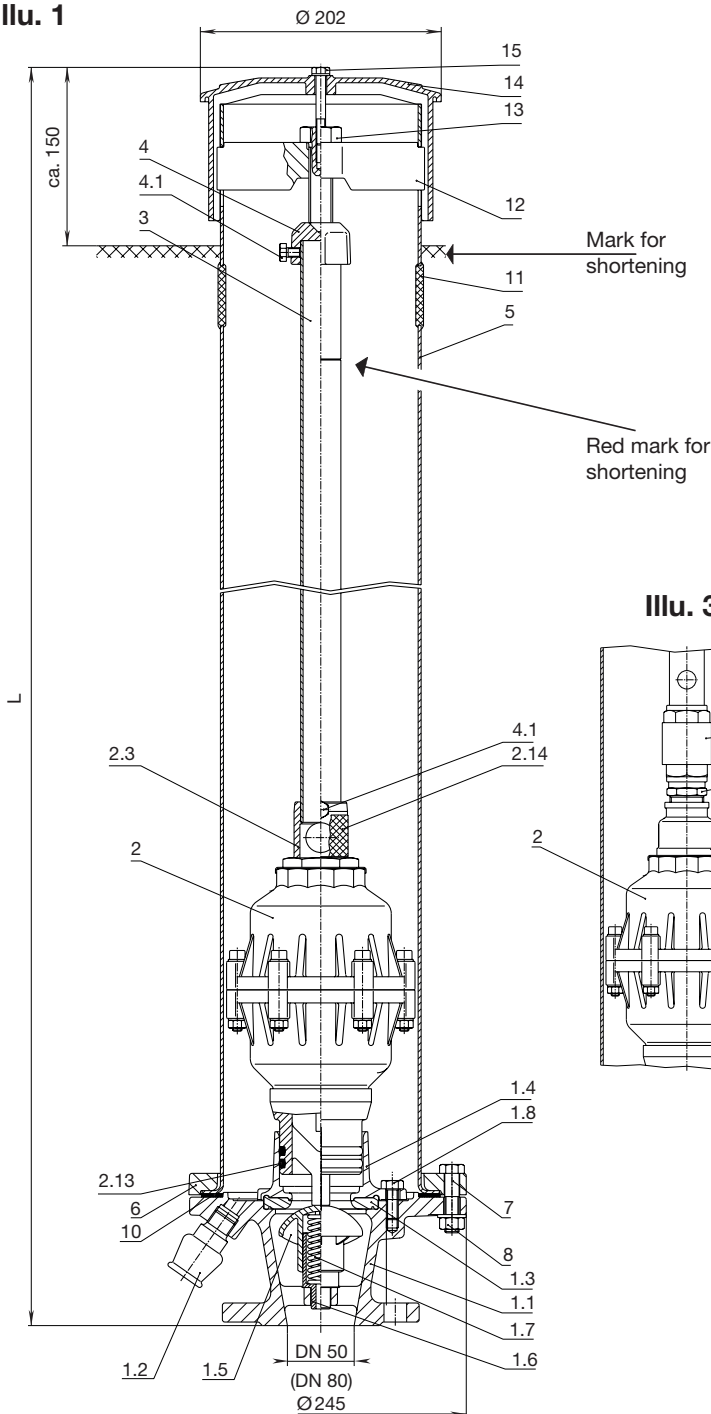

Illu. 2

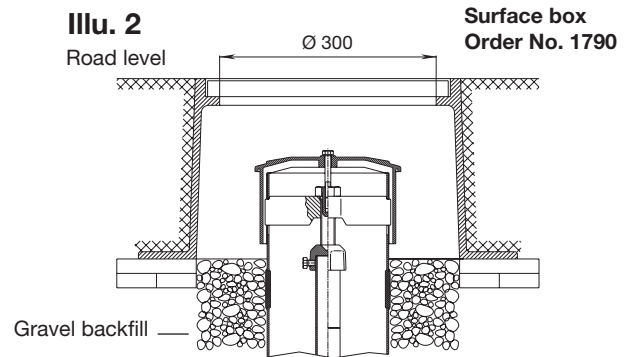

Illu. 3

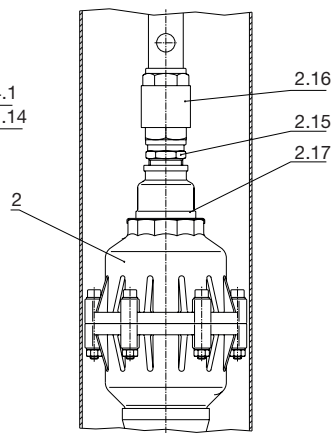

	Parts	Material
1.1	Inlet flange	Ductile iron
1.2	Drain-off fitting	Ductile iron
1.3	Seal	Elastomer
1.4	Foot valve flange	Brass
1.5	Foot valve	POM
1.6	Spring case	POM
1.7	Spring	Stainless steel
1.8	Hexagon bolt M 10	Stainless steel
2	Air valve	see page N 2/1
2.3	Seat	Brass/Elastomer
2.13	O-ring	Elastomer
2.14	Insect protective grid	Stainless steel
2.15	Double nipple	Brass
2.16	Non return valve	Brass
2.17	Reducing socket	Brass
3	Pipe	Stainless steel
4	Coupling	Ductile iron
4.1	Hexagon bolt	Stainless steel
5	Stand pipe	Stainless steel
6	Lock ring	Ductile iron
7	Hexagon bolt M 12 x 55	Stainless steel
8	Hexagon nut	Stainless steel
10	Seal	Elastomer
11	Blind cover	Elastomer
12	Spindle support	
13	Operating bolt	Stainless steel
14	Hood	HDPE
15	Hexagon bolt	Stainless steel

Air release valves

Dynamic PN 10 | PN 16 | PN 25 | PN 40



Design features

- Automatic 3-way air release valve with cylindrical floats
- Ventilation outlet in nominal size (large opening cross-section according to the flange size)
- Flange pursuant to EN 1092-2 (DN 50 can also be shipped with threaded connection 2")
- Efficient, high performance ventilation protects pipeline from vacuum related damages
- High velocity air discharge prevents premature closure, thus safeguarding optimum ventilation during filling process of pipe lines or containers
- 2-level ventilation system provides effective protection against pressure shocks during high ventilation speeds through a small opening
- Continuously reliable ventilation of air inlets under normal operating conditions
- Compact construction, low volume and weight
- Robust and reliable technology

No. 9842K



Order No.	MOP (PN)	Dimension/DN						
		50	80	100	150	200	250	300
9842K	10							
	16							
	25							
	40							

Other dimensions or pressure rating on request

Material | Technical features

- **Body** made of ductile iron, epoxy powder coated inside and outside (see page 4)
- **Sealing rings** made of elastomer
- **All other metallic parts** made of stainless steel
- **Float material** made of PE
- **Medium:** water

Application example



Functional principle

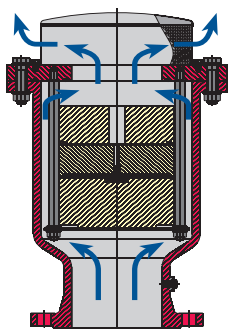

Ventilation of large quantities of air:
During filling, the line will be ventilated via the large cross-section

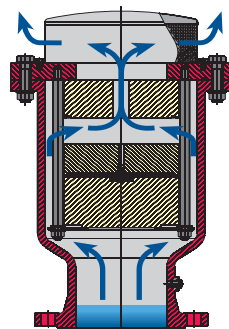

Ventilation at high air velocity through small opening: Prevention of pressure shocks or premature closure

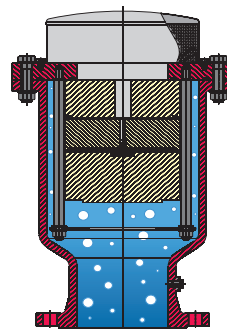

Closure:
After ventilation the valve closes automatically

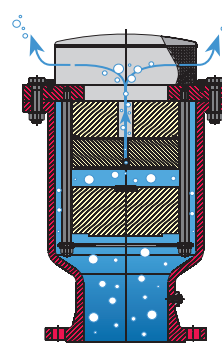

Ventilation of small quantities of air:
During operation of a line, ventilation is carried out via the small cross-section

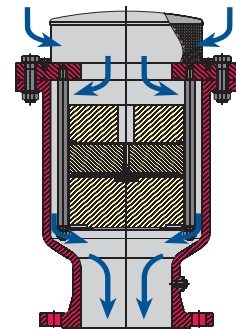

Ventilation:
During drainage of a line, ventilation is carried out via the large cross-section.

Air release valves

Dynamic PN 10 | PN 16 | PN 25 | PN 40

No. 9842K

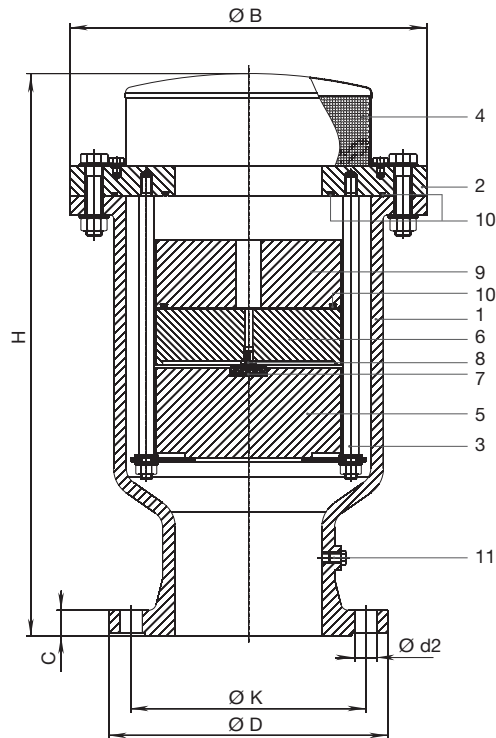

	Parts	Material
1	Body	Ductile iron
2	Bonnet	Steel (stainless steel optional)
3	Float guide	Stainless steel
4	Cover	Stainless steel
5	Float	PE
6	Float	PE
7	Seat seal	Elastomer
8	Seat	Stainless steel
9	Float	PE
10	O-ring	Elastomer
11	Plug	Steel

DN	MOP (PN)	Ø D	Ø K	C	Bolts		Ø B	H	Weight
					Quantity	Ø d2			
50	10/16	165	125	19	4	19	200	355	20
80		200	160	19	8	19	240	420	26
100		220	180	19	8	19	255	420	28
150		285	240	19	8	23	365	580	90
200	10	340	295	20	8	23	410	630	98
200	16	340	295	20	12	23	410	630	98
250	10	405	355	22	12	23	540	820	160
250	16	405	355	22	12	28	540	820	160
300	16	460	410	24,5	12	28	650	927	310

DN	MOP (PN)	Ø D	Ø K	C	Bolts		Ø B	H	Weight
					Quantity	Ø d2			
50	25	165	125	19	4	19	200	355	22
80		200	160	19	8	19	240	420	28
100		235	190	19	8	23	255	420	30
150		300	250	20	8	28	365	580	95

DN	MOP (PN)	Ø D	Ø K	C	Bolts		Ø B	H	Weight
					Quantity	Ø d2			
50	40	165	125	19	4	19	200	355	22
100		235	190	19	8	23	255	420	30