



Integra® CUSA® Excel/CUSA® Excel+

Ultrasonic Surgical Aspirator System

USER'S GUIDE

Integra® CUSA® Excel/CUSA® Excel+ User's Guide

 Integra LifeSciences (Ireland) Limited
IDA Business and Technology Park
Sragh
Tullamore, County Offaly, Ireland

Distributed By:
Integra LifeSciences Corporation
Princeton, NJ 08540 USA

For more information or to place an order, please contact:
Integra ■ 1100 Campus Road, Princeton, NJ 08540
USA and Canada: 800.654.2873 ■ 609.275.0500 (Outside USA)
integralife.com





**CUSA[®] Excel/CUSA[®] Excel+
Ultrasonic Surgical Aspirator
System**

User's Guide

CUSA[®] Excel/CUSA[®] Excel+ Ultrasonic Surgical Aspirator System User's Guide

This User's Guide and the equipment it describes are for use only by qualified medical professionals trained in the particular technique and surgical procedure to be performed. It is intended as a guide for using the CUSA[®] Excel and CUSA[®] Excel+ Ultrasonic Surgical Aspirator System only.

Equipment Covered in this Manual

The CUSA Excel refers to the following product models: CUSA Excel and CUSA Excel-8. Both product models utilize 23 kHz and 36 kHz handpieces.

The CUSA Excel+ refers to the product models: CUSA Excel 2 and CUSA Excel-9. The system incorporates graphic modifications of the logo design and color of the top cover of the system. The CUSA Excel+ System utilizes the same CUSA Excel family of handpieces.

Rx ONLY

Caution

Federal (USA) law restricts this device to sale by or on the order of a physician.

Trademark Acknowledgements

Integra, the Integra logo, CUSA, CUSA Excel, and Tissue Select are registered trademarks of Integra LifeSciences Corporation or its subsidiaries in the United States and/or other countries.

MacroTip, MicroTip, PrecisionTip, SaberTip, CEM, and ShearTip are trademarks of Integra LifeSciences Corporation or its subsidiaries.

Ajax is a trademark of Colgate-Palmolive Company.

Comet is a trademark of The Spic and Span Company.

Klenzyme is a trademark of Steris Corporation.

Enzol is a trademark of ASP Global Manufacturing GmbH.

All other trademarks and trade names are the property of their respective owners.



Manufacturer:

Integra LifeSciences (Ireland) Limited
IDA Business & Technology Park
Sragh
Tullamore, County Offaly, Ireland

Distributed By:

Integra LifeSciences Corporation
Princeton, NJ 08540 USA; 1-800-654-2873



© 2021 Integra LifeSciences Corporation. All Rights Reserved. Contents of this publication may not be reproduced in any form without the written permission of Integra.

Patent Information

U.S. Patents 8,118,823; 8,142,460; 8,518,066; 9,421,027; additional patent(s) pending.

Preface

This User's Guide describes how to use the Integra® CUSA® Excel/CUSA® Excel+ Ultrasonic Surgical Aspirator System. It presents the Integra CUSA Excel/CUSA Excel+ as a system that includes a console, handpieces, and accessories. It describes:

- The System and its functions.
- The Console, its subsystems, and its components.
- The Handpiece and its components.
- How to setup and use the console.
- How to assemble and use the handpiece with the system.

Notice

A technical description of the CUSA Excel/CUSA Excel+ System is provided in the CUSA Excel/CUSA Excel+ System Ultrasonic Surgical Aspirator System Service Manual. The Service Manual is not supplied with the system as it is intended to be used only by Integra service personnel and/or their agents.

System Features

The CUSA Excel/CUSA Excel+ System includes several important features:

- 23 kHz (straight and angled) and 36 kHz (straight) handpieces
- A large variety of 23 kHz and 36 kHz surgical tips that attach to the handpieces:
 - ▶ Sterile, single-use tips
 - ▶ Nonsterile, extended-life tips
- Tissue Select® feature, which increases the selectivity of the surgical tip, allowing greater control and precision.

Organization

This User's Guide is organized into these sections:

- **Section 1: *Patient and Operating Room Safety*** presents the Warnings, Cautions and Notices that you need to read and understand to operate the CUSA Excel/CUSA Excel+ System with maximum safety.
- **Section 2: *Introduction to the CUSA Excel/CUSA Excel+ System*** gives an overview of the console and its functions, and an overview of handpieces and related accessories.
- **Section 3: *Console Components*** describes the console, its subsystems and its components.
- **Section 4: *Control Panel Display and Functions*** describes the control panel display, the signs and symbols on the control panel and the control panel behavior during system startup and operation.
- **Section 5: *Setting Up the CUSA Excel/CUSA Excel+ System*** explains how to prepare the console and its subsystems for use in surgery. It includes the handpiece assembly options; how to prepare the console for startup, connect and test the handpiece, connect the irrigation and suction systems; how to prime the system, adjust settings, and switch to the Run mode.

-
- **Section 6:** *Using CUSA Excel/CUSA Excel+ Console Controls* describes the control panel buttons and functions. It also includes guidelines on using the Tissue Select feature.
 - **Section 7:** *Handpiece Components* presents the items that compose an assembled handpiece, their physical characteristics, and the function of each item. It also presents items that, although not a part of the handpiece itself, are essential in assembling a handpiece or preparing it for sterilization.
 - **Section 8:** *Assembling the Handpiece in a Nonsterile Area* provides step-by-step instructions for assembling the handpiece and preparing it for sterilization.
 - **Section 9:** *Sterilizing Handpieces and Accessories* provides the sterilization parameters you need to ensure that the handpiece is ready for use in the sterile field.
 - **Section 10:** *Completing Handpiece Setup in the Sterile Field* describes how to complete the handpiece assembly in the sterile field.
 - **Section 11:** *Assembling or Changing Tips in the Sterile Field* describes how to attach or change sterile tips in the sterile field.
 - **Section 12:** *Shutting Down the CUSA Excel/CUSA Excel+ System* explains how to turn off the system; disconnect suction tubing, irrigation tubing, and the handpiece; and how to clean the console.
 - **Section 13:** *Disassembling Handpieces* describes how to disassemble and clean the handpiece, and how to clean the tip torquing set.
 - **Section 14:** *Troubleshooting the CUSA Excel/CUSA Excel+ System* offers suggestions for problem solving before or during surgery.
 - **Section 15:** *Maintaining the CUSA Excel/CUSA Excel+ System* describes the maintenance tasks that help to keep the console and handpieces operating as intended.
 - **Appendix A:** *Technical Specifications* provides detailed technical information.
 - **Appendix B:** *Sterilization Validation* provides information on the sterilization validation procedure.
 - **Appendix C:** *Warranty* provides warranty information.

Intended Uses

When you receive your CUSA Excel/CUSA Excel+ System, we recommend that you read and understand all of this User's Guide before using the system. Also, use the guide for:

- **Reference** - When you need specific information on a task. Once you are familiar with the system, use the "Quick Reference" cards (located behind the Control Panel).
- **Training** - When training new personnel to use the system.

To draw immediate attention to matters of importance, this guide presents Warnings, Cautions, Notices, and Important information.

Warning

Indicates a potentially hazardous situation that, if not avoided, could result in serious injury or death, or product damage.

Caution

Indicates a hazardous situation that, if not avoided, could result in minor or moderate injury, or product damage.

Notice

Indicates a hazard that may result in product damage.

Notes

Table of Contents

Section 1. Patient and Operating Room Safety	1-1
Indications for Use	1-1
Contraindication	1-2
Intended Users	1-2
Safety Information	1-2
Warnings, Cautions, and Notices	1-3
Classification and Console Symbols	1-9
Section 2. Introduction to the System	2-1
For Your Information	2-1
About the CUSA [®] Excel/CUSA [®] Excel+ System	2-2
About the Handpieces	2-4
About the Tissue Select [®] Feature	2-6
Sterilization of Handpieces and Accessories	2-9
Section 3. Console Components	3-1
For Your Information	3-1
About the Console and Structural Features	3-2
Console Body – Front Panel	3-4
Console Body – Side Panel	3-7
Console Body – Rear Panel	3-9
About the Power Switches	3-13
Section 4. Control Panel Display and Functions	4-1
For Your Information	4-1
About the Control Panel Display	4-2
Signs and Symbols on the Excel8 and Excel9 Control Panel	4-10
Signs and Symbols on the Excel and Excel 2 Control Panel	4-12
Understanding the Control Panel at System Startup	4-13
Section 5. Setting Up the System	5-1
For Your Information	5-1
Quick Reference – Setup	5-2
Handpiece Assembly Options	5-3
Preparing the System for Startup	5-4
Turning On the System	5-7
Connecting the Suction Tubing	5-7
Connecting the Irrigation Tubing	5-9
Testing the Handpiece	5-11
Testing the Alarm Tone	5-12
When the Surgeon Is Ready	5-13

Section 6. Using the Console Controls 6-1

- For Your Information 6-1
- Adjusting Setpoint Values 6-1
- Changing Functions 6-3
- Using the Tissue Select Feature 6-4
- Using Other Features 6-6

Section 7. Handpiece Components 7-1

- For Your Information 7-1
- Components of Assembled Handpieces 7-2
- Additional Handpiece Components 7-5

Section 8. Assembling the Handpiece in a Nonsterile Area 8-1

- For Your Information 8-1
- Items Needed for Handpiece Assembly 8-3
- Attaching the Tip to the Connecting Body 8-5
- Putting On the O-Rings 8-6
- Clipping the Manifold Tubing to the Handpiece Cable (Optional) 8-7
- Packaging the Handpiece for Sterilization 8-8

Section 9. Sterilizing Handpieces and Accessories 9-1

- For Your Information 9-1
- Sterilization Parameters 9-1
- Sterilizing the Handpiece with Steam 9-3

Section 10. Completing Handpiece Setup in the Sterile Field 10-1

- For Your Information 10-1
- Quick Reference – Setup 10-2
- Completing the Handpiece Assembly 10-2

Section 11. Assembling or Changing Tips in the Sterile Field 11-1

- For Your Information 11-1
- Items Needed to Change Tip in Sterile Field 11-2
- Assembling the Tip 11-5
- Disassembling Handpiece to Change Tips in the Sterile Field 11-10
- Disassembling Handpiece After the Surgical Procedure 11-13
- Resterilizing the Handpiece 11-14
- Resterilizing the Sterilizable Torque Base 11-14
- Packaging the Handpiece for Sterilization 11-15
- Packaging the Base for Sterilization 11-16
- Sterilize the Handpiece and Base 11-17

Section 12. Shutting Down, Disconnecting and Cleaning the Console 12-1

- Shutting Down the System 12-2

Disconnecting Suction Tubing, Irrigation Tubing, and the Handpiece 12-3
Cleaning the Console 12-5

Section 13. Disassembling and Cleaning Handpieces 13-1

For Your Information 13-1
Disassembling the Handpiece 13-2
Cleaning the Handpiece 13-4
Permitted Number of Reprocessing Cycles for Handpieces when Cleaned with an Automatic Washer 13-7
Cleaning the Tip Torquing Set 13-7

Section 14. Troubleshooting the System 14-1

For Your Information 14-1
Responding to Alarms 14-2
General Troubleshooting 14-5

Section 15. Maintaining the System 15-1

For Your Information 15-1
Quick Reference 15-2
Handpiece Maintenance 15-3
Sterilizer Case Maintenance 15-4
Handling and Transporting of the System 15-4
Storage of the System and Accessories 15-5
Disposal of the Equipment 15-5
Return Equipment for Service 15-5
Integra Service Centers 15-7

Appendix A. Technical Specifications A-1

Console Dimensions A-1
Console Subsystems A-2
Electrical Requirements A-3
Environment A-4
Voluntary Standards A-5
Handpieces A-11
Tip Specifications A-11

Appendix B. Sterilization Validation B-1

Validation of Steam Sterilization Parameters B-1

Appendix C. Warranty C-1

Notes

List of Figures

- Figure 3-1. Console – Front View **3-2**
- Figure 3-2. Console Body – Front Panel **3-4**
- Figure 3-3. Console Body – Side Panel **3-7**
- Figure 3-4. Console Body – Rear Panel **3-9**
- Figure 3-5. Console Body – Rear Panel Continued **3-10**
- Figure 4-1. Control Panel for Excel8 and Excel9 models **4-2**
- Figure 4-2. Control Panel for Excel and Excel 2 model **4-3**
- Figure 4-3. Control Panel – Excel8 and Excel9 model (status indicators and setpoint adjustment) **4-6**
- Figure 4-4. Control Panel – Excel and Excel 2 model (status indicators and setpoint adjustment) **4-7**
- Figure 5-1. The assembled suction system **5-8**
- Figure 5-2. The assembled irrigation system **5-10**
- Figure 7-1. The components of a handpiece **7-2**
- Figure 7-2. Tip torquing base and torque wrench for use when changing tips in the nonsterile field **7-5**
- Figure 7-3. The sterilizable torque bases for use when changing tips in the sterile field **7-6**
- Figure 7-4. The sterile torque wrench for use when changing tips in the sterile field **7-7**
- Figure 7-5. The 23 kHz CUSA Excel/CUSA Excel+ handpiece sterilizer case **7-8**
- Figure 8-1. The items you need to assemble a handpiece: handpiece, nosecone, and tip pack **8-3**
- Figure 8-2. Tip torquing base and torque wrench (for use in non-sterile field) **8-4**
- Figure 8-3. Manifold tubing **8-4**
- Figure 8-4. The sterilizer case **8-9**
- Figure 8-5. The handpiece and connector secured into the sterilizer tray **8-10**
- Figure 11-1. The sterilized handpiece **11-2**
- Figure 11-2. The sterilized standard nosecone **11-3**
- Figure 11-3. Sterile tip/flue pack contents. The tip cleaner is inside the flue. **11-3**
- Figure 11-4. Sterilizable tip torquing base **11-4**
- Figure 11-5. Sterile torque wrench (23 kHz or 36 kHz) **11-4**
- Figure 11-6. Sterile manifold tubing **11-4**
- Figure 11-7. The handpiece and connector secured into the sterilizer tray **11-16**
- Figure 15-1. Replacing o-ring on the handpiece connector water prongs **15-4**

Notes

Patient and Operating Room Safety

In this section:

- Indications for Use, page 1-1
- Contraindication, page 1-2
- Intended Users, page 1-2
- Safety Information, page 1-2
- Warnings, Cautions, and Notices, page 1-3
- Classification and Console Symbols, page 1-9

Indications for Use

The CUSA[®] Excel/CUSA[®] Excel+ Ultrasonic Surgical Aspirator System is indicated for use in these surgical procedures where fragmentation, emulsification and aspiration of soft and hard tissue is desirable:

- Neurosurgery
- Gastrointestinal and affiliated organ surgery
- Urological surgery
- General surgery
- Orthopedic surgery
- Gynecological surgery
- Laparoscopic surgery

Contraindication

This ultrasonic surgical aspirator device is not indicated for and should not be used for the fragmentation, emulsification, and aspiration of uterine fibroids.

Warning

The CUSA Excel/CUSA Excel+ System cannot be used in an MRI (Magnetic Resonance Imaging) environment.

Warning

No modification of this equipment is allowed.

Notice

When you receive the CUSA Excel/CUSA Excel+ System and accessories, if any component is damaged, contact your Integra service representative for assistance. If the packaging for a sterile accessory is damaged, do not use the sterile accessory.

Intended Users

The intended users of this guide and the equipment it describes are qualified medical professionals who are trained in the particular surgical technique and surgical procedure to be performed, and trained in the use of this equipment. The CUSA Excel/CUSA Excel+ System should only be used in a surgical environment by qualified medical professionals.

Warning

It is the responsibility of the Healthcare Facility to ensure that intended users of CUSA Excel/CUSA Excel+ System are appropriately trained in the use of this equipment.

Safety Information

The safe and effective use of ultrasonic surgery depends to a large degree on factors solely under the control of the operator. Only medical professionals that are properly trained in the use of ultrasonic equipment should operate the CUSA Excel/CUSA Excel+ System. It is important that medical professionals read, understand, and follow the operating instructions supplied with this equipment.

Before starting any surgical procedure, medical professionals should be familiar with the medical literature, complications, and hazards of using ultrasonic surgery in that procedure.

Warnings, Cautions, and Notices

To promote the safe use of the CUSA Excel/CUSA Excel+ System, this section presents the warnings, cautions, and notices that appear throughout this User's Guide. To operate this equipment with maximum safety, it is important to read, understand, and follow the instructions in these warnings, cautions, and notices.

Patient and Operating Room Safety

Warning

The CUSA Excel/CUSA Excel+ System cannot be used in an MRI (Magnetic Resonance Imaging) environment.

No modification of this equipment is allowed.

It is the responsibility of the Healthcare Facility to ensure that intended users of CUSA Excel/CUSA Excel+ System are appropriately trained in the use of this equipment.

Notice

When you receive the CUSA Excel/CUSA Excel+ System and/or accessories, if any component is damaged, contact your Integra service representative for assistance.

Introduction to the System

Warning

Single Use devices are for single patient use only. Do not reprocess or re-use.

Devices (s) is (are) intended to be used for one procedure only. If reprocessed or re-used this may result in the infection of patient (or patient specimen) through cross-contamination, as well as would incur the risk of modifying the properties and performance of the device, and of increasing the likelihood of complications and/or undesirable effects. Once used, devices must be disposed of in accordance with hospital policies.

Only use Integra handpieces and accessories with the CUSA Excel/CUSA Excel+ System. Non-Integra handpieces and accessories are not supported.

Caution

Read the instructions, warnings, cautions, and notices provided with the CUSA Excel/CUSA Excel+ System before use. Otherwise injury to the patient or user or equipment damage may result.

Console Components

Warning

Ignoring alarms on the CUSA Excel/CUSA Excel+ System while continuing to use the system may result in injury to the patient and/or surgical personnel, or equipment damage.

To avoid injury to surgical personnel, keep fingers away from the suction pinch valve.

TO AVOID RISK OF ELECTRIC SHOCK, THIS EQUIPMENT MUST ONLY BE CONNECTED TO A SUPPLY MAINS WITH PROTECTIVE EARTH.

When you connect the handpiece to the console, the handpiece becomes a functional surgical device.

The power cord complies with the Directive EU 2015/863 amending Annex II to directive 2011/65/EU the restriction of the use of certain hazardous substances in electrical and electronic equipment (recast).

Setting Up the System

Warning

When the handpiece is connected to a CUSA Excel/CUSA Excel+ System that is powered on, but the handpiece is not in use, keep the handpiece away from the patient. Place the handpiece on a sterile, flat, dry, nonconductive, and highly visible surface.

Inadvertent contact between handpiece accessories and the patient may result in burns.

Do not use a damaged handpiece with the CUSA Excel/CUSA Excel+ System. This may result in injury to the patient or surgical personnel.

Ignoring alarms on the CUSA Excel/CUSA Excel+ System while continuing to use the system may result in injury to the patient and/or surgical personnel, or equipment damage.

To avoid injury to surgical personnel:

When closing the irrigation pump latch, keep fingers away from the area between the V-shaped tubing retainers.

If the pump latch is open, keep fingers away from the pump rollers.

To avoid injury to surgical personnel, keep fingers away from the suction pinch valve.

When you connect the handpiece to the console, the handpiece becomes a functional surgical device.

The handpiece and handpiece accessories must be sterile before surgical use.

Warning

Touching of the tip of the handpiece by the operator, while the handpiece is powered on, can result in personal injury.

When the handpiece is powered on, contact of the tip with a hard surface (e.g. a metal instrument, tray, staples, clips, instruments, etc) may damage the tip of the handpiece and require replacement before use.

CUSA Excel tips utilize silicone flues. Compressing the flue against the side of the vibrating surface along the length of the tip can cause excessive heating and potential hazard to adjacent tissue, such as burns.

Excessive loading of CUSA Excel tips at the surgical site can induce heating due to vibration and acoustic power transmissions. Thermal management of the surgical site with the aid of the appropriate irrigation and aspiration settings is essential.

Avoid excessive lateral loading of CUSA Excel tips.

Avoid contacting bone with the CUSA Excel tips (excluding SaberTip™).

Caution

When you test the handpiece, do not allow the handpiece tip to contact anyone or anything during tip activation. Contact may result in patient injury, user injury, or handpiece tip damage.

During surgery, under maximum loading conditions, the CUSA Excel/CUSA Excel+ console is suitable for ultrasonics activation times of 10 minutes on, 5 minutes off.

Sharp edge at the handpiece connection point.

Make sure that the irrigation tubing centers between the V-shaped tubing retainers before you close the pump latch. Otherwise, the pump latch will pinch the tubing, preventing the flow of irrigation fluid.

Before surgery, apply the brakes locks to all wheels on the console to stop the wheels from rolling.

Notice

To prevent fluid flowing into the vacuum line, only use a canister that has a non-return valve.

During surgery, do not allow the handpiece tip to touch metal objects such as staples, clips, instruments, etc. Handpiece tip damage will result.

Using the Console Controls

Warning

Ignoring alarms on the CUSA Excel/CUSA Excel+ System while continuing to use the system may result in injury to the patient and/or surgical personnel, or equipment damage.

Handpiece Components

Warning

Do not use the sterile wrench for more than one surgical procedure.

Assembling the Handpiece in a Nonsterile Area

Warning

Turning the torque wrench further clockwise will damage the handpiece.

Caution

Do not assemble the nonecone to the handpiece until you have sterilized the handpiece.

To avoid product damage, NEVER hold the handpiece in your hand while using the torque wrench to tighten or loosen the tip.

Notice

Do not sterilize the C5600 tip torquing base or the associated the torque wrench because it destroys the lubrication in the torquing mechanism, resulting in product damage.

Completing Handpiece Setup in the Sterile Field

Notice

Retaining a spare handpiece in the sterile field is highly recommended.

Assembling or Changing Tips in the Sterile Field

Warning

The handpiece and handpiece accessories must be sterile before surgical use.

Before use, sterilize the sterilizable torque base in the sterilizer tray.

Turning the torque wrench further clockwise will damage the handpiece.

Caution

To avoid product damage, NEVER hold the handpiece in your hand while using the torque wrench to tighten or loosen the tip.

Shutting Down, Disconnecting and Cleaning the System

Warning

Electric Shock Hazard – Always unplug the CUSA Excel/CUSA Excel+ System before cleaning it.

Sharp edge at the handpiece connection point.

Notice

Do not disconnect the handpiece until the control panel goes completely blank. Otherwise, product damage may result.

Do not rub, press, or touch any panels with solvents; caustic, corrosive, or abrasive cleaning or disinfectant compounds, or other materials that could scratch the panels. Do not use a betadine-based solution because it will cause discoloration.

Do not allow fluids to enter the console.

Disassembling Handpieces

Caution

To avoid product damage, NEVER hold the handpiece in your hand while using the torque wrench to tighten or loosen the tip.

Product damage will result if you do not follow these notices when cleaning the handpiece:

Do not immerse the handpiece cable electrical connector in liquid

Do not use ultrasonic washers

Do not use chlorinated substances such as bleach solution

Do not clean the handpiece with abrasives such as Ajax[®], Comet[®], or steel wool

Product damage will result if you do not follow these notices when cleaning the Tip Torquing Set:

Do not use ultrasonic washers

Do not autoclave

Do not use chlorinated substances such as bleach solution

Do not clean with abrasives such as Ajax, Comet, or steel wool

Maintaining the System

Notice

Do not clean the sterilizer case with abrasives. Product damage will result.

To avoid product damage, use proper packaging materials and packing procedures when preparing the console for shipment. Failure to return product in this manner may void the warranty and/or damage the product. Contact Integra for details.

Appendix A. Technical Specifications

Warning









Explosion Hazard – Do not use the CUSA Excel/CUSA Excel+ System in the presence of flammable anesthetics or any potentially explosive or flammable atmosphere.









To avoid injury to surgical personnel, keep fingers away from the suction pinch valve while powering the unit on or off, activating vibration, or using fast flush.





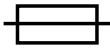



TO AVOID RISK OF ELECTRIC SHOCK, THIS EQUIPMENT MUST ONLY BE CONNECTED TO A SUPPLY MAINS WITH PROTECTIVE EARTH.



The console must be earthed and therefore it **MUST** only be fitted with a 3-pin plug, or a 2-pin plug that has an integral earth grounding connection. Mains plug type and construction **MUST** comply with Legal requirements within country of installation. Only Integra Service personnel or Integra authorized representatives or agents can change the mains plug on the console.

Classification and Console Symbols

Symbol	Description
Console Symbols	
	Warning: When you connect the handpiece to the console, the handpiece becomes a functional surgical device.
	Warning: Dangerous Voltage To reduce the risk of electric shock, do not remove the cover. Refer servicing to qualified service personnel. Classified with respect to electrical shock, fire, mechanical, and other specified hazards only in accordance with UL60601-1 and CAN/CSA C22.2 No. 601.1.
	Follow Instructions for Use
	Cooling Reservoir: Do not fill the Cooling Reservoir with tap water or saline solution. Use distilled water only.
	Do not insert fingers. Pinch Point can cause injury. Warning To avoid injury to surgical personnel, keep fingers away from the suction pinch valve while powering the unit on or off, activating vibration, or using fast flush.
	Consult Instructions for Use
	Equipotentiality: Connect equipotential ground cable here.
	Protective earth (ground)

Symbol	Description
	<p>Class I Equipment (IEC 601-1)</p> <p>Accessible conductive parts cannot become live in the event of a basic insulation failure because of the way in which they are connected to the protective earth conductor Type BF Applied Part Equipment (IEC 601-1)</p> <p>The CUSA Excel/CUSA Excel+ System console provides a high degree of protection against electric shock, particularly regarding allowable leakage currents. It is type BF isolated (floating) output. The handpiece, cord and tip are applied parts.</p> <p>IPX - 8 (IEC 529, UL60601) Footswitch</p> <p>IPX - 0 (IEC 529, UL60601) Console</p> <p>The CUSA Excel/CUSA Excel+ System footswitch includes protection against the effects of continuous immersion in water.</p>
	<p>ON (power)</p> <p>Applies power at the AC Main Switch and the System Power Switch.</p>
	<p>OFF (power)</p>
	<p>System Power Off / Standby</p> <p>When you turn off the System Power Switch, the system automatically drains water from the cooling water system and deactivates other system components. It also maintains power to the logic circuitry to monitor the System Power Switch position.</p>
	<p>Fuse Replacement</p> <p>Indicates the location of the fuse drawer on the rear panel.</p>
	<p>Volume Control</p>
	<p>Footswitch Connector</p>
	<p>Manufacturer</p>

Symbol	Description
	Catalogue Number
	Serial Number
	Please dispose of in accordance with local regulations for the collection or disposal of waste electrical and electronic equipment.
Rx ONLY	Caution: Federal (USA) law restricts this device to sale by or on the order of a physician.
	Temperature Limitation: Indicates upper and lower temperature limits
	Humidity Limitation: Indicates upper and lower humidity limits
	Recyclable material
	UL Certification used in conjunction with the INMETRO Mark of the National Institute of Metrology, Standardization and Industrial Quality in Brazil.
	GOST R Russian mark of conformity
Footswitch Symbols	
	Activate vibration

Symbol	Description
	Activate fast flush (irrigation)
NOT FOR HUMAN USE	Accessories marked with the 'NOT FOR HUMAN USE' label are supplied for demonstration purposes only .
	Do not push, lean or rest against the control panel, or against the front or sides of the console. When moving the console, push the console using the handle only.

Introduction to the System

In this section:

- For Your Information, page 2-1
- About the CUSA[®] Excel/CUSA[®] Excel+ System, page 2-2
- About the Handpieces, page 2-4
- About the Tissue Select[®] Feature, page 2-6
- Sterilization of Handpieces and Accessories, page 2-9

For Your Information

Caution

Read the instructions, warnings, cautions, and notices provided with the CUSA[®] Excel/CUSA[®] Excel+ System before use. Otherwise, injury to the patient or user or equipment damage may result.

This section presents general information about the CUSA Excel/CUSA Excel+ Ultrasonic Surgical Aspirator System: what it is, what it does, and how it works. It also describes the handpiece functions, configurations, and the sterilization requirements for the handpiece and accessories.

For complete instructions on handpieces and accessories, see Section 7 to Section 11.

About the CUSA[®] Excel/CUSA[®] Excel+ System

The CUSA Excel/CUSA Excel+ System is an ultrasonic surgical aspirator that allows a surgeon to remove tissue – selectively and with greater control. It performs three functions:

- Fragmentation
- Irrigation
- Aspiration (Suction)

All three functions may occur at the same time.

The system includes the following components:

- **Console:**
 - ▶ The Console Body houses electronics, pumps, and mechanical parts.
 - ▶ The Control Panel allows the user to control the functions of the system.
- **Handpiece:** a handheld surgical device with a tip that is applied to patient tissue.
- **Accessories:** manifold tubing, tips, tip torquing bases, torque wrenches, sterilizer cases and contamination guard.

You can also combine the CUSA Excel System with electrosurgery using the optional CUSA Electrosurgical Module (CEM[™]). Refer to the Instructions for Use for the CEM for details.

When you receive the CUSA Excel System, the shipment contains accessories that are marked with the label 'NOT FOR HUMAN USE'. Accessories marked with the 'NOT FOR HUMAN USE' label are supplied for **demonstration purposes only**.

Fragmentation

Electromechanical Operation

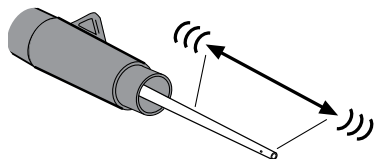

The console provides alternating current at 23 or 36 thousand cycles per second (kHz) to the handpiece (the frequency depends on which handpiece you connect to the console). In the handpiece, the current passes through a coil, which induces a magnetic field. The magnetic field excites a transducer of nickel alloy laminations, resulting in an oscillating motion in the transducer laminated structure – vibration – along its long axis (refer to the figure at left). The transducer vibrates at 23 or 36 kHz.

The transducer transmits vibrations through a metal connecting body to an attached surgical tip. The frequency of vibration remains the same at the tip (23 or 36 kHz), but the amount of motion (amplitude) at the tip varies: lower frequency, greater amplitude; higher frequency, smaller amplitude.

Amplitude also varies with the transducer/connecting body/tip configuration: handpiece angles reduce tip amplitude.

When the vibrating tip contacts tissue, it breaks cells apart (fragments them).

Cooling

The high frequency vibration generates heat. To reduce the heat, the system includes a closed, recirculating cooling water system. This system pumps water from a cooling water reservoir, through a tube in the handpiece cable, through the handpiece, and through a return tube in the handpiece cable to the cooling water reservoir. Cooling water flows at 35 to 50 ml/min.

As it passes through the handpiece, the water removes heat. Normal handpiece temperature, in sustained heavy use, remains at less than 40°C/104°F.

Use distilled water for the cooling water system. Do not use tap water because it contains impurities (natural minerals, chemical additives, or organic materials) that can cause problems within the cooling water system.

Irrigation

Sterile irrigation fluid flows from an IV set (bottle or bag and IV administration tubing) to a variable speed peristaltic pump. The pump:

- Moves fluid at 1 to 10 ml/min; default flow is 3 ml/min. Use the adjustment buttons (blue up/down arrows on black buttons at the bottom of the irrigation display column on the control panel) to increase or decrease the irrigation flow.
- Accelerates to a Fast Flush speed, pumping at greater than 25 ml/min. The Fast Flush pedal on the system footswitch activates the Fast Flush feature.

The accuracy of the irrigation flow is +/- 20% of setting or +/-1 ml/min, whichever is greater.

The pump pushes the fluid through the manifold irrigation tubing to a flue, a sleeve surrounding the vibrating tip. As the irrigation fluid passes through the flue, it cools the tip.

When the fluid reaches the distal end of the tip, as much as 99% of it passes through two pre-aspiration holes in the tip, eliminating fluid pooling in the sterile field and continually clearing the suction system. Fluid that does not pass through the pre-aspiration holes irrigates the surgical site and suspends fragmented tissue.

Aspiration (Suction)

A vacuum pump in the console body provides up to 26 inHg/660 mmHg maximum vacuum at sea level. Use the adjustment buttons (green up/down arrows on black buttons at the bottom of the aspiration display column on the control panel) to increase or decrease the suction from 10 to 100% in 10% increments.

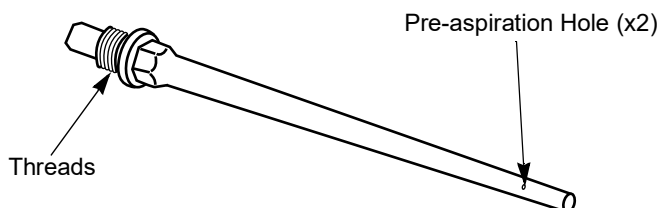

The suction, which produces an air stream moving toward the vacuum pump, pulls irrigation fluid, fragmented tissue, and other materials through the distal end of the surgical tip. From the tip, the aspirated materials pass through the manifold suction tubing into the suction canister. From the suction canister, the air stream continues to flow through a contamination guard that filters any remaining particulate matter or moisture, preventing them from entering the vacuum pump.

The accuracy of the vacuum level between contamination guard and vacuum pump inlet is $\pm 15\%$ of scale setting or ± 2.6 inHg/ 66 mmHg, whichever is greater.

A suction pinch valve on the front of the console opens when the system is on, and closes to stop suction when:

- Priming the irrigation system
- Pressing the Fast Flush pedal
- Releasing the Vibration pedal in Run Status (in this case, the pinch valve closes for approximately one second, then re-opens).
- Releasing the Vibration pedal in Lap Mode (this suction stoppage prevents depletion of the pneumoperitoneum).

When the System Power Switch is off, the suction pump remains off and the suction pinch valve remains closed. Use the button on the front of the suction pinch valve to open the valve manually.

About the Handpieces

Warning

Only use Integra[®] handpieces and accessories with the CUSA Excel/CUSA Excel+ System. Non-Integra handpieces and accessories are not supported.

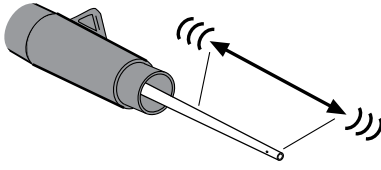

A CUSA Excel/CUSA Excel+ handpiece is a handheld surgical device. It houses a transducer that vibrates at an ultrasonic frequency, transferring the vibrations to a hollow titanium tip. The figure (on left) shows the direction of vibration.

When applied to patient tissue, the vibrating tip provides the desired surgical effect – the fragmentation and removal of specific tissue.

The handpiece connects to the console by a handpiece cable and by manifold tubing:

- The cable consists of electric wires that power the transducer, and two water tubes. The circulating water removes heat from the vibrating transducer.
- The disposable manifold tubing consists of a tube for sterile irrigation fluid, which the console pumps to the handpiece, and a tube for suction. Clips on the manifold tubing fasten the tubing to the handpiece cable.

Handpiece Functions

Together, a handpiece and CUSA Excel/CUSA Excel+ console form an ultrasonic surgical aspirator system. This system has three functions:

- **Fragmentation:** As the vibrating tip contacts tissue, the vibrations break the tissue cells into fragments.
- **Irrigation:** Sterile irrigation fluid, pumped from the console through the manifold tubing, suspends the fragmented cells so that suction can easily remove them and prevent tip blocking. The irrigation fluid also cools the vibrating tip.
- **Aspiration (Suction):** Suction through the hollow tip removes the fragmented tissue and irrigation fluid from the surgical site.

All three functions can occur at the same time.

Handpiece Configurations

The CUSA Excel/CUSA Excel+ System includes three handpiece configurations:

- 36 kHz, straight (smaller handpiece, black body, blue connector)
- 23 kHz, straight (gray body, green connector)
- 23 kHz, angled (gray body, green connector).

Notice

The 36kHz handpiece operates within a frequency range and 36kHz is a representative value. Refer to the Technical Specification section for the frequency range.

Handpiece Tips

A variety of handpiece tips are available. Tips vary in inside diameter, length, and shape (straight or curved). For information on the tips available for each handpiece, contact your Integra representative.

About the Tissue Select[®] Feature

The Tissue Select[®] feature allows the surgeon to maintain a high fragmentation rate while increasing selectivity and control at the surgical site.

Fragmentation occurs when the vibrating tip interacts with tissue. As the tip begins to move toward tissue, it accelerates, then impacts and penetrates the tissue. The acceleration, impact, and penetration produce a combination of direct mechanical forces and hydrodynamic pressures that burst cells.

Several variables affect the fragmentation rate. Most are functions of the CUSA Excel/CUSA Excel+ System:

- Stroke (tip excursion—the total distance the tip travels) – greater stroke results in greater fragmentation rate
- Suction
 - ▶ Suction has two functions:
 - (1) It draws tissue toward the vibrating tip and creates a tip/tissue coupling effect.
 - (2) It removes irrigation and fragmentation debris from the surgical site.
 - ▶ If there is no suction or low suction, coupling does not occur, resulting in minimal tissue fragmentation and increased tissue temperature.
- Tip acceleration – produces the peak forces and pressures that fragment tissue.
- Tip cross-sectional area at the tip-tissue contact site

These variables also affect tactile feedback—what the surgeon's hand feels when using the handpiece.

Inherent Tissue Selectivity

With all other variables remaining constant, the tip does not fragment all tissue types equally effectively. Another variable – tissue strength – affects fragmentation rate.

- “Low strength” soft tissues that are easiest to fragment include the brain and most organs. Older, partially dried tissues are also easy to fragment “High strength” strong tissues that are most difficult to fragment include vessel structures, tendons, ligaments, healthy skin, and organ capsules.

- Strength increases and fragmentation rate decreases with tissue containing greater collagen, elastin, or both (collagen type, quantity, and organization affect cell structural quality).

Tissue strength also affects tactile feedback. The surgeon can feel a difference between the tip contacting low strength tissue and the tip contacting high strength tissue. As the tip works through low strength tissue, the surgeon feels a smooth, rhythmic sensation from the handpiece. When the tip contacts high strength tissue, it feels like it is "bouncing off" the tissue. Also, the smooth, rhythmic sensation becomes rougher. To avoid fragmenting high strength tissue, the surgeon must apply less pressure to the tip or move the tip away from the tissue. To continue fragmenting high strength tissue, the surgeon must manually apply more pressure.

In Standard Mode, continued manual pressure could result in unintentional damage to critical structures. Using the Tissue Select feature, the CUSA Excel/CUSA Excel+ System can help the surgeon avoid these problems when dissecting near critical structures.

Increasing Tissue Selectivity

It is possible to increase the inherent selectivity resulting from variations in tissue strength while maintaining stroke amplitude, tip acceleration, and suction. This increase in selectivity results from reducing the reserve power that drives the tip. Remember: The ultrasonic generator delivers electrical power (which is directly related to the acoustic power present at the tip, which results in fragmentation) to the handpiece. Consider the power delivered to the handpiece in three terms:

- Initial power – the quantity of power necessary to drive the tip vibration in air; that is, no contact with tissue
- Reserve power – the power necessary to maintain tip vibration under load (in contact with tissue). When the tip encounters load, a feedback loop in the system senses the additional load and provides additional reserve power to maintain tip vibration.
- Maximum power – the greatest power output the console can provide. Maximum power is the sum of initial and reserve power.

A Common Misunderstanding of the Amplitude Setting

It has been common practice to decrease the amplitude setting when encountering critical structures. The reasoning behind this practice is that the lower amplitude setting results in slower fragmentation rate and greater selectivity, thus greater control to help avoid damage when dissecting near the critical structures. Consider this reasoning more carefully:

True: Decreasing the amplitude setting also decreases the fragmentation rate.

True: Because the fragmentation rate is slower, the surgeon has a little more time to move the tip away from a critical structure before damaging it; therefore, the surgeon *seems* to have greater selectivity and control.

False: The surgeon gains greater selectivity, thus greater control and precision, when dissecting near critical structures.

Why does the decrease in amplitude not give greater selectivity and control? Decreasing the amplitude does not greatly affect the reserve power.

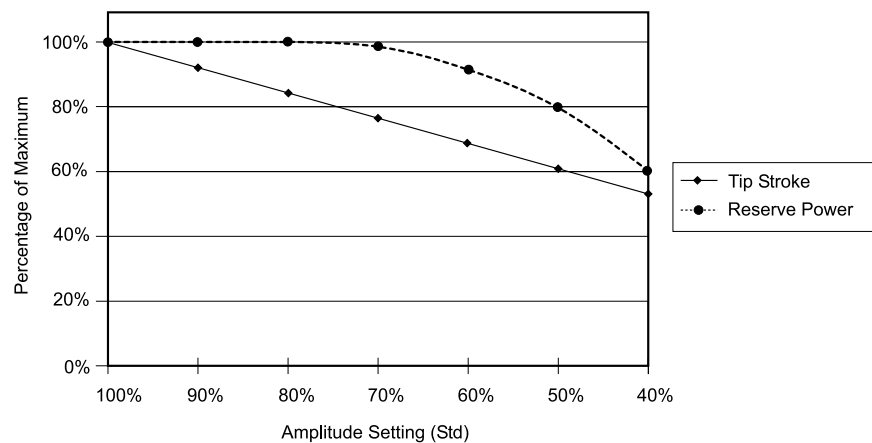

Decreasing the amplitude leaves plenty of reserve power.

When the tip contacts critical structures, it still has more than enough power to fragment them if the surgeon applies pressure or prolongs the tip-tissue contact. Therefore, decreasing the amplitude setting gives the following results:

- Reduced fragmentation ability
- Reduced fragmentation rate
- Little increase in selectivity
- Little reduction in reserve power

Benefits of the Tissue Select Feature

The Tissue Select feature presents several benefits:

- Maintains fragmentation ability
- Reduces (automatically) fragmentation rate

- Provides maximum tissue selectivity
- Gives surgeon superior tactile feedback
- Gives surgeon greater control and precision when dissecting near delicate structures

For information on using the Tissue Select feature, see *Using the Tissue Select Feature*, page 6-4.

Sterilization of Handpieces and Accessories

You must sterilize the CUSA Excel/CUSA Excel+ handpiece with steam before use. Some of the CUSA Excel/CUSA Excel+ System accessories are sterile, single-use items. Other accessories are reusable. You must sterilize all reusable accessories with steam before use.

Notice

Before sterilization, refer to handpiece cleaning and reprocessing information, see *Cleaning the Handpiece*, page 13-4.

Table 2-1 describes the sterilization requirements for the handpiece and accessories. For information on the sterilization parameters and sterilization procedure for the handpieces and accessories, see *Sterilization Parameters*, page 9-1.

Table 2-1 Handpiece and Accessory Sterilization

Item	Supplied Sterile	Reusable /Requires Sterilization by the User	Permitted Number of Sterilizations	Sterilization Method
Handpieces	No	Yes	Varies per handpiece and sterilization cycle. See Cleaning the Handpiece, page 13-4 and Permitted Number of Reprocessing Cycles for Handpieces when Cleaned with an Automatic Washer, page 13-7 Note: See "Recalibrate the Handpiece" on page 15-3.	Steam
Standard nosecone	No	Yes	Unlimited	Steam
Extended Life Tip (ELT)	No	Yes	Six	Steam
ELT Flue	No	Yes	One	

Item	Supplied Sterile	Reusable /Requires Sterilization by the User	Permitted Number of Sterilizations	Sterilization Method
Standard Tip and Flue	Yes	No - Single patient use only	One* *Note: The sterile tips are for single patient use only. Each tip can be resterilized <u>once before use</u> but the tip cannot be reused or reprocessed.	Not applicable
MicroTip™ and Flue	Yes	No - Single patient use only		Not applicable
Extended Length MicroTip™ Plus	Yes	No - Single patient use only		Not Applicable
MacroTip™ and Flue	Yes	No - Single patient use only		Not applicable
SaberTip™ and Flue	Yes	No - Single patient use only		Not applicable
ShearTip™ and Flue	Yes	No - Single patient use only		Not applicable
Manifold Tubing	Yes	No - Single patient use only	One* *Note: The manifold tubing is for single patient use only. It can be resterilized <u>once before use</u> but it cannot be reused or reprocessed.	Steam
Sterile Torque Wrench	Yes	No - Single patient use only	None	Not applicable
Sterilizable Torque Base	No	Yes	Unlimited	Steam

Item	Supplied Sterile	Reusable /Requires Sterilization by the User	Permitted Number of Sterilizations	Sterilization Method
Tip Torquing Set	No	Reusable only. The tip torquing set only used outside of the sterile field.	None	Not applicable

Warning

Single Use devices are for single patient use only. Do not reprocess or re-use. Devices (s) is (are) intended to be used for one procedure only. If reprocessed or re-used this may result in the infection of patient (or patient specimen) through cross-contamination, as well as would incur the risk of modifying the properties and performance of the device, and of increasing the likelihood of complications and/or undesirable effects. Once used, devices must be disposed of in accordance with hospital policies.

Console Components

In this section:

- For Your Information, page 3-1
- About the Console and Structural Features, page 3-2
- Console Body – Front Panel, page 3-4
- Console Body – Side Panel, page 3-7
- Console Body – Rear Panel, page 3-9
- About the Power Switches, page 3-13

For Your Information

This section presents the console for the CUSA[®] Excel/CUSA[®] Excel+ Ultrasonic Surgical Aspirator System. It provides an overview of the console, and a description of each major console subsystem and its components.

About the Console and Structural Features

Figure 3-1 presents the front view of the console; the components are described in Table 3-1.

Figure 3-1 Console – Front View

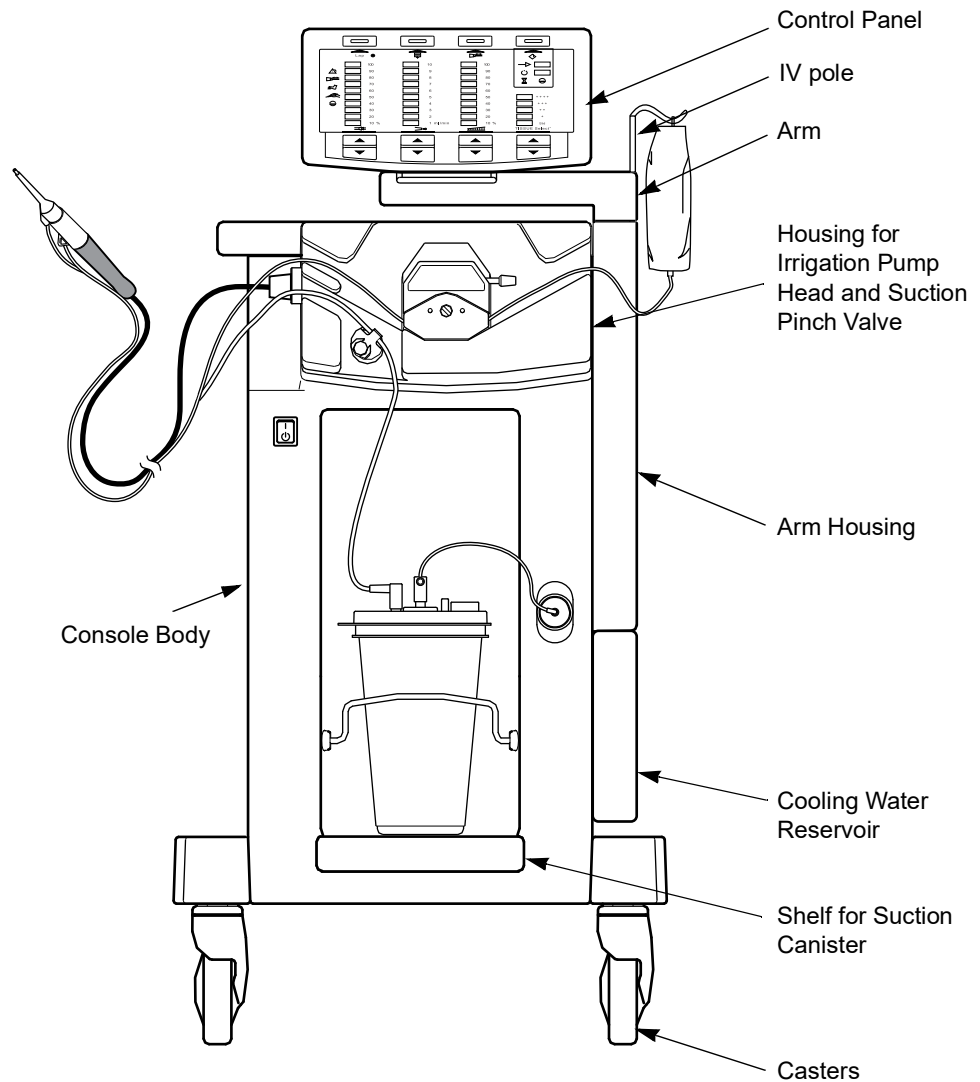

Table 3-1 Description of Console Structural Features

Component	Description
IV Pole	Supports the sterile irrigation fluid container. You can raise or lower the pole, and rotate it 90° in the lower position. The safe working load for the I.V. pole is 2 kilograms.
Control Panel	Allows the user to control all system functions. See Section 4: Control Panel Display and Functions.

Table 3-1 Description of Console Structural Features

Component	Description
Arm	<ul style="list-style-type: none"> • Supports the control panel • Pivots the control panel 135°, providing users with a view of the control panel from most of the operating room • Raises to two adjustable heights for ergonomic use
Arm Housing	Covers the arm attachment along the console body side panel.
Housing for Irrigation Pump Head and Suction Pinch Valve	Prominent black area at the top of the console body: <ul style="list-style-type: none"> • The irrigation pump head and irrigation tube pathway (marked with blue lines) • The suction pinch valve and suction tube pathway (marked with a light green line)
Console Body	Contains the electronics, pumps, and other working components.
Shelf for Suction Canister	Provides a place to put the hospital-provided suction canister.
Casters	Unlocked, both front and rear casters roll easily and rotate freely. When locked, each caster has a brake lock that stops the wheels from rolling.

Console Body – Front Panel

Figure 3-2 shows the front view of the console; the components are described in Table 3-2.

Figure 3-2 Console Body – Front Panel

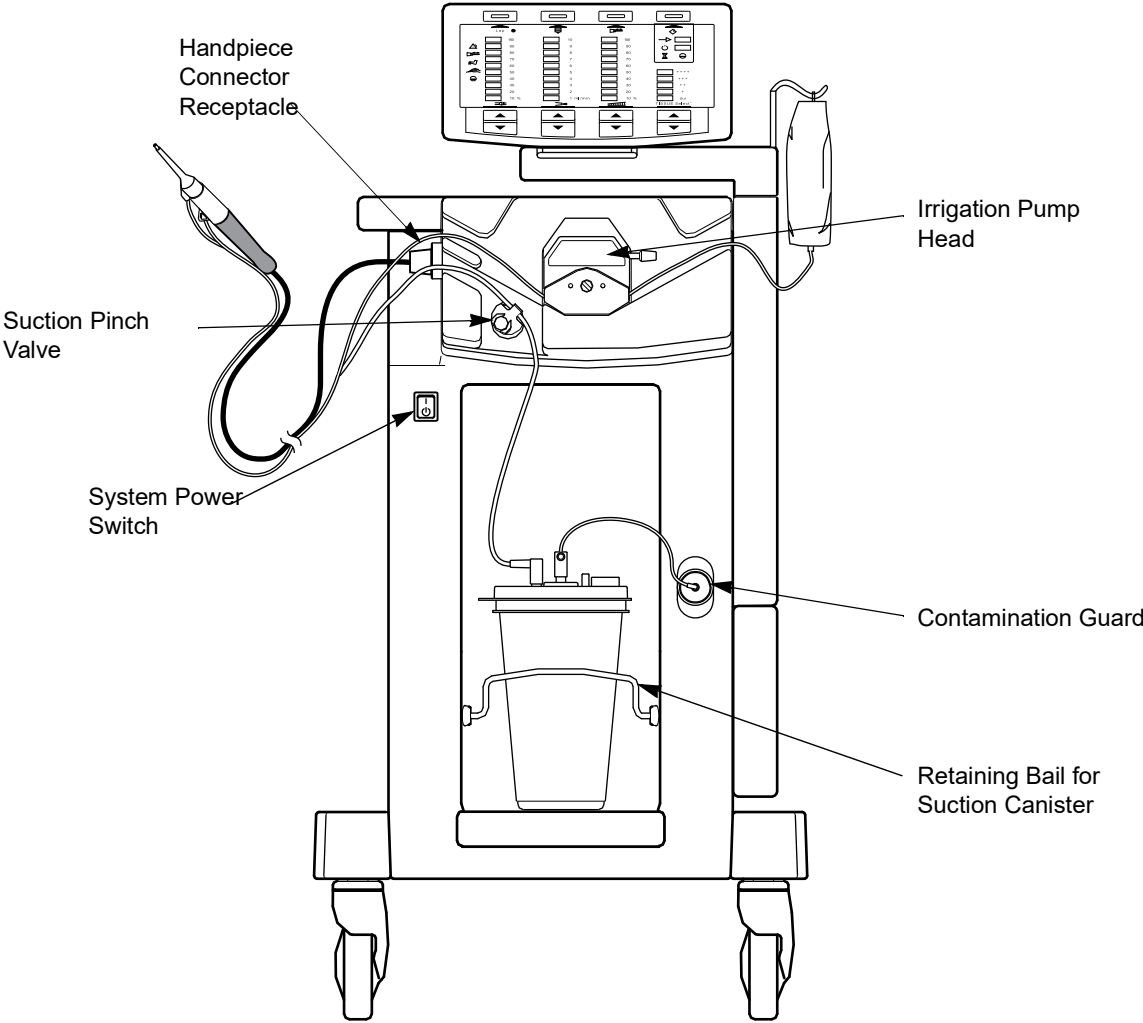

Table 3-2 Description of Console Body Components - Front Panel



Component	Description
<p>Handpiece Connector Receptacle</p> 	<p>Connects the handpiece to the console. It is on the left side of the console (as you face the front panel).</p> <p>Warning</p> <p>When you connect the handpiece to the console, the handpiece becomes a functional surgical device.</p>
<p>Suction Pinch Valve</p> 	<p>Closed, the valve pinches off suction flow to the handpiece when:</p> <ul style="list-style-type: none"> • Priming the handpiece with irrigation fluid • Pressing the Fast Flush pedal • Releasing the Vibration pedal (in LAP Mode) <p>When the System Power Switch is off, the suction pump remains off and the suction pinch valve remains closed. Use the button on the front of the suction pinch valve to open the valve.</p> <p>Warning</p> <p>To avoid injury to surgical personnel, keep fingers away from the suction pinch valve.</p>
<p>System Power Switch</p>	<p>On (): activates all system components and begins filling the handpiece with cooling water.</p> <p>Off (⏏): activates the cooling water drain cycle. When the system has drained water from the cooling water system (about one minute), it automatically deactivates all system components.</p>
<p>Irrigation Pump Head</p>	<p>Rotate the latch from right to left to open the pump head, and from left to right to close. When open, insert irrigation tubing into the peristaltic pump. When closed, the pump head holds irrigation tubing against the peristaltic pump.</p>
<p>Contamination Guard</p>	<p>Protects the vacuum pump from particulate matter and moisture in the suction stream. It is necessary to replace the contamination guard every six months or when the color changes.</p> <p>► Important</p> <p><i>The guard is hydro-philic and becomes blocked when wet.</i></p>

Table 3-2 Description of Console Body Components - Front Panel

Component	Description
Retaining Bail for Suction Canister	Holds the suction canister in place on the shelf.

Console Body – Side Panel

Figure 3-3 shows the side view of the console; the components are described in Table 3-3.

Figure 3-3 Console Body – Side Panel

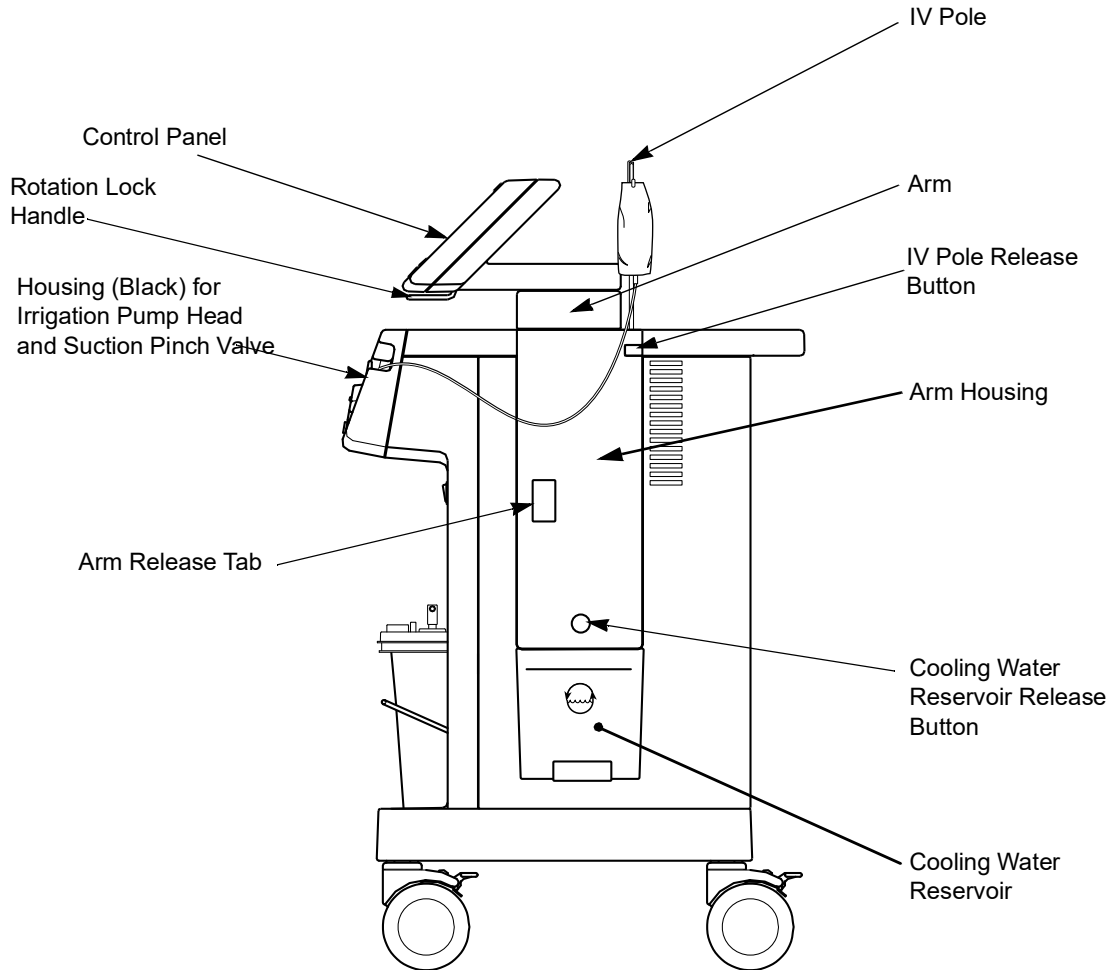

Table 3-3 Description of Console Body Components – Side Panel

Component	Description
Control Panel	See Section 4: Control Panel Display and Functions.

Table 3-3 Description of Console Body Components – Side Panel

Component	Description
Rotation Lock Handle	Releases the control panel, allowing it to swivel and lock into one of four positions: <ul style="list-style-type: none"> • Straight forward • 45° right • 45° left • 90° left
Housing for Irrigation Pump Head and Suction Pinch Valve	See Table 3-1.
IV Pole	
Arm and Arm Housing	
IV Pole Release Button	Releases the IV pole, to raise or lower it.
Arm Release Tab	Releases a lock that holds the arm in the vertical position.
Cooling Water Reservoir	Holds cooling water to be continuously circulated through the handpiece. The reservoir holds 1000 ml sterile or distilled water. A clear panel, which runs vertically up the side, shows the water level inside the reservoir. The reservoir also includes fittings that snap into receptacles inside the Arm Housing on the console side panel. The fittings and receptacles connect the reservoir to the cooling water system.

Console Body – Rear Panel

Figure 3-4 and Figure 3-5 show the rear view of the console; the components are described in Table 3-4.

Figure 3-4 Console Body – Rear Panel

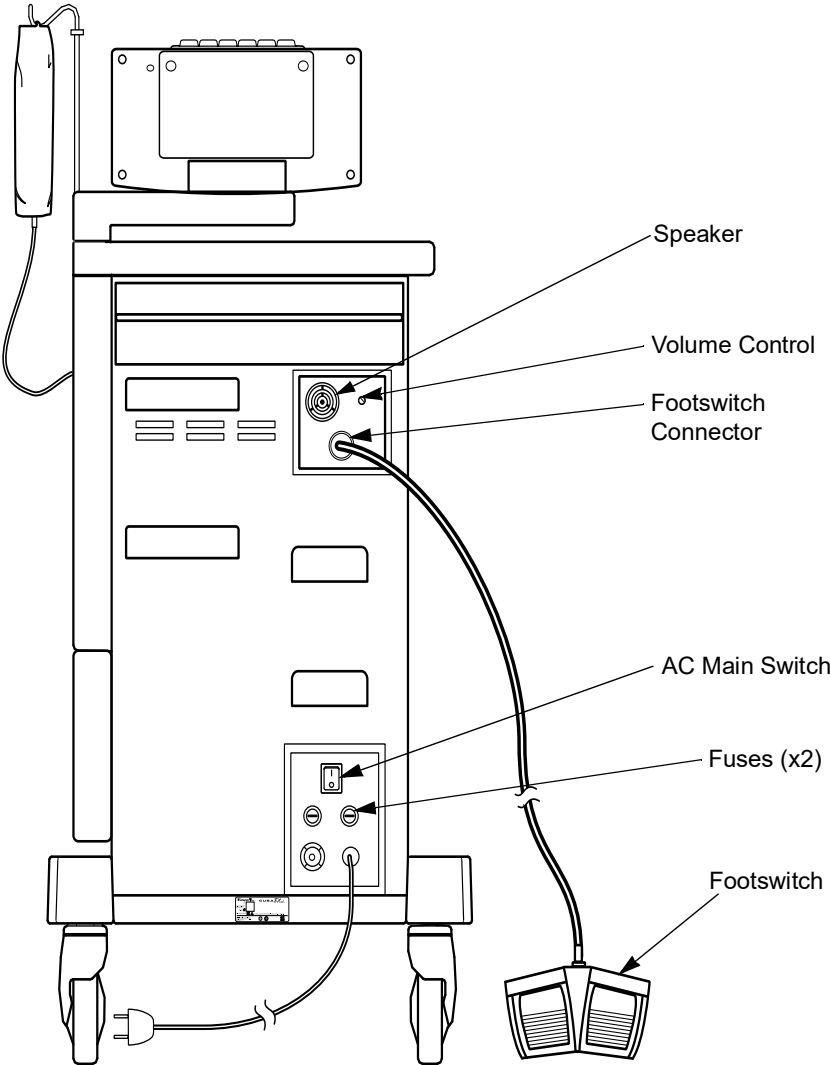

Figure 3-5 Console Body – Rear Panel Continued

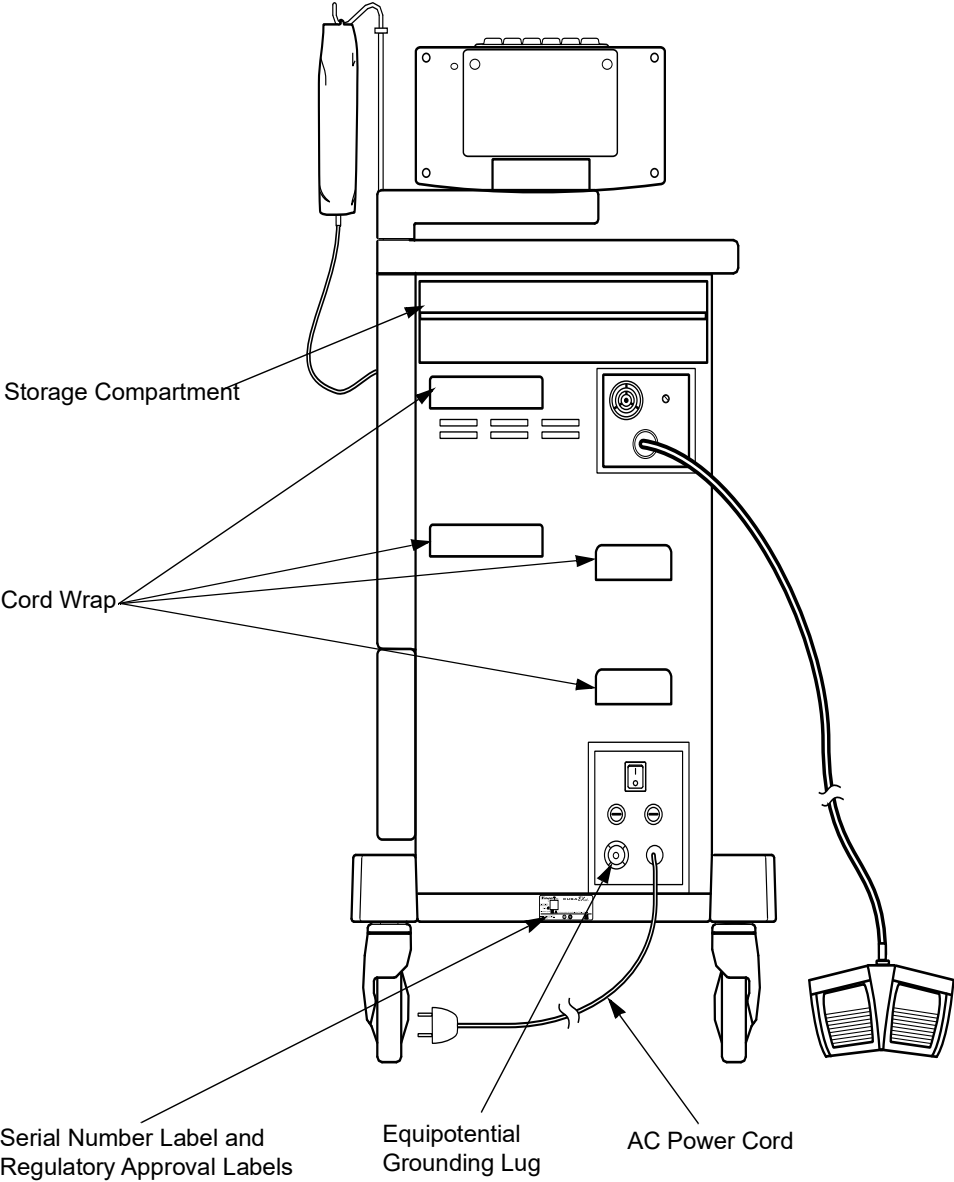

Table 3-4 Description of Console Body Components – Rear Panel



Component	Description
Speaker	Sounds an audible tone four times when an alarm condition exists, and sounds a constant tone when vibration is active.
Volume Control 	Adjusts the active vibration audible tone. You cannot adjust the alarm tone.
Footswitch Connector Receptacle 	Connects the footswitch to the console.
AC Main Switch	Controls AC power input to the system. See Section 3: About the Power Switches.
Fuses	Protect the system from electrical overloads.
Footswitch	Use the pedals on the footswitch to activate two functions: <ul style="list-style-type: none"> • Ultrasonics/vibration: Right pedal (orange), when pressed, activates vibration at the tip. When you release the pedal, vibration stops. • Fast Flush: Left pedal (blue), when pressed, increases the irrigation rate to greater than 25 ml/min. It also closes the Suction Pinch Valve, stopping suction. When you release the pedal, irrigation returns to the setpoint value and suction resumes.
AC Power Cord	Connects the system to the Mains power supply.
Equipotential Grounding Lug	Allows for the connection of a Potential Equalization Conductor that provides a connection between the equipment and the potential equalization busbar of the electrical installation (in accordance with the requirements of IEC 60601-1). This is a biomedical function.
Labels	Displays the console model number, serial number and regulatory approvals.
Cord Wrap	Use the four cord wraps to hang the cord on the back of the unit, keeping the cord safely out of the way.

Table 3-4 Description of Console Body Components – Rear Panel

Component	Description
Storage Compartment	Stores the footswitch and manual (includes one interior shelf)

About the Power Switches

The CUSA Excel/CUSA Excel+ console includes two power switches:

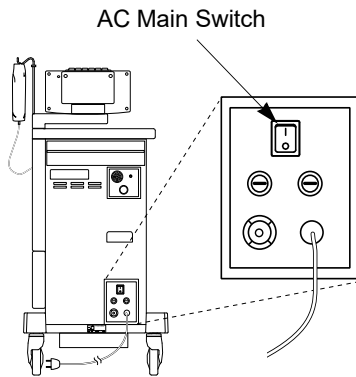

AC Main Switch

Located on the rear panel, this switch controls AC power input to the system. It does not activate the system; instead, it provides AC power to the System Power Switch (on the front panel) so that you can activate the system with the System Power Switch.

Once the AC Main Switch is on (|), you may leave it on, even when you unplug the console from the wall receptacle.

Note: To isolate the CUSA Excel/CUSA Excel+ from the AC power supply, you must unplug the console from the power source.

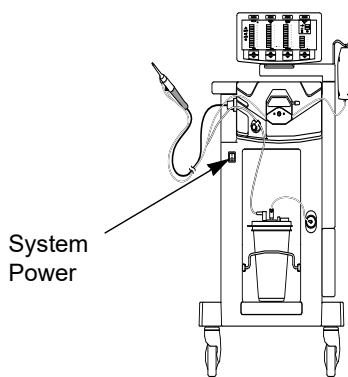

System Power Switch

Located on the front panel, this black switch activates system components, turning the CUSA Excel/CUSA Excel+ console on (|) or off/standby (⏻).

Warning

TO AVOID RISK OF ELECTRIC SHOCK, THIS EQUIPMENT MUST ONLY BE CONNECTED TO A SUPPLY MAINS WITH PROTECTIVE EARTH.

Warning

The power cord complies with the Directive EU 2015/863 amending Annex II to directive 2011/65/EU the restriction of the use of certain hazardous substances in electrical and electronic equipment (recast).

Notes

Control Panel Display and Functions

In this section:

- For Your Information, page 4-1
- About the Control Panel Display, page 4-2
- Signs and Symbols on the Excel8 and Excel9 Control Panel, page 4-10
- Signs and Symbols on the Excel and Excel 2 Control Panel, page 4-12
- Understanding the Control Panel at System Startup, page 4-13

For Your Information

This section presents the control panel for the CUSA[®] Excel/CUSA[®] Excel+ Ultrasonic Surgical Aspirator System.

The control panel can contain icons only, or icons and text, depending on the product model. The control panel for the Excel8 and Excel9 product models contains icons only. The control panel for the Excel product model contains icons and text. This chapter describes the control panel display for the different models. It also describes the control panel behavior during system startup and operation.

About the Control Panel Display

The control panel display for the Excel8 and Excel9 models (Figure 4-1), and the Excel model (Figure 4-2), are illustrated in this section. Note: The control panel display is also printed on the quick reference cards (to be fitted in a slot at the rear of the control panel).

Figure 4-1 Control Panel for Excel8 and Excel9 models

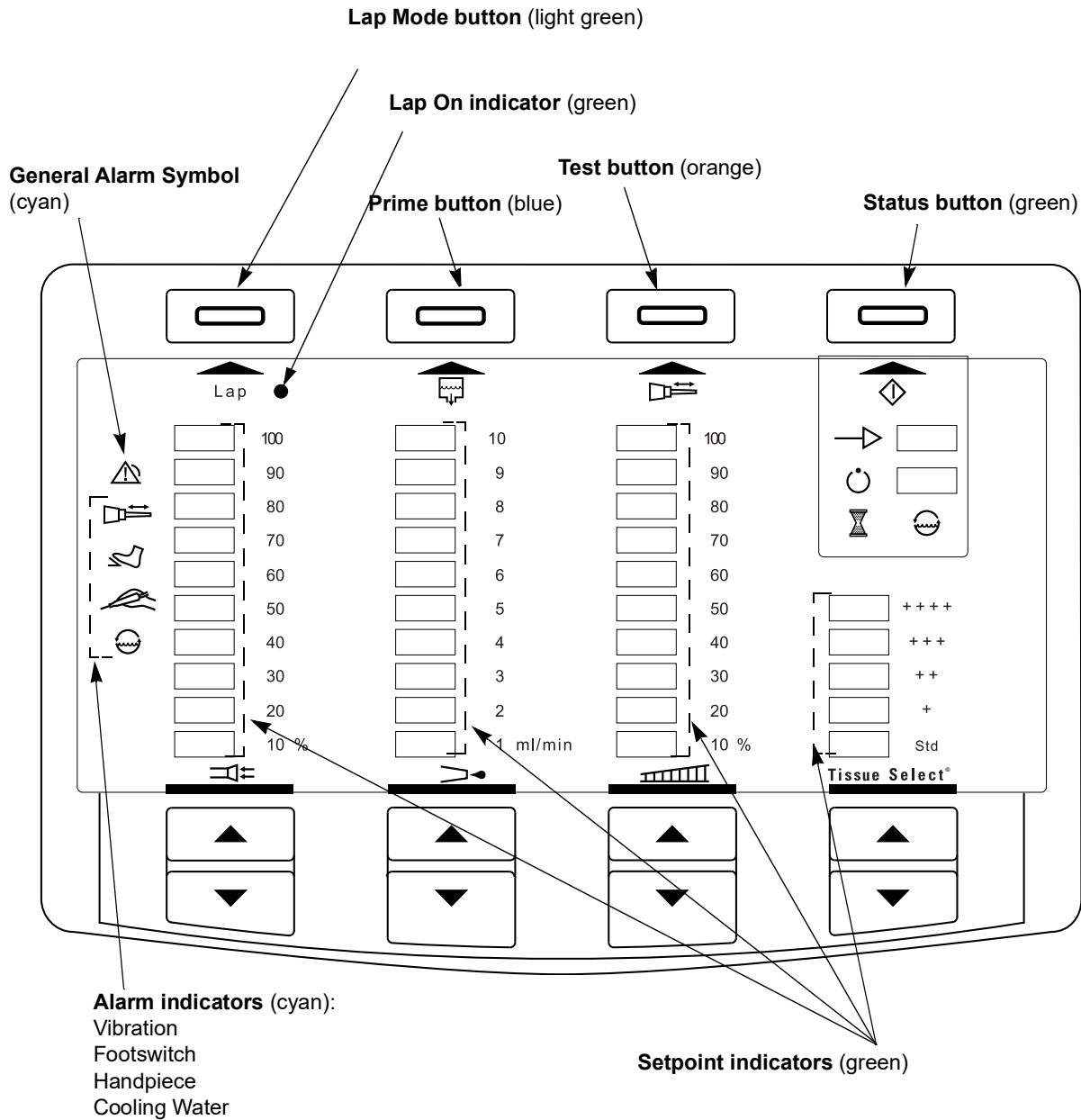
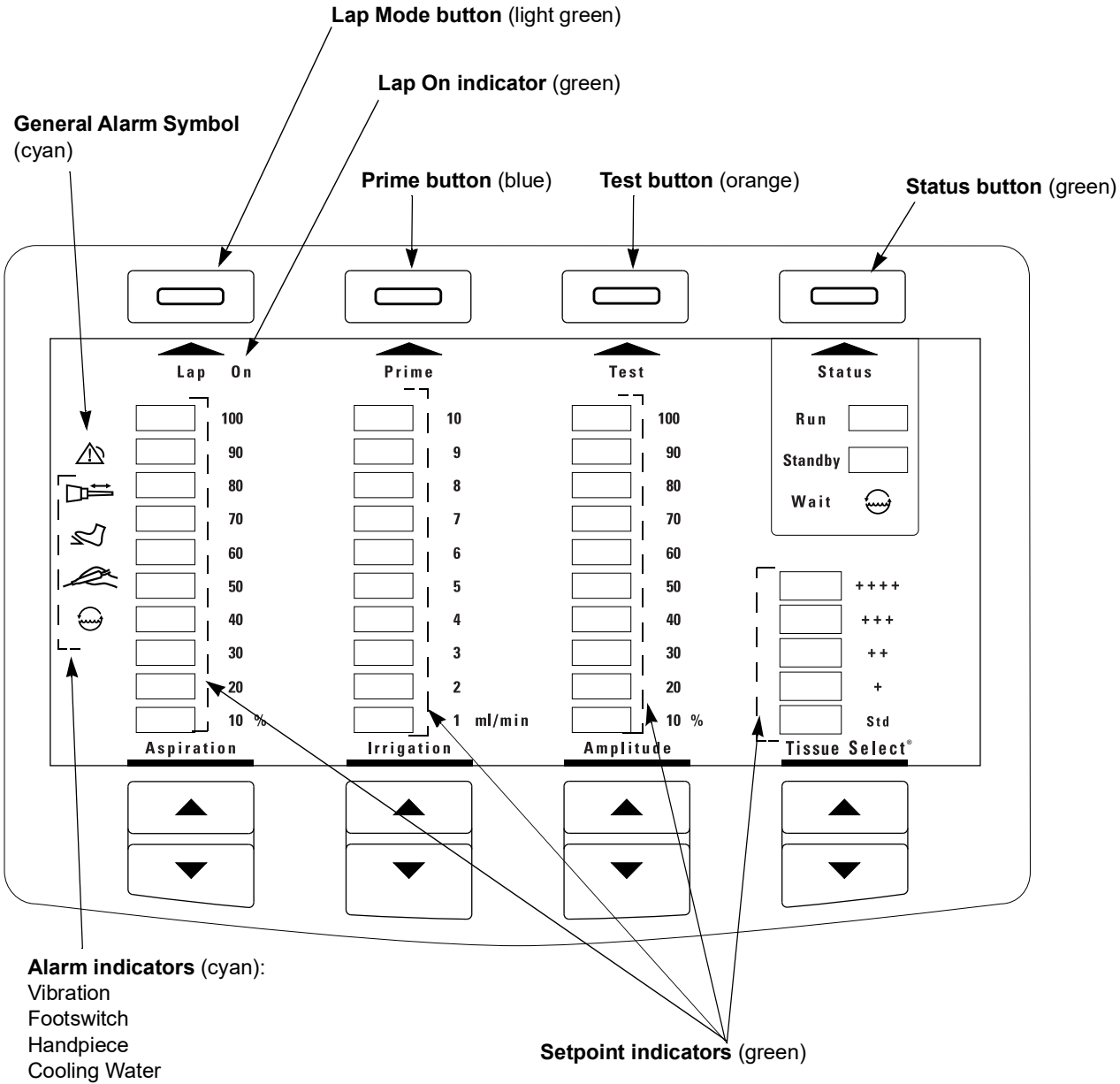

Figure 4-2 Control Panel for Excel and Excel 2 model



Alarm Indicators





The CUSA Excel/CUSA Excel+ activates an alarm to indicate a technical problem with the system. All alarms on the CUSA Excel/CUSA Excel+ are technical, low-priority alarms, for example, mechanical or equipment-related. There are no physiological alarms on the CUSA Excel System.

When the CUSA Excel/CUSA Excel+ System activates an alarm, it:

- Illuminates the general alarm symbol in cyan on the control panel. This indicates that an alarm exists on the system
- Illuminates one or more alarm indicators in cyan on the control panel. This indicates the type of alarm(s) that exist
- Sounds the alarm tone four times

Table 4-1 describes each of the alarms on the CUSA Excel/CUSA Excel+ System. The general alarm symbol and alarm indicator(s) remain illuminated until you resolve the corresponding problem(s). For information on troubleshooting alarms, see *Troubleshooting the System*, page 14-1.

Table 4-1 Description of Alarms

Alarm Indicator	Alarm	Alarm Cause	Alarm Classification	Alarm Priority
	General	Triggered when an alarm condition exists	Technical	Low
	Handpiece	Triggered when system detects that there is no Handpiece connected.	Technical	Low
	Footswitch	Triggered when system detects that there is no Footswitch connected.	Technical	Low
	Vibration	Triggered when excessive vibration at tip is detected.	Technical	Low
	Cooling Water	Triggered when issue with the cooling system is detected.	Technical	Low

See Figure 4-1 and Figure 4-2 for the location of the alarm indicators on the control panel.

There is no method to silence alarms from the control panel, therefore, to manually turn off an alarm, you must turn off the console. If the system shuts down unexpectedly (for example a power failure) with an alarm illuminated on the control panel, the alarm remains illuminated when you power the system on again. The only method of turning off the alarm indicator on the control panel is to resolve the corresponding alarm.

Recommended: When you set up the CUSA Excel/CUSA Excel+ for surgery, make sure that the control panel is always clearly visible to the surgeon in the event of an alarm. Remove any obstructions that may block the surgeon's view of the control panel.

Lap Mode, Prime, Test, and Status Buttons

To activate Lap Mode, Prime, or Status, press the button once; to deactivate the function, press the button again. To activate Test, press the button once; it automatically deactivates when the test is complete.

Lap Mode: Selects the Laparoscopic mode of operation – the system provides no suction or irrigation to the handpiece until you activate the Vibration pedal.

When you activate the Lap Mode, the system illuminates the Lap Mode indicator.

Prime: Automatically increases irrigation rate to 25 to 30 ml/min to pump irrigation fluid to the tip. A timer turns Prime off after approximately one minute.

Test: Verifies the handpiece is working properly by automatically increasing tip amplitude to 100%, then decreasing it to 0% – all within 4 seconds.

Status: Toggles the status between Standby and Run.

See Figure 4-1 and Figure 4-2 for the location of the Lap Mode, Prime, Test, and Status buttons on the control panel.

Setpoint Indicators

Green setpoint indicators show user adjusted setpoints for Aspiration, Irrigation, and Amplitude:

- Not Activated: One setpoint indicator illuminates to show the setpoint value
- Activated: All setpoint indicators up to and including the setpoint value light up.

For Tissue Select®, “Std” (standard) is the first setpoint value; “++++” is the highest setpoint value and indicates increased selectivity.

See Figure 4-1 and Figure 4-2 for the location of the setpoint indicators on the control panel.

Figure 4-3 Control Panel –
Excel8 and Excel9 model (status
indicators and setpoint
adjustment)

Status Indicators:
Run (Green)
Standby (Orange)
Wait/Cooling Water (Orange)

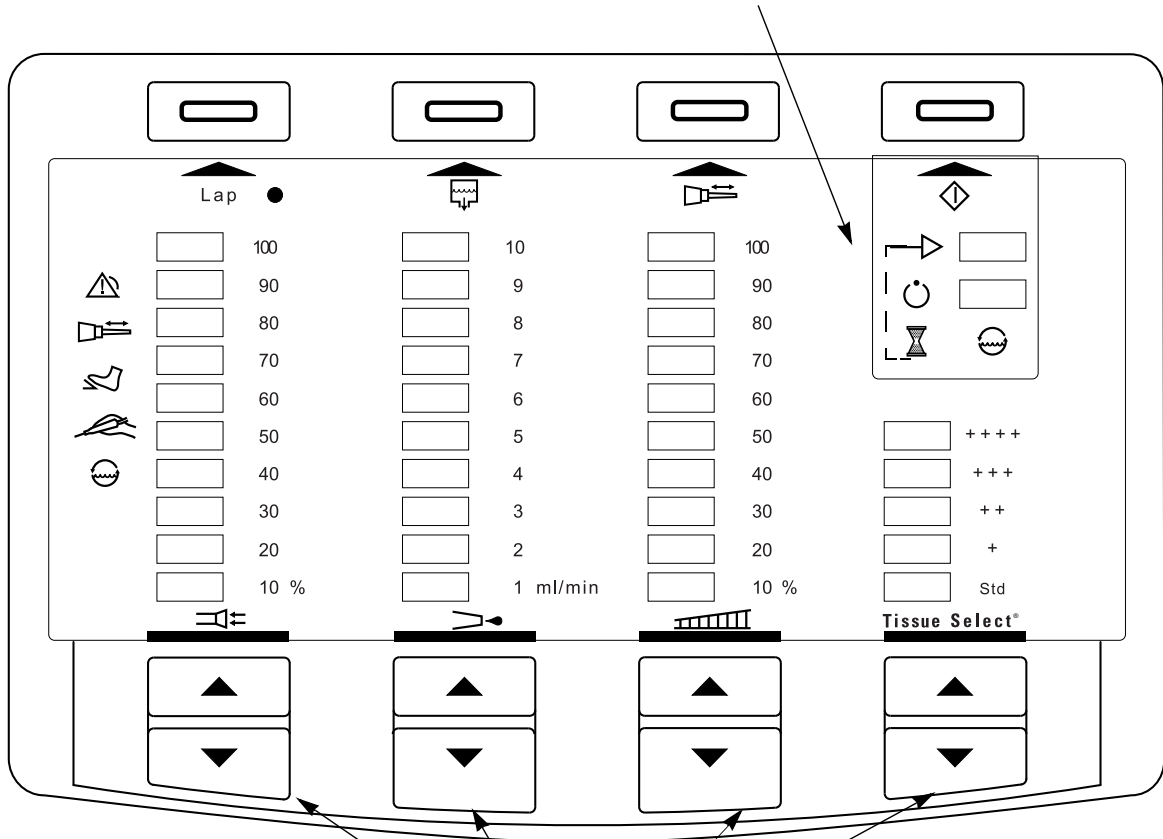

Setpoint Adjustment buttons
(Up/Down Arrows):
Aspiration (Green)
Irrigation (Blue)
Amplitude (Orange)
Tissue Select® (Yellow)

Figure 4-4 Control Panel – Excel and Excel 2 model (status indicators and setpoint adjustment)

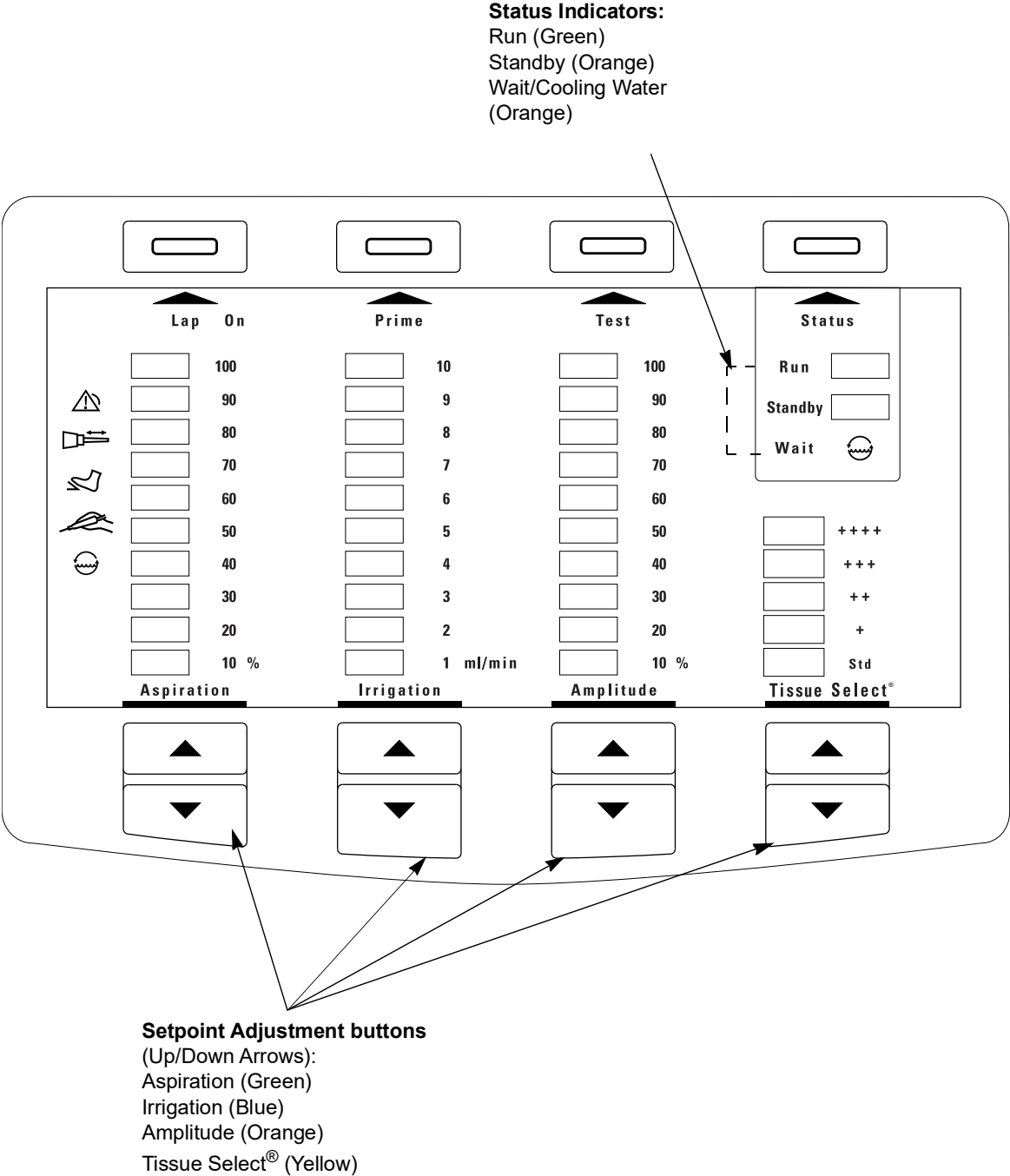

Status Indicators

To change from Standby to Run, or from Run to Standby, press the Status button.

Run: A green status indicator illuminates to show when the system is in Run status. The CUSA Excel/CUSA Excel+ must remain in Run mode for a minimum of two minutes (continuous) before it is ready for use; once the two minutes elapses, the system is ready for use.

Standby: An orange status indicator illuminates when the system is in Standby.

Wait/Cooling Water: The Wait status indicator flashes and the Cooling Water status indicator illuminates in the following circumstances:

- Immediately after turning on (|) the System Power Switch, the system automatically fills the handpiece with cooling water.
- Immediately after turning off (⏻) the System Power Switch, the system automatically drains handpiece cooling water.

While the Wait/Cooling Water status indicators remain lit, you cannot use the control panel or footswitch.

See Figure 4-3 and Figure 4-4 for the location of the status indicators on the control panel.

Setpoint Adjustment Buttons

Marked with Up/Down arrows, use these buttons to adjust the setpoint values:

- **Aspiration (Suction):** 10 increments; linear scale of 10 to 100%; default value is 100%.
- **Irrigation:** 10 increments; linear scale of 1 to 10 ml/min; default value is 3ml/min.
- **Amplitude:** 10 increments; linear scale of 10 to 100%; default value is 10%.
- **Tissue Select:** 5 increments from Std (standard operation) to +++. Tissue Select interrupts continuous vibration for specified times:

Setting	On-Time	Off-Time
Std	continuous	0 ms*
+	40 ms	10 ms
++	30 ms	10 ms
+++	20 ms	10 ms
++++	10 ms	10 ms

*1 ms = 1 millisecond = 1 one-thousandth of a second

Push a button once for a single change in setpoint value. Note: Holding down the button will only produce a single change in setpoint value.

See Figure 4-3 and Figure 4-4 for the location of the setpoint adjustment buttons on the control panel.

Signs and Symbols on the Excel8 and Excel9 Control Panel

Table 4-2 lists each symbol and its meaning. You can find this symbol list on the quick reference guide (to be fitted at the top of the control panel).

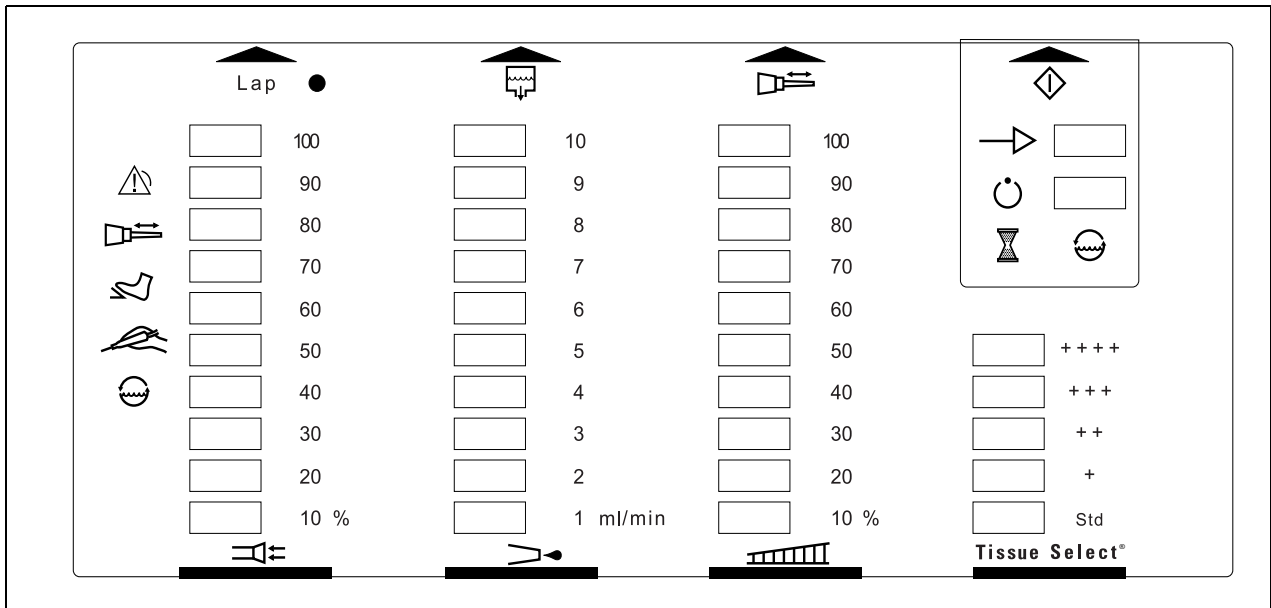

Table 4-2 Signs and Symbols on the Excel8 and Excel9 Control Panel















Symbol	Description
	General alarm symbol: Indicates that an alarm condition exists (cyan, left side of panel).
	Vibration alarm: Vibration failure/The handpiece is not working properly (cyan, left side of panel).
	Test (orange, top of amplitude display): System in Test mode.
	Footswitch alarm: Footswitch failure or footswitch connector not plugged into its receptacle on the console rear panel (cyan, left side of panel).
	Handpiece alarm: Handpiece failure or handpiece connector not plugged into its receptacle on the console (cyan, left side of panel).
	Cooling Water alarm: Cooling water problem in the system (cyan, left side of the control panel).
	Wait (orange, right side of the control panel): System is circulating cooling water through the handpiece or draining the handpiece

Table 4-2 Signs and Symbols on the Excel8 and Excel9 Control Panel

Symbol	Description
	Suction adjust
	Irrigation adjust
	Amplitude adjust
Std	Standard
	Standby
	Run
	Start action/change status
	Prime
Lap ●	Laparoscopic Mode is On/Selected (green, top left of control panel)

Signs and Symbols on the Excel and Excel 2 Control Panel

Table 4-3 lists each symbol and its meaning. You can find this symbol list on the quick reference guide (to be fitted at the top of the control panel).











	Lap On	Prime	Test	Status
	<input type="checkbox"/> 100	<input type="checkbox"/> 10	<input type="checkbox"/> 100	Run <input type="checkbox"/>
	<input type="checkbox"/> 90	<input type="checkbox"/> 9	<input type="checkbox"/> 90	Standby <input type="checkbox"/>
	<input type="checkbox"/> 80	<input type="checkbox"/> 8	<input type="checkbox"/> 80	Wait 
	<input type="checkbox"/> 70	<input type="checkbox"/> 7	<input type="checkbox"/> 70	
	<input type="checkbox"/> 60	<input type="checkbox"/> 6	<input type="checkbox"/> 60	
	<input type="checkbox"/> 50	<input type="checkbox"/> 5	<input type="checkbox"/> 50	<input type="checkbox"/> ++++
	<input type="checkbox"/> 40	<input type="checkbox"/> 4	<input type="checkbox"/> 40	<input type="checkbox"/> +++
	<input type="checkbox"/> 30	<input type="checkbox"/> 3	<input type="checkbox"/> 30	<input type="checkbox"/> ++
	<input type="checkbox"/> 20	<input type="checkbox"/> 2	<input type="checkbox"/> 20	<input type="checkbox"/> +
	<input type="checkbox"/> 10 %	<input type="checkbox"/> 1 ml/min	<input type="checkbox"/> 10 %	<input type="checkbox"/> Std
Aspiration		Irrigation	Amplitude	Tissue Select®

Table 4-3 Signs and Symbols on the Excel and Excel 2 Control Panel

Symbol	Description
	General alarm symbol: Indicates that an alarm condition exists (cyan, left side of panel).
	Vibration alarm: Vibration failure/The handpiece is not working properly (cyan, left side of panel).
 FOOTSWITCH	Footswitch alarm: Footswitch failure or footswitch connector not plugged into its receptacle on the console rear panel (cyan, left side of panel).
 HANDPIECE	Handpiece alarm: Handpiece failure or handpiece connector not plugged into its receptacle on the console (cyan, left side of panel).
	Cooling Water alarm: Cooling water problem in the system (cyan, left side of the control panel).
Lap On	Laparoscopic Mode is On/Selected (green, top left of control panel)

Understanding the Control Panel at System Startup

When you turn on (|) the System Power Switch, it activates the CUSA Excel/CUSA Excel+ System components. This section presents the control panel features in the order in which you will encounter them as you set up, test, and use the system.

Note: The Excel8 and Excel9 control panel illustration is shown for reference only.

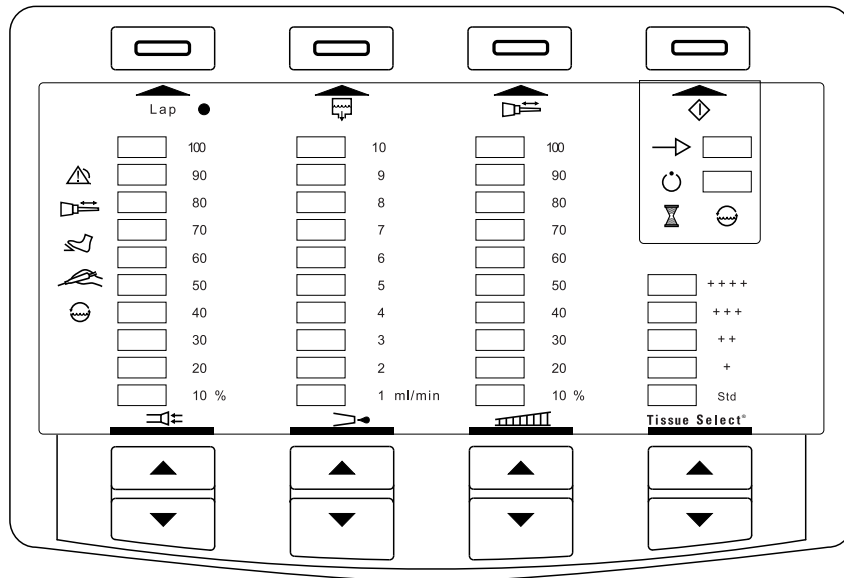

When you turn on (|) the System Power Switch (on the front panel), the CUSA Excel/CUSA Excel+ System illuminates all indicators on the control panel, including the alarm indicators, for approximately four seconds; then it turns off all indicators.

The CUSA Excel/CUSA Excel+ System then checks for the footswitch and the handpiece connections. If the system detects the footswitch and handpiece, the Wait (flashing) and the Cooling Water (solid) status indicators turn on. After one minute, the Wait and Cooling Water status indicators turn off. The Test and Prime indicators then turn on. If the system cannot detect either the handpiece or footswitch connections, it activates the appropriate alarm.



Footswitch Alarm

When turned on (|), if the system does not find the footswitch connection, it illuminates the general alarm symbol and the Footswitch alarm indicator, and it sounds the alarm tone four times. Then it turns off the Wait status indicator. If this occurs, make sure the footswitch is connected to the console rear panel. If not, connect it. The Footswitch alarm will turn off and the Wait status indicator will turn on.



Handpiece Alarm

When turned on (|), if the system does not find the handpiece connection, it illuminates the general alarm symbol and the Handpiece alarm indicator, and it sounds the alarm tone four times. Then it turns off the Wait status indicator. If this occurs, make sure the handpiece is connected to the console. If not, connect it. The Handpiece alarm will turn off and the Wait status indicator will turn on.

Note: When turned off (⏻), the system automatically drains the cooling water from the handpiece and the cooling water system; the Wait status indicator and Cooling Water status indicator illuminate. Do not disconnect the handpiece while the system is draining cooling water. If you do, the system illuminates the Handpiece alarm and turns off the Wait status indicator. If this happens, reconnect the handpiece to the console. The system turns the Wait status indicator on and the alarm off, and resumes draining the cooling water. When the system completes draining the cooling water, the entire control panel turns off (goes blank). Then you can disconnect the handpiece.

System startup will not proceed until you clear a handpiece or footswitch alarm. If you connect the handpiece and footswitch and the corresponding alarm indicator remains on, call Integra for assistance.

Wait



Wait/Cooling Water



When the system detects that the handpiece and footswitch are connected, it automatically begins to circulate cooling water through the handpiece. This takes about one minute to complete. While the system performs this task, the orange Wait status indicator flashes and the orange Cooling Water status indicator (upper right on the control panel) illuminates.

When the Wait and Cooling Water status indicators are illuminated, you cannot use the control panel. When the system turns off the Wait and Cooling Water status indicators, it turns on the suction pump, the Test status indicator, and the Prime status indicator.



Cooling Water Alarm

If the system detects a cooling water problem, it illuminates the general alarm, symbol and the Cooling Water alarm indicator (left side of the control panel), and it sounds the alarm tone four times. Possible causes for this alarm are:

- No water in the cooling water reservoir
- Disconnected cooling water reservoir
- Damaged, misaligned, or missing o-rings in the handpiece connector
- Pinched or kinked handpiece cable
- Air leak in the cooling water system

To correct these conditions:

- Add water

- Connect the reservoir
- Remove the pinch or kink
- For an air leak in the handpiece tubing, or an o-ring problem in the handpiece connector, connect a new handpiece

While the Cooling Water alarm indicator remains illuminated, you cannot use the control panel or footswitch.

Warning

Ignoring alarms on the CUSA Excel/CUSA Excel+ System while continuing to use the system may result in injury to the patient and/or surgical personnel, or equipment damage.

Test Test

Use the Test button (orange box on a black button) at the top of the Amplitude display to test the handpiece function.

To test the handpiece, press the Test button. The system automatically activates the handpiece at 100% vibration for 4 seconds. During the test, green setpoint indicators in the amplitude display light up to 100% to show that the handpiece is working correctly.

If the setpoint indicators do not light up to 100%, a problem may exist. To troubleshoot:

- Push the Test button again
- Verify proper tip torquing
- If the problem persists, perform more complete troubleshooting (see Section 14: Troubleshooting the System)

Vibration Alarm

If the handpiece is not working properly, the system illuminates the general alarm symbol and the Vibration alarm (left side of the control panel), and it sounds the alarm tone four times. Possible causes for this alarm are:

- Damaged tip
- Loose tip (not properly attached to handpiece)

Prime Prime

To start Prime, press the Prime button (blue box on a black button at the top of the Irrigation display). You need to repeat Prime until you see irrigation fluid flow at the handpiece tip. If it doesn't, verify that all connections are tight, then press the Prime button again.

The Prime button automatically increases the rate of the irrigation pump to 25 to 30 milliliters per minute (ml/min). Prime allows the system to pump irrigation fluid through the manifold tubing, through the flue, and onto the tip as quickly as possible, reducing setup time. Watch for irrigation fluid

dripping from the handpiece tip. Priming takes about one minute. As the system primes, one setpoint indicator in the Irrigation display illuminates every 6 seconds to show its progress.

To stop Prime at any time, press the Prime button again.

You can repeat the Prime process at any time by pressing the Prime button once to start Prime, and pressing it again to stop Prime.

After priming, the system automatically proceeds to Standby status.

Standby



Standby Status

When the system enters the Standby status, it illuminates the orange Standby status indicator (upper right on the panel). It automatically sets the following default values:

Aspiration	100%
Irrigation	3 ml/min
Amplitude	10%
Tissue Select	Std

Before using the CUSA Excel/CUSA Excel+ System at the surgical site, adjust setpoint values, then select Laparoscopic mode (if desired) and Run status.

Setting Up the System

In this section:

- For Your Information, page 5-1
- Quick Reference – Setup, page 5-2
- Handpiece Assembly Options, page 5-3
- Preparing the System for Startup, page 5-4
- Turning On the System, page 5-7
- Connecting the Suction Tubing, page 5-7
- Connecting the Irrigation Tubing, page 5-9
- Testing the Handpiece, page 5-11
- Testing the Alarm Tone, page 5-12
- When the Surgeon Is Ready, page 5-13

For Your Information

This section describes how to set up the CUSA[®] Excel/CUSA[®] Excel+ Ultrasonic Surgical Aspirator System for surgery, starting with the arrival of the sterilized handpiece and accessories to the operating room, and ending with the system in Run mode ready for the surgeon's use.

The CUSA Excel/CUSA Excel+ System requires a minimum of one hour exposure at its operating temperature range before you use it. Make sure that the system is located in the surgical room at least an hour before use.

Quick Reference – Setup

Use this list if you are a knowledgeable user who needs only a reminder of the steps to set up the CUSA Excel/CUSA Excel+ System.

Handpiece Assembly

1. Attach the tip to the handpiece.
2. Assemble the o-rings to the tip.
3. Attach the standard nosecone onto the handpiece.
4. Attach the flue.
5. Attach the sterile manifold tubing (if not attached before sterilization).
6. Attach the aspiration and irrigation tubing at the handpiece.

Console Assembly

1. Plug the power cord into a wall receptacle.
2. Confirm that the AC Main Switch located on the rear panel is on.
3. Confirm that the footswitch is plugged into its receptacle.
4. Spike an irrigation bag (Lactate Ringer's or normal saline) with large drip IV administration set, and hang it at the side of the console.
5. Fill the cooling water reservoir with distilled water, then slide it into place. Do not use tap water or saline solution.
6. Connect the suction canister to the console at the contamination guard.
7. Connect a sterile handpiece to the system.
8. Turn on (|) the System Power Switch located on the front panel.
9. Connect the suction manifold tubing to the console and the suction canister.
10. Connect the irrigation manifold tubing to the console and the IV administration set. Open the IV clamp.
11. Wait until the Wait (flashing) and Cooling Water status indicators go off.
12. Press the Test button to check the setup of the handpiece. If the cyan vibration alarm indicator does not illuminate, the handpiece is functioning properly.
13. Press the Prime button to prime the handpiece with sterile irrigation fluid.
14. Adjust settings for amplitude, suction, and irrigation.
15. Press the Status button to select the Run mode when the surgeon is ready to use the system. The CUSA Excel/CUSA Excel+ System must remain in Run mode for a minimum of two minutes (continuous) before it is ready for use; once the two minutes elapses, the system is ready for use.

Handpiece Assembly Options

If you want to:**Do this:**

Assemble the tip to the handpiece in a nonsterile area before sterilization

Go to:

- ▶ *Section 8, Assembling the Handpiece in a Nonsterile Area*
- ▶ *Section 9, Sterilizing Handpieces and Accessories*
- ▶ *Section 10, Completing Handpiece Setup in the Sterile Field*

Assemble the tip to the handpiece in the sterile field

Go to:

- ▶ *Section 11, Assembling or Changing Tips in the Sterile Field.*

You also have the option of attaching manifold tubing to the handpiece cable before or after handpiece sterilization. If you chose to attach the manifold tubing after handpiece sterilization, you must attach it in the sterile field, see *Section 10: Completing Handpiece Setup in the Sterile Field*.

Preparing the System for Startup

At the Rear Panel

1. Plug the CUSA Excel/CUSA Excel+System power cord into a wall receptacle.
2. Confirm that the AC Main Switch on the rear panel is on (|).
3. Verify that the system footswitch is connected to the rear of the console.
4. Follow hospital policies and procedures regarding the placement of footswitches into plastic bags.

On the Side Panel: Filling the Cooling Water

1. Remove the cooling water reservoir from the console:
 - a. Press the button (just above the reservoir) on the Arm Housing to release the latch inside the housing.
 - b. Slide the reservoir toward the rear of the console, then remove it from its slot.
2. Gently open the black rubber lid on the reservoir top.
3. Fill the cooling water reservoir to the line with 1000 ml distilled water (sterile water is distilled).



Warning

Do not fill the Cooling Water reservoir with tap water or saline solution. Use distilled water only.

4. Gently close the black rubber lid.
5. Slide the cooling water reservoir into the slot on the console side panel until it snaps into place.

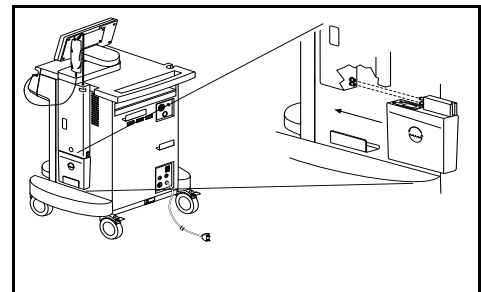

On the Front Panel: Suction

Notice

To prevent fluid flowing into the vacuum line, only use a suction canister that has a non-return valve.

1. If used, install the specimen trap into the hospital-provided suction canister.
2. Put the suction canister on the shelf in the front of the console.

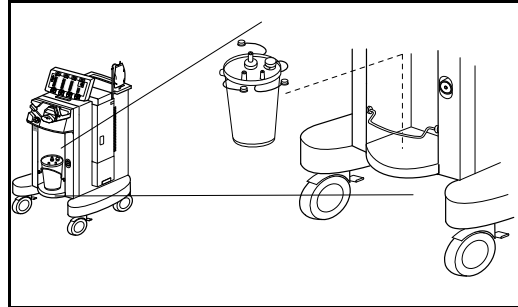

3. Verify that the contamination guard is in place in the console.

Note: We recommend you retain a second contamination guard in the surgical environment in case the guard becomes blocked.

4. Attach the green L-shaped connector from the contamination guard to the VACUUM port on the suction canister lid.

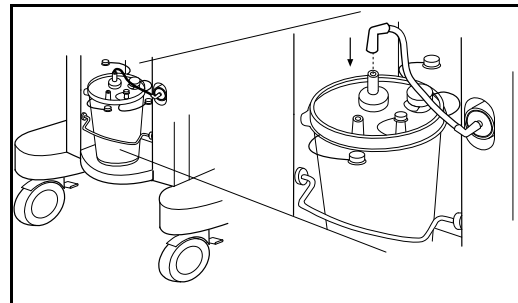

5. Secure the canister with the retaining bail.

On the Front Panel: Handpiece

1. Connect the handpiece to the console.



Warning

When you connect the handpiece to the console, the handpiece becomes a functional surgical device.

Caution

Sharp edge at the handpiece connection point.

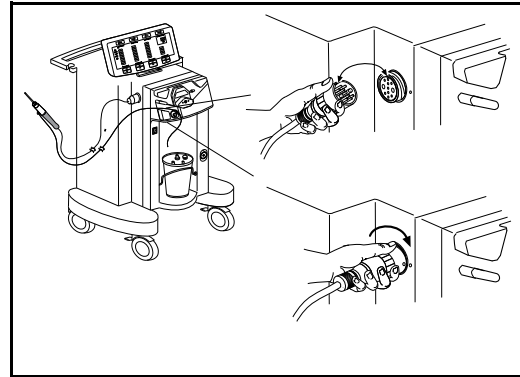

- a. Line up the notch on the handpiece connector to the key in the receptacle (at the 12 o'clock position).

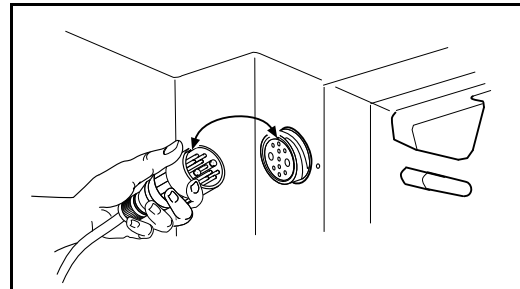

- b. Gently push the handpiece connector onto the console connector.
- c. Turn the connecting ring in the clockwise direction until the yellow dot on the handpiece aligns with the yellow dot on the console.

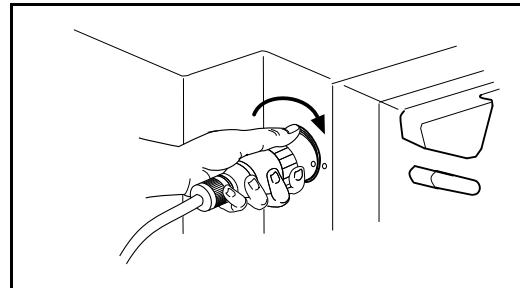

Turning On the System

1. Turn on (|) the black System Power Switch (located on the front panel) to activate the system.
2. Verify that all indicators on the control panel (including the alarm indicators) illuminate for four seconds approximately, and then turn off again.

Note: This step verifies that all indicators, including the alarm indicators, are functioning correctly.

3. Verify that the Wait (flashing) and the Cooling Water status indicators are on.

When active, the system draws distilled water through the handpiece cooling system. This takes about one minute, during which time the Wait (flashing) and Cooling Water status indicators illuminate. When the system successfully fills the cooling system with water, it turns the Wait and Cooling Water status indicators off.

4. While you wait for the Wait and Cooling Water status indicators to go off, connect the manifold suction tubing to the console (next section).

Connecting the Suction Tubing



Warning

To avoid injury to surgical personnel, keep fingers away from the suction pinch valve.

1. Align the green band on the manifold suction tubing with the green line on the front of the console.
2. Above the green band, hold the suction tubing with one hand; with the other hand, stretch the tubing into the suction pinch valve.

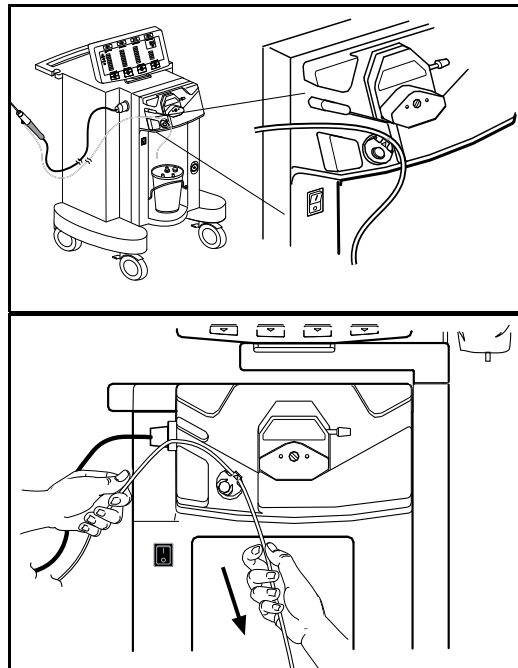

3. Connect the green L-shaped connector on the suction tube to the PATIENT port on the suction canister lid.
4. Make sure all unused ports on the suction canister lid are closed, and the canister lid is tightly sealed to the canister.

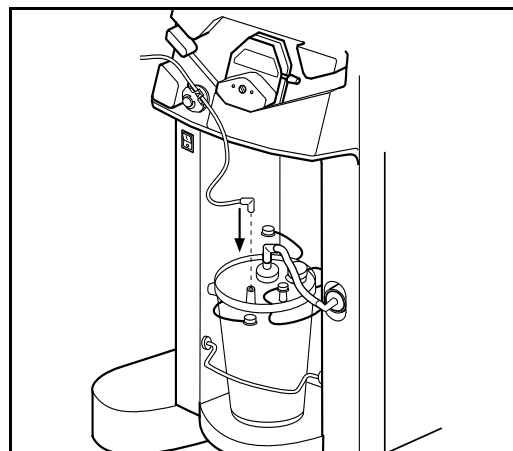

The following figure shows the suction system as it looks after successful setup.

Figure 5-1 The assembled suction system

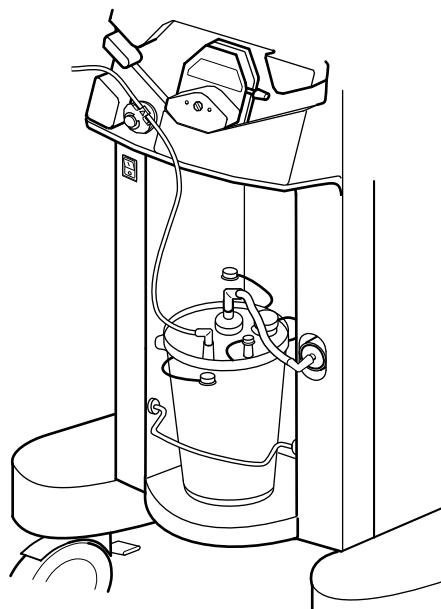

Connecting the Irrigation Tubing



Warning

To avoid injury to surgical personnel:

- When closing the irrigation pump latch, keep fingers away from the area between the V-shaped tubing retainers.
- If the pump latch is open, keep fingers away from the pump rollers.

1. Prepare a standard IV administration set and sterile irrigation solution, and put it on the IV pole located next to the adjustable arm.
2. Connect the irrigation tubing (from the handpiece) to the CUSA Excel/CUSA Excel+ System.

- a. To open the pump latch (if it is not already open), rotate the lever to the left.

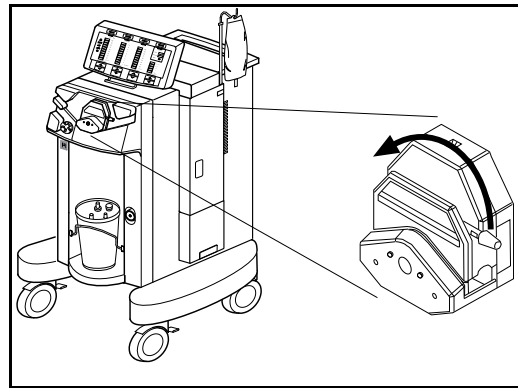

- b. Align the blue stripe on the irrigation tube with the blue line on the front of the console, then center the irrigation tubing inside the pump rollers, between the V-shaped tubing retainers.

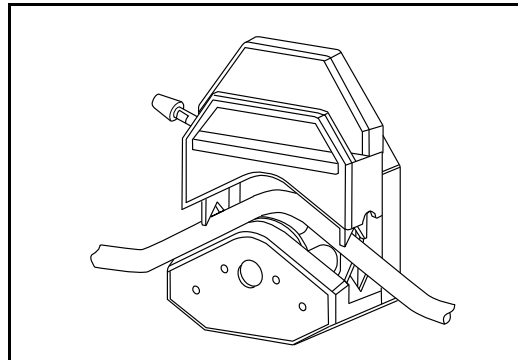

Caution

Make sure that the irrigation tubing centers between the V-shaped tubing retainers before you close the pump latch. Otherwise, the pump latch will pinch the tubing, preventing the flow of irrigation fluid.

- c. To close the pump latch, rotate the lever to the right.
3. Remove the cap from the irrigation tubing.
4. Connect the irrigation tubing to the IV administration set tubing.
5. Make sure that the person assembling the handpiece has connected the irrigation tubing to the handpiece flue.
6. Open the roller clamp on the IV tubing.

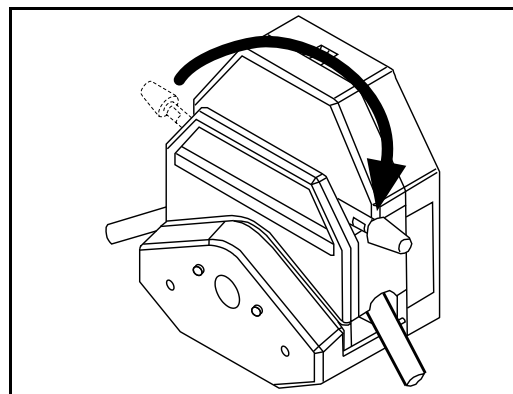

The following figure shows the irrigation system as it looks after successful setup.

Figure 5-2 The assembled irrigation system

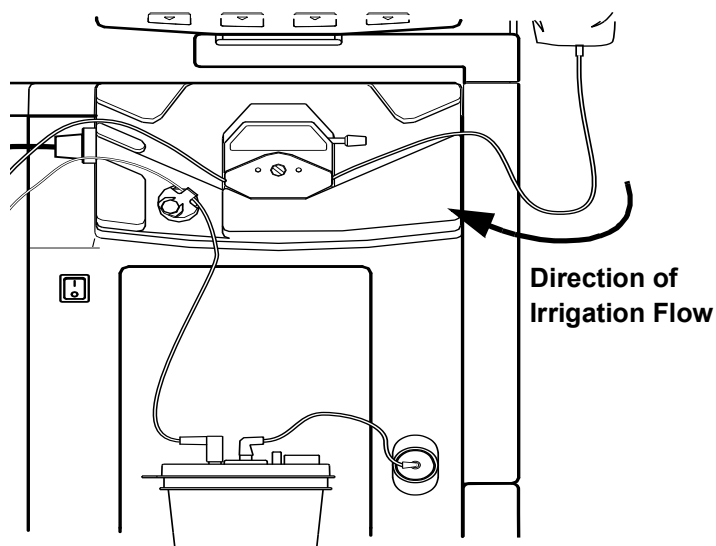

Testing the Handpiece

Warning

Do not use a damaged handpiece with the CUSA Excel/CUSA Excel+ System. This may result in injury to the patient or surgical personnel.

Warning

When the handpiece is connected to a CUSA Excel/CUSA Excel+ System that is powered on, but the handpiece is not in use, keep the handpiece away from the patient. Place the handpiece on a sterile, flat, dry, nonconductive, and highly visible surface.



Warning

When you connect the handpiece to the console, the handpiece becomes a functional surgical device.

Caution

When you test the handpiece, do not allow the handpiece tip to contact anyone or anything during tip activation. Contact may result in patient injury, user injury, or handpiece tip damage.

When the handpiece cooling water system fills, the system automatically proceeds to the next step and illuminates the Test and Prime setpoint indicators.

1. Press the Test button (orange box on a black button at the top of the amplitude display panel) on the control panel.

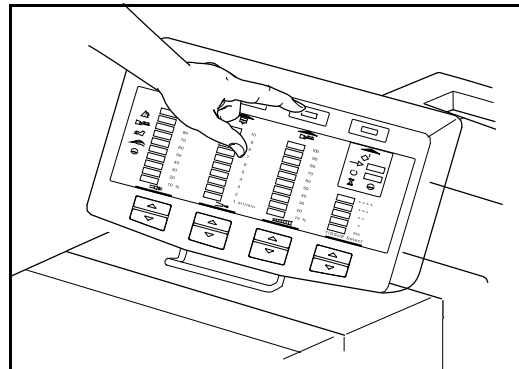

The system automatically activates the handpiece at 100% vibration for 4 seconds. During the test, green setpoint indicators in the amplitude display light up to 100% to show that the handpiece is working correctly.

2. Verify the following:
 - ▶ *The Vibration alarm (cyan) is off.*
 - ▶ *The setpoint indicators light up to 100%.*

If no Vibration alarm illuminates, and if the setpoint indicators light up to 100%, the handpiece is working properly. Continue with the system setup.

If the Vibration alarm illuminates, or if the setpoint indicators do not light up to 100%, the handpiece is not working properly. This usually results from an improperly attached tip. To troubleshoot:

- ▶ *Verify proper tip torquing*
- ▶ *Push the Test button again*
- ▶ *If the problem persists, perform more complete troubleshooting (see Section 14: Troubleshooting the System)*

Testing the Alarm Tone

To verify the alarm tone functions correctly, you must intentionally trigger an alarm on the CUSA Excel/CUSA Excel+ System, for example, disconnect the footswitch from console:

1. Disconnect the footswitch from the console at the footswitch connector (rear panel).
2. The footswitch alarm triggers on the system.
3. Verify that the system sounds the alarm tone four times.

If the alarm tone doesn't sound, contact your Integra representative.

When the Surgeon Is Ready

Warning

Ignoring alarms on the CUSA Excel/CUSA Excel+ System while continuing to use the system may result in injury to the patient and/or surgical personnel, or equipment damage.

Warning

The handpiece and handpiece accessories must be sterile before surgical use.

Caution

During surgery, under maximum loading conditions, the CUSA Excel/CUSA Excel+ console is suitable for ultrasonics activation times of 10 minutes on, 5 minutes off.

1. Make sure the IV administration set roller clamp is open.

2. Prime the irrigation system:

a. Press the Prime button.

The CUSA Excel/CUSA Excel+ System automatically primes the irrigation system. Setpoint indicators move from 0 to 10 ml on the irrigation display column. This will take about 1 minute.

b. Make sure irrigation fluid drips from the tip.

If it doesn't, verify that all connections are tight, then press the Prime button again.

If fluid appears at the top of the tip before priming is complete, stop the priming cycle by pressing the Prime button again.

When irrigation prime is complete, the system automatically goes to Standby mode; it illuminates the orange Standby status indicator and displays the default setpoint indicator levels for the Aspiration, Irrigation, Amplitude, and Tissue Select[®] settings

Aspiration	100%
Irrigation	3 ml/min
Amplitude	10%
Tissue Select	Std

For more information on these settings, see Section 6: Using the Console Controls.

3. Adjust the Amplitude, Irrigation, Aspiration, and Tissue Select settings to the surgeon's requirements.

4. Press the Status button to put the system into the Run mode (green light).

The CUSA Excel/CUSA Excel+ System must remain in Run mode for a minimum of two minutes (continuous) before it is ready for use; once the two minutes elapse, the system is ready for use. Vibration will activate when the surgeon presses the Vibration pedal on the footswitch.

5. Position the footswitch where it is easily accessible to the surgeon.
6. Position the CUSA Excel/CUSA Excel+ System so that the control panel is clearly visible to the surgeon at all times. Remove any obstructions that may block the surgeon's view of the control panel.

To move the console in the operating room, push it by the handle only. For guidelines on moving the console within your Healthcare Facility, see Handling and Transporting of the System, page 15-4.

Caution

Before surgery, apply the brakes locks to all wheels on the console to stop the wheels from rolling.

Notice

During surgery, do not allow the handpiece tip to touch metal objects such as staples, clips, instruments, etc. Handpiece tip damage will result.

Warnings Relating to Tip Usage During Surgery

Warning

Touching of the tip of the handpiece by the operator, while the handpiece is powered on, can result in personal injury.

Warning

When the handpiece is powered on, contact of the tip with a hard surface (e.g. a metal instrument, tray, staples, clips, instruments, etc) may damage the tip of the handpiece and require replacement before use.

Warning

CUSA Excel tips utilize silicone flues. Compressing the flue against the side of the vibrating surface along the length of the tip can cause excessive heating and potential hazard to adjacent tissue, such as burns.

Warning

Excessive loading of CUSA Excel tips at the surgical site can induce heating due to vibration and acoustic power transmissions. Thermal management of the surgical site with the aid of the appropriate irrigation and aspiration settings is essential.

Warning

Avoid excessive lateral loading of CUSA Excel tips.

Warning

Avoid contacting bone with the CUSA Excel tips (excluding SaberTip™).

Notes

Using the Console Controls

In this section:

- For Your Information, page 6-1
- Adjusting Setpoint Values, page 6-1
- Changing Functions, page 6-3
- Using the Tissue Select Feature, page 6-4
- Using Other Features, page 6-6

For Your Information

This section describes how to use the buttons and indicators on the control panel. It also describes how to use some of the mechanical features on the CUSA[®] Excel/CUSA[®] Excel+ Ultrasonic Surgical Aspirator System console.

Adjusting Setpoint Values

Press the up/down buttons at the bottom of the display to adjust the setpoint value. Green setpoint indicators illuminate to show the adjusted setpoint value indicating that the system is ready for use at that value. You can adjust setpoint values when the:

- System is in Standby status
- System is in Run status
- Surgeon presses the Vibration footswitch pedal

Aspiration  **Aspiration**

The aspiration display includes 10 settings, ranging from 10 to 100% of available suction (up to 660 mm mercury at sea level). The default setting is 100%. Green up/down arrows mark the aspiration adjustment buttons.

Irrigation  **Irrigation**

The irrigation display includes 10 settings. The irrigation rate ranges from 1 ml/min to 10 ml/min. The default setting is 3 ml/min. Blue up/down arrows mark the irrigation adjustment buttons.

Amplitude  **Amplitude**

The amplitude display includes 10 settings, from 10 to 100% of the total amplitude (distance traveled by the tip as it vibrates) available for the handpiece. The default setting is 10%. Most surgical procedures require a higher setting. Orange up/down arrows mark the amplitude adjustment buttons.

The setpoint indicators in the amplitude display show real-time feedback from the system about the tip performance. The number of setpoint indicators lit shows the tip performance at any given time.

The Tissue Select[®] Feature

This display includes 5 settings, ranging from Std to +++. These settings indicate the tissue selectivity at the handpiece tip. The highest setting (++++) makes the tip most selective. The default setting is Std (Standard). For more information on the Tissue Select[®] feature and its settings, see Using the Tissue Select Feature, page 6-4. Yellow up/down arrows mark the Tissue Select adjustment buttons.

Changing Functions

When starting the CUSA Excel/CUSA Excel+ System, switch to Run status by pressing the green Status button.

Run Run Status

To select the Run status, press the Status button. The system changes from Standby to Run, turning off the orange status indicator for Standby and turning on the green status indicator for Run.

The CUSA Excel/CUSA Excel+ System must remain in Run mode for a minimum of two minutes (continuous) before it is ready for use; once the two minutes elapse, the system is ready for use. Note that this is applicable each time the system changes from Standby to Run mode.

To activate the handpiece, press the Vibration (right) pedal on the footswitch. The tip vibrates. To stop vibration, release the pedal.

Lap On Laparoscopic Mode

In the laparoscopic (Lap) mode, the system provides suction and irrigation only when it provides vibration. When the surgeon activates vibration by stepping on the footswitch, the system opens the suction pinch valve. When the surgeon releases the footswitch, the system stops vibration, closes the suction pinch valve, and stops irrigation. This feature reduces the potential for evacuating the pneumoperitoneum.

To select the laparoscopic mode, press the Lap button. The system lights the Lap indicator (green status indicator below the Lap button).

To turn off the laparoscopic mode, press the Lap button again.

Fast Flush

Fast Flush increases irrigation rate from the setpoint value to greater than 25 ml/min to allow additional irrigation at the surgical site. When the surgeon activates Fast Flush, the system illuminates all setpoint indicators in the Irrigation display to show the higher rate. When the surgeon releases the pedal, the system returns the setpoint indicator display to the setpoint value.

To activate Fast Flush, press the Fast Flush (left) pedal on the footswitch.

To stop Fast Flush, release the pedal.

Quiet Function

When the surgeon has not pressed either footswitch pedal for at least four minutes, the system changes to a Quiet Function. In the Quiet Function, the irrigation and suction pumps run at reduced speed and the machine is quieter.

As soon as the surgeon presses either pedal, or the operator presses a control panel button, the system returns to normal operation.

Using the Tissue Select Feature

The Tissue Select feature increases both the inherent selectivity and the tactile feedback of the vibrating tip by reducing the reserve power the ultrasonic generator provides to the handpiece.

One of the variables of power consumption is time: reduce time, reduce power consumed. To reduce power consumption, the ultrasonic generator reduces the time that it provides electrical power. Specifically, rather than providing power continuously, it provides power at measured on-off intervals:

Setting	Fragmentation Rate
Std	Maximum power
+	Slightly decreased tissue removal rate, increased tissue selectivity and tactile feedback
++ and +++	Further decreased tissue removal rate, increased tissue selectivity and tactile feedback
++++	slowest tissue removal rate, maximum selectivity and tactile feedback

Power decreases as on-time decreases.

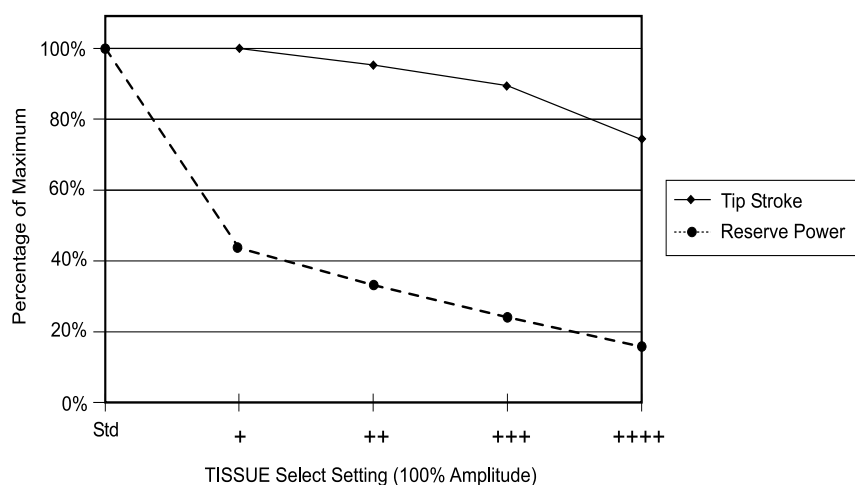

At a 100% Amplitude setting, as Tissue Select settings increase, on-time and reserve power decrease.

The Tissue Select feature offers five settings from “std” (standard – least selective) to +++++ (most selective). The std setting selects continuous power, resulting in ample reserve power. The +++++ setting selects the least power.

Standard Operation

Power is continuous. The ultrasonic generator provides ample reserve power; more than is necessary to drive stroke amplitude under heavy load:

- The tip fragments “soft” tissue easily.
- The tip fragments “strong” tissue, but with more difficulty (slower, requires more surgeon pressure).

Tissue Select Operation

Power is interrupted. The ultrasonic generator provides less reserve power to the handpiece:

- The tip still fragments “soft” tissue easily.
- But, when it encounters “strong” tissue, the power the tip receives is no longer enough to fragment the tissue. The tip stalls.

At increased selectivity settings (+ to +++++), suction and the tip cross-sectional area remain the same, and stroke amplitude and tip acceleration decrease slightly:

Setting	Fragmentation Rate	On-Time	Off-Time
Std	Maximum tissue removal rate	Continuous	0 ms*
+ (Cavitation 1)	Slightly decreased tissue removal rate, increased tissue selectivity and tactile feedback	40 ms	10 ms
++ (Cavitation 2)	Further decreased tissue removal rate, increased tissue selectivity and tactile feedback	30 ms	10 ms
+++ (Cavitation 3)	Slow tissue removal rate, maximum selectivity and tactile feedback	20 ms	10 ms

Setting	Fragmentation Rate	On-Time	Off-Time
++++ (Cavitation 4)	Slowest tissue removal rate, maximum selectivity and tactile feedback	10 ms	10 ms

*1 ms = 1 millisecond = 1 one-thousandth of a second

Note: The Tissue Select performance specifications are ± 10% of setting.

Using Other Features

The CUSA Excel/CUSA Excel+ console offers other convenient features:

- Adjustable arm height
- Rotating control panel
- Adjustable audible tone (excluding the alarm tone)
- Adjustable IV pole

The next portion of this section describes how to use these features.

Raising/Lowering the Arm

It is possible to raise the arm that supports the control panel to improve ergonomics or to see the control panel more easily over obstacles. A locking mechanism holds the arm at one of three positions: normal (lowest position), 7.6 cm (2.992 in) above normal, and 15.2 cm (5.984 in) above normal.

To adjust the arm position:

1. With one hand, press the release tab (rectangular) on the arm housing to disengage the lock. Once you disengage the lock and begin to move the arm, it is not necessary to continue pressing the button.
2. With the other hand, grasp the arm and push gently up or down. A counterweight balances the arm, making it easy to raise or lower.
3. Continue to move the arm up or down until it reaches the next position at which the lock engages. You will feel and hear the arm click into place in the locked position.
4. To move the arm to another position, press the release tab again and continue to gently move the arm.

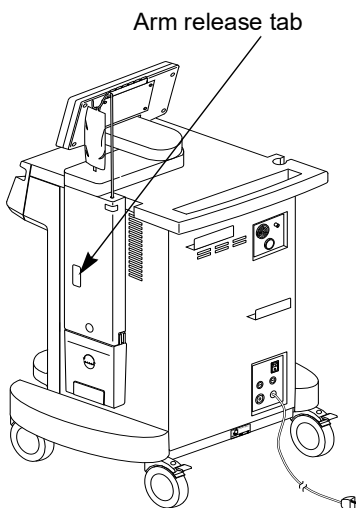

Rotating the Control Panel

The control panel rotates and locks into one of four positions:

- Straight forward
- 45° right
- 45° left
- 90° left

To rotate the control panel from one position to another:

1. Grasp the release handle located under the control panel, and pull the handle toward the front of the console.
2. While holding the handle in this position, rotate the control panel out of its previous position, then release the handle.
3. Continue to rotate the control panel. At its next locking position, it will automatically lock into place.

Adjusting the Tone Volume

The CUSA Excel/CUSA Excel+ System includes an audible tone that sounds in two circumstances:

- When you press the Ultrasonics pedal on the footswitch to activate tip vibration
- When an alarm activates

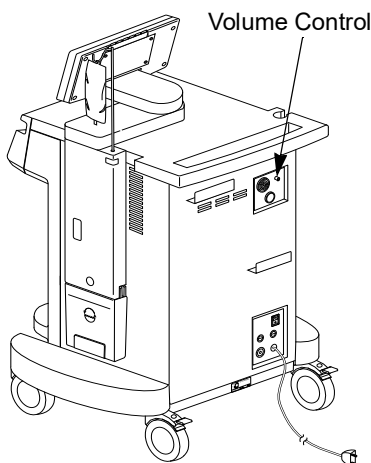

Ultrasonics Tone

This tone (constant) sounds when you press the Ultrasonics pedal on the footswitch. You can adjust its volume.

To adjust tone volume, rotate the stem on the volume control potentiometer located just above and to the right of the footswitch connector receptacle on the console rear panel:

- Volume up – clockwise
- Volume down – counterclockwise

Note: At its lowest volume, the ultrasonics tone is barely audible. You cannot turn off the ultrasonics tone.

Alarm Tone

This tone (on/off) sounds when an alarm activates. You cannot adjust the volume of the alarm tones. The alarm tone is less than 80dB.

Adjusting the IV Pole

The IV pole, located at the top rear of the arm housing, adjusts to two locking positions: down or up. A spring-loaded locking pin slides into a recessed area on the pole to serve as a lock on the pole's up/down motion. A button, located just under the opening in which the pole rests in the arm housing, releases the locking pin.

When in the down position, the pole also rotates approximately 90° allowing two positions:

- Parallel to the console side (position A)
- At a right angle to the side (position B).

When in the up position, the pole does not rotate. It remains at position B. Notice that the IV bag does not hang over the console.

When the unit is shipped, the IV pole is in position A.

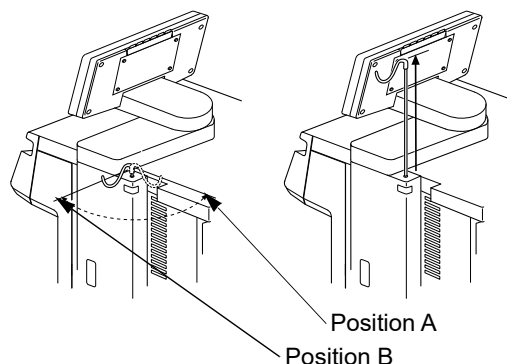

Raise the Pole

To raise the IV pole:

► **Important**

Do not try to raise the pole from Position A. Do not try to rotate the pole when it is in the upper position.

1. Grasp the pole and rotate it to position B.
2. With one hand, hold the pole; with the other hand, press the button to release the locking pin.
3. Raise the pole. As the pole clears its lower locking position, release the button.
4. Continue to move the pole upward until it locks into position.

Lower the Pole

To lower the IV pole:

5. With one hand, hold the pole; with the other hand, press the button to release the locking pin.
6. Gently lower the pole. As the pole clears its upper locking position, release the button.
7. Continue to move the pole downward until it locks into position.
8. After the pole has locked into its lower position, you can rotate it to position A.

Handpiece Components

In this section:

- For Your Information, page 7-1
- Components of Assembled Handpieces, page 7-2
- Additional Handpiece Components, page 7-5

For Your Information

This section presents the items that compose an assembled handpiece for the CUSA[®] Excel/CUSA[®] Excel+ Ultrasonic Surgical Aspirator System, their physical characteristics, and functions.

This section also presents items that, although not a part of the handpiece itself, are essential in assembling a handpiece or preparing it for sterilization.

Components of Assembled Handpieces

The following figure shows the items that comprise a handpiece.

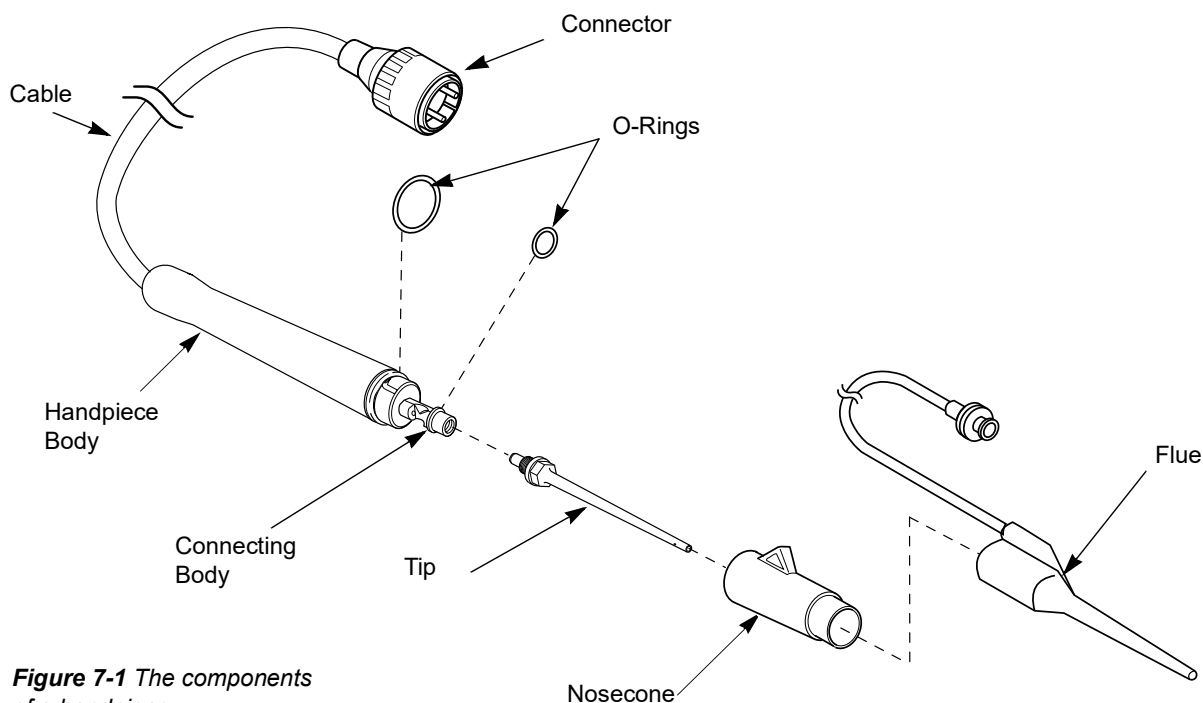

Figure 7-1 The components of a handpiece

Handpiece

The handpiece consists of a connector, a cable, a handpiece body, and a connecting body (see Figure 7-1). The connector attaches the cable to the CUSA Excel/CUSA Excel+ console. The cable contains:

- Cooling water tubes (deliver water from the console to cool the handpiece)
- Electric wires (deliver electric power from console to drive the handpiece)

The handpiece body contains these working items:

- An electric coil, which creates a magnetic field that excites the transducer
- A transducer, which converts electric energy to mechanical motion
- Cooling water tubes; the water removes the heat generated by the transducer in the energy conversion

The connecting body serves as the connecting point for the tip and transfers the vibrations from the transducer to the tip.

Remember:

- The 23 kHz handpieces are gray with green connectors

- The 36 kHz handpiece is black with a blue connector

O-Rings

The o-rings fit onto the connecting body in two places:

- A large o-ring fits into a groove on the handpiece housing neck
- A smaller o-ring fits into a groove near the tip end of the connecting body

The o-rings provide stability for the nosecone and prevent fluid leaks into the connecting body.

Use different colored o-rings for different frequency handpieces:

	23 kHz	36 kHz
Large o-ring	black	white
Small o-ring	green	blue

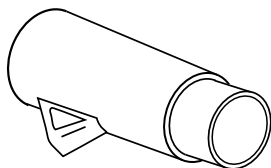

Standard Nosecone

Nosecone

The nosecone attaches to the handpiece and covers the connecting body. The standard nosecone is nonsterile and reusable. It serves two purposes:

- Holds the flue in place
- Anchors the suction tube

Tip

The tip, a hollow titanium tube, touches patient tissue. When active, the tip vibrates at an ultrasonic frequency, causing it to fragment tissue.

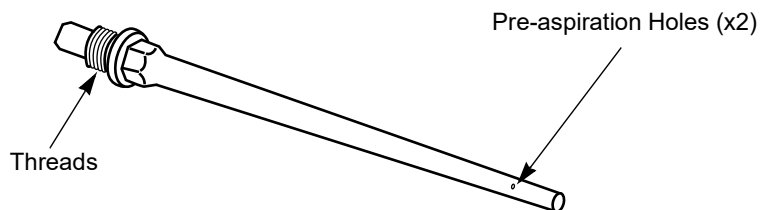

The tip has two patented pre-aspiration holes, one on either side, which help to keep the tip clear and provide better visibility at the surgical site.

Threads on one end allow you to attach the tip to the connecting body on the handpiece.

For more information on various tip diameters and lengths, see Appendix A, *Technical Specifications*, in this guide.

Flue

The flue (see Figure 7-1), a translucent silicone tube tapered at one end, provides a sleeve over the tip. Irrigation fluid flows through an irrigation connection tube at one end of the flue and down the tip to the surgical site.

Each tip size requires a tip-specific flue; therefore, you will find the tip-specific flue packaged with the appropriate tip.

Manifold Tubing

The manifold tubing (silicone) consists of two tubes:

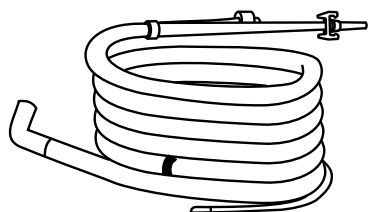

- Suction tubing – one end (with a light green fitting) connects to a suction canister on the console and passes through the suction pinch valve; the other end connects to the suction port on the handpiece nosecone.
- Irrigation tubing – one end connects to a standard IV set at the console and passes through the irrigation pump; the other end connects to the flue.

The manifold tubing set also includes clips (not shown) that attach the manifold tubing to the handpiece cable.

Manifold tubing is sterile, single patient use only. You can resterilize unused manifold tubing once. You have two options for attaching the tubing to the handpiece:

- Attach the manifold tubing before sterilization
- Attach the manifold tubing in the sterile field

Whether you attach the manifold tubing before or after sterilization, discard the tubing after one use.

Notice

Attach manifold tubing only if the handpiece is to be sterilized with manifold tubing at 132°C (270°F). If handpieces are to be sterilized at 134°C (273°F), assembly of manifold tubing should be done in the sterile field. Refer to Sterilization Parameters, page 9-1.

Warning

Single Use devices are for single patient use only. Do not reprocess or re-use. Devices (s) is (are) intended to be used for one procedure only. If reprocessed or re-used may result in the infection of patient (or patient specimen) through cross-contamination, as well as would incur the risk of modifying the properties and performance of the device, and of increasing the likelihood of complications and/or undesirable effects. Once used, devices must be disposed of in accordance with hospital policies.

Additional Handpiece Components

This section presents components that are essential in assembling a handpiece or preparing it for sterilization.

Nonsterile Tip Torquing Base and Torque Wrench

Use this set only if you are changing tips in the nonsterile field.

The tip torquing base holds the handpiece securely in place while you use the torque wrench to attach or remove a tip. The base contains a slot for each handpiece.

The double-headed wrench provides tip torquing and tip removal. The opening at one end fits 23 kHz tips; at the other end, 36 kHz tips.

Figure 7-2 Tip torquing base and torque wrench for use when changing tips in the nonsterile field

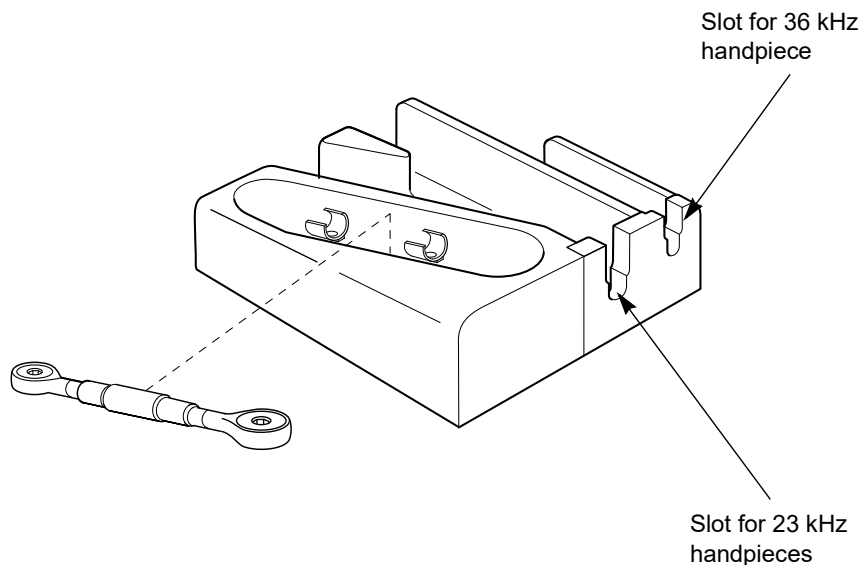

Color coding in the tip torquing base slots, on the ends of the torque wrench, and on each handpiece connector makes it easy to determine where to put the handpiece in the base and which end of the torque wrench to use when attaching a tip to a handpiece.

23 kHz	green
36 kHz	blue

Notice

Do not sterilize the tip torquing base or the torque wrench with steam. Steam destroys the lubrication in the torquing mechanism, resulting in product damage.

Sterilizable Torque Bases

Use sterilizable torque bases if you are changing tips in the sterile field.

The sterilizable torque bases hold the handpiece securely in place while you use a torque wrench to attach or remove a tip. Two bases are available:

- 23 kHz – This base contains two slots, one for the straight handpiece and one for the angled handpiece.
- 36 kHz - This base contains a single slot for the handpiece.

Figure 7-3 The sterilizable torque bases for use when changing tips in the sterile field

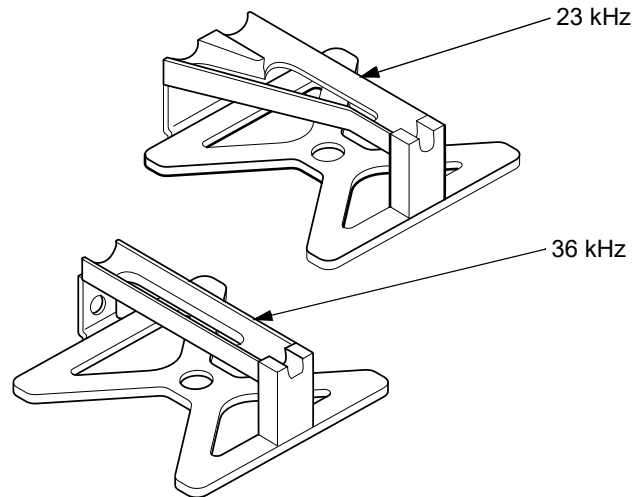

Sterilize the torque bases with steam. To hold the torque bases in position in the sterilizer case, install the restraining devices in the sterilizer case. These restraining devices comprise of pegs that snap into the tray and silicone straps that hold the bases to the pegs, and they are packaged with the torque bases.

Sterile Torque Wrenches

Use a sterile torque wrench if you are changing tips in the sterile field.

The sterile wrenches provide tip torquing and tip removal. You can use one sterile wrench to remove and re-install as many as five tips in one surgical procedure.

Warning

Do not use the sterile wrench for more than one surgical procedure.

Two sterile wrenches are available: 23 kHz and 36 kHz.

Figure 7-4 The sterile torque wrench for use when changing tips in the sterile field

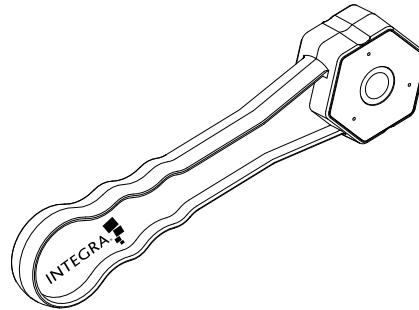

Sterilizable torque bases and sterile wrenches bear the same color coding as other CUSA Excel/CUSA Excel+ System components:

23 kHz	green
36 kHz	blue

Sterilizer Cases

The sterilizer cases hold the handpiece and accessories during sterilization.

There are separate sterilizer cases for each handpiece: 23 kHz (gray case) and 36 kHz (white case). The dimensions for both cases are:

- length – 54.6 cm (21.5 in.)
- width – 25.4 cm (10 in.)
- depth – 12.7 cm (5 in.)

The sterilizer case may be wrapped in hospital approved materials.

Figure 7-5 The 23 kHz
CUSA Excel/CUSA Excel+
handpiece sterilizer case

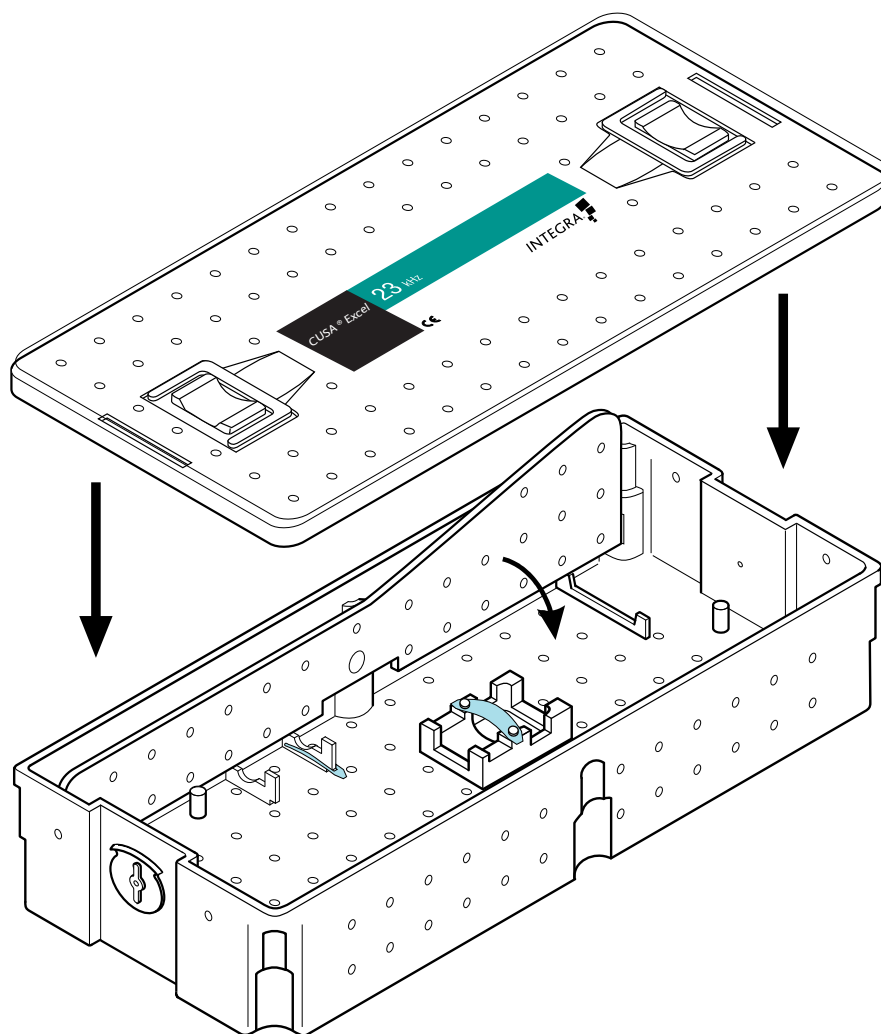

Assembling the Handpiece in a Nonsterile Area

In this section:

- For Your Information, page 8-1
- Items Needed for Handpiece Assembly, page 8-3
- Attaching the Tip to the Connecting Body, page 8-5
- Putting On the O-Rings, page 8-6
- Clipping the Manifold Tubing to the Handpiece Cable (Optional), page 8-7
- Packaging the Handpiece for Sterilization, page 8-8

Notice

Use the information in this section only if the handpiece is to be sterilized with items, accessories and manifold tubing at 132°C (270°F). If handpieces are to be sterilized at 134°C (273°F), assembly should be done in the sterile field. Refer to Sterilization Parameters, page 9-1.

For Your Information

You have two options:

1. NOT Changing Tips in the Sterile Field – If assembling the tip to the handpiece in a nonsterile area before sterilization, see the following instructions in this User's Guide:
 - ▶ *Section 8: Assembling the Handpiece in a Nonsterile Area*
 - ▶ *Section 9: Sterilizing Handpieces and Accessories*
 - ▶ *Section 10: Completing Handpiece Setup in the Sterile Field*

2. Assembling or Changing Tips in the Sterile Field – For instructions on how to assemble and disassemble the handpiece as part of changing tips in the sterile field, refer to *Section 11: Assembling or Changing Tips in the Sterile Field*.

- Important notes: Use the same procedure to assemble the 23 kHz straight, 23 kHz angled, and 36 kHz straight handpieces.
- Handpiece cable connectors, tip pack packaging, manifold tubing packaging, nosecone packaging, slots in the tip torquing base, torque wrench heads, and sterilizer tray lids are color coded:

23 kHz green

36 kHz blue

- Recommended: When you assemble a handpiece, assemble at least one backup handpiece.

Items Needed for Handpiece Assembly

The following figures illustrate the items you need to assemble the handpiece. The tip, o-rings, and flue are part of tip packs.

Figure 8-1 The items you need to assemble a handpiece: handpiece, nosecone, and tip pack

Handpiece

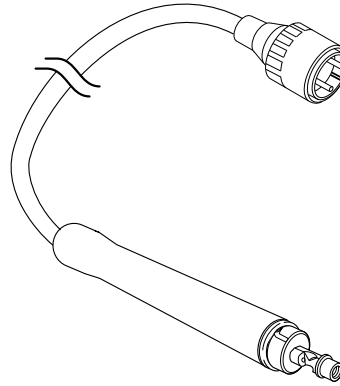

Standard nosecone

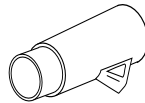

(Content of Tip Pack)

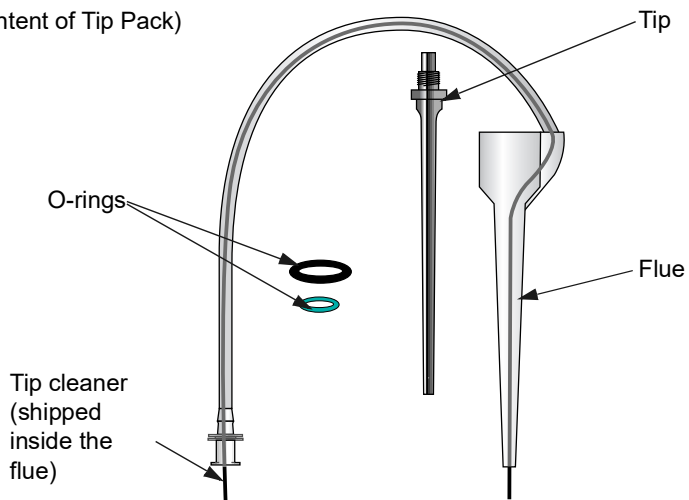
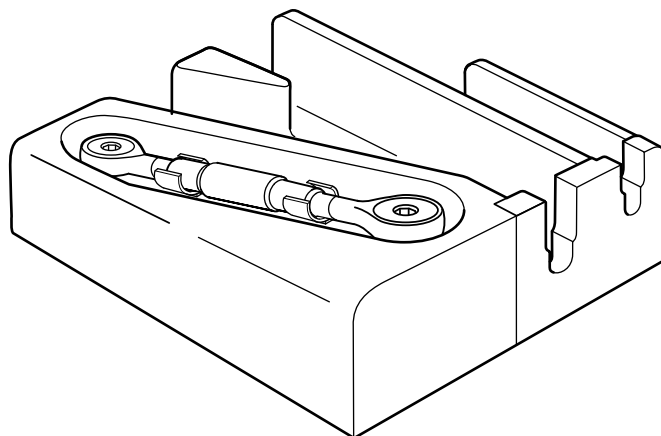

Figure 8-2 Tip torquing base and torque wrench (for use in non-sterile field)



You also need a tip torquing base and torque wrench to assemble a handpiece.

Manifold tubing is sterile, single use only. Discard the manifold tubing after one use. You have two options for attaching the tubing to the handpiece:

- Attach the manifold tubing before sterilization
- Attach the manifold tubing in the sterile field

Notice

Attach manifold tubing before sterilization only if the handpiece is to be sterilized with manifold tubing at 132°C (270°F). If handpieces are to be sterilized at 134°C (273°F), assembly of manifold tubing should be done in the sterile field. Refer to Sterilization Parameters, page 9-1.

Figure 8-3 Manifold tubing

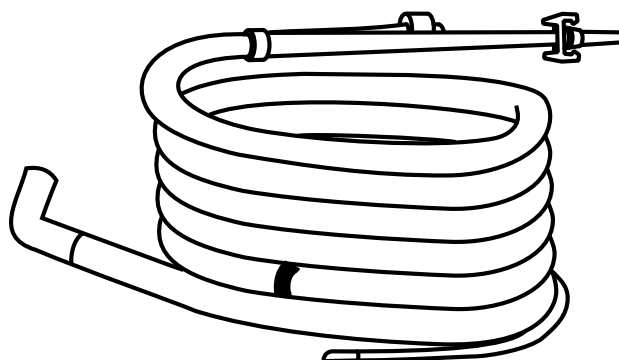

Warning

Single Use devices are for single patient use only. Do not reprocess or re-use. Device(s) is (are) intended to be used for one procedure only. If reprocessed or re-used this may result in the infection of patient (or patient specimen) through cross-contamination, as well as would incur the risk of modifying the properties and performance of the device, and of increasing the likelihood of complications and/or undesirable effects. Once used, devices must be disposed of in accordance with hospital policies.

Attaching the Tip to the Connecting Body

1. Thread the tip of choice onto the handpiece connecting body. Turn the tip until it is finger tight.

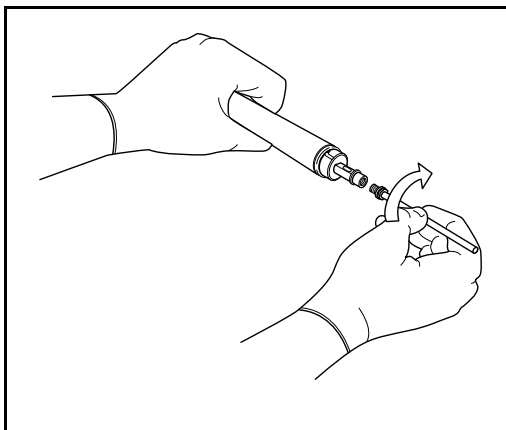

2. Locate the slot in the tip torquing base that matches the color on the handpiece connector (23 kHz – green; 36 kHz – blue). Put the handpiece in the tip torquing base so that the metal connecting body fits snugly in the metal end of the slot.

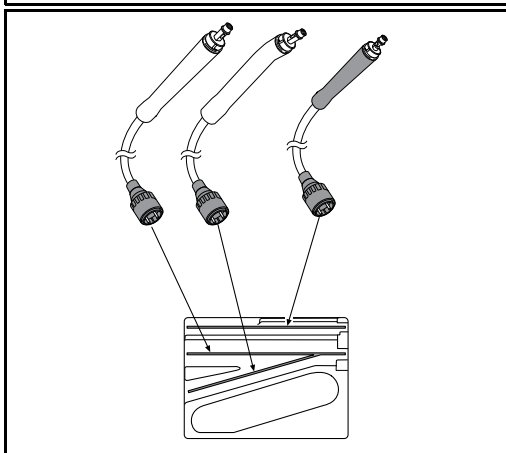

3. Hold the handpiece in place in the tip torquing base.

Caution

To avoid product damage, **NEVER** hold the handpiece in your hand while using the torque wrench to tighten or loosen the tip.

4. Match the colored end of the torque wrench with the handpiece color. Slide the color coded side of the wrench over the tip, being careful not to damage the tip, until the hex in the wrench engages the hex of the tip.

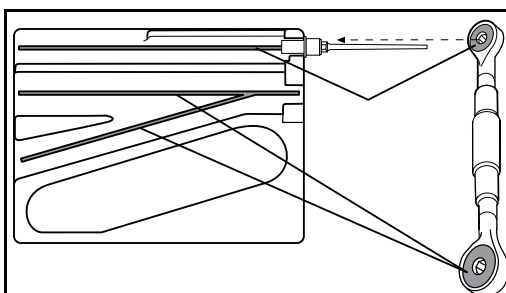

5. Rotate the wrench clockwise until you feel and hear a click. Rotate again until you feel and hear a second click.

Warning

Turning the torque wrench further clockwise will damage the handpiece.

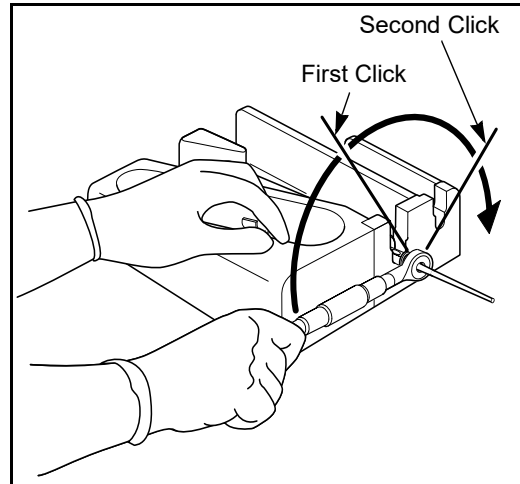

6. Remove the wrench from the tip.
7. Remove the handpiece from the tip torquing base.

Putting On the O-Rings

1. Locate the o-rings for the handpiece you are assembling:

	23 kHz	36 kHz
Large o-ring	black	white
Small o-ring	green	blue

2. Slide the larger o-ring over the connecting body and into the groove in the neck of the handpiece. Slide the smaller o-ring into the groove in the metal connecting body.

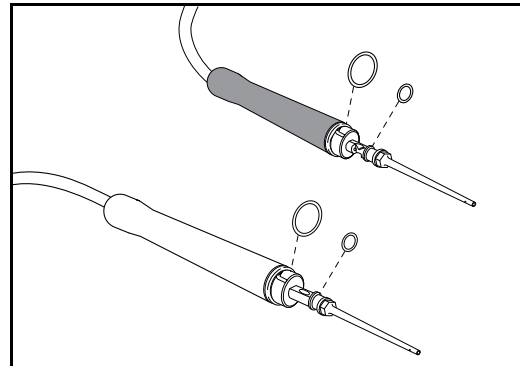

Caution

Do not assemble the nosecone to the handpiece until both the handpiece and nosecone are sterile.

Clipping the Manifold Tubing to the Handpiece Cable (Optional)

Manifold tubing is sterile, single patient use only. You can sterilize unused manifold tubing once. You have two options for attaching the tubing to the handpiece:

- Attach the manifold tubing before sterilization
- Attach the manifold tubing in the sterile field

Whether you attach the tubing before or after sterilization, discard it after one use.

Warning

Single Use devices are for single patient use only. Do not reprocess or re-use. Devices (s) is (are) intended to be used for one procedure only. If reprocessed or re-used this may result in the infection of patient (or patient specimen) through cross-contamination, as well as would incur the risk of modifying the properties and performance of the device, and of increasing the likelihood of complications and/or undesirable effects. Once used, devices must be disposed of in accordance with hospital policies.

Notice

Attach manifold tubing before sterilization only if the handpiece is to be sterilized with manifold tubing at 132°C (270°F). If handpieces are to be sterilized at 134°C (273°F), assembly of manifold tubing should be done in the sterile field. Refer to Sterilization Parameters, page 9-1.

If you decide to clip the manifold tubing onto the handpiece cable before sterilization, follow this procedure:

1. Remove the manifold tubing with clips from the packaging. Uncoil the tubing.
2. Snap the handpiece clip in place on the handpiece housing.

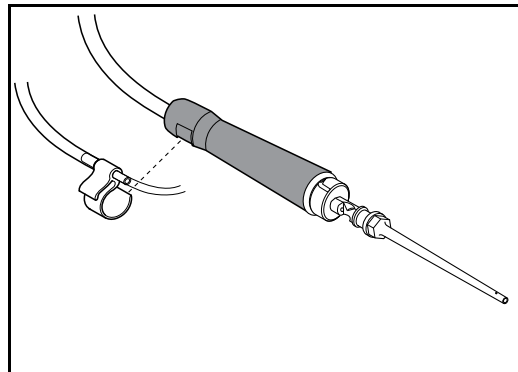

3. Push one to three manifold tubing clips onto the handpiece cable.

Note: It is only necessary to attach one to three clips, but you can attach all five clips in the package.

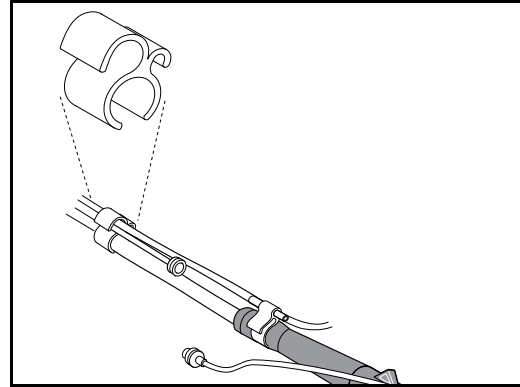

Packaging the Handpiece for Sterilization

After you have assembled the handpiece, prepare it for sterilization. Integra provides sterilizer cases for steam sterilization of the CUSA[®] Excel/CUSA[®] Excel+ System handpieces. These cases protect the handpieces during sterilization and during transfer to the sterile field. The case for the 23 kHz handpiece is gray; for the 36 kHz handpiece, white.

Items Needed

You will need the sterilizer case provided by Integra.

Figure 8-4 The sterilizer case

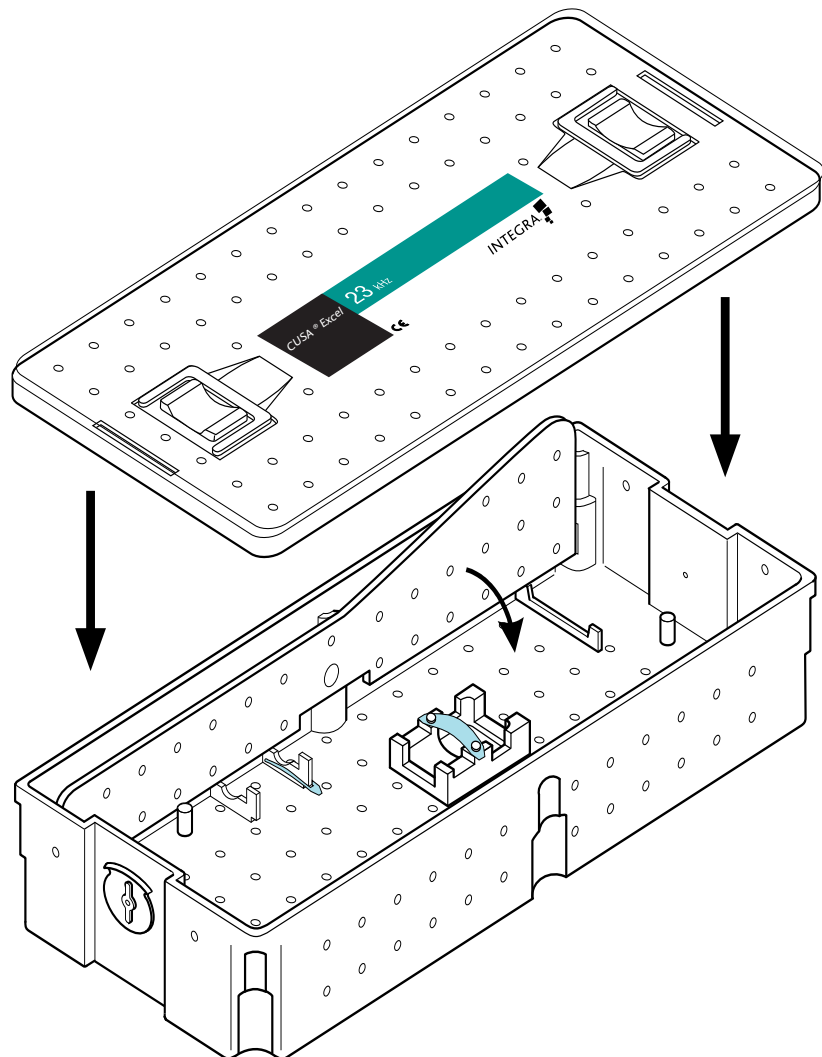

1. Put the handpiece into the case first. Align the handpiece with the outline on the case bottom. Secure the handpiece with the silicone strap.
2. Place the nosecone and flue with the tip cleaner in the handpiece compartment.
3. Close the protective cover over the handpiece.
4. Coil the cable and manifold tubing (if attached) around the inside of the case.
5. Put the handpiece connector in the center compartment and secure it in place.
6. Put on the lid. Close and latch the case.

Figure 8-5 The handpiece and connector secured into the sterilizer tray

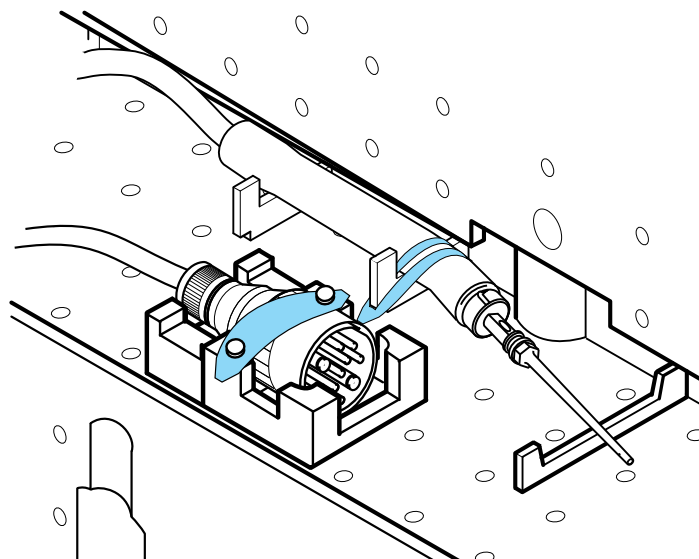

Sterilizing Handpieces and Accessories

In this section:

- For Your Information, page 9-1
- Sterilization Parameters, page 9-1
- Sterilizing the Handpiece with Steam, page 9-3

For Your Information

After preparing the handpiece, sterilize it using steam. This section describes the steam sterilization parameters.

Sterilization Parameters

Sterilize CUSA[®] Excel/CUSA[®] Excel+ handpieces and accessories with steam. For information on preparing the handpiece for sterilization, see Packaging the Handpiece for Sterilization, page 11-15.

The following tables provide the minimum parameters:

Packaging

Wrapped: Sterilizer case double wrapped in hospital CSR material.

Flash: Sterilizer case unwrapped.

Handpieces without Accessories

Packaging	Temp	Type	Time	Dry Cycle
Wrapped	132°C or 270°F	Prevac	4 min	20 min
	134°C or 273°F	Prevac	18 min	20 min Autoclave/ Vacuum
Flash (Unwrapped)	132°C or 270°F	Prevac	4 min	none
	134°C or 273°F	Prevac	18 min	20 min Autoclave/ Vacuum

Handpieces with Accessories

Packaging	Temp	Type	Time	Dry Cycle
Wrapped	132°C or 270°F	Prevac	4 min	20 min
Flash (Unwrapped)	132°C or 270°F	Prevac	4 min	none

Notice

Accessories include the nosecone, manifold tubing, tip pack contents (tip, flue, tip cleaner, o-rings) and sterilizable tip torquing base.

For information on the validation procedure for the steam sterilization parameters defined here, see Validation of Steam Sterilization Parameters, page B-1.

Sterilizing the Handpiece with Steam

Sterilizing the handpiece with steam depends on the following factors:

- Temperature
- Exposure time
- Population and resistance of resident bioburden
- Method of air removal from the autoclave

Use the validated steam sterilization cycle parameters in these instructions. If you deviate from this recommended method of sterilizing, it is your Health Care Facility's responsibility to validate the deviations.

For sterilizing the handpiece with steam, do not exceed 138° C (280°F).

After steam sterilization, the handpiece cable may appear collapsed. This is normal. The cable regains its shape in about one hour. This does not affect the handpiece performance or safety.

Notes

Completing Handpiece Setup in the Sterile Field

In this section:

- For Your Information, page 10-1
- Quick Reference – Setup, page 10-2
- Completing the Handpiece Assembly, page 10-2

For Your Information

This section describes how to complete the handpiece setup in the sterile field. It begins with the arrival of the sterilized handpiece and accessories in the operating room. It ends with the handpiece ready to be connected to the console.

Notice

Retaining a spare handpiece in the sterile field is highly recommended.

Quick Reference – Setup

Use this list if you are a knowledgeable user who needs only a reminder of the steps to set up the CUSA[®] Excel/CUSA[®] Excel+ System.

Handpiece Assembly

1. Attach a standard nosecone onto the handpiece.
2. Attach the flue.
3. Attach the sterile manifold tubing (if not attached before sterilization).
4. Attach the aspiration and irrigation tubes at the handpiece.

Completing the Handpiece Assembly

You have the option of attaching manifold tubing to the handpiece cable before or after sterilization. If you chose to attach the tubing after sterilization, you must attach it in the sterile field.

Items Needed

You need the following items to set up the handpiece for surgery:

- Standard nosecone
- Flue
- Manifold tubing

Attach a Nosecone

1. Attach a standard nosecone. Holding the handpiece, insert the tip into the nosecone.

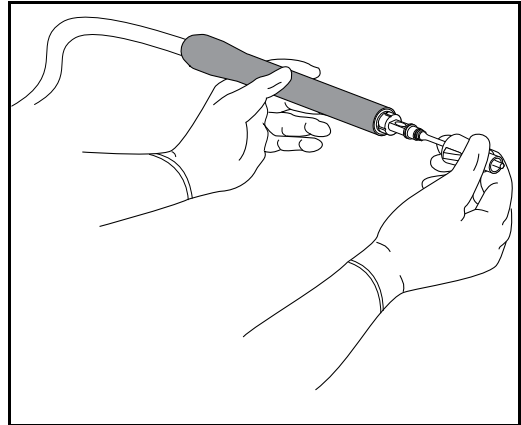

2. Align the dot on the nosecone with the dot on the neck of the handpiece.
3. Push the nosecone onto the handpiece so that the dots are on top of each other.

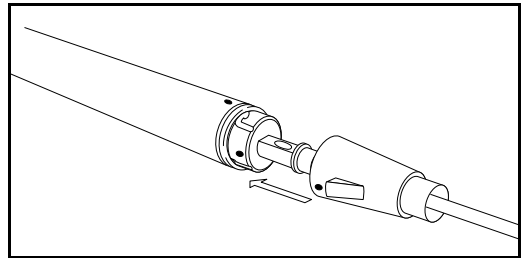

4. Twist the nosecone clockwise until it locks into place.

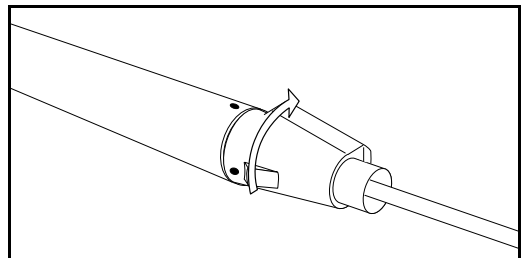

5. The dot on the nosecone must now align with the dot on the handpiece.

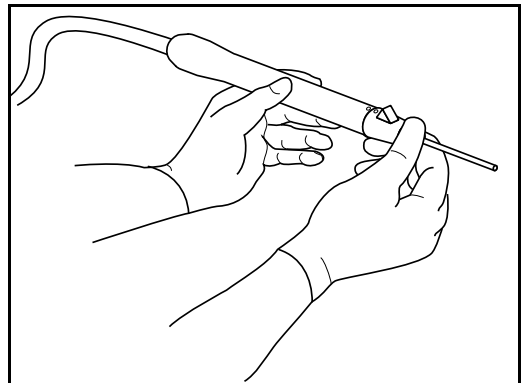

6. Remove the tip cleaner, and slide the flue that corresponds to the selected tip over the tip and onto the nosecone. Make sure to push the flue base completely over the nosecone base, and that the end of the flue lines up with the pre-aspiration holes.

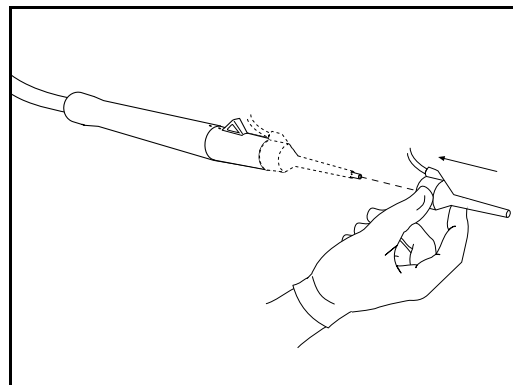

Clip the Manifold Tubing to the Handpiece Cable

If you receive the sterilized handpiece without the manifold tubing already clipped onto the handpiece cable, you must attach the manifold tubing now. Follow this procedure:

1. Remove the manifold tubing with clips from the packaging. Uncoil some of the tubing.
2. Snap the handpiece clip in place on the handpiece housing.

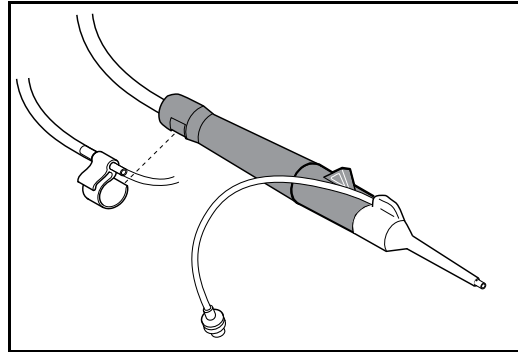

3. Insert the irrigation tube from the flue into the handpiece clip.

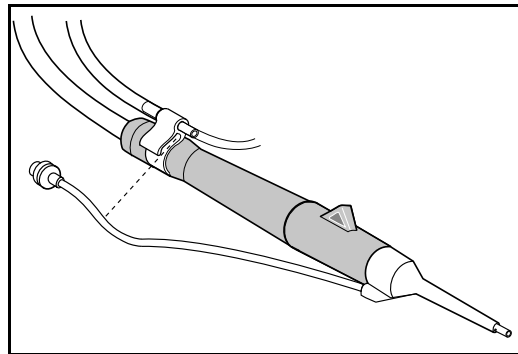

4. Connect the manifold irrigation tubing to the Luer fitting on the handpiece flue:

(Viewed from rear)

- a. Connect the Luer fitting.

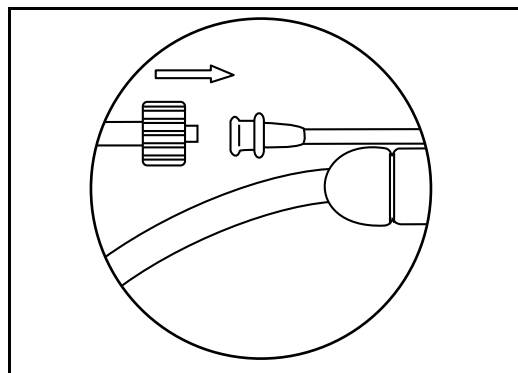

- b. Twist the knob clockwise to lock the fitting.

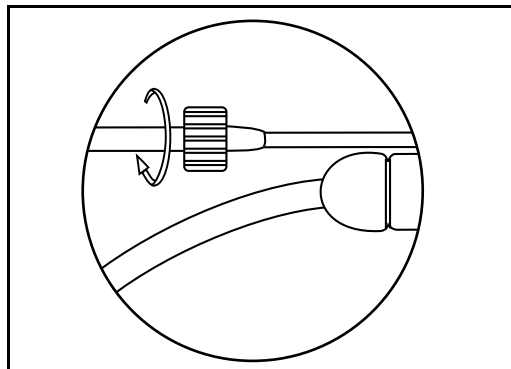

5. Connect the manifold suction tubing and clip to the suction port in the nosecone.

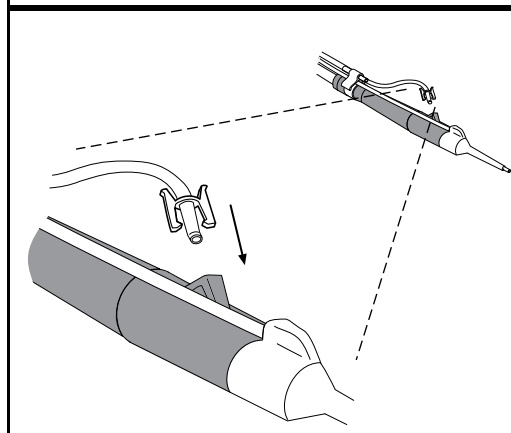

6. Push one to three manifold tubing clips onto the handpiece cable.

Note: It is only necessary to attach one to three clips, but you can attach all five clips in the package.

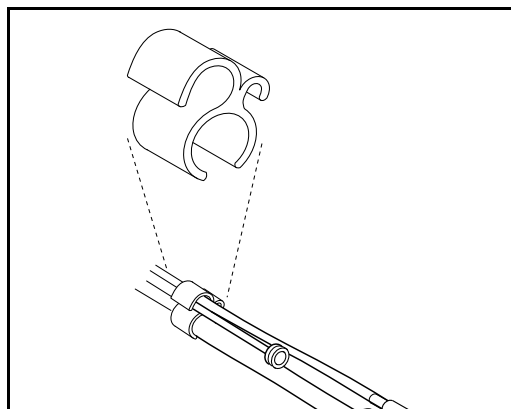

7. Hand off the remaining manifold tubing, handpiece cable, and handpiece electrical connector to the circulator.

Assembling or Changing Tips in the Sterile Field

In this section:

- For Your Information, page 11-1
- Items Needed to Change Tip in Sterile Field, page 11-2
- Assembling the Tip, page 11-5
- Disassembling Handpiece to Change Tips in the Sterile Field, page 11-10
- Disassembling Handpiece After the Surgical Procedure, page 11-13
- Resterilizing the Handpiece, page 11-14
- Resterilizing the Sterilizable Torque Base, page 11-14
- Packaging the Handpiece for Sterilization, page 11-15
- Packaging the Base for Sterilization, page 11-16
- Sterilize the Handpiece and Base, page 11-17

For Your Information

You have two options:

1. Assembling or Changing Tips in the Sterile Field – This section explains how to assemble and disassemble the handpiece as part of changing tips in the sterile field.
2. NOT Changing Tips in the Sterile Field – If assembling the tip to the handpiece in a nonsterile area before sterilization, see the following instructions:

- ▶ Section 8: Assembling the Handpiece in a Nonsterile Area
- ▶ Section 9: Sterilizing Handpieces and Accessories
- ▶ Section 10: Completing Handpiece Setup in the Sterile Field

Important notes:

- Use the same procedure to assemble the 23kHz straight, 23kHz angled, and 36kHz handpieces
- Handpiece cable connectors, manifold tubing packaging, tip/flue packaging, nosecone packaging, slots in the tip torquing bases, and sterile torque wrenches are color coded:

23kHz green

36kHz blue

- Recommended: When you assemble a handpiece, assemble at least one backup handpiece.

Items Needed to Change Tip in Sterile Field

You need the following items to change tips in the sterile field:

- Sterilized handpiece(s)
- Sterilized standard nosecone
- Sterile tip/flue pack(s) or sterilized extended life tips and flues
- Sterilized tip torquing base
- Sterile torque wrench (23 kHz or 36 kHz)
- Sterile manifold tubing

The following figures illustrate these items.

Figure 11-1 The sterilized handpiece

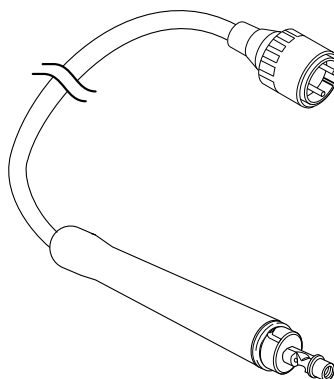
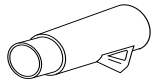

Figure 11-2 The sterilized standard nosecone



The contents of sterile tip/flue packs are sterile, single use only. You can resterilize unused tips and flues once.

The contents of extended life tip/flue packs are nonsterile. You can use them six times. If you use extended life tips and intend to attach the tip in the sterile field, ensure tips and flues are sterile before they are introduced to the sterile field.

You have two options for attaching tips to the handpiece:

- Attach the tip in the sterile field
- Attach the tip before sterilizing the handpiece (If you use this option, do not change tips in the sterile field because the area under the tip threads will not be sterile)

Figure 11-3 Sterile tip/flue pack contents. The tip cleaner is inside the flue.

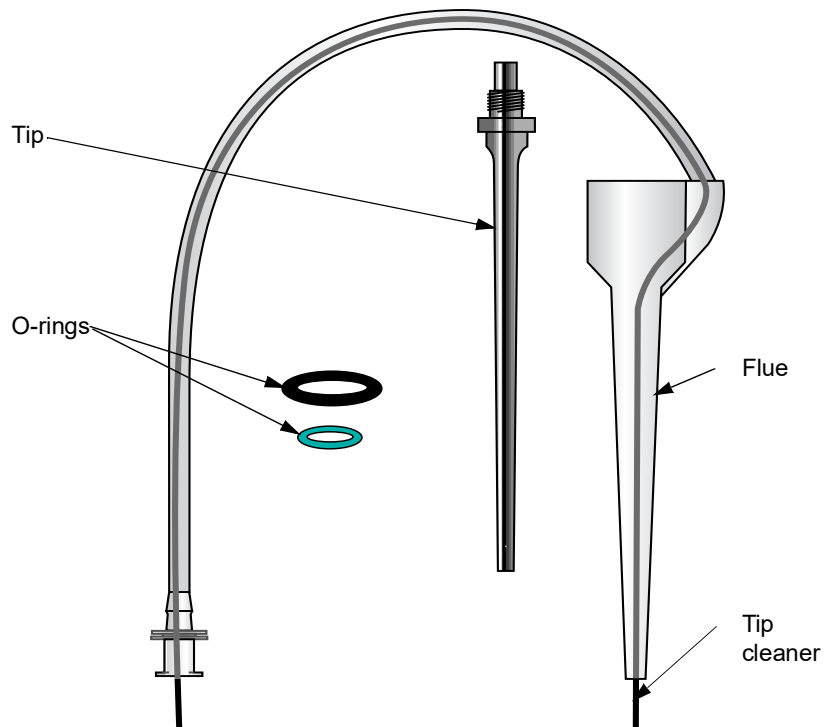

Steam sterilize the tip torquing base before each surgical procedure in which you change tips in the sterile field.

Figure 11-4 Sterilizable tip torquing base

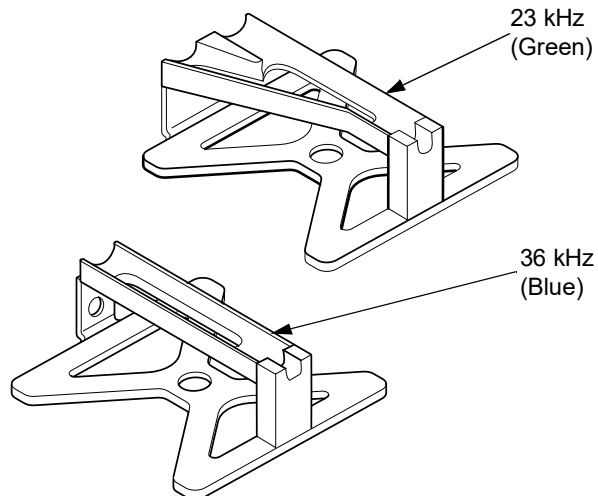

You can use the sterile torque wrench to change as many as five tips in one surgical procedure. Do not use the sterile torque wrench in more than one surgical procedure. Do not sterilize the sterile torque wrench; dispose of the used sterile torque wrench in accordance with your Healthcare Facility protocols.

Figure 11-5 Sterile torque wrench (23 kHz or 36 kHz)

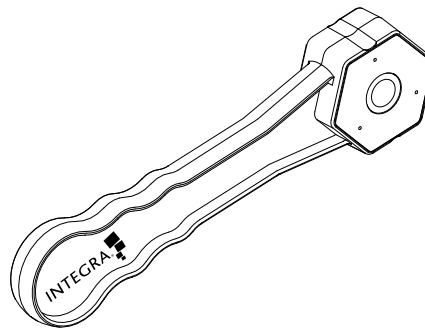

Manifold tubing is sterile, single patient use only. You can resterilize unused manifold tubing once. You have two options for attaching the tubing to the handpiece:

- Attach the manifold tubing in the sterile field
- Attach the manifold tubing before sterilizing the handpiece

Figure 11-6 Sterile manifold tubing

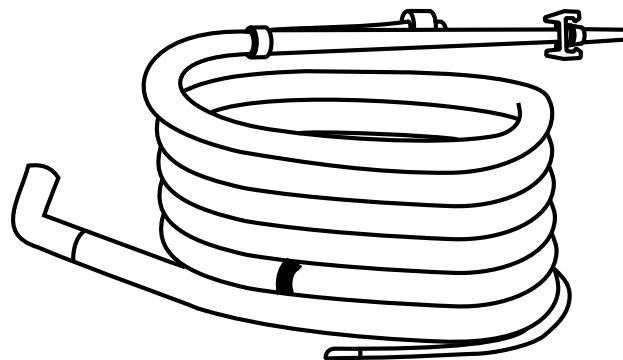

Notice

Attach manifold tubing only if the handpiece is to be sterilized with manifold tubing at 132°C (270°F). If handpieces are to be sterilized at 134°C (273°F), assembly of manifold tubing should be done in the sterile field. Refer to Sterilization Parameters, page 9-1.

Warning

Single Use devices are for single patient use only. Do not reprocess or re-use. Devices (s) is (are) intended to be used for one procedure only. If reprocessed or re-used this may result in the infection of patient (or patient specimen) through cross-contamination, as well as would incur the risk of modifying the properties and performance of the device, and of increasing the likelihood of complications and/or undesirable effects. Once used, devices must be disposed of in accordance with hospital policies.

Assembling the Tip

For this procedure, use the sterile, disposable torque wrench (C5601 for 23 kHz or C5602 for 36 kHz) and the sterilizable torque base (C5623 for 23 kHz or C5636 for 36 kHz).

Warning

The handpiece and handpiece accessories must be sterile before surgical use.

Attach the Tip and O-rings

1. Thread the tip of choice onto the handpiece connecting body. Turn the tip until it is finger tight.

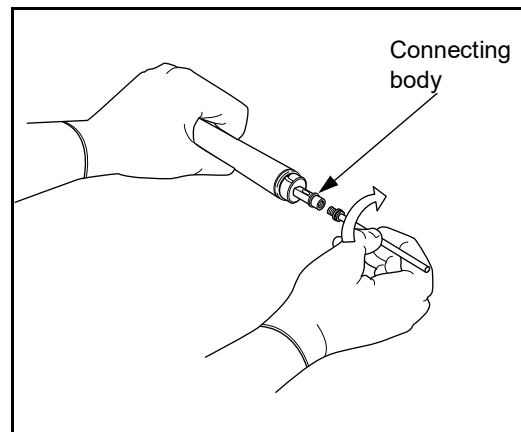

2. The sterilized torque base should be in the sterilizer tray. Verify that the handpiece support color on the torque base matches the color on the handpiece connector (23 kHz – green; 36 kHz – blue). Remove the sterilized torque base from the sterilizer tray.

- Put the handpiece in the torque base so that the metal connecting body fits snugly in the metal slot at the end of the support.

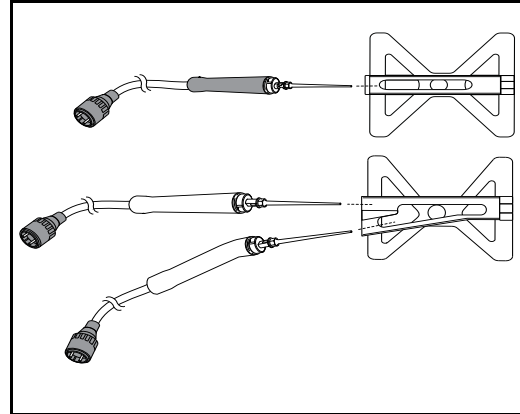

- Match the colored ring on the sterile torque wrench with the handpiece connector color or handpiece support color on the torque base. Slide the color coded side of the wrench over the tip, being careful not to damage the tip, until the hex in the wrench engages the hex of the tip.

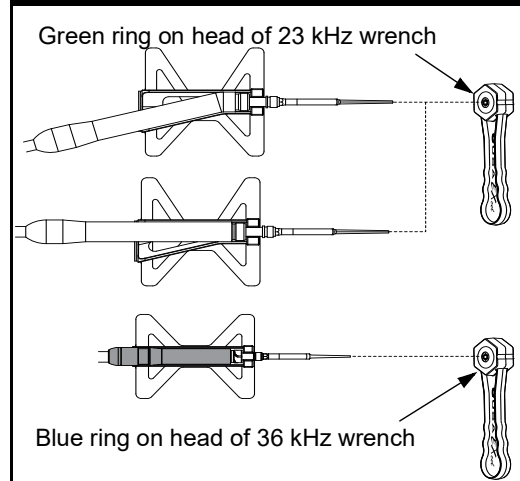

- Hold the handpiece in place in the tip torquing base.

Caution

To avoid product damage, NEVER hold the handpiece in your hand while using the torque wrench to tighten or loosen the tip.

- Rotate the wrench clockwise until you feel and hear one click. Rotate again until you feel and hear a second click.

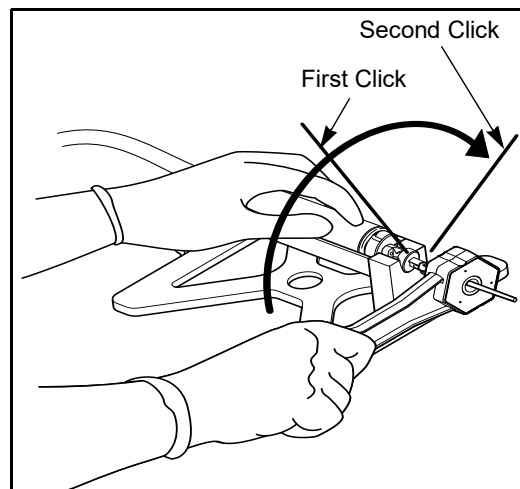

Warning

Turning the torque wrench further clockwise will damage the handpiece.

7. Carefully remove the sterile wrench from the tip.
8. Remove the handpiece from the tip torquing base.
9. Locate the o-rings for the handpiece you are assembling:

	23 kHz	36 kHz
Large o-ring	black	white
Small o-ring	green	blue

10. Slide the larger o-ring over the connecting body and into the groove in the neck of the handpiece. Slide the smaller o-ring into the groove in the metal connecting body.

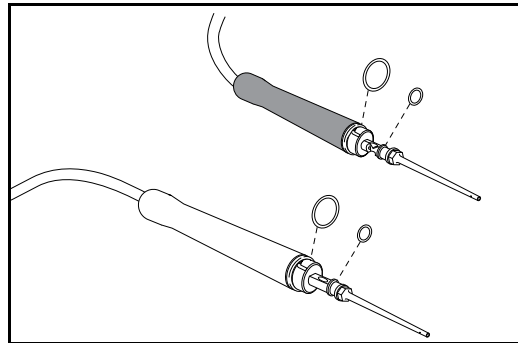

Attach a Nosecone and Flue

Attach a standard nosecone.

1. Holding the handpiece, insert the tip into the nosecone.

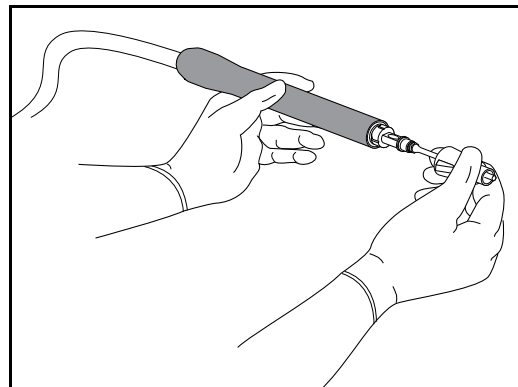

2. Align the dot on the nosecone with the dot on the neck of the handpiece.
3. Push the nosecone onto the handpiece so that the dots are on top of each other.

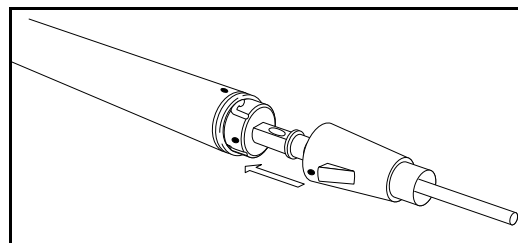

4. Twist the nosecone clockwise until it locks into place.
The dot on the nosecone must now align with the dot on the handpiece.

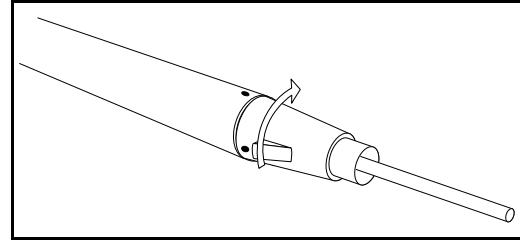

5. Remove the tip cleaner from the flue and set it aside. You may need it during the surgical procedure to remove tissue blockage from the tip, the suction connection to the handpiece, or both.
6. Slide the flue that corresponds to the selected tip over the tip and onto the nosecone.

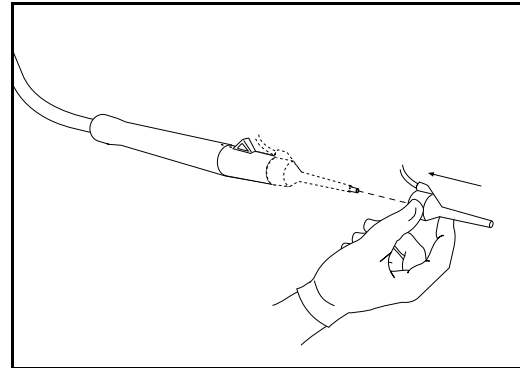

Markings on the flue indicate the tip the flue should cover:

S	Standard Tip
Mi	MicroTip™, ShearTip™, SaberTip™
Mit	MicroTip™ Plus
P	PrecisionTip™
Ma	MacroTip™

Make sure to push the flue base completely over the nosecone base, and that the end of the flue lines up with the pre-aspiration holes.

Attach the Manifold Tubing

If you receive the sterilized handpiece without the manifold tubing already clipped onto the handpiece cable, you must attach the manifold tubing now. Follow this procedure:

1. Remove the manifold tubing with clips from the packaging. Uncoil some of the tubing.
2. Snap the handpiece clip in place on the handpiece housing.

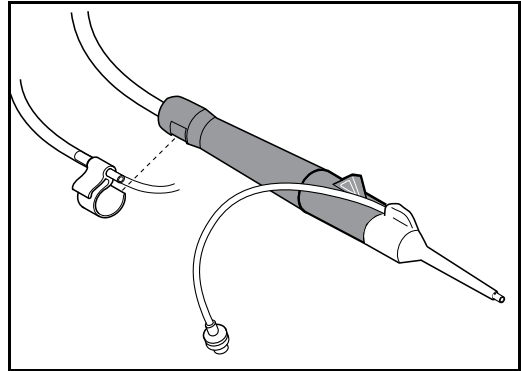

3. Insert the irrigation tube from the flue into the handpiece clip.

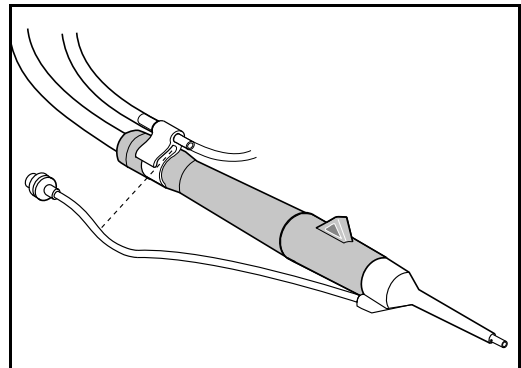

4. (Viewed from rear) Connect the manifold irrigation tubing to the Luer fitting on the handpiece flue.

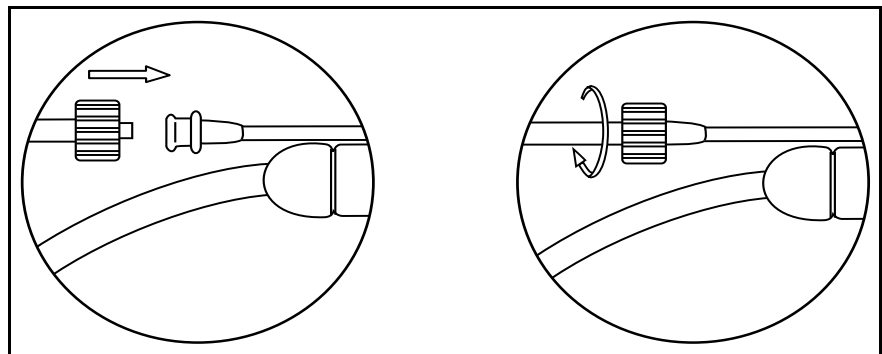

5. Connect the manifold suction tubing and clip to the suction port in the nosecone.

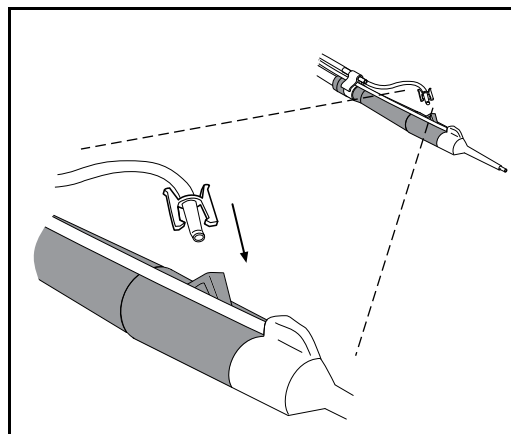

6. Push one to three manifold tubing clips onto the handpiece cable.

Note: It is only necessary to attach one to three clips, but you can attach all five clips in the package.

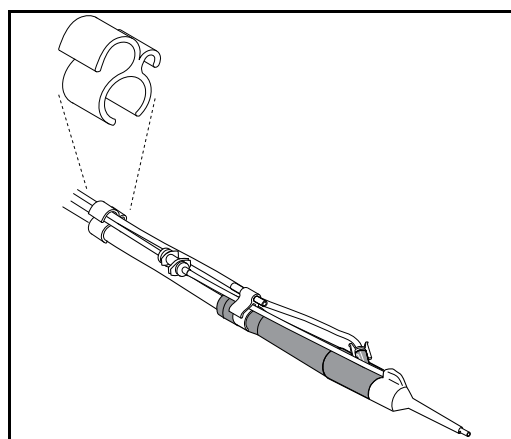

Disassembling Handpiece to Change Tips in the Sterile Field

Use this procedure only if you are disassembling the handpiece as part of changing tips in the sterile field. To disassemble the handpiece at the end of the surgical procedure, see Section 13: Disassembling and Cleaning Handpieces.

1. Press the Status button to put the system in Standby.

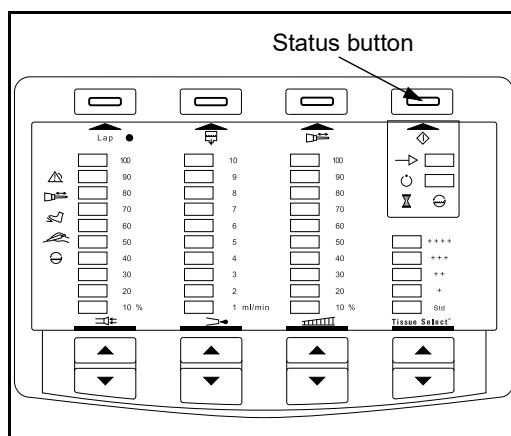

Disconnect the Manifold Tubing

1. (Viewed from rear) Disconnect the irrigation tubing from the handpiece flue.

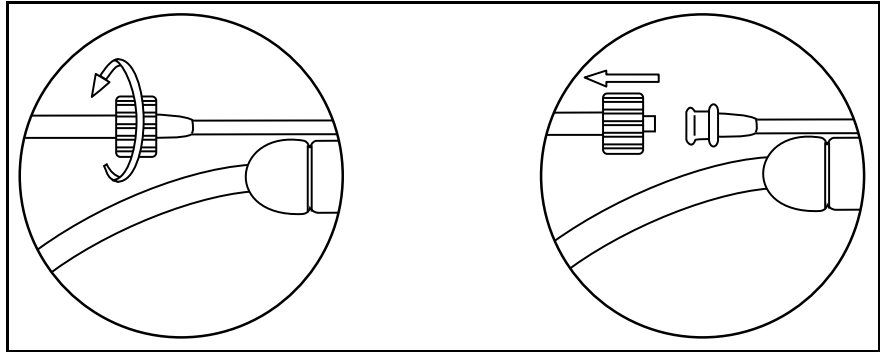

2. Remove the flue irrigation tube from the handpiece clip.
3. Remove the flue and set it aside.
4. Disconnect the manifold suction tubing and its clip from the handpiece and nosecone.

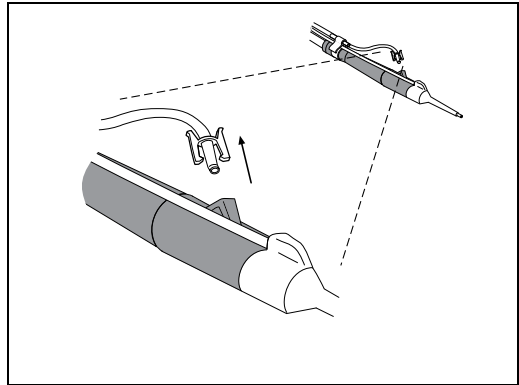

Remove the Nosecone, O-rings, and Tip

1. Remove the standard nosecone:
 - a. Release the nosecone by twisting it counterclockwise.
 - b. Pull the nosecone away from the handpiece and set it aside.

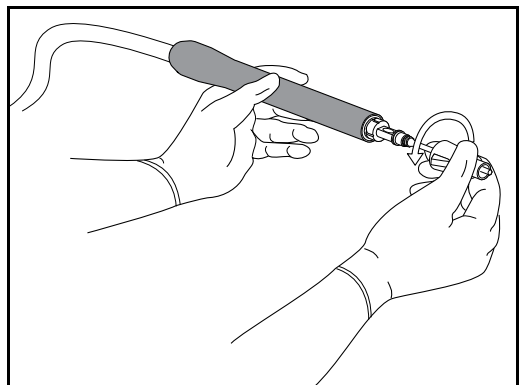

DO NOT DISCARD A STANDARD NOSECONE.

2. Locate the sterile torque base in which the handpiece support color matches the color on the handpiece connector (23 kHz – green; 36 kHz – blue).

- Put the handpiece in the torque base so that the metal connecting body fits snugly in the metal slot at the end of the support.

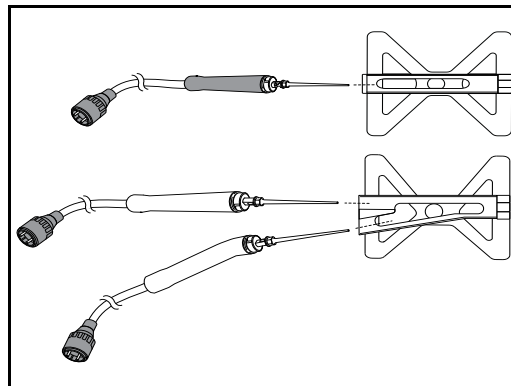

- Match the colored ring of the sterile torque wrench with the handpiece connector color or handpiece support color on the torque base. Slide the color coded side of the wrench over the tip until the hex in the wrench engages the hex of the tip.

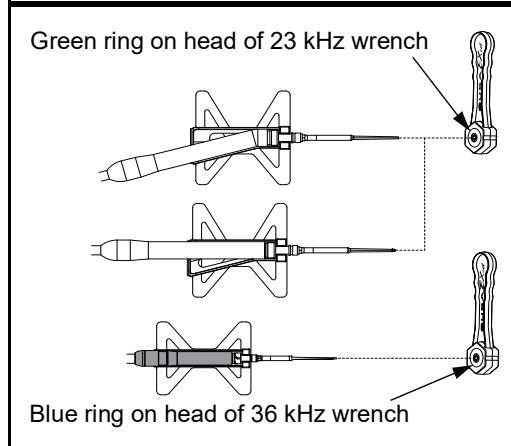

- Hold the handpiece securely in place in the torque base.

Caution

To avoid product damage, **NEVER** hold the handpiece in your hand while using the torque wrench to tighten or loosen the tip.

- Rotate the wrench counterclockwise until the tip is loose.

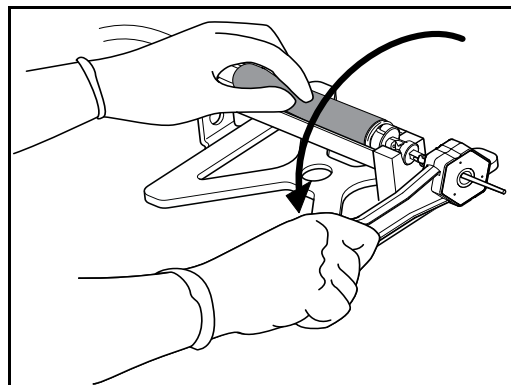

- Carefully remove the sterile wrench from the tip.
- Remove the handpiece from the tip torquing base.

9. Unscrew the used tip. Set the tip and flue aside for further use or disposal at the end of the surgical procedure.

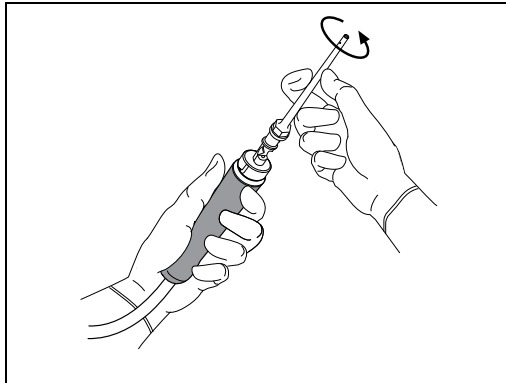

10. Using a soft cloth, wipe the handpiece connecting body surface to remove gross contaminants.

If reassembling a used tip to the handpiece, remove gross contaminants from the tip connecting surface by wiping with a soft cloth.

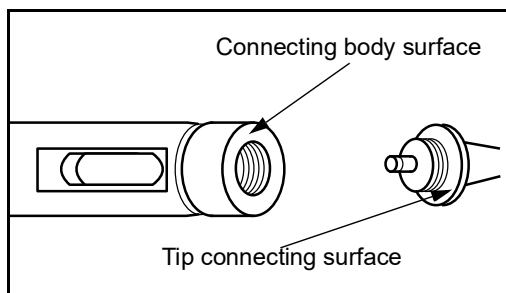

To reassemble the handpiece in the sterile field, refer to the *Assembly* earlier in this section.

Disassembling Handpiece After the Surgical Procedure

If you are disassembling the handpiece at the end of the surgical procedure, discard the following items in accordance with your Healthcare Facility's protocols:

- Flue(s)
- Manifold tubing
- Handpiece o-rings
- Tip(s) removed from the handpiece
- Sterile torque wrench
- Tip cleaner

Do not discard these items:

- Handpiece
- Standard nosecone
- Sterilizable torque base

Note: Do not discard the reusable tip at the end of the surgical procedure. Reusable tips can be reused six times.

See section Disassembling the Handpiece, page 13-2 for further information on disassembling handpieces.

When you have disassembled the tip from the handpiece, clean the handpiece and the sterilizable torque base, following the cleaning procedures described below.

Resterilizing the Handpiece

Clean the handpiece, either manually or by using an automatic washer. For instructions on handpiece cleaning, refer to *Cleaning the Handpiece*, page 13-4.

Resterilizing the Sterilizable Torque Base

This procedure was developed in accordance with the professional recommendations of the Association for the Advancement of Medical Instrumentation (AAMI) and the Association of periOperative Registered Nurses (AORN).

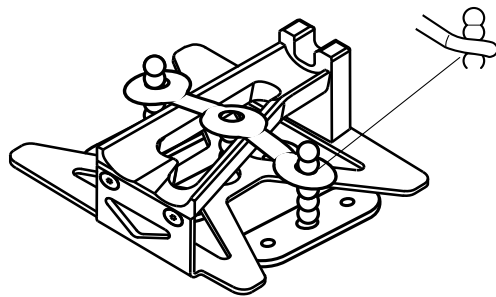

23 kHz

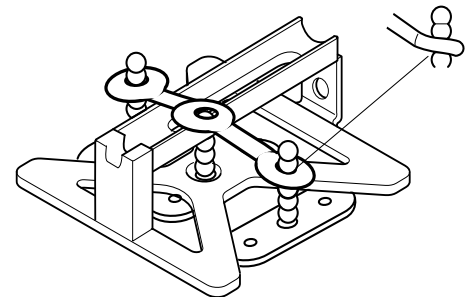

36 kHz

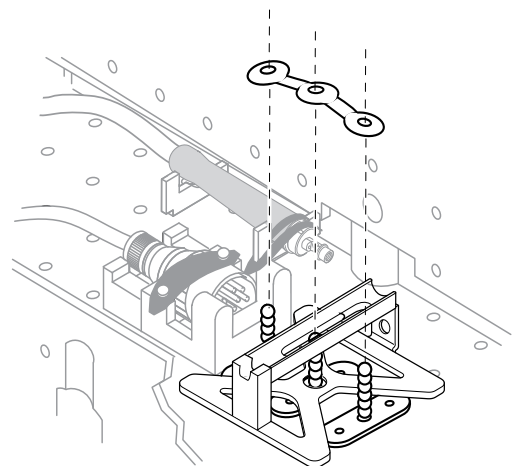
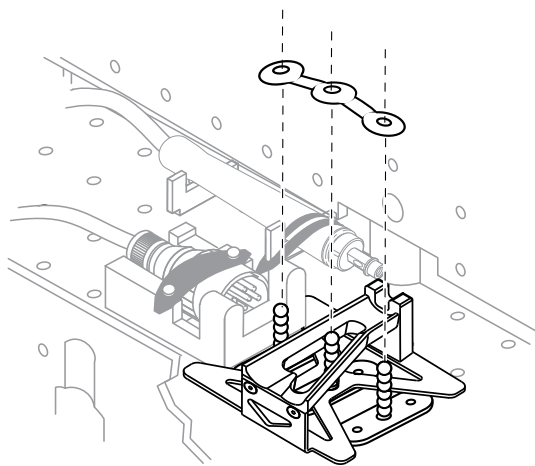

Cleaning efficacy has been validated using enzymatic cleaning agents (for example, Klenzyme[®] and Enzol[®]) according to the manufacturer's instructions.

After disassembling the tip from the handpiece, clean, then sterilize, the sterilizable torque base. Refer to the cleaning instructions below.

Clean the Base

Notice

Product damage will result if you do not follow these notices when cleaning the handpiece:

- Do not use ultrasonic washers
- Do not use chlorinated substances such as bleach solution
- Do not clean the handpiece with abrasives such as Ajax, Comet, or steel wool

1. Remove all gross matter (blood, mucous, and tissue):
 - a. Dampen a soft cloth with a cleaning agent.
 - b. Thoroughly wipe all surfaces of the base. Follow the procedures approved by your Healthcare Facility.
2. **Soak at least two minutes** in an enzymatic cleaning agent (for example, Klenzyme or Enzol) according to the manufacturer's instructions.
3. Scrub all surfaces with a small soft brush.
4. Rinse thoroughly with water.
5. Dry with a clean soft cloth.

Packaging the Handpiece for Sterilization

After you have cleaned the disassembled handpiece, prepare it for sterilization. Integra provides sterilizer cases for steam sterilization of the handpieces. They protect the handpieces during sterilization and during transfer to the sterile field. The case for the 23 kHz handpiece is gray; for the 36 kHz handpiece, white.

Notice

Use the information in this section only if the handpiece is to be sterilized with items, accessories and manifold tubing at 132°C (270°F). If handpieces are to be sterilized at 134°C (273°F), sterilize the handpiece separate from the accessories and manifold tubing. Refer to Sterilization Parameters, page 9-1.

1. Put the disassembled handpiece into the case first. Align the handpiece with the outline on the case bottom. Secure the handpiece with the silicone strap.
2. Close the protective cover over the handpiece.
3. Place the nosecone into the opening in the protective cover.

4. Coil the cable and manifold tubing (if attached) around the inside of the case.
5. Put the handpiece connector in the center compartment and secure it in place.

Figure 11-7 The handpiece and connector secured into the sterilizer tray

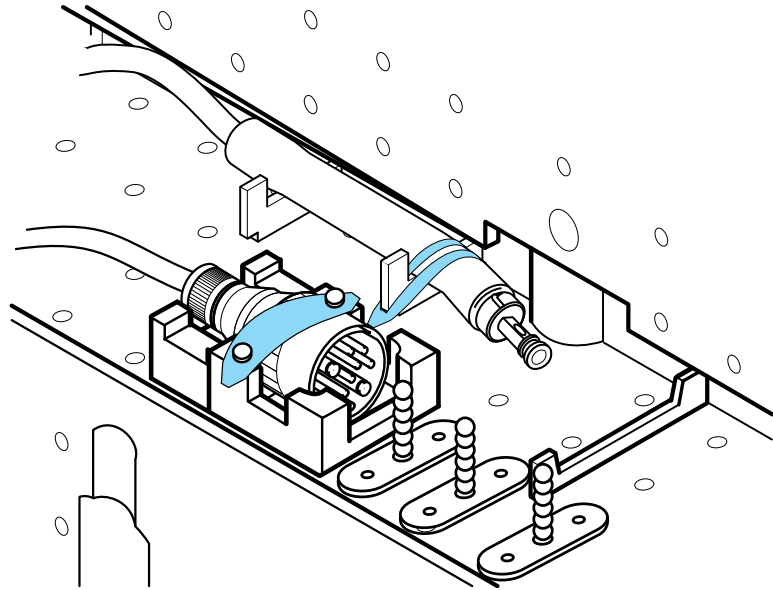

Do not close the sterilizer case until you clean and load the sterilizable torque base.

Packaging the Base for Sterilization

Notice

Package the torque base with handpiece only if the handpiece is to be sterilized with the torque base at 132°C (270°F). If the handpiece is to be sterilized at 134°C (273°F), sterilize the torque base separate from the handpiece. Refer to Sterilization Parameters, page 9-1.

1. Load the sterilizable torque base into the CUSA[®] Excel/CUSA[®] Excel+ sterilizer tray and secure it with the silicone strap.

- Put on the lid. Close and latch the sterilizer case

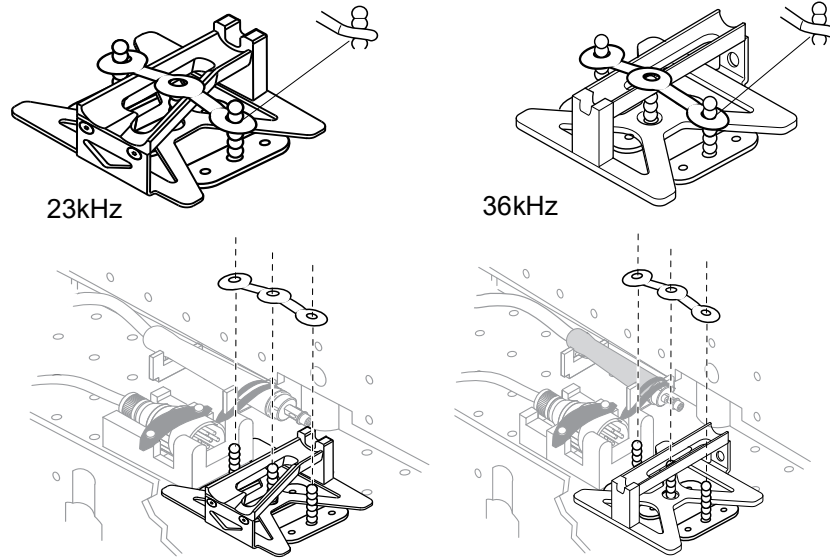

Sterilize the Handpiece and Base

Steam sterilize the handpiece and base using procedures approved by your Healthcare Facility.

For complete information on sterilization parameters, see Sterilizing Handpieces and Accessories, page 9-1.

Notes

Shutting Down, Disconnecting and Cleaning the Console

In this section:

- Shutting Down the System, page 12-2
- Disconnecting Suction Tubing, Irrigation Tubing, and the Handpiece, page 12-3
- Cleaning the Console, page 12-5

Shutting Down the System

1. Press the Status button on the system control panel.

This changes the system from Run mode to Standby mode.

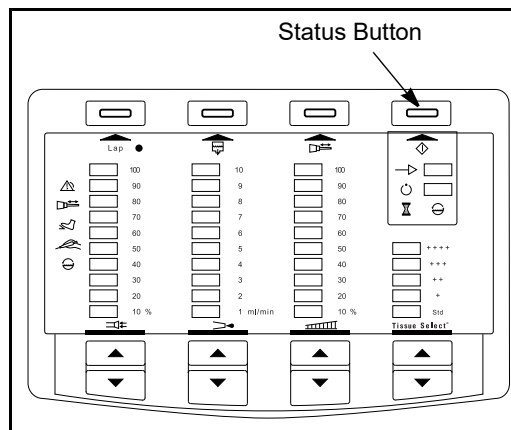

2. Turn off () the System Power Switch.

The system turns on the Wait and Cooling Water status indicators and automatically drains the handpiece cooling water. This takes about one minute. The Wait status indicator flashes.

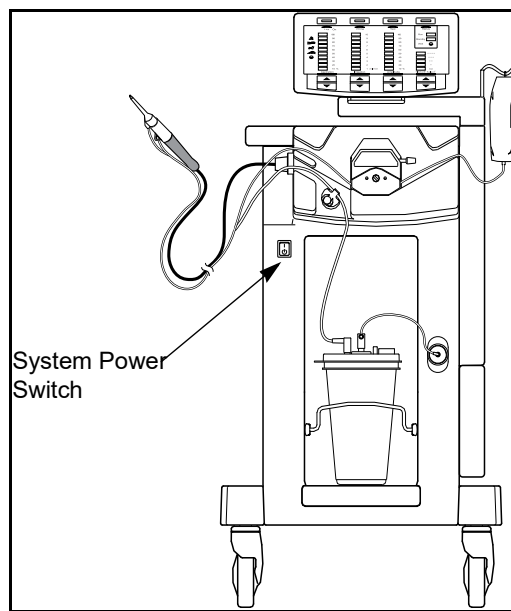

3. While the system displays the flashing Wait status indicator and the Cooling Water status indicator, remove the green-banded suction tubing from the pinch valve.

When the flashing Wait status indicator goes off, the control panel goes blank and the system automatically powers down. When this occurs, the pinch valve automatically closes. If you haven't already removed the suction tubing before the pinch valve closes, use the valve override button on the front of the pinch valve to open the valve and remove the tubing. Manually opening the valve requires a strong push on the button.

Disconnect the tubing and the handpiece, as described in the next procedure. Power down the system from the rear of the unit and unplug the system from the wall receptacle.

Notice

Do not disconnect the handpiece until the control panel goes completely blank. Otherwise, product damage may result.

Disconnecting Suction Tubing, Irrigation Tubing, and the Handpiece

1. Disconnect the green L-shaped connector on the manifold suction tubing from the suction canister. Then put the cap (if available) on the canister lid.

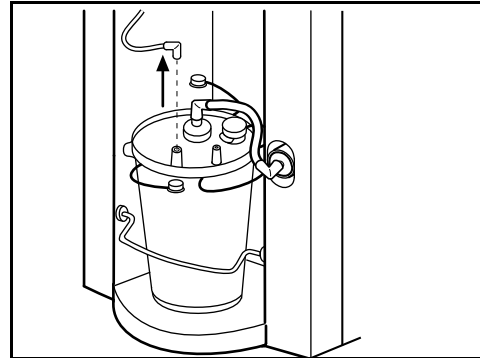

2. Disconnect the green L-shaped connector on the contamination guard tubing from the suction canister. Then put the cap (if available) on the canister lid.

Do not discard the contamination guard or tubing.

After each surgical procedure, remove and dispose of the suction canister (as per hospital bio-hazard waste protocols).

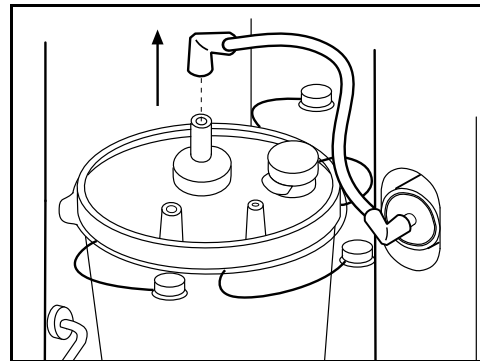

3. Close the roller clamp on the IV tubing.
4. Disconnect the IV tubing from the irrigation tubing.
5. Open the irrigation pump latch.

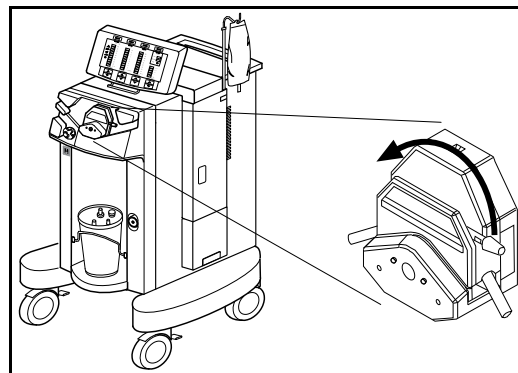

6. Remove the blue-striped manifold irrigation tubing.

7. Close the irrigation pump latch.



Warning

To avoid injury to surgical personnel:

- When closing the irrigation pump latch, keep fingers away from the area between the V-shaped tubing retainers.
- If the pump latch is open, keep fingers away from the pump rollers.

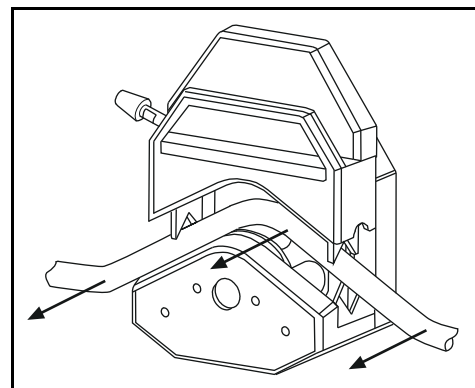

8. After all indicators on the control panel are off, remove the handpiece:

- a. Turn the handpiece connector ring counterclockwise.
- b. Remove the connector from the console.

Caution

Sharp edge at the handpiece connection point.

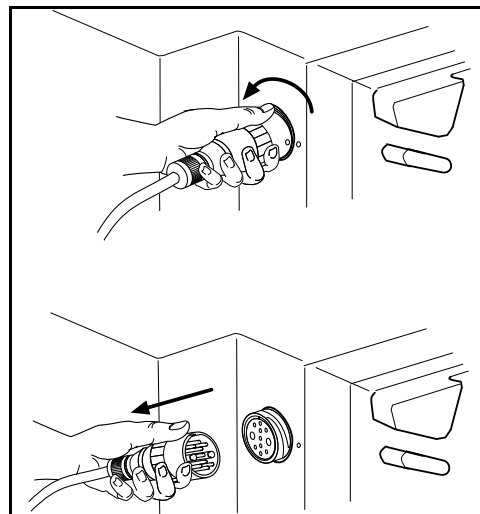

9. Remove and discard disposable components from the handpiece:

► **Important**

A standard nosecone is **not** a disposable component. **Do not discard a standard nosecone.**

- ▶ Disconnect the aspiration line from the nosecone.
- ▶ Remove the flue from the tip.
- ▶ Remove the tip from the handpiece.
- ▶ Unclip the manifold tubing from the handpiece and handpiece cable.

Discard all of these items in the patient's biohazard waste container. Do not discard a reusable tip. Reusable tips can be reused six times.

10. Empty cooling water from the cooling water reservoir:
 - a. Press the button (just above the reservoir) on the Arm Housing to release the fittings inside the housing.
 - b. Slide the reservoir toward the rear of the console, then remove it from its slot.
 - c. Gently open the black rubber lid on the reservoir top and discard the distilled water.
 - d. Gently close the black rubber lid.
 - e. Slide the empty reservoir back into the slot at the base of the adjustable arm until it snaps into place.

DO NOT DISCARD THE COOLING WATER RESERVOIR.

Cleaning the Console

Clean the CUSA[®] Excel/CUSA[®] Excel+ System surfaces and power cord. Use a mild cleaning solution or disinfectant, and a soft cloth.

Warning

Electric Shock Hazard – Always unplug the CUSA Excel/CUSA Excel+ System before cleaning it.

Notice

Do not rub, press, or touch any panels with solvents; caustic, corrosive, or abrasive cleaning or disinfectant compounds, or other materials that could scratch the panels. Do not use a betadine-based solution because it will cause discoloration. Do not allow fluids to enter the chassis.

1. Unplug the unit power cord from the wall receptacle.
2. Using standard procedures for your facility, thoroughly wipe all surfaces, cords, and the footswitch with a cleaning solution or disinfectant.
3. To ensure sufficient conductivity, clean the four wheels at the base of the console. Make sure that the surface of the wheels are free from dirt and dust. Make sure that the surface is completely dry before using the system again.

Notes

Disassembling and Cleaning Handpieces

In this section:

- For Your Information, page 13-1
- Disassembling the Handpiece, page 13-2
- Cleaning the Handpiece, page 13-4
- Permitted Number of Reprocessing Cycles for Handpieces when Cleaned with an Automatic Washer, page 13-7
- Cleaning the Tip Torquing Set, page 13-7

For Your Information

This section describes how to disassemble and clean the handpiece and tip torquing set.

Here is some information that may help as you disassemble the handpiece:

- Use the same disassembly procedure for all handpieces: 23 kHz straight, 23 kHz angled, and 36 kHz straight.
- Handpiece cable connectors, tip pack packaging, manifold tubing packaging, nosecone packaging, slots in the tip torquing base, torque wrench heads, and sterilizer tray lids are color coded:

23 kHz green

36 kHz blue

Disassembling the Handpiece

As you disassemble the handpiece, you keep some parts, and discard others. Table 13-1 shows the parts to keep and to discard (in the order in which you remove them):

Table 13-1 What to discard and what to keep

What to Discard	What to Keep
manifold tubing with clips	handpiece
flue	standard nosecone
tip cleaner	
o-rings	
tip	

Note: Do not discard a reusable tip. Reusable tips can be reused six times.

When cleaning handpieces, wear protective clothing, gloves, and safety glasses in accordance with your hospital's cleaning policy.

1. Using a soft cloth moistened with a germicidal solution, wipe the handpiece to remove gross contaminants.

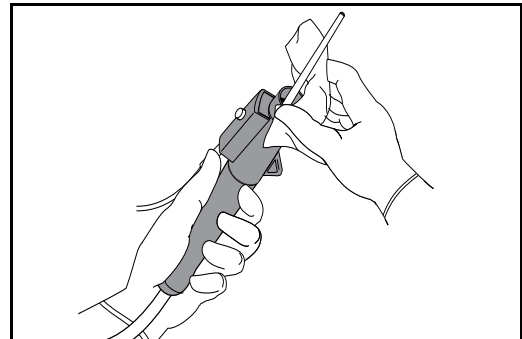

2. Remove the flue, if not already removed.
3. Remove the nosecone:

- a. Release the nosecone by twisting it counterclockwise.
- b. Pull the nosecone away from the handpiece.

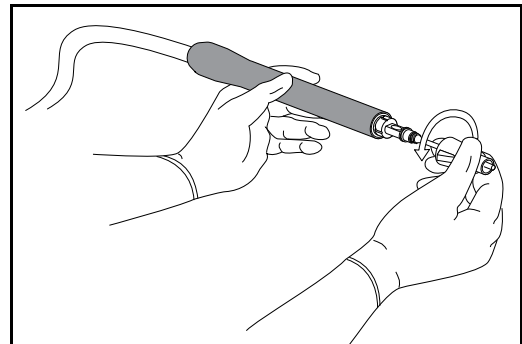

DO NOT DISCARD A STANDARD NOSECONE.

4. Remove the o-rings and discard them.

5. Locate the slot in the tip torquing base that matches the color on the handpiece connector (23 kHz – green; 36 kHz – blue). Put the handpiece in the tip torquing base so that the metal connecting body rests snugly in the metal end of the slot.

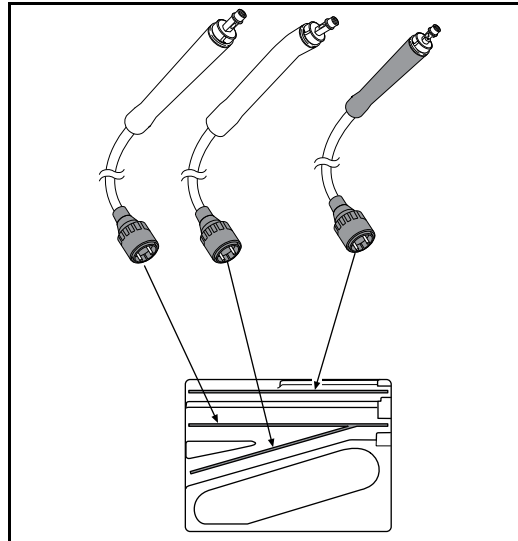

6. Hold the handpiece in place in the tip torquing base.

Caution

To avoid product damage, NEVER hold the handpiece in your hand while using the torque wrench to tighten or loosen the tip.

7. Match the colored end of the torque wrench with the handpiece color. Slide the color coded side of the wrench over the tip until the hex in the wrench engages the hex of the tip.

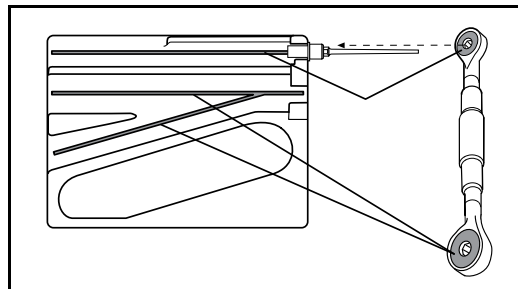

8. Rotate the wrench counterclockwise until the tip is loose.

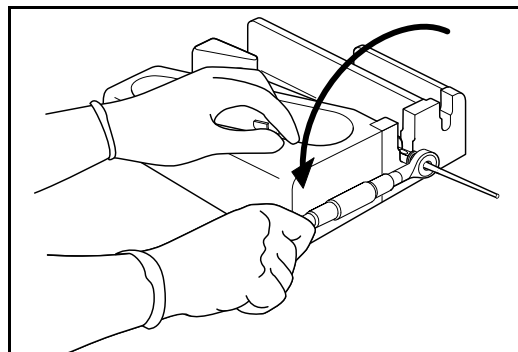

9. Remove the handpiece from the tip torquing base.

10. Unscrew the tip.

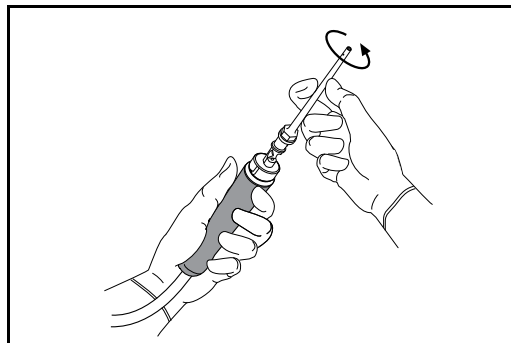

When you have disassembled the handpiece, clean the handpiece, the tip torquing base, and the torque wrench as described in the procedures below.

Cleaning the Handpiece

The handpiece can be cleaned manually or cleaned using an automatic washer.

Notice

Product damage will result if you do not follow these notices when cleaning the handpiece:

- Do not immerse the handpiece cable electrical connector in liquid.
- Do not use ultrasonic washers.
- Do not use chlorinated substances such as bleach solution.
- Do not clean the handpiece with abrasives such as Ajax[®], Comet[®], or steel wool.

Clean the Handpiece - Manual Cleaning

1. For general cleaning, using a soft cloth, manually clean the handpiece, handpiece cable, handpiece electrical connector, and standard nosecone with a mild cleansing solution (neutral detergent) or blood dissolving detergent according to hospital policy.
2. Using a soft cloth, pipe cleaner, or cotton tipped applicator, manually clean the lumen, internal threads, and face of the connecting body.

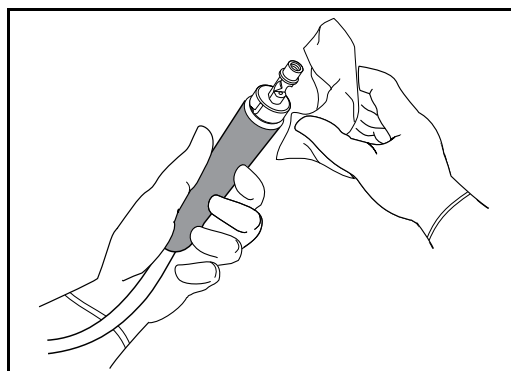

Rinse the nosecone, connecting body, handpiece housing, and handpiece cable thoroughly with clean, running water.

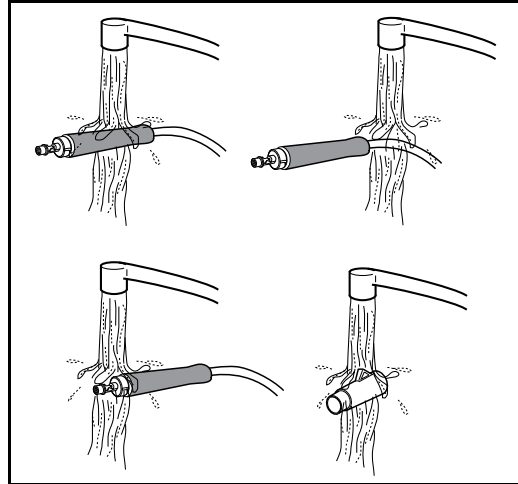

3. Manually wipe the handpiece electrical connector with a cloth moistened with water.
4. Using a soft cloth, dry the nosecone, connecting body, handpiece housing, handpiece cable, and handpiece electrical connector.

Notice

For both the handpiece and the ELT tips, to clean threads and to polish connecting surfaces, you can use the Handpiece/Tip Maintenance Kits (Ref/Cat C0023 for 23 kHz and 36 kHz).

Clean the Handpiece - Automatic Washer

Prior to the Automatic Washer cycle remove gross contaminants by wiping the handpiece with soft cloth moistened with germicidal solution.

To clean the handpiece, use a recognized medical device detergent that is pH neutral and non-enzymatic. For users in the EU the detergent should be CE Marked. Follow the instructions for use, indications, including warning and handling information provided by the detergent manufacturer.

The Handpiece cleaning process validation uses Thermoton® NR detergent, as follows:

Cleaning Stage	Attribute	Setting
Phase 1 (Pre-wash)	Pre-wash water temperature	43°C
	Pre-wash time	7 minutes
Phase 2 (main wash)	Washing temperature	55°C
	Washing hold time	5 minutes
	Detergent treatment	Thermoton® NR

Phase 3 (final rinse)	Rinsing water temperature	93°C
	Rinsing water time	5 minutes
Phase 4 (drying)	Drying temperature	98.8°C
	Drying time	20 minutes

To ensure thorough cleaning, place the handpiece on the automatic washer tray as follows:

- Put the handpiece in the center area of the tray.
- Arrange the handpiece cable in loose coils around the handpiece. Do not allow the cable to overlap.
- Position the handpiece connector so that it does not rest on the handpiece or cable.

The following is an example of correct placement of the handpiece on an automatic washer tray:



Permitted Number of Reprocessing Cycles for Handpieces when Cleaned with an Automatic Washer

The following table lists the maximum permitted number of times each handpiece can be cleaned and sterilized when using an Automatic Washer.

Handpiece	Cycles
C2602, 36kHz Straight	100 cycles or 50 hours of use, whichever comes first
C2600, 23kHz Straight	70 cycles or 50 hours of use, whichever comes first
C2601, 23kHz Angled	30 cycles or 50 hours of use, whichever comes first

Cleaning the Tip Torquing Set

Notice

Product damage will result if you do not follow these notices when cleaning the Tip Torquing Set:

- Do not use ultrasonic or automated washers
- Do not autoclave
- Do not use chlorinated substances such as bleach solution
- Do not clean with abrasives such as Ajax, Comet, or steel wool

1. Using a soft cloth and mild cleansing solution or blood dissolving detergent, manually clean the tip torquing base and the torque wrench.
2. Rinse the tip torquing base and torque wrench thoroughly with clean, running water.
3. Using a soft cloth, dry the tip torquing base and torque wrench.

Notes

Troubleshooting the System

In this section:

- For Your Information, page 14-1
- Responding to Alarms, page 14-2
- General Troubleshooting, page 14-5

For Your Information

This chapter describes troubleshooting procedures for the CUSA[®] Excel/CUSA[®] Excel+ Ultrasonic Surgical Aspirator System. It describes how to resolve an alarm on the system, and also general troubleshooting procedures

Note: To prevent tip blockage during surgery, try this. After using the tip, if you intend to set it aside for a while before using it again, flush it with saline solution. This removes debris before it can dry and block the tip while it is not in use.

Responding to Alarms

Alarm	Cause	Recommended Actions
Footswitch	Footswitch cable not properly connected to console	<p>Connect the footswitch to the console (rear panel). Turn the connector until you feel it lock into place.</p> <p>If the alarm persists after you connect the footswitch to the console, call Integra for assistance.</p>
Handpiece	Handpiece cable not properly connected to console	<p>Connect the handpiece to the console. Twist the handpiece connector clockwise until it locks into place, then verify that the yellow dots align.</p> <p>If the alarm persists after you connect the handpiece to the console, call Integra for assistance.</p>
Cooling Water	Not enough distilled water in the cooling water reservoir	Add distilled water to the cooling water reservoir up to the fill line.
	Cooling water reservoir not properly seated	Re-seat the cooling water reservoir in the console.
	A pinch or kink in the handpiece cable	Remove the pinch or kink in the cable.
	Handpiece cable not properly connected to console	Connect the handpiece to the console. Twist the handpiece connector clockwise until it locks into place, then verify that the yellow dots align.
	Damaged, misaligned, or missing o-rings in the handpiece connector	<p>Connect a new sterilized handpiece to the system, and test it for proper function.</p> <p>If the alarm persists after you connect the new handpiece to the console, call Integra for assistance.</p>
Cooling Water–On Intermittently	Possible air bubble in the handpiece cooling system	<p>The CUSA Excel/CUSA Excel+ System corrects this condition. However, if the Cooling Water alarm remains lit, refer to the condition immediately before this one: <i>Cooling Water – continuously on</i>.</p> <p>Note: If the Cooling Water alarm persists (it continues to illuminate intermittently), call Integra for assistance.</p>
	A pinch or kink in the handpiece cable	Remove the pinch or kink in the cable.

Alarm	Cause	Recommended Actions
Vibration–In Test mode only	Tip loose due to incorrect assembly	<p>Testing before sterilization:</p> <ol style="list-style-type: none"> 1. Use the tip torquing base and wrench to tighten the tip. 2. Test the tip by testing the handpiece. See Testing the Handpiece, page 5-11. 3. Sterilize the handpiece.
		<p>Testing after sterilization when tip assembled in a nonsterile area:</p> <ol style="list-style-type: none"> 1. Remove the handpiece from the sterile field. 2. Use the tip torquing base and wrench to tighten the tip. 3. Test the tip by testing the handpiece. See Testing the Handpiece, page 5-11. 4. Sterilize the handpiece.
		<p>Testing after sterile tip assembled to handpiece in the sterile field:</p> <ol style="list-style-type: none"> 1. Use the sterile torque base and a disposable sterile wrench to tighten the tip. (See Section 11: Assembling or Changing Tips in the Sterile Field) 2. Test the tip by testing the handpiece. See Testing the Handpiece, page 5-11.
	Tip contacting another object	Remove the contact with any other object.

Alarm	Cause	Recommended Actions
Vibration–In Test mode only	Blocked tip	<ol style="list-style-type: none"> 1. Verify that the manifold suction tube connects properly to the nosecone by disconnecting, then reconnecting, the tubing and its clip. 2. Use the tip cleaner to dislodge the blockage in the tip. Continue to push the tip cleaner into the tip until the cleaner becomes visible in the tubing. 3. When you have cleared the blockage, verify again that the manifold suction tube connects properly to the nosecone. 4. If the tip remains blocked, disconnect the manifold suction tube connector from the nosecone. Use the tip cleaner to dislodge blockage from the tubing, then reconnect the tubing to the nosecone. 5. Immerse the handpiece tip in sterile irrigation fluid briefly. This may clear the suction tubing.
	Damaged or cracked tip	<p>Testing before sterilization:</p> <ol style="list-style-type: none"> 1. Use the tip torquing base and wrench to replace the tip. 2. Test the tip by testing the handpiece. See Testing the Handpiece, page 5-11. 3. Sterilize the handpiece. <hr/> <p>Testing after sterilization when tip assembled in a nonsterile area:</p> <ol style="list-style-type: none"> 1. Remove the handpiece from the sterile field. 2. Use the tip torquing base and wrench to replace the tip. 3. Test the tip by testing the handpiece. See Testing the Handpiece, page 5-11. 4. Sterilize the handpiece. <hr/> <p>Testing after sterile tip assembled to handpiece in the sterile field:</p> <ol style="list-style-type: none"> 1. Use the sterile torque base and a disposable sterile wrench to replace the tip. (See Section 11: Assembling or Changing Tips in the Sterile Field) 2. Test the tip by testing the handpiece.

Alarm	Cause	Recommended Actions
Vibration–In Test mode only	Damaged handpiece	<ol style="list-style-type: none"> 1. Connect a new sterilized handpiece to the CUSA Excel/CUSA Excel+ System console and test it. 2. If the new handpiece corrects the problem: <ul style="list-style-type: none"> • Verify that the previous handpiece is correctly assembled, and • If it was correctly assembled, send it to Integra for repair. <p>If the problem persists after you replace the handpiece, call Integra for assistance.</p>

General Troubleshooting

Condition	Causes	Recommended Action
No power at the console	AC Main Switch (on the rear panel) off	Turn on the AC Main Switch (on the rear panel).
	System Power Switch (front of console) off	Turn on the System Power Switch (on the front of the console).
	Power cord not plugged in	Plug the power cord into the wall receptacle.
	Wall receptacle has no power available	Try another wall receptacle, or check the operating room circuit breakers.
	Fuse blown in plug	Change the fuse in the plug. This procedure should be performed by the hospital technician.
Power interruption to the console	Power cord becomes unplugged	<ol style="list-style-type: none"> 1. Turn off the System Power Switch (on the front of the console). 2. Plug the power cord into the wall receptacle. 3. When power is restored, turn on the System Power Switch. 4. When the Wait status indicator (flashing) turns off, press the Prime button to make sure the irrigation system is ready to use 5. Adjust the Aspiration, Irrigation, Amplitude, and Tissue Select® settings. 6. Push the Status button to change to Run mode.

Condition	Causes	Recommended Action
Power interruption in the operating room	Facility power loss	<ol style="list-style-type: none"> 1. Turn off the System Power Switch (on the front of the console). 2. When power is restored, turn on the System Power Switch. 3. When the Wait status indicator (flashing) turns off, press the Prime button to make sure the irrigation system is ready to use. 4. Adjust the Aspiration, Irrigation, Amplitude, and Tissue Select settings. 5. Push the Status button to change to Run mode.
No irrigation flow from the handpiece flue; the handpiece tip gets hot	IV administration set roller clamp closed	Open the roller clamp.
	Irrigation tubing not routed properly through irrigation pump	Route the irrigation tubing properly through the irrigation pump.
	Manifold irrigation tubing not connected to the handpiece flue tubing	Connect the Luer fitting.
	Not enough time set at Prime to allow fluid to pass through the irrigation tubing	Press the Prime button, and wait until irrigation fluid drips from the tip.
	Irrigation tubing pinched or kinked	Remove the pinch or kink from the tubing.
	IV bag empty	Replace the IV bag.
		<p>Note: For long periods of nonuse, switch the CUSA Excel/CUSA Excel+ System console to Standby mode to conserve irrigation solution.</p>
Irrigation pump not turning	Call Integra for assistance.	

Condition	Causes	Recommended Action
Excessive misting at the handpiece tip	Flue not lined up with tip pre-aspiration holes	Adjust the flue position to line up with the pre-aspiration holes in the tip. See Attach the Tip and O-rings, page 11-5.
	Too much irrigation	Reduce the irrigation rate.
	Low suction setting on the control panel	Increase the setting.
	Low or no suction due to suction tubing improperly connected to handpiece	Verify that the manifold suction tube connects properly to the nosecone by disconnecting, then reconnecting, the tubing and its clip.

Condition	Causes	Recommended Action
Excessive misting at the handpiece tip—continued	Blocked tip	<ol style="list-style-type: none"> 1. Verify that the manifold suction tube connects properly to the nosecone by disconnecting, then reconnecting, the tubing and its clip. 2. Use the tip cleaner to dislodge the blockage in the tip. Continue to push the tip cleaner into the tip until the cleaner becomes visible in the tubing. 3. When you have cleared the blockage, verify again that the manifold suction tube connects properly to the nosecone. 4. If the suction remains low, disconnect the manifold suction tube connector from the nosecone. Use the tip cleaner to dislodge blockage from the tubing, then reconnect the tubing to the nosecone. 5. Immerse the handpiece tip in sterile irrigation fluid briefly. This may clear the blockage.
	Blockage in the suction tubing at the handpiece	<ol style="list-style-type: none"> 1. Immerse the handpiece tip in sterile irrigation fluid briefly. This may clear the suction tubing. 2. Press the Status button to change to Standby mode. Use the sterile tip cleaner to clean out the tip, then put the tip in irrigating fluid to flush the tubing. 3. As necessary, disconnect, clean, and reconnect the suction tubing connector at the handpiece.
	A pinch or kink in the suction tubing	Straighten the tubing to remove a kink, or remove anything that might pinch the tube.
	A blockage in the suction tubing between the handpiece and the suction canister	<ol style="list-style-type: none"> 1. Examine the suction tubing along its entire length for a blockage. 2. Squeeze the blocked area to loosen it. 3. Immerse the handpiece tip in sterile irrigation fluid briefly. This may clear the blockage.
	Suction canister full	Replace the suction canister.

Condition	Causes	Recommended Action	
Excessive misting at the handpiece tip—continued	Suction connections at the suction canister not seated properly	<ol style="list-style-type: none"> 1. Remove any unused suction canister “elbow” connectors. 2. Reseat all connections. 	
	Open port(s) on the suction canister	Close any open ports on the suction canister.	
	Suction canister improperly connected	Refer to the canister manufacturer’s instructions for connecting the canister.	
	Inside of the contamination guard wet and blocked		<ol style="list-style-type: none"> 1. Disconnect the contamination guard fitting from the suction canister tubing. If you feel no suction at the end of the contamination guard fitting, the guard is blocked. 2. Replace the contamination guard.
			Problem at the CUSA Excel/CUSA Excel+ System console suction port
	Suction pinch valve not working properly	<p>Check the Lap mode indicator.</p> <ul style="list-style-type: none"> • If Lap mode is off, in Run mode the pinch valve should be open. • If Lap mode is on, in Run mode the pinch valve should be open only when you activate vibration. <p>If these conditions do not exist, call Integra for assistance.</p>	
The Run mode status indicator does not illuminate when you activate vibration.	System in Standby mode	Press the Status button to switch the system to Run mode.	

Condition	Causes	Recommended Action
Little or no vibration or fragmentation (Amplitude setpoint indicators may illuminate well below setpoint)	Excessive tip/tissue pressure (stalling tip)	1. Verify that console settings are at desired levels. 2. Remove the tip from contact with tissue, then reactivate vibration. Note: When first activating vibration, make sure that there is no tip/tissue pressure.
	Blocked tip	1. Verify that the manifold suction tube connects properly to the nosecone by disconnecting, then reconnecting, the tubing and its clip. 2. Use the tip cleaner to dislodge the blockage in the tip. Continue to push the tip cleaner into the tip until the cleaner becomes visible in the tubing. 3. When you have cleared the blockage, verify again that the manifold suction tube connects properly to the nosecone. 4. If the tip remains blocked, disconnect the manifold suction tube connector from the nosecone. Use the tip cleaner to dislodge blockage from the tubing, then reconnect the tubing to the nosecone. 5. Immerse the handpiece tip in sterile irrigation fluid briefly. This may clear the suction tubing.
	Incorrect flue installed	Install the correct flue.

Condition	Causes	Recommended Action
<p>Little or no vibration or fragmentation (Amplitude setpoint indicators may illuminate well below setpoint)—continued</p>	<p>Tip loose due to improper assembly</p>	<ol style="list-style-type: none"> 1. Press the Status button to place the system in Standby mode. 2. Press the Test button to test the handpiece and tip. 3. If the Vibration alarm activates, do one of the following: <ul style="list-style-type: none"> If tip assembled in a nonsterile area: <ul style="list-style-type: none"> • Remove the handpiece from the sterile field. • Use the tip torquing base and wrench to tighten the tip. • Test the tip by testing the handpiece. • Sterilize the handpiece. If sterile tip assembled to handpiece in the sterile field: <ul style="list-style-type: none"> • Use the sterilizable torque base and a disposable sterile wrench to tighten the tip. (See Section 11: Assembling or Changing Tips in the Sterile Field)Test the tip by testing the handpiece.
	<p>Console not left in Run mode for a minimum of two continuous minutes (36 kHz handpiece only).</p>	<ol style="list-style-type: none"> 1. Return to Standby mode. 2. Restart Run mode and wait for two minutes before using the system.

Condition	Causes	Recommended Action
Little or no vibration or fragmentation (Amplitude setpoint indicators may illuminate well below setpoint)—continued	<p>Damaged or cracked tip</p> <hr/> <p>Damaged handpiece</p>	<ol style="list-style-type: none"> 1. Press the Status button to place the system in Standby mode. 2. Press the Test button to test the handpiece and tip. 3. If the Vibration alarm activates, do one of the following: <ul style="list-style-type: none"> If tip assembled in a nonsterile area: <ul style="list-style-type: none"> • Remove the handpiece from the sterile field. • Use the tip torquing base and wrench to replace the tip. • Test the tip by testing the handpiece. • Sterilize the handpiece. If sterile tip assembled to handpiece in the sterile field: <ul style="list-style-type: none"> • Use the sterilizable torque base and a disposable sterile wrench to replace the tip. (See Section 11: Assembling or Changing Tips in the Sterile Field) • Test the tip by testing the handpiece. <hr/> <ol style="list-style-type: none"> 1. Connect a new handpiece to the CUSA Excel/CUSA Excel+ console and test it. 2. If the new handpiece corrects the problem, <ul style="list-style-type: none"> • Verify that the previous handpiece is correctly assembled, and • If it was correctly assembled, send it to Integra for repair. <p>If the problem persists after you replace the handpiece, call Integra for assistance.</p>
Suction tube won't assemble correctly to handpiece nosecone	<p>Nosecone not assembled to handpiece correctly</p> <hr/> <p>Transducer is twisted inside handpiece housing</p>	<p>Align the dot on the nosecone with the dot on the handpiece.</p> <hr/> <p>Replace with a sterilized handpiece.</p>

Condition	Causes	Recommended Action	
Low suction at the handpiece tip	Low suction setting on the control panel	Increase the setting.	
	System inadvertently in Lap mode	Turn off the Lap mode by pressing the Lap mode button.	
	Suction tubing improperly connected to handpiece	Verify that the manifold suction tube connects properly to the nosecone by disconnecting, then reconnecting, the tubing and its clip.	
	Blocked tip	<ol style="list-style-type: none"> 1. Verify that the manifold suction tube connects properly to the nosecone by disconnecting, then reconnecting, the tubing and its clip. 2. Use the tip cleaner to dislodge the blockage in the tip. Continue to push the tip cleaner into the tip until the cleaner becomes visible in the tubing. 3. When you have cleared the blockage, verify that the manifold suction tube connects properly to the nosecone. 4. If the suction remains low, disconnect the manifold suction tube connector from the nosecone. Use the tip cleaner to dislodge blockage from the tubing, then reconnect the tubing to the nosecone. 5. Immerse the handpiece tip in sterile irrigation fluid briefly. This may clear the blockage. 	
Blockage in the suction tubing at the handpiece		<ol style="list-style-type: none"> 1. Immerse the handpiece tip in sterile irrigation fluid briefly. This may clear the suction tubing. 2. Press the Status button to change to Standby mode. Use the sterile tip cleaner to clean out the tip, then put the tip in irrigating fluid to flush the tubing. 3. As necessary, disconnect, clean, and reconnect the suction tubing connector at the handpiece. 	
A pinch or kink in the suction tubing		Straighten the tubing to remove a kink, or remove anything that might pinch the tube.	

Condition	Causes	Recommended Action
Low suction at the handpiece tip—continued	A blockage in the suction tubing between the handpiece and the suction canister	<ol style="list-style-type: none"> 1. Examine the suction tubing along its entire length for a blockage. 2. Squeeze the blocked area to loosen it. 3. Immerse the handpiece tip in sterile irrigation fluid briefly. This may clear the blockage.
	Suction canister full	Replace the suction canister.
	Suction connections at the suction canister not seated properly	<ol style="list-style-type: none"> 1. Remove any unused suction canister “elbow” connectors. 2. Reseat all connections.
	Open port(s) on the suction canister	Close any open ports on the suction canister.
	Suction canister improperly connected	Refer to the canister manufacturer’s instructions for connecting the canister.
	Inside of the contamination guard wet, blocked, or both	<ol style="list-style-type: none"> 1. Disconnect the contamination guard fitting from the suction canister tubing. If you feel no suction at the end of the contamination guard fitting, the guard is blocked. 2. Replace the contamination guard.
	Problem at the console suction port	Remove the contamination guard and put a finger in the suction system port. If you feel no suction, call Integra for assistance.
Suction pinch valve working improperly	<p>Check the Lap mode indicator.</p> <ul style="list-style-type: none"> • If Lap mode is off, in Run mode the pinch valve should be open. • If Lap mode is on, in Run mode the pinch valve should be open only when you activate vibration. <p>If these conditions do not exist, call Integra for assistance.</p>	

Condition	Causes	Recommended Action
The handpiece gets hot	Surgeon holding handpiece at tip and flue	Hold the handpiece at the nosecone.
	Handpiece damage due to tip torquing without the torque base	Replace with a sterilized handpiece.
	Loss of cooling water at the handpiece	Check the Cooling Water System. If problem persists, return handpiece for service.
The nosecone is loose	Large o-ring not installed correctly, or missing	Install the large o-ring in the proper position on the handpiece.
	Nosecone worn	Replace with a sterilized nosecone.

Notes

Maintaining the System

In this section:

- For Your Information, page 15-1
- Quick Reference, page 15-2
- Handpiece Maintenance, page 15-3
- Sterilizer Case Maintenance, page 15-4
- Handling and Transporting of the System, page 15-4
- Storage of the System and Accessories, page 15-5
- Disposal of the Equipment, page 15-5
- Return Equipment for Service, page 15-5
- Integra Service Centers, page 15-7

For Your Information

This chapter describes routine maintenance tasks for the system. Biomedical Engineering at your facility should perform these tasks.

It also describes handling and storage information for the system, and information on returning equipment to Integra for service.

Quick Reference

The following chart lists routine maintenance tasks, when you perform each task, and the equipment on which you perform them.

Table 15-1

Routine maintenance tasks for CUSA[®] Excel/CUSA[®] Excel+ System

When	Equipment	Task
Daily or when used	CUSA Excel/CUSA Excel+ console	Disinfect and wipe dry.
Daily or when used	Cooling Water Reservoir	Discard water from the reservoir.
Daily or when used	Footswitch	<ol style="list-style-type: none"> 1. Discard the footswitch cover (if using). 2. Clean the footswitch.
Every 3 months, or every 12 to 15 procedures, whichever comes first	Console	Fill the cooling water reservoir with a solution consisting of 100 ml of 70% alcohol and 900 ml of water. Connect the handpiece, then turn on the system. Allow the system to run a few cooling cycles to clean the interior tubing. Turn off the system. Discard the alcohol solution, then fill the reservoir with distilled water. Turn on the system, and allow it to cycle the water to remove the alcohol solution from the tubing.
Every 6 months, or when filter changes color	Console	Replace the contamination guard. Write either the installation date or the expiration date on the guard.
Once a year	Console – Cooling Water Tubing	Contact an Integra service representative to replace the cooling water pump tubing.
Once a year	Console – Control Arm Gasket	Contact an Integra service representative to replace the control arm gasket.
After 50 hours of use, or 100 surgical procedures, whichever comes first	Handpiece	Return handpiece for service.
Every month or 80 hours of use	Handpiece	Apply a high viscosity lubricant to the handpiece connector o-rings.
Every 6 months or 500 hours of use	Handpiece	Replace the handpiece connector o-rings.

Handpiece Maintenance

Maintaining the handpiece involves lubricating the handpiece connector o-rings or replacing the handpiece connector o-rings.

Permitted Number of Reprocessing Cycles for Handpieces when Cleaned with an Automatic Washer

The following table lists the maximum permitted number of times each handpiece can be cleaned and sterilized when using an Automatic Washer.

Handpiece	Cycles
C2602, 36kHz Straight	100 cycles or 50 hours of use, whichever comes first
C2600, 23kHz Straight	70 cycles or 50 hours of use, whichever comes first
C2601, 23kHz Angled	30 cycles or 50 hours of use, whichever comes first

Recalibrate the Handpiece

It is recommended that you return the handpiece for service after 50 hours of use, or 100 surgical procedures, whichever comes first.

It is recommended that you retain a spare handpiece in the sterile field. Contact Integra to arrange returning the handpiece for service. (See "Return Equipment for Service" on page 15-5.)

Lubricate the Handpiece Connector O-Rings

Keeping the o-rings lubricated prevents them from drying out and cracking, which may cause handpiece cooling problems.

Frequency: Every month or every 80 hours of use, whichever comes first.

Items needed: A high viscosity lubricant such as silicone grease.

Items to be lubricated: The four o-rings on the handpiece connector water prongs.

Replace the Handpiece Connector O-Rings

Regularly replacing the o-rings prevents excessive wear, which may result in handpiece cooling problems.

Frequency: Every six months or 500 hours of use, whichever comes first.

Items needed: O-Ring maintenance kit, which includes o-rings, an insertion tool, and instructions.

Figure 15-1 Replacing o-ring on the handpiece connector water prongs

Items to be replaced: The four o-rings on the handpiece connector water prongs.

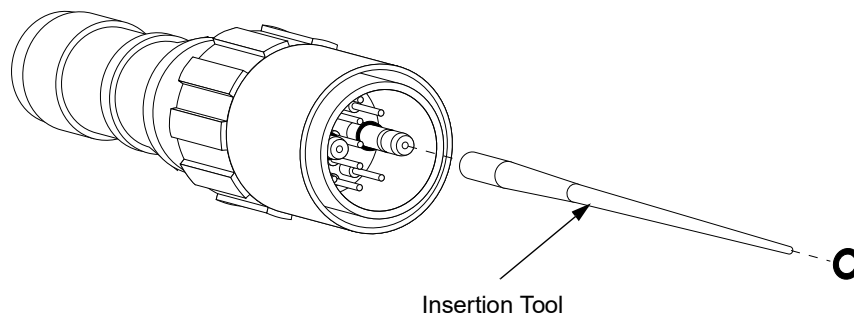

Sterilizer Case Maintenance

Use a neutral detergent to clean the sterilizer case.

Notice

Do not clean the sterilizer case with abrasives. Product damage will result.

Handling and Transporting of the System

If you need to move/relocate the CUSA Excel/CUSA Excel+ System within the environment of the Healthcare Facility, note the guidelines below.

Before moving the console:

- Unplug the power cord from the wall receptacle and place the power cord in the storage compartment at the rear of the console.
- Disconnect the handpiece.
- Disconnect and remove the irrigation fluid.
- Retract the IV pole.
- Secure any loose objects. Make sure there are no loose objects placed on the top of the console.
- Secure the footswitch cord on cord wraps provided on the back of the console and place the footswitch in the storage compartment at the rear of the console.
- Adjust the control panel to its lowest height. Make sure the control panel is locked into position.

When moving the console:

- Push the console using the handle; don't pull it.

- Do not run whilst pushing the console.
- Use a lift to move the console between floors of a building. Never use a stairwell.
- Do not attempt to lift the console.

To move the console up or down a ramp, use two or more people.

The CUSA Excel/CUSA Excel+ System requires a minimum of one hour exposure at its operating temperature range before you use it; make sure that the system is located in the surgical room at least an hour before use.

Storage of the System and Accessories

Console

Drain all liquids. Make sure the system is clean. Store the system in a low traffic area that is free of dirt, blood, water, and other contaminants. Store the system at an ambient temperature between -34°C and 65°C.

Handpiece

Drain all liquids. Store the handpiece in the sterilizer case according to your facility's policy.

Store the handpiece at an ambient temperature between -34°C and 65°C.

Footswitch

You do not need to disconnect the footswitch from the console except for maintenance or service. When you are not using the CUSA Excel/CUSA Excel+ System, secure the footswitch cord on cord wraps provided on the back of the console and store the footswitch in the storage compartment in the rear of the console.

Disposal of the Equipment

The CUSA Excel family of consoles, handpieces and footswitches are considered electrical equipment and must be disposed of in accordance with regional regulations hospital protocols.

Return Equipment for Service

Before you return CUSA Excel/CUSA Excel+ equipment, call your Integra representative for help. If the representative tells you to send the equipment to Integra, first obtain a Return Authorization Number. Then clean the equipment and ship it to Integra for service.

Obtaining a Return Authorization Number

Call the Integra Service Center for your area (refer to *Integra Service Centers* in this section) to obtain a Return Authorization Number. Have the following information ready when you call:

- Hospital/clinic name/customer number
- Technician's name
- Telephone number
- Department/address, city, state, and zip or postal code
- Model number
- Serial number
- Description of the problem
- Type of repair to be done (if known)

Attach a tag with this same information to the equipment when you ship it for service.

Returning the Console

Notice

To avoid product damage, use proper packaging materials and packing procedures when preparing the console for shipment. Failure to return product in this manner may void your warranty.

For instructions on packing the console properly, contact your Integra representative.

Returning Handpieces

Clean, disinfect, and sterilize a handpiece before you package it for shipping.

Package a handpiece to protect the handpiece and handpiece cable connector from damage.

Package each handpiece in a separate packaging container.

Ordering Replacement Parts

The following replacement parts may be ordered from Integra:

- Cooling Water Reservoir (S202750115)
- O-Ring Maintenance Kit (S200700120)

When ordering replacement parts for equipment, include this information:

- Model number (located on the CUSA Excel/CUSA Excel+ System rear panel)
- Serial number (located on the CUSA Excel/CUSA Excel+ System rear panel)

Integra Service Centers

US Service Center

Integra LifeSciences

4900 Charlemar Drive Dock B

Cincinnati, Ohio 45227

Phone: 877-444-1114

Email: Integra-Service@integralife.com

Europe, Middle East and Africa Service Center

Integra GmbH

Borsigstraße 11-15

40880 Ratingen

Germany

Tel: +49 2102 5535 6150

Fax: +49 2102 942 4872

E-mail: emea.techservice@integralife.com

Asia Pacific Service Center

Integra NeuroSciences Pty Ltd

Warehouse 3, 24-30 Winterton Road,

Clayton, VIC 3168, Australia

Phone: +61 3 8540 0400

Email: service.au@integralife.com

<https://www.integralife.com/contactUsAustralia>

Notes

Technical Specifications

Console Dimensions

CUSA[®] Excel/CUSA[®] Excel+ Console

Height	132 cm (52 in)
Width	55.88 cm (22 in)
Depth	71.12 cm (28 in)
Weight	93 kg (200 lbs)

Footswitch

Height	5.08 cm (2 in)
Width	30.48 cm (12 in)
Cable length	4.575 m (15 ft)

Console Subsystems

Ultrasonic

Frequency (23kHz)	23 kHz (nominal frequency)
Frequency (36kHz)	35.67 - 35.83 kHz (frequency range)
Maximum Tip Amplitude (23 kHz)	Up to 355 microns for straight handpiece Up to 183 microns for angled handpiece
Maximum Tip Amplitude (36 kHz)	Up to 210 microns

Fluidic System

Cooling System	Cooling water flow is 35 – 50 ml/min.
Irrigation Rate	The irrigation rate display shows digits 1 – 10 The irrigation rate is approximately 1 – 10 ml/min., normal; greater than 25 ml/min., Fast Flush
Suction System	Up to 660 mm (26 inches) mercury at the pump intake at sea level The suction level will be lower at higher altitudes.

Electrical Requirements

Input Power Source

Power Ratings	<p>The CUSA Excel/CUSA Excel+ System operates on one of the following voltage ranges:</p> <p>220–240 Volt</p> <p>95–120 Volt</p> <p>950–1200 VA (All 4 Models)</p> <p>The voltage range is specified on the serial number label on the console.</p> <p>Line fusing resides in fuse receptacles on the rear panel. The fuse values are:</p> <ul style="list-style-type: none"> • For 220–240 Volt operation: T5A. • For 95–120 Volt operation: T10A.
Frequencies	<p>50 Hz \pm 2 Hz</p> <p>60 Hz \pm 2 Hz</p>
Breaking Capacity	<p>T5A: Low</p> <p>T10A: Low</p>

Power Cords

Cord	Harmonized type three conductor cord or UL listed 3-conductor.
Connector	Integra provides a connector approved for the region in which your country is geographically located. Refer to the Plug IFU supplied in the console carton.

If a facility intends to use the CUSA Excel/CUSA Excel+ System in an operating room with another type of receptacle, the facility is responsible for replacing the connector on the power cord. The replacement connector must be properly grounded.

Warning

Explosion Hazard – Do not use the CUSA Excel/CUSA Excel+ System in the presence of flammable anesthetics or any potentially explosive or flammable atmosphere.

Warning

TO AVOID RISK OF ELECTRIC SHOCK, THIS EQUIPMENT MUST ONLY BE CONNECTED TO A SUPPLY MAINS WITH PROTECTIVE EARTH.

Warning

The console must be earthed, and therefore it **MUST** only be fitted with a 3-pin plug, or a 2-pin plug that has an integral earth grounding connection. Mains plug type and construction **MUST** comply with Legal requirements within country of installation. Only Integra Service personnel or Integra authorized representatives or agents can change the mains plug on the console.

Low Frequency Leakage

Touch current <100µA

Patient leakage current <100µA

Duty Cycle

Under maximum loading conditions, the CUSA Excel/CUSA Excel+ console is suitable for ultrasonics activation times of 10 minutes on, 5 minutes off.

Environment



Operating temperature range 10°C (50°F) to 35°C (95°F)



Operating humidity range 15 to 80%, relative humidity, non-condensing

Operating atmospheric pressure range 70 kPa to 106 kPa



Storage and shipping temperature -34°C (-29°F) to 65°C (149°F)



Storage and shipping humidity 25 to 85% relative humidity, non-condensing

The system requires a minimum of one hour exposure at its operating temperature range before you use it.

See section EMC Compatibility on page A-5 for further information on environmental conditions.

Electromagnetic Interference

The CUSA Excel/CUSA Excel+ System console minimizes electromagnetic interference to other equipment used in the operating room. The system complies with the requirements of IEC 60601-1-2:2007.

Note that other devices in the operating room may generate electromagnetic interference. Use caution in locating equipment within the room to reduce the electromagnetic interference.

Voluntary Standards

The CUSA Excel/CUSA Excel+ System meets the following standards:

- **IEC 60601-1:2005** Medical electrical equipment: General requirements for basic safety and essential performance
- **cUL/CSA** Test requirements: (CSA 22.2, No. 601.1.8)
- **IEC 60601-1-6:2005** Medical electrical equipment: General requirements for basic safety and essential performance. Collateral Standard: Usability
- **IEC 60601-1-2:2005** Medical electrical equipment: General requirements for basic safety and essential performance. Collateral standard: Electromagnetic compatibility - Requirements and tests
- **CISPR11** Electromagnetic compatibility for industrial-process measurement and control equipment: Emissions requirements
- **ISTA** Pre-Shipment Test Procedures

Statutory and Regulatory Classification

Class II (FDA) Medical Device (General Controls and Special Controls)

Class IIb (EU)

Class III (EU)

Class 4 (Canada)

EMC Compatibility

Notice

The CUSA Excel/CUSA Excel+ System should not be used adjacent to or stacked with equipment other than the equipment specified in the CUSA Excel/CUSA Excel+ System User Guide. If adjacent or stacked use is necessary, the CUSA Excel/CUSA Excel+ System should be observed to verify normal operation in the configuration in which it will be used.

The use of accessories, other than the accessories specified in the CUSA Excel/CUSA Excel+ System User Guide may result in increased emissions or decreased immunity of the CUSA Excel/CUSA Excel+ System.

Guidance and Manufacturer's Declarations

Guidance and manufacturer's declaration – electromagnetic emissions		
<p>The CUSA Excel/CUSA Excel+ System is intended for use in the electromagnetic environment specified below. The customer or the user of the CUSA Excel/CUSA Excel+ System should assure that it is used in such an environment.</p>		
Emissions test	Compliance	Electromagnetic environment - Guidance
RF emissions CISPR 11	Group 1	The CUSA Excel/CUSA Excel+ System uses RF energy only for its internal function. Therefore, its RF emissions are very low and are not likely to cause any interference in nearby electronic equipment. The CUSA Excel/CUSA Excel+ System is suitable for use in all establishments other than domestic and those directly connected to the public low-voltage power supply network that supplies buildings used for domestic purposes.
RF emissions CISPR 11	Class A	
Harmonics emissions IEC 61000-3-2	Class A	
Voltage fluctuations / flicker emissions IEC 61000-3-3	Complies	

Guidance and manufacturer's declaration – electromagnetic immunity			
The CUSA Excel/CUSA Excel+ System is intended for use in the electromagnetic environment specified below. The customer or the user of the CUSA Excel/CUSA Excel+ System should assure that it is used in such an environment.			
IMMUNITY Test	IEC 60601 test level	Compliance level	Electromagnetic environment - Guidance
Electrostatic discharge (ESD) IEC 61000-4-2	± 6 kV contact ± 8 kV air	± 6 kV contact ± 8 kV air	Floors should be wood, concrete or ceramic tile. If floors are covered with synthetic material, the relative humidity should be at least 30 %.
Electrical fast transient/burst IEC 61000-4-4	± 2 kV for power supply lines ± 1 kV for input/output lines	± 2 kV for power supply lines ± 1 kV for input/output lines	Mains power quality should be that of a typical commercial or hospital environment.
Surge IEC 61000-4-5	± 1 kV line(s) to line(s) ± 2 kV line(s) to earth	± 1 kV line(s) to line(s) ± 2 kV line(s) to earth	Mains power quality should be that of a typical commercial or hospital environment.
Voltage dips, short interruptions and voltage variations on power supply input lines. IEC 61000-4-11	<5 % U_T (>95 % dip in U_T) for 0,5 cycle <40 % U_T (>60 % dip in U_T) for 5 cycles <70 % U_T (>30 % dip in U_T) for 25 cycles <5 % U_T (>95 % dip in U_T) for 5 s	<5 % U_T (>95 % dip in U_T) for 0,5 cycle <40 % U_T (>60 % dip in U_T) for 5 cycles <70 % U_T (>30 % dip in U_T) for 25 cycles <5 % U_T (>95 % dip in U_T) for 5 s	Mains power quality should be that of a typical commercial or hospital environment. If the user of the CUSA Excel/CUSA Excel+ System requires continued operation during power mains interruptions, it is recommended that the CUSA Excel/CUSA Excel+ System be powered from an uninterruptible power supply or a battery.
Power frequency (50/60 Hz) magnetic field IEC 61000-4-8	3 A/m	3 A/m	Power frequency magnetic fields should be at levels characteristic of a typical location in a typical commercial or hospital environment.
NOTE U_T is the a.c. mains voltage prior to application of the test level.			

Guidance and manufacturer's declaration – electromagnetic immunity			
The CUSA Excel/CUSA Excel+ System is intended for use in the electromagnetic environment specified below. The customer or the user of the CUSA Excel/CUSA Excel+ System should assure that it is used in such an environment.			
IMMUNITY Test	IEC 60601 test level	Compliance level	Electromagnetic environment -Guidance
Conducted RF IEC 61000-4-6	3 Vrms 150 kHz to 80 MHz	3 Vrms	<p>Portable and mobile RF communications equipment should be used no closer to any part of the CUSA Excel/CUSA Excel+ System, including cables, than the recommended separation distance calculated from the equation applicable to the frequency of the transmitter.</p> <p>Recommended separation distance</p> $d = 1,2\sqrt{P}$ <p>$d = 1,2\sqrt{P}$ 80 MHz to 800 MHz</p> <p>$d = 2,4\sqrt{P}$ 800 MHz to 2,5 GHz</p>
Radiated RF IEC 61000-4-3	3 V/m 80 MHz to 2,5 GHz	3 V/m	<p>Where P is the maximum output power rating of the transmitter in watts (W) according to the transmitter manufacturer and d is the recommended separation distance in meters (m).</p> <p>Field strengths from fixed RF transmitters, as determined by an electromagnetic site survey^a, should be less than the compliance level in each frequency range^b.</p> <p>Interference may occur in the vicinity of equipment marked with the following symbol:</p> 

NOTE 1 At 80 MHz and 800 MHz, the higher frequency range applies.

NOTE 2 These guidelines may not apply in all situations. Electromagnetic propagation is affected by absorption and reflection from structures, objects and people.

^a Field strengths from fixed transmitters, such as base stations for radio (cellular/cordless) telephones and land mobile radios, amateur radio, AM and FM radio broadcast and TV broadcast cannot be predicted theoretically with accuracy. To assess the electromagnetic environment due to fixed RF transmitters, an electromagnetic site survey should be considered. If the measured field strength in the location in which the CUSA Excel/CUSA Excel+ System is used exceeds the applicable RF compliance level above, the CUSA Excel/CUSA Excel+ System should be observed to verify normal operation. If abnormal performance is observed, additional measures may be necessary, such as re-orientating or relocating the CUSA Excel/CUSA Excel+ System.

^b Over the frequency range 150 kHz to 80 MHz, field strengths should be less than 3 V/m.

Recommended separation distances between portable and mobile RF communications equipment and the CUSA Excel/CUSA Excel+ System			
<p>The CUSA Excel/CUSA Excel+ System is intended for use in an electromagnetic environment in which radiated RF disturbances are controlled. The customer or the user of the CUSA Excel/CUSA Excel+ System can help prevent electromagnetic interference by maintaining a minimum distance between portable and mobile RF communications equipment (transmitters) and the CUSA Excel/CUSA Excel+ System as recommended below, according to the maximum output power of the communications equipment.</p>			
Rated maximum output power of transmitter W	Separation distance according to frequency of transmitter m		
	150 kHz to 80 MHz $d = 1,2\sqrt{P}$	80 MHz to 800 MHz $d = 1,2\sqrt{P}$	800 MHz to 2,5 GHz $d = 2,4\sqrt{P}$
0.01	0.12 m	0.12 m	0.24 m
0.1	0.38 m	0.38 m	0.76 m
1	1.2 m	1.2 m	2.4 m
10	3.8 m	3.8 m	7.6 m
100	12 m	12 m	24 m
<p>For transmitters rated at maximum output power not listed above, the recommended separation distance d in metres (m) can be estimated using the equation applicable to the frequency of the transmitter, where P is the maximum output power rating of the transmitter in watts (W) according to the transmitter manufacturer.</p> <p>NOTE 1 At 80 MHz and 800 MHz, the separation distance for the higher frequency range applies.</p> <p>NOTE 2 These guidelines may not apply in all situations. Electromagnetic propagation is affected by absorption and reflection from structures, objects and people.</p>			

Handpieces

Nominal Frequencies

23 kHz Straight	23 kHz
23 kHz Angled	23 kHz
36 kHz Straight	35.75 kHz

Dimensions

23 kHz Straight

Length	22.2 cm (8.74 in)
Diameter	2.08 cm (0.82 in)

23 kHz Angled

Length	22.2 cm (8.74 in)
Diameter	2.08 cm (0.82 in)

36 kHz Straight

Length	13.9 cm (5.47 in)
Diameter	1.64 cm (0.65 in)

Tip Specifications

Table A-1 on page A-12 shows specifications for tips that attach to the 23 kHz handpiece.

Table A-2 on page A-13 shows specifications for tips that attach to the 36 kHz handpiece.

Tip Specifications for 23 kHz Handpiece

Table A-1
Tip Specifications—23 kHz

Tip	Length (mm) [in]	ID (mm) [in]	OD (mm) [in]	Amplitude (peak to peak) (μ m) [in]	Weight (g)
Standard Tip	79.8 [3.140]	1.98 [0.078]	2.54 [0.100]	Straight Handpiece: 287 to 355 [0.0113 to 0.0140] Angled Handpiece: 112 to 163 [0.0044 to 0.0064]	3.54
MicroTip™	92.2 [3.630]	1.57 [0.062]	1.93 [0.076]	Straight Handpiece: 279 to 355 [0.0110 to 0.0140] Angled Handpiece: 127 to 183 [0.005 to 0.0072]	3.99
Straight Extended Standard Tip	183.8 [7.238]	1.98 [0.078]	2.54 [0.100]	Straight Handpiece: 287 to 355 [0.0113 to 0.0140] Angled Handpiece: 112 to 163 [0.0044 to 0.0064]	16.15
Curved Extended Standard Tip	183.8 [7.238]	1.98 [0.078]	2.54 [0.100]	Straight Handpiece: 287 to 355 [0.0113 to 0.0140] Not compatible with angled handpiece	16.15
MacroTip™	79.5 [3.130]	2.64 [0.104]	3.18 [0.125]	Straight Handpiece: 254 to 307 [0.0100 to 0.0121] Angled Handpiece: 102 to 142 [0.0040 to 0.0056]	3.84
Laparoscopic Tip	301.4 [11.865]	1.98 [0.078]	2.54 [0.100]	Straight Handpiece: 178 to 229 [0.007 to 0.009] Not compatible with angled handpiece	32.13
Extended Life Standard Tip ^a	79.8 [3.140]	1.98 [0.078]	2.54 [0.100]	Straight Handpiece: 287 to 355 [0.0113 to 0.0140] Angled Handpiece: 112 to 163 [0.0044 to 0.0064]	3.54
Extended Life MacroTip ^b	79.5 [3.130]	2.64 [0.104]	3.18 [0.125]	Straight Handpiece: 254 to 307 [0.0100 to 0.0121] Angled Handpiece: 102 to 142 [0.0040 to 0.0056]	3.84

a. Not for sale within USA.

b. Not for sale within USA.

Tip Specifications for the 36 kHz Handpiece

Table A-2
Tip Specifications—36 kHz

Tip	Length (mm) [in]	ID (mm) [in]	OD (mm) [in]	Amplitude (peak to peak) (μ m) [in]	Weight (g)
PrecisionTip™	56.4 [2.221]	1.14 [0.045]	1.45 [0.057]	191 to 210 [0.0075 to 0.0083]	1.37
Straight Extended PrecisionTip	125.1 [4.924]	1.14 [0.045]	1.45 [0.057]	191 to 210 [0.0075 to 0.0083]	7.86
Curved Extended PrecisionTip	125.1 [4.924]	1.14 [0.045]	1.45 [0.057]	191 to 210 [0.0075 to 0.0083]	7.86
MicroTip™	52.8 [2.080]	1.57 [0.062]	1.93 [0.076]	175 to 193 [0.0069 to 0.0076]	1.30
Straight Extended MicroTip	121.5 [4.783]	1.57 [0.062]	1.93 [0.076]	175 to 193 [0.0069 to 0.0076]	7.50
Curved Extended MicroTip	121.5 [4.783]	1.57 [0.062]	1.93 [0.076]	175 to 193 [0.0069 to 0.0076]	7.50
Extended MicroTip Plus	192.7 [7.588]	1.57 [0.062]	1.93 [0.076]	137 to 155 [0.0054 to 0.0061]	7.97
Standard Tip	45.7 [1.800]	1.98 [0.078]	2.54 [0.100]	137 to 155 [0.0054 to 0.0061]	1.31
Straight Extended Standard Tip	114.4 [4.504]	1.98 [0.078]	2.54 [0.100]	137 to 155 [0.0054 to 0.0061]	7.48
Curved Extended Standard Tip	114.4 [4.504]	1.98 [0.078]	2.54 [0.100]	137 to 155 [0.0054 to 0.0061]	7.48
CUSA® SaberTip™	114.9 [4.525]	1.14 [0.45]	2.23 [0.088]	117 to 135 [0.0046 to 0.0053]	9.55
CUSA® ShearTip™	117.9 [4.643]	1.57 [0.062]	2.33 [0.0919]	165 to 203 [0.0065 to 0.0080]	7.77
Extended Life Curved Extended PrecisionTip ^a	125.1 [4.924]	1.14 [0.45]	1.45 [0.057]	175 to 210 [0.0069 to 0.0083]	7.86
Extended Life Curved Extended MicroTip ^b	121.5 [4.783]	1.57 [0.062]	1.93 [0.076]	165 to 193 [0.0065 to 0.0076]	7.50
Extended Life Curved Extended Standard Tip ^c	114.4 [4.504]	1.98 [0.078]	2.54 [0.100]	137 to 155 [0.0054 to 0.0061]	7.48

a. Not for sale within USA.

b. Not for sale within USA.

c. Not for sale within USA.

Notes

Sterilization Validation

Validation of Steam Sterilization Parameters

A steam sterilization study was conducted according to AAMI TIR No. 12-2010– Designing, Testing, and Labeling Reusable Medical Devices for Reprocessing in Health Care Facilities: A Guide for Device Manufacturers.

Challenge

A minimum of 1×10^6 bacillus stearothermophilus on a spore strip/disk carrier and a braided nylon suture carrier. ($D_{121^\circ\text{C}} = 1.5$ and 1.6 minutes).

Placement of Biological Indicators (BIs)

CUSA 23 kHz Handpiece, Tip and Tubing:

Cycles contained four BIs (spore suture) placed in the following locations:

- Inside the tip, not assembled to the hand piece
- Wrapped around the handpiece cord
- Underneath the tip torquing base where it meets the bottom of the case
- Approximately half way inside the manifold tubing

CUSA 36 kHz Handpiece, Tip and Tubing:

Cycles contained four BIs (spore suture) placed in the following locations:

- Inside the tip when assembled to the handpiece
- Wrapped around the handpiece cord
- Underneath the tip torquing base where it meets the bottom of the case
- Approximately half way inside the manifold tubing

Acceptance Criteria

In order for the handpiece to be considered validated, none of the biological indicators demonstrated growth of the indicator organism. A 6-log reduction at the half cycle exposure time indicates that a full cycle (twice the half cycle exposure time) will produce sufficient lethality to effect at least a 12-log reduction and provide a 10^{-6} sterility assurance level (SAL).

Warranty

Integra Warranty for CUSA[®] Excel and CUSA[®] Excel+ Ultrasonic Surgical Aspirator Systems

1. Warranty.

INTEGRA LIFESCIENCES CORPORATION and its wholly owned subsidiaries ("Integra") warrant to Integra authorized distributors and the original purchaser only that each new Integra CUSA Excel and CUSA Excel+ Ultrasonic Surgical Aspirator (hereinafter the Equipment or the product) is free from manufacturing defects in material and workmanship under normal use and service for a period of one (1) year (except as otherwise expressly provided as to accessory items) from the date of invoice by Integra (or its authorized distributor) to the original purchaser, but in no event beyond the expiration date stated on any product labeling (hereinafter the Warranty Period). For purposes of products sold by Integra through an authorized distributor of Integra, "original purchaser" shall include the purchaser of Integra products to whom the distributor first sells the product. The original purchaser is hereinafter referred to as Customer.

1.1. *Coverage.* During the Warranty Period, Integra shall provide free-of-charge service and maintenance consistent with the provisions of Section 3 of this Warranty, so that the Equipment conforms to the specifications defined in the CUSA Excel and CUSA Excel+ Ultrasonic Surgical Aspirator Operator's Manuals, as such Operator's Manuals may be modified by Integra from time to time (the "Specifications").

1.2. *Exclusions.* The Warranty shall not apply in any manner to service or maintenance of the Equipment, or to replacement of its parts, with respect to:

- (i) use of Equipment with any tips, flues, and manifold tubing sets and accessories other than those manufactured by Integra LifeSciences;
- (ii) defects arising out of materials or parts provided, modified or designed by anyone other than an authorized Integra service agent (the Integra "Service Agent");
- (iii) defects emanating from improper or negligent installation, storage or use of the Equipment or any component thereof, including but not limited to operating the Equipment not in accordance with instructions provided in the Operator's Manual;
- (iv) defects arising from improper or negligent cleaning or sterilization methods or improper maintenance of the Equipment;

-
- (v) defects resulting from repairs or service of the Equipment provided other than by Integra or its authorized representatives;
 - (vi) defects arising from accidental damage to the Equipment, acts of God, electrical power damage, equipment malfunction, unusual stress, unreasonable operating procedures or abnormal or extreme operating conditions; and
 - (vii) normal wear and tear.

2. Service, Repairs and Replacement.

2.1. *Service and Repairs.* All service and repairs covered by this Warranty may be referred to hereinafter as "in-warranty repairs," and all service and repairs not covered by this Warranty may be referred to as "out-of-warranty repairs." Integra's sole obligation for in-warranty repairs shall be to make all necessary adjustments and repairs in accordance with this Warranty. Integra shall charge Customer at Integra standard rates for any out-of-warranty repair performed by Integra.

2.2. *Equipment Replacement.* The defective Equipment or part thereof that is replaced in accordance with the Warranty shall be the property of Integra. Integra reserves the right to fill spare parts requests using refurbished sub-assemblies provided that such sub-assemblies are functionally equivalent to new sub-assemblies and carry the same warranty as the replaced sub-assemblies.

2.3. *Notification.* In order to avail itself of its rights under the Warranty, Customer or Integra authorized distributors, must immediately notify Integra of any defects and provide Integra every opportunity to inspect and remedy defects.

3. Repair Parts and Services.

3.1. Included under the Warranty are the following services:

3.1.1. *Consoles.* Integra or its distributor, when authorized for this purpose, shall, if possible, perform on-site repair of consoles and where not possible or otherwise decided at the sole discretion of Integra, Integra or its distributor shall arrange and pay to ship the affected Equipment to the designated repair facility. Integra or its distributor authorized for this purpose shall repair the affected Equipment or replace a console by a new or refurbished console (all of which at the discretion of Integra), that shall carry the same remaining warranty as the original equipment.

3.1.2. *Handpieces.* Integra shall repair or replace any defective handpieces covered by the Warranty by a new or refurbished handpiece (all of which at the discretion of Integra) that shall carry the same remaining warranty as the original equipment (an "Exchange Handpiece").

3.2. *Modifications to Covered Equipment.* From time to time, at its sole discretion, Integra may propose modifications to the covered Equipment and to the Specifications for the Equipment. Subject to Customer's approval and at its sole expense, the Customer may request Integra to make such modifications to the covered Equipment and to the Specifications. Integra shall make such modifications for the Customer, which modifications may include the installation of new parts in the Equipment, at a price equal to the then-current list price for such modifications, as such list price is established by Integra in its sole discretion.

4. Quality Control.

4.1. Customer shall maintain reasonable standards of quality control, operations, procedures, safety testing and inspection of Equipment to ensure that unnecessary service or maintenance is not required hereunder.

4.2. Customer shall provide a technical counterpart to Integra's Service Agent for assistance in Integra's telephonic diagnosis of the malfunction with the Equipment. Customer shall reasonably accept Integra's determination whether a repair or service is an in-warranty repair or an out-of-warranty repair.

5. Limitation of Liability.

5.1. INTEGRA's sole responsibility under the warranties described in Section 1 shall be repair or replacement, at INTEGRA's sole discretion at INTEGRA's expense, subject to the terms of this warranty and applicable agreements. THE WARRANTIES DESCRIBED IN SECTION 1 HEREOF ARE EXCLUSIVE AND ARE GIVEN AND ACCEPTED IN LIEU OF ALL OTHER WARRANTIES OF INTEGRA OR ITS SERVICE AGENTS WITH RESPECT TO THE QUALITY, PERFORMANCE AND OPERATION OF THE EQUIPMENT, WRITTEN OR ORAL, EXPRESS OR IMPLIED, AND WHETHER OR NOT ATTRIBUTABLE TO SERVICE PERFORMED PURSUANT TO THE WARRANTY. ALL OTHER REPRESENTATIONS OR WARRANTIES OF INTEGRA OR ITS REPRESENTATIVES, EXPRESS OR IMPLIED, WITH RESPECT TO THE EQUIPMENT OR THE SERVICES, DIAGNOSIS, ADVICE, ASSISTANCE OR PARTS TO BE TENDERED PURSUANT TO THE WARRANTY, INCLUDING, WITHOUT LIMITATION, THOSE OF MERCHANTABILITY AND FITNESS FOR A PARTICULAR PURPOSE, ARE HEREBY EXPRESSLY DISCLAIMED. IN NO EVENT SHALL INTEGRA, ITS ASSIGNEES OR SERVICE AGENTS BE LIABLE FOR LOSS OF USE, REVENUE OR PROFIT OR ANY OTHER INDIRECT, INCIDENTAL, EXEMPLARY, CONSEQUENTIAL, SPECIAL OR OTHER DAMAGES, WHETHER ARISING IN CONTRACT OR IN TORT, BY VIRTUE OF THE WARRANTY OR ANY PERFORMANCE OR BREACH BY INTEGRA, ITS ASSIGNEES OR SERVICE AGENTS HEREUNDER OR PURSUANT HERETO.

5.2. Customer agrees that, notwithstanding the technical assistance provided pursuant to the Warranty by Integra or its representatives, Customer shall be fully and solely responsible for all treatments performed or attempted with the Equipment. INTEGRA MAKES NO REPRESENTATION OR WARRANTY AS TO THE EFFICACY OF THE EQUIPMENT OR OF THE TECHNICAL ASSISTANCE TO BE RENDERED BY INTEGRA, ITS ASSIGNEES OR SERVICE AGENTS, FOR PURPOSES OF THE PARTICULAR TREATMENT THAT CUSTOMER INTENDS TO PERFORM FOR THIRD PARTIES. Moreover, Integra disclaims any liability with respect to the efficacy of the Equipment or of said technical assistance or with respect to any claims by third parties related to any treatment performed by Customer.

5.3. THIS INTEGRA LIMITED WARRANTY IS EXCLUSIVE AND IN LIEU OF ALL OTHER WARRANTIES, EXPRESS OR IMPLIED, AND OF ALL OTHER OBLIGATIONS OR LIABILITIES ON INTEGRA'S PART OR THE PART OF ITS DISTRIBUTORS, AND INTEGRA NEITHER ASSUMES NOR AUTHORIZES ANY REPRESENTATIVE OR OTHER PERSON TO ASSUME FOR IT ANY OTHER LIABILITY IN CONNECTION WITH INTEGRA'S PRODUCTS.

INTEGRA DISCLAIMS ALL OTHER WARRANTIES, EXPRESS OR IMPLIED INCLUDING ANY IMPLIED WARRANTY OF MERCHANTABILITY OR OF FITNESS FOR A PARTICULAR PURPOSE OR APPLICATION OR WARRANTY OF QUALITY AS WELL AS ANY EXPRESS OR IMPLIED WARRANTY TO PATIENTS. No warranty or guarantee may be created by any act or statement nor may this Standard Warranty be modified in any way,

except as a result of a writing signed by an officer of INTEGRA. These limitations on the creation or modification of this warranty may not be waived or modified orally or by any conduct.

5.4 IN NO EVENT SHALL INTEGRA AUTHORIZED DISTRIBUTORS BE LIABLE TOWARDS CUSTOMER FOR ANY INCIDENTAL, INDIRECT, CONSEQUENTIAL OR PUNITIVE DAMAGES IN CONNECTION WITH THE ACQUISITION OR USE OF ANY INTEGRA PRODUCT. Further, this warranty shall not apply to, and INTEGRA authorized distributors shall not be responsible towards Customer for, any loss, arising in connection with the purchase or use of any INTEGRA product that has been repaired by anyone other than an authorized INTEGRA service representative or altered in any way so as to affect its stability or reliability, or which has been subject to misuse, negligence or accident, or which has been used otherwise than in accordance with the instructions furnished by INTEGRA. THIS INTEGRA DISTRIBUTOR LIMITED WARRANTY IS EXCLUSIVE AND IN LIEU OF ALL OTHER WARRANTIES TOWARDS CUSTOMER, EXPRESS OR IMPLIED, AND OF ALL OTHER OBLIGATIONS OR LIABILITIES TOWARDS CUSTOMER ON INTEGRA AUTHORIZED DISTRIBUTOR'S PART.

INTEGRA AUTHORIZED DISTRIBUTORS DISCLAIM ALL OTHER WARRANTIES TOWARDS CUSTOMER, EXPRESS OR IMPLIED INCLUDING ANY IMPLIED WARRANTY OF MERCHANTABILITY OR OF FITNESS FOR A PARTICULAR PURPOSE OR APPLICATION OR WARRANTY OF QUALITY AS WELL AS ANY EXPRESS OR IMPLIED WARRANTY TO PATIENTS OR OTHER THIRD PARTIES.

5.5 Force Majeure. Notwithstanding anything to the contrary herein contained, if the performance of the Warranty by Integra, Integra authorized distributors, or Customer or any obligation of Integra, Integra authorized distributors, or Customer hereunder is prevented, restricted or interfered with by reason of fire, explosion, act of God, labor disputes or accidents affecting performance under the Warranty, or war, mobilization, civil commotions, blockade or embargo, or any future law, regulation, ordinance or requirement of any government or regulatory agency or any other act, whatsoever similar to those above enumerated, or any other circumstance being beyond the reasonable control of Integra, Integra authorized distributors, or Customer, then and in that event Integra, Integra authorized distributors, or Customer, as the case may be, shall promptly notify the other party hereto of the difficulties resulting therefrom, and any of the foregoing events shall excuse any performance required under the Warranty.