



SEL-411L Advanced Line Differential Protection, Automation, and Control System

Line Current Differential Protection Automation and Control System



Key Features and Benefits

The SEL-411L Advanced Line Differential Protection, Automation, and Control System combines high-speed line current differential, distance, and directional protection with complete bay control. This data sheet applies to all the model options of the SEL-411L-0, -1, -A, and -B relays. *Table 5* details which features, functions, and applications are supported by each of the SEL-411L models.

- **Line Current Differential Protection.** The 87L function of the SEL-411L provides protection for any transmission line or cable with as many as three terminals over serial communications and as many as four terminals over Ethernet communications, in three-pole or single-pole tripping modes. Each terminal can be connected in a dual breaker arrangement.
- **Generalized Alpha Plane.** Phase-segregated (87LP), negative-sequence (87LQ), and zero-sequence (87LG) differential elements use patented generalized alpha plane comparators. Combined with overcurrent supervision, external fault detection, optional charging current compensation, and disturbance detection logic, these provide the 87L function with exceptional security and sensitivity. An adaptive feature increases security of the 87L function if:
 - An external fault is detected
 - Communications synchronization is degraded
 - Charging current compensation is enabled but momentarily impossible because of loss-of-potential (LOP) or other conditions

The generalized alpha plane principle is similar to the two-terminal SEL-311L. However, the SEL-311L and SEL-411L are two completely independent hardware and firmware platforms. They are not compatible to be applied in a line-current differential scheme.

- **Inclusion of Power Transformers in the Protective Zone.** The SEL-411L allows for in-line power transformer applications by compensating for transformer vector group, ratio, and zero-sequence current. The 87L function supports both harmonic blocking and/or harmonic restraint for stabilization during transformer inrush conditions. During over-excitation conditions, the SEL-411L uses fifth-harmonic current to secure the 87L elements. The 87L function can protect multiwinding transformers.

- ▶ **Charging Current Compensation.** Line charging current compensation enhances sensitivity of the 87L elements in applications for protection of long, extra high voltage lines or cables. Charging current is calculated by using the measured line terminal voltages and is then subtracted from the measured phase current. This compensation method results in accurate compensation for both faulted and non-faulted system conditions. The line charging current algorithm has built-in fallback logic in the event of an LOP condition.
- ▶ **External Fault Detector.** An external fault detection algorithm secures the 87L elements against CT errors when the algorithm detects one of the two following conditions:
 - An increase in the through current of the protected zone that is not accompanied by an increase in the differential current of the protected zone (typical of an external fault)
 - The dc component of any current exceeds a preset threshold compared with the ac component without the differential current having a significant change (typical when energizing a line reactor or a power transformer)
- ▶ **Stub Bus Protection.** Disconnect status inputs and voltage elements can enable high-speed stub bus protection and proper response toward remote SEL-411L relays. Stub bus protection in the SEL-411L provides a true restrained differential function that yields exceptional security in dual-breaker applications.
- ▶ **87L Communications Protocols Supported.** The SEL-411L allows serial 87L communication over direct point-to-point fiber, IEEE C37.94 multiplexed fiber, EIA-422, and G.703 media.
- ▶ **Data Synchronization.** The relay allows for synchronizing data exchanged between relays based on the channel (for symmetrical channels) or using external time sources for applications over Ethernet or asymmetrical channels. Selecting the synchronization method is on a per-channel basis. If you use external time sources, the SEL-411L provides built-in fallback logic to deal with any loss or degradation of such sources.
- ▶ **Broken Conductor Detection (BCD).** The optional BCD function can detect a broken conductor over the length of the protected line to help mitigate possible fire or public hazard. The BCD element is designed for multiterminal overhead or hybrid lines, including tapped line configurations to detect a conductor break before it converts into a shunt fault.
- ▶ **Complete Distance Protection.** You can apply as many as five zones of phase and ground distance and directional overcurrent elements. Select mho or quadrilateral characteristics for any phase or ground distance element. Use the optional high-speed distance elements and series-compensation logic to optimize protection for critical lines. Patented coupling capacitor voltage transformer (CCVT) transient overreach logic enhances the security of Zone 1 distance elements. Best Choice Ground Directional Element[®] logic optimizes directional element performance and eliminates the need for many directional settings. Apply the distance and directional elements in communications-based protection schemes, such as POTT, DCB, and DCUB, or for instantaneous or time-step backup protection.
- ▶ **Power Swing Blocking and Out-of-Step Tripping.** You can select power swing blocking of distance elements for stable power swings or out-of-step tripping for unstable power swings. A zero-setting, out-of-step detection logic is available, eliminating the need for settings and extensive power system studies.
- ▶ **Synchronism Check.** Synchronism check can prevent circuit breakers from closing if the corresponding phases across the open circuit breaker are excessively out of phase, magnitude, or frequency. The synchronism-check function has a user-selectable synchronizing voltage source and incorporates slip frequency, two levels of maximum angle difference, and breaker close time into the closing decision.
- ▶ **Reclosing Control.** You can incorporate programmable single-pole or three-pole trip and reclose of one or two breakers into an integrated substation control system. Synchronism and voltage checks from multiple sources provide complete bay control.
- ▶ **High-Accuracy Traveling-Wave Fault Locator.** On two terminal lines with a high-accuracy time source, the SEL-411L achieves the highest possible fault location accuracy with a double-ended traveling-wave (TW) algorithm. A dedicated analog-to-digital converter samples currents at 1.5625 MHz and extracts high-frequency content to calculate fault location.
- ▶ **Advanced Multiterminal Fault Locator.** Utilities can efficiently dispatch line crews to quickly isolate line problems and restore service faster. For two-terminal lines, data are used from each terminal to achieve highly accurate fault location with a traveling-wave algorithm and with an impedance-based fault location estimate. For three-terminal lines, the relay accurately locates faults by using data from each terminal to compute a three-terminal impedance-based fault location estimate and correctly identifies a faulted line segment. Upon loss of communication or degraded data synchronization, the relay returns to a single-ended method, always providing valuable fault location results to aid inspection and repair. The SEL-411L displays the traveling-wave and best available impedance-based fault location estimates for each fault.

- ▶ **Dual CT Input.** For breaker-and-a-half, ring-bus, or double-bus double-breaker bus applications, the SEL-411L provides proper security for the 87L function by supporting two current inputs for individual measurements of each breaker. Through the use of SELOGIC[®] control equations, you can dynamically include or exclude each current input from the differential zone. With this capability, you can use the SEL-411L in such advanced applications as breaker substitution in double-bus single-breaker or transfer bus configurations.
- ▶ **Primary Potential Redundancy.** Multiple voltage inputs to the relay provide primary voltage input redundancy. Upon loss-of-protection (LOP) detection, the relay can use inputs from an electrically equivalent source connected to the relay.
- ▶ **Comprehensive Metering.** The built-in, high-accuracy metering functions can improve feeder loading. Use watt and VAR measurements to optimize feeder operation. Use differential metering to access remote terminal current values. Minimize equipment needs with full metering capabilities, including rms, maximum/minimum, demand/peak, energy, and instantaneous values.
- ▶ **Bay Control.** The relay provides bay control functionality with status indication and control for disconnect switches. The relay features control for as many as two breakers and status indication of as many as three breakers. Numerous predefined user-selectable mimic displays are available; the selected mimic appears on the front-panel screen in one-line diagram format. The one-line diagram includes user-configurable labels for disconnect switches, breakers, bay name, and display for as many as six analog quantities. The relay features SELOGIC programmable local control supervision of breaker and disconnect switch operations.
- ▶ **Breaker Failure.** High-speed (less than one cycle) open-pole detection logic reduces coordination times for critical breaker failure applications. Apply the relay to supply breaker failure protection for all supported breakers. Logic for breaker failure retrip and initiation of transfer tripping is included.
- ▶ **IEC 60255-149 Compliant Thermal Model.** The relay can provide a configurable thermal model for the protection of a wide variety of devices. This function can activate a control action or issue an alarm or trip when equipment overheats as a result of adverse operation conditions. A separate resistance temperature detector (RTD) module is required for this application.
- ▶ **Ethernet Access.** The optional Ethernet card grants access to all relay functions. Use IEC 61850 Manufacturing Message Specification (MMS) or DNP3 protocol directly to interconnect with automation systems. You can also connect to DNP3 networks through a communications processor. Use File Transfer Protocol (FTP) for high-speed data collection. Connect to substation or corporate LANs to transmit synchrophasors by using TCP or UDP internet protocols.
- ▶ **Serial Data Communication.** The relay can communicate serial data through SEL ASCII, SEL Fast Message, SEL Fast Operate, MIRRORED BITS[®], and DNP3 protocols. Synchrophasor data are provided in either SEL Fast Message or IEEE C37.118 format.
- ▶ **Automation.** The enhanced automation features include programmable elements for local control, remote control, protection latching, and automation latching. Local metering on the large front-panel LCD eliminates the need for separate panel meters. Serial and Ethernet links efficiently transmit key information, including metering data, protection element and control I/O status, synchrophasor data, IEC 61850 Edition 2 GOOSE messages, Sequential Events Recorder (SER) reports, breaker monitoring, relay summary event reports, and time synchronization. Apply expanded SELOGIC[®] control equations with math and comparison functions in control applications. Incorporate as many as 1000 lines of automation logic to accelerate and improve control actions.
- ▶ **Synchrophasors.** You can make informed load dispatch decisions based on actual real-time phasor measurements from relays across your power system. Record streaming synchrophasor data from the relay for system-wide disturbance recording. Control the power system by using local and remote synchrophasor data.
- ▶ **Breaker and Battery Monitoring.** You can schedule breaker maintenance when accumulated breaker duty (independently monitored for each pole) indicates possible excess contact wear. The relay records electrical and mechanical operating times for both the last operation and the average of operations since function reset. Alarm contacts provide notification of substation battery voltage problems (as many as two independent battery monitors in some SEL-400 series relays) even if voltage is low only during trip or close operations.
- ▶ **Six Independent Settings Groups.** The relay includes group logic to adjust settings for different operating conditions, such as station maintenance, seasonal operations, emergency contingencies, loading, source changes, and adjacent relay settings changes. Select the active group settings by control input, command, or other programmable conditions.
- ▶ **Software-Invertible Polarities.** Inverting individual or grouped CT and PT polarities allows you to account for field wiring or zones of protection changes. CEV files and all metering and protection logic use the inverted polarities, whereas COMTRADE event reports do not use inverted polarities but rather record signals as applied to the relay.
- ▶ **Parallel Redundancy Protocol (PRP).** PRP provides seamless recovery from any single Ethernet network failure. The Ethernet network and all traffic are fully duplicated with both copies operating in parallel.

- **IEC 61850 Operating Modes.** The relay supports IEC 61850 standard operating modes such as Test, Blocked, On, and Off.
- **IEEE 1588, Precision Time Protocol (PTP).** PTP provides high-accuracy timing over an Ethernet network.
- **Digital Relay-to-Relay Communications.** MIRRORRED BITS communications can monitor internal element conditions between bays within a station, or between stations, using SEL fiber-optic transceivers. Send digital, analog, and virtual terminal data over the same MIRRORRED BITS channel.
- **Sequential Events Recorder (SER).** The SER records the last 1000 events, including setting changes, startups, and selectable logic elements.
- **Oscillography and Event Reporting.** The relay records voltages, currents, and internal logic points at a sampling rate as fast as 8 kHz. Offline phasor and harmonic-analysis features allow investigation of bay and system performance. Time-tag binary COMTRADE event reports with high-accuracy time stamping for accuracy better than 10 μs.
- **Digitally Signed Upgrades.** The relay supports upgrading the relay firmware with a digitally signed upgrade file. The digitally signed portion of the upgrade file helps ensure firmware and device authenticity after it is sent over a serial or Ethernet connection.
- **Increased Security.** The relay divides control and settings into seven relay access levels; the relay has separate breaker, protection, automation, and output access levels, among others. Set unique passwords for each access level.
- **Rules-Based Settings Editor.** You can communicate with and set the relay by using an ASCII terminal or use QuickSet to configure the relay and analyze fault records with relay element response. Use as many as 200 aliases to rename any digital or analog quantity in the relay.

Functional Overview

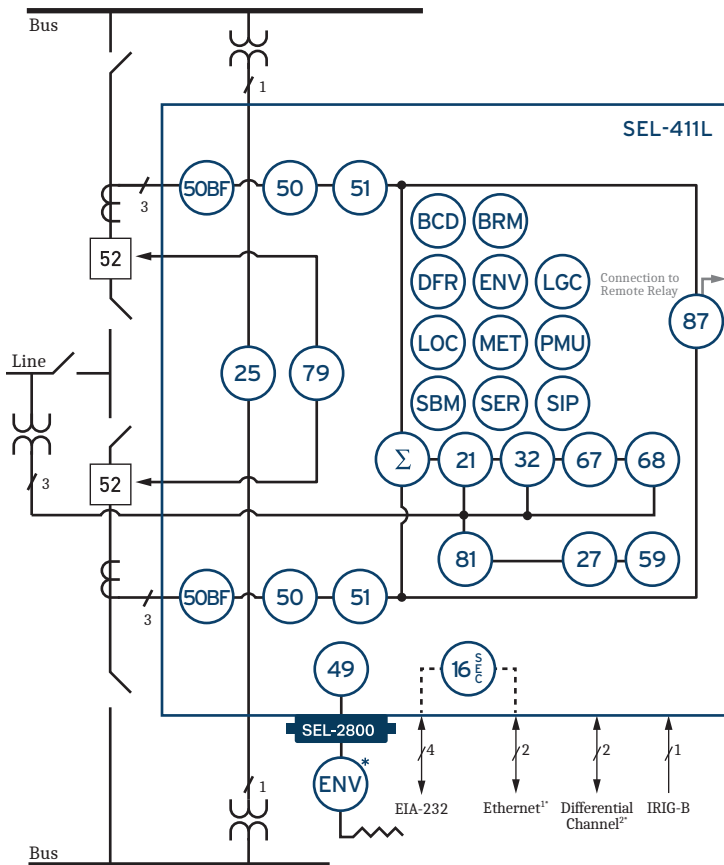

ANSI NUMBERS/ACRONYMS AND FUNCTIONS	
21	Phase and Ground Distance
25	Synchronism Check
27	Undervoltage
32	Directional Power
49	IEC 60255-Compliant Thermal Model
50	Overcurrent (Phase, Zero-Sequence, and Negative-Sequence)
50BF	Dual Breaker Failure Overcurrent
51	Time-Overcurrent (Phase, Zero-Sequence, and Negative-Sequence)
59	Overvoltage
67	Directional Overcurrent
68	Out-of-Step Block/Trip
79	Single-and Three-Pole Reclosing
81	Over- and Underfrequency
87	Current Differential

ADDITIONAL FUNCTIONS	
16 SEC	Access Security (Serial, Ethernet)
85 RIO	SEL MIRRORRED BITS Communications
BCD	Broken Conductor Detection
BRM	Breaker Wear Monitor
DFR	Event Reports
ENV	SEL-2600 RTD Module*
LGC	SELogic Control Equations
LOC	Fault Locator
MET	High-Accuracy Metering
PMU	Synchphasors
RTU	Remote Terminal Unit
SBM	Station Battery Monitor
SER	Sequential Events Recorder
SIP	Software-Invertible Polarities

1 Copper or Fiber Optic
 2 Serial or Ethernet (Ethernet coming soon)
 * Optional Feature

Figure 1 Functional Overview

Protection Features

The SEL-411L contains all the necessary protective elements and control logic to protect overhead transmission lines and underground cables (see *Figure 2*).

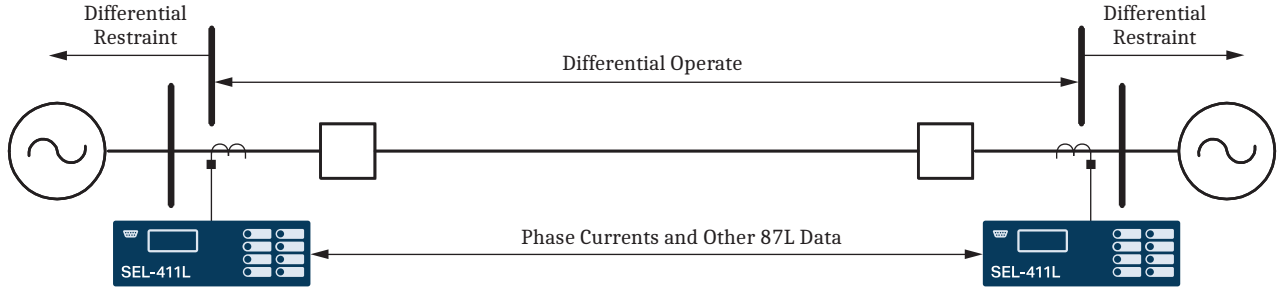

Figure 2 Differential Element Operate and Restraint Regions

Complete Current Differential Protection

The SEL-411L differential elements compare phase, negative-sequence, and zero-sequence components from each line terminal, as *Figure 2* illustrates.

The differential protection in the SEL-411L compares the vector ratio of the equivalent local and remote currents in a complex plane, known as the alpha plane, as *Figure 3* shows. For load and external faults with no CT or communication errors, the vector ratio of remote current to local current is -1 or $1\angle 180^\circ$. The SEL-411L restraint region surrounds the ideal external fault and load current point, allowing for errors in both magnitude and phase angle. CT saturation, channel asymmetry, and other effects during faults outside the protected zone produce shifts in the magnitude and angle of the ratio. The characteristic provides proper restraint for these conditions while still providing good sensitivity for high resistance faults with its negative- and zero-sequence differential elements. You can adjust both the angular extent and the radial reach of the restraint region.

The differential protection algorithms offer great security against CT saturation effects. In addition to providing individual breaker currents to the differential element, the relay incorporates ultra-fast external fault detection to cope with fast and severe CT saturation resulting from high fault currents. It also provides a standing dc detection algorithm to cope with slower saturation resulting from large and slowly decaying dc offset in the transformer inrush or fault currents under large X/R ratios.

Such provisions prevent the SEL-411L from tripping on through faults and allows relaxation of CT requirements for current differential applications.

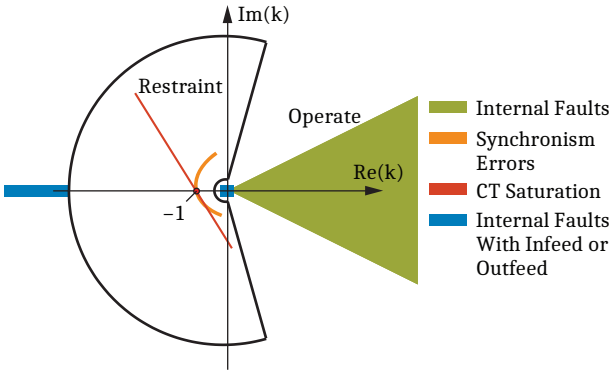

Figure 3 Operate and Restraint Regions in Alpha Plane Responses to System Conditions

The SEL-411L allows single-pole tripping from the 87L elements. This includes tripping highly resistive faults from the sensitive 87LQ and 87LG elements. These 87LQ and 87LG elements do not have inherent faulted-phase identification capabilities. Therefore, the 87L function incorporates its own faulted-phase selection logic and uses symmetrical components in the phase differential currents to provide very sensitive, accurate, and fast fault-type identification. *Figure 4* shows the operate times for the 87L elements.

When performing single-pole tripping without differential enabled or available, the SEL-411L uses a proven single-ended fault identification logic based on the angular relationships in the local current.

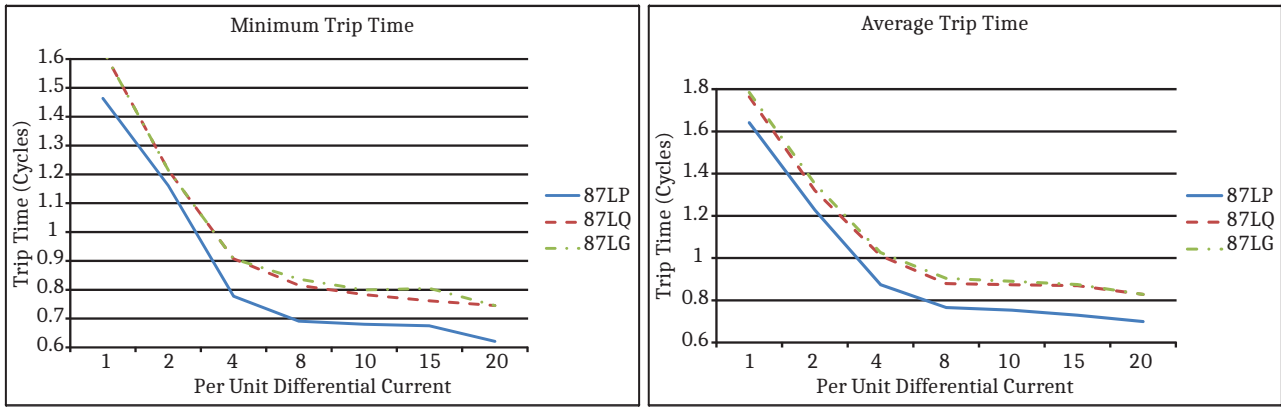

Figure 4 Operating Time Curves

Two-Breaker Bays and Multiterminal Lines

The SEL-411L can accommodate lines terminated as dual-breaker connections or multiterminal lines. The SEL-411L supports as many as three terminal applications over serial and as many as four terminals over Ethernet communications. The relays measure and use all of the current inputs and calculate an equivalent two-terminal alpha plane current. The relays use a patented method to develop a remote and local current for an equivalent two terminal system. The equivalent local and remote currents are applied to the tried and true alpha plane comparator. As a result, the SEL-411L extends the advantages of alpha plane implementation to dual-breaker multiterminal lines.

Line Charging Current Compensation

The SEL-411L compensates for line charging current by estimating an instantaneous value of the total line charging current on a per-phase basis and then subtracting this value from the measured differential current. The relay uses instantaneous values of the line voltage and the susceptance of the line (cable) to calculate charging current in real time on a sample-by-sample basis.

This method is accurate under steady state and transient conditions. These latter conditions can include external faults, internal faults, switching events, and line energization, even with uneven breaker pole operation. Compensating the phase currents removes the charging current from the sequence currents automatically and improves the sensitivity of the sequence 87L elements.

Each SEL-411L terminal with access to voltage uses the lump parameter model of the transmission line and the local terminal voltage to calculate the total charging current:

$$i_{CHARGE} = C_{LINE} \cdot \frac{dv}{dt}$$

The relay subtracts a portion of the total charging current proportional to the number of compensating terminals from the local phase current. For example, with two relays compensating for the charging current, each subtracts half of the total charging current.

By subtracting the total charging current from the differential signal prior to using the generalized alpha plane algorithm, the relay moves the operating point to the ideal blocking point ($1 \angle 180^\circ$) when no internal fault conditions exist. This allows more sensitive settings, particularly for the 87LP element.

A loss of voltage at one of the line terminals causes the scheme to use remaining voltages, with properly adjusted multipliers, for compensation, resulting in removal of the total line charging current. If no compensation is possible, the fallback logic engages more secure settings to retain security of protection.

External Fault Detection

An external fault detection algorithm analyzes particular characteristics of the 87L zone currents to identify external events as a fault, load pickup under exceptionally high X/R ratio, or a transformer inrush condition that could jeopardize 87L security with possible subsequent CT saturation. Assertion of the algorithm occurs before and regardless of CT saturation, bringing proper security to the 87L scheme, particularly to the 87LQ and 87LG elements.

The external fault detection algorithm consists of two paths:

- The ac saturation path guards against potentially fast and severe CT saturation resulting from high current magnitudes such as those occurring during close-in external faults.
- The dc saturation path guards against typically slower and less severe saturation that can result from relatively large and long-lasting dc component in current signals as can exist during transformer inrush or slowly cleared external faults under large X/R ratios.

The principle of operation for ac saturation is based on the observation that all CTs of the differential zone perform adequately for a short time into the fault. If so, the differential current does not develop during the external faults, but the restraint current increases. This external fault pattern differs from the internal fault pattern in that both the differential and restraint currents develop simultaneously. The algorithm monitors the difference by responding to changes in the instantaneous differential current and the instantaneous restraint currents that the relay measures during one power cycle. The algorithm declares an external fault if it detects sufficient increase in the restraint current, no accompanying increase occurs in the differential current, and the situation persists for a predetermined portion of a power cycle. When both currents develop simultaneously, the EFD_{AC} logic does not assert.

The principle of operation for dc saturation checks if the dc component in any of the local 87L zone currents is relatively high as compared with the CT nominal and the ac component at that time. If the dc component is high and the differential current is low compared with the restraint current, EDF_{DC} asserts in anticipation of possible CT saturation, resulting from overfluxing by the dc component.

The SEL-411L combines the output from both logics to drive an external fault-detected (EFD) Relay Word bit. The relay uses the OR combination of the ac path and the dc path, not only to drive the local external fault detector, but also to transmit information about the external fault to all remote terminals.

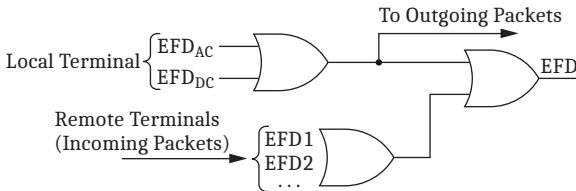

Figure 5 Combined External Fault Detector

The EFD Relay Word in *Figure 5* is an OR combination of the local and remote external fault detectors. This allows all terminals to receive an alert about an external fault even if one of the terminals has minimal current contribution to the fault. Upon assertion of the EFD Relay Word bit, all 87L elements switch to high security mode. No user settings are necessary for the EFD logic.

In-Line Transformers

The 87L function performs in-line power transformer vector group, ratio, and zero-sequence compensation. The function also provides logic for blocking during overexcitation conditions and offers both harmonic restraint and blocking to accommodate transformer inrush. Proper compensation of the measured current occurs at the local relay prior to remote terminal transmission of current data. Once

the local relay receives data from the remote terminals, it can consume these data by using the same signal processing and algorithms as in the plain line application (see *Figure 6*).

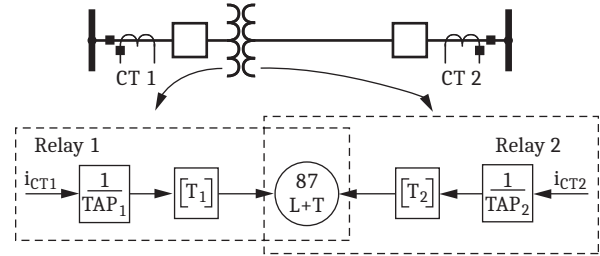

Figure 6 Compensation for In-Line Transformers at the Local Relay Allows the Algorithms to Remain Unchanged

Time-Overcurrent Differential Protection

The SEL-411L allows protection of lines with tapped loads without the current measurement at the tap. You can make such partial line current differential applications selective, and these may be acceptable if you connect tapped and unmeasured load through a step-down power transformer. The transformer impedance reduces the level of line differential currents for network faults fed from the low side of the transformer, providing better coordination margins.

This application allows you to protect lines having multiple load taps without the need to invest in high-grade communications and install the SEL-411L relays at every tap of the line.

Overall, in the partial line current differential applications of the SEL-411L, we suggest following this approach:

- The 87L elements are applied as instantaneous but are intentionally desensitized to prevent operation for faults in the tapped load.
- The differential time overcurrent elements provide sensitive, but time-coordinated protection for the low-current line faults, some internal faults in the tapped transformer, and remote back-up for short-circuit protection in the tapped load network.

Use the selectable time-overcurrent elements to configure the differential time-overcurrent protection while coordinating with the phase-, negative-, or zero-sequence short-circuit protection of the tapped load network.

Security With Respect to Communication Events

Noise in a communications channel can corrupt data. The SEL-411L uses a 32-bit BCH code to protect data integrity. Any data integrity protection has a non-zero probability of defeat. To reduce the probability that a standing

noise condition could result in corrupted data and an unwanted 87L operation, the SEL-411L has sensitive and fast-acting disturbance detectors as *Figure 7* illustrates.

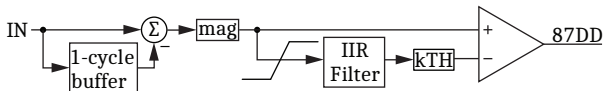

Figure 7 Adaptive Disturbance Detector Algorithm

Corrupted data that would activate the 87L elements or assert the 87 direct transfer trip (87DTT) would be short lived and constitute typically just a single packet. The SEL-411L supervises the 87L elements and 87DTT with the disturbance detector. As *Figure 8* illustrates, the 87L element or 87DTT element is delayed slightly without losing dependability even if the disturbance detectors were to fail to assert.

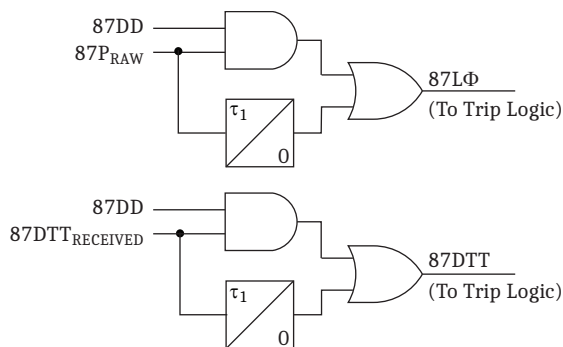

Figure 8 SEL-411L Disturbance Detection Application

The disturbance detectors are sensitive, but they will not assert under load conditions for periodic current or voltages, even for heavily distorted load current or voltages. No user settings are necessary for the disturbance detection logic.

87 Channel Monitoring

To aid commissioning and to help maintain security and dependability, the SEL-411L provides a set of channel monitoring and alarming functions. Considering that the 87L function is communications-dependent, it is beneficial to monitor the status of the communications channels. The 87L function itself responds to some monitored channel characteristics in real time to maintain proper security and dependability.

The monitoring functions of the SEL-411L include a round-trip channel delay, step change in the round-trip delay signifying path switching, noise burst and momentary channel break detection, channel asymmetry, 40 second and 24h lost packet counts, data integrity alarm, and wrong relay address alarm signifying cross-connection of communications paths. These monitoring functions provide overall assessment of channel quality for the user and feed into the internal 87L logic for security.

87L Communications Report

The SEL-411L provides an 87L communications report to visualize and summarize basic 87L configuration, as well as real-time and historical channel monitoring and alarming values. The report covers three major areas:

- 87L configuration and overall status such as relay identification, number of terminals in the 87L scheme, master or slave mode, channel problems, stub bus condition, in test, etc.
- Detailed channel configuration, diagnostics, and health information on a per-channel basis. Such information includes remote relay address, data synchronization method and status, list of any specific channel alarms asserted, round-trip channel delay, and channel asymmetry.
- Long-term channel characteristics on a per-channel basis as channel delay histogram, and worst-case channel delay with time stamp.

87L Channel Redundancy

The SEL-411L provides optional channel redundancy in two-terminal serial applications. You can order the SEL-411L with two 87L serial communications ports, which you can then use to connect two relays in a redundant fashion, incorporating different, typically independent communications equipment and paths. Often a direct point-to-point fiber connection is the primary channel, and a multiplexed channel over a SONET network serves as backup. The SEL-411L simultaneously sends data on both channels, and incorporates channel monitoring functions and logic to automatically switch between the primary and backup channels on the receiving end to maximize dependability and security. Excessive round-trip channel delay, elevated lost packet counts, detected channel asymmetry, and user-programmable conditions can all serve as triggers to initiate channel switchover.

Complete Distance Protection

The SEL-411L simultaneously measures as many as five zones of phase and ground mho distance protection plus five zones of phase and ground quadrilateral distance protection. You can apply these distance elements, together with optional high-speed distance elements, in communications-assisted and step-distance protection schemes. You can use expanded SELOGIC control equations to tailor the relay further to your particular application.

The relay includes LOP detection, load encroachment, and CCVT transient detection logic for enhanced security.

Optional series-compensated line logic can also be added to prevent overreach of the Zone 1 distance element, resulting from the series capacitor transient response.

Each of the distance elements has a specific reach setting. The ground distance elements include three zero-sequence compensation factor settings (k01, k0R, and k0F) to calculate ground fault impedance accurately. Setting k01 uses positive-sequence quantities to adjust zero-sequence transmission line impedance for accurate measurement.

Settings k0F and k0R account for forward and reverse zero-sequence mutual coupling between parallel transmission lines.

Figure 9 shows the performance times of the high-speed and standard distance elements for a range of faults, locations, and source impedance ratios (SIR).

Subcycle Tripping Times Using Optional High-Speed Distance Elements

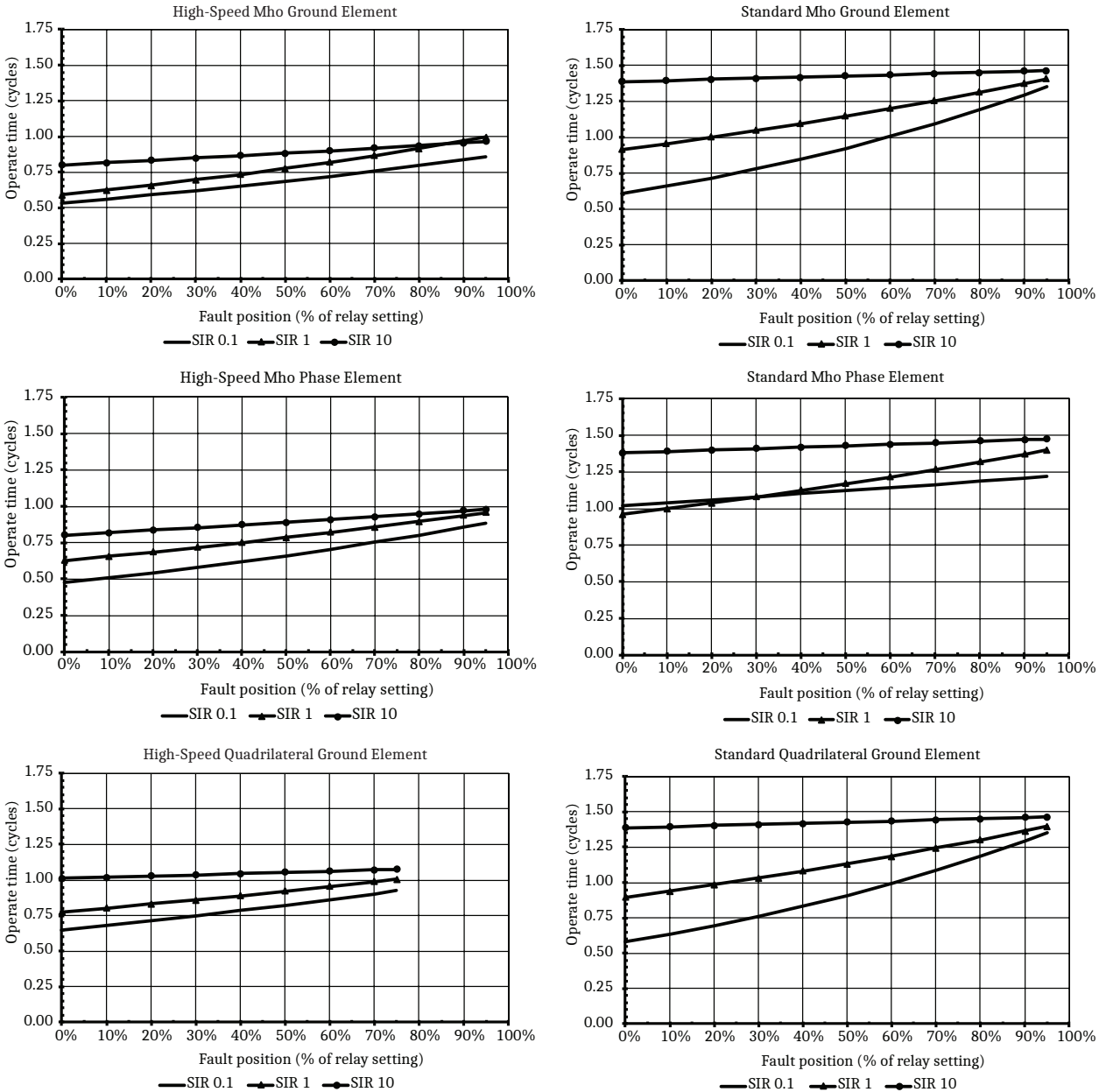

Figure 9 Distance Zone 1 Median Operating Time for Varying Fault Locations and Different SIRs

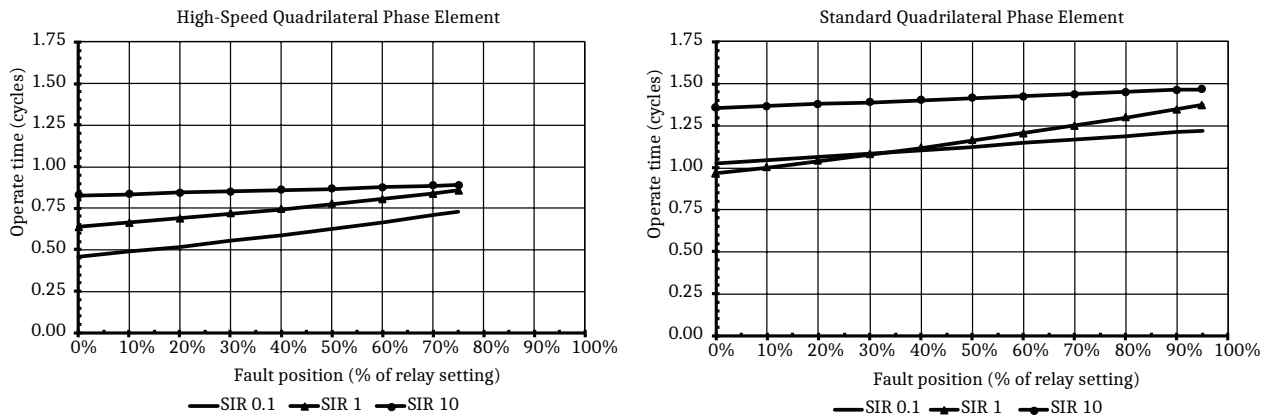

Figure 9 Distance Zone 1 Median Operating Time for Varying Fault Locations and Different SIRs (Continued)

Mho Distance Elements

The SEL-411L uses mho characteristics for phase and ground distance protection. Two zones are fixed in the forward direction, and the remaining three zones can be set for either forward or reverse. All mho elements use positive-sequence memory polarization that expands the operating characteristic in proportion to the source impedance (*Figure 10*). This provides dependable, secure operation for close-in faults.

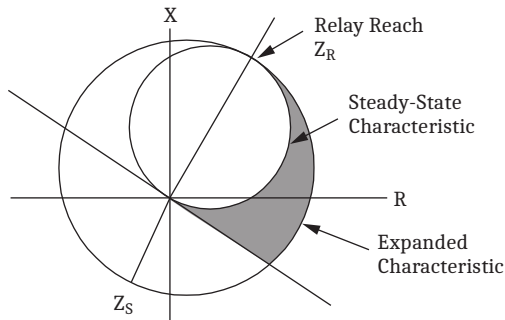

Figure 10 Mho Characteristic

As an optional addition to the standard distance elements, there are three zones (either three forward, or two forward and one reverse) of high-speed distance elements. These high-speed elements use voltage and current phasors derived from a fast half-cycle filter to provide subcycle tripping times. Settings are automatically associated with the standard element zone reach, requiring no additional settings.

Quadrilateral Distance Elements

The SEL-411L provides five zones of quadrilateral phase and ground distance characteristics for improved fault and arc resistance coverage including applications to short lines. The top line of the quadrilateral characteristic automatically tilts with load flow to avoid under- and over-

reaching. Available settings prevent overreaching of the quadrilateral characteristic from nonhomogeneous fault current components. You can choose to disable the mho and quadrilateral distance elements or use them either separately or concurrently.

Directional Elements

The SEL-411L includes a number of directional elements for supervision of overcurrent elements and distance elements. The negative-sequence directional element uses the same patented principle proven in the SEL-321 and SEL-421 relays.

The following three directional elements working together provide directional control for the ground overcurrent elements:

- Negative-sequence voltage-polarized directional element
- Zero-sequence voltage-polarized directional element
- Zero-sequence current-polarized directional element

Our patented Best Choice Ground Directional Element selects the best ground directional element for system conditions and simplifies directional element settings. (You can override this automatic setting feature for special applications.)

Communications-Assisted Tripping Schemes

Use MIRRORRED BITS communications with SEL fiber-optic transceivers for 3–6 ms relay-to-relay transmission time for pilot-tripping schemes. The relay supports communications ports or conventional inputs for the communications-assisted schemes that are independent and isolated from the 87L communications. This allows for true redun-

dancy between the 87L channels and communications-assisted scheme channels. Among the schemes supported are the following:

- Permissive overreaching transfer tripping (POTT) for two- or three-terminal lines
- Directional comparison unblocking (DCUB) for two- or three-terminal lines
- Directional comparison blocking (DCB)

Use the SELLOGIC control equation TRCOMM to program specific elements, combinations of elements, inputs, etc., to perform communications scheme tripping and other scheme functions. The logic readily accommodates the following conditions:

- Current reversals
- Breaker open
- Weak-infeed conditions
- Switch-onto-fault conditions

Step-distance and time-overcurrent protection provide reliable backup operation should the communications channel be lost.

Out-of-Step Detection

The relay provides two different algorithms for out-of-step detection. One of the two schemes may be selected by the user.

The zero-setting method requires no power system studies or any settings (other than enabling). Using local voltage measurements (see *Figure 11*) to closely approximate the swing center voltage (SCV) allows the relay to use the rate-of-change of SCV to quantify the power swing condition.

The second algorithm is a conventional out-of-step detection that provides timers and blinders that are set outside any of the distance element reach settings. A power swing is declared when an impedance locus travels through the blinders slower than a preset time.

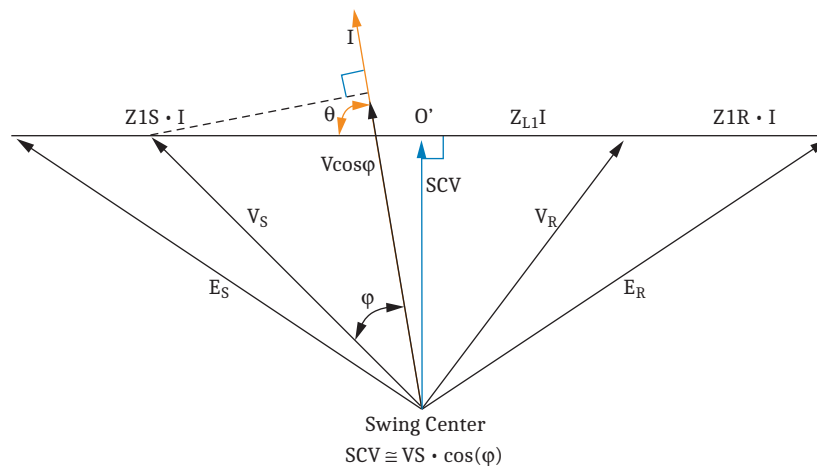

Figure 11 Applying V_S to Approximate the Swing Center Voltage Provides an Accurate Local Quantity to Detect Power Swings

Broken Conductor Detection

The BCD element is designed to detect a conductor break before it converts into a shunt fault. The BCD element can help in mitigating possible fire or public hazard. The detection logic compares the measured current against the line charging current threshold and uses the angular difference between the phase voltage and phase current to detect the conductor break. Additionally, the BCD function includes fault locating and phase identification to assist the user in restoring service. The BCD element can be applied to multiterminal overhead lines, hybrid lines and tapped lines.

Combined Current for Protection Flexibility

For traditional relays, when protecting a line fed from two breakers, such as a breaker-and-a-half system or double-

breaker system, you must parallel the CTs before connecting these inputs to the relay. The relay accepts two separate CT inputs (these CTs can be a different ratio) and combines the currents mathematically. This allows collecting separate current metering and breaker monitor information for each breaker. Breaker failure functions are also available on a per-breaker basis. Breaker diagnostic reports from the SEL-411L provide you comparative breaker information that you can use for advanced, proactive troubleshooting.

Multifunction Recloser With Flexible Applications

The SEL-411L includes both single-pole and three-pole trip and reclose functions for either one or two breakers control (*Figure 12*). Synchronism check is included for breaker control. Synchronizing and polarizing voltage inputs are fully programmable with dead line/dead bus closing logic,

as well as zero-closing-angle logic to minimize system stress upon reclosing. Program as many as two single-pole reclose attempts, four three-pole reclose attempts, and combined single-/three-pole reclosing sequences. Select leader and follower breakers directly, or use a SELOGIC control equation to determine reclosing order based on system conditions. Coupled with independent-pole-operating circuit breakers, this reclosing system gives maximum flexibility for present system conditions and for future requirements.

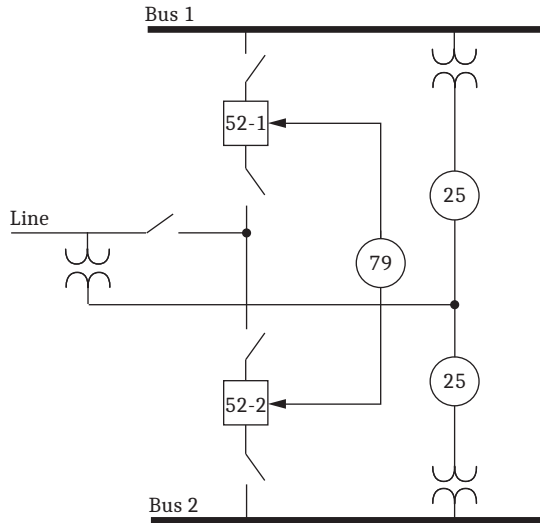

Figure 12 Two-Breaker Reclosing With Synchronism Check

Application Examples

The SEL-411L allows applications of the 87L function in one of several configurations, for which you can provide control through use of the E87CH (Enable 87 Channel) or 87PCH (87 Primary Channel) settings.

Two-Terminal Application With a Dual Serial Channel (E87CH = 2SD)

Set E87CH = 2SD when two communications channels are available. *Figure 13* shows an application consisting of two SEL-411L relays, each having two serial 87L ports that are connected by using two serial channels. This application provides for channel redundancy by using channel switch-over logic. The 87PCH setting controls which channel is the primary channel (i.e., the channel the SEL-411L uses for the 87L function if both channels are available and of equal quality). The primary channel can be direct point-to-point fiber, and the secondary channel can be a multiplexed channel.

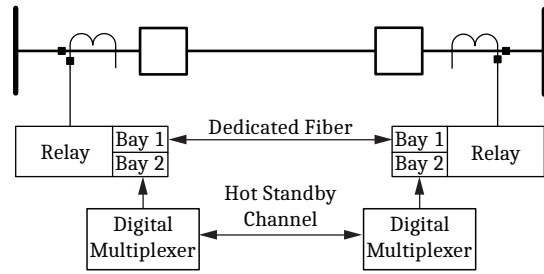

Figure 13 Two-Terminal Application With Hot Standby Channel

Three-Terminal Master Application With Serial Channels (E87CH = 3SM)

Figure 14 shows an SEL-411L set to 3SM, in which the relay uses two serial channels to communicate with two remote peers in a three-terminal application. If two channels are installed, connecting each relay with both of its remote peers, set E87CH in all relays to 3SM.

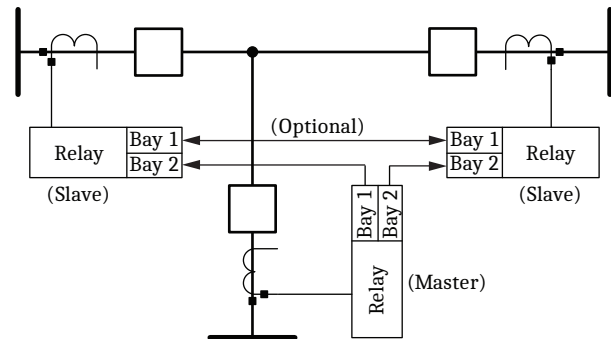

Figure 14 Three-Terminal 3SM Configuration With All Relays as Masters

Three-Terminal Slave Application With a Serial Channel (E87CH = 3SS)

With a similar configuration to *Figure 14*, you can also use a single primary relay with two remote peers for three-terminal applications. With no connection between two of the relays, the single primary relay performs the differential calculation with the data provided by the two remote peer relays. The single primary relay then issues a trip via a direct transfer trip (87DTT) to the remote peer relays.

Four-Terminal Differential Application Over Ethernet Communications

When using Ethernet communications, the SEL-411L can provide 87L differential protection for as many as four terminals.

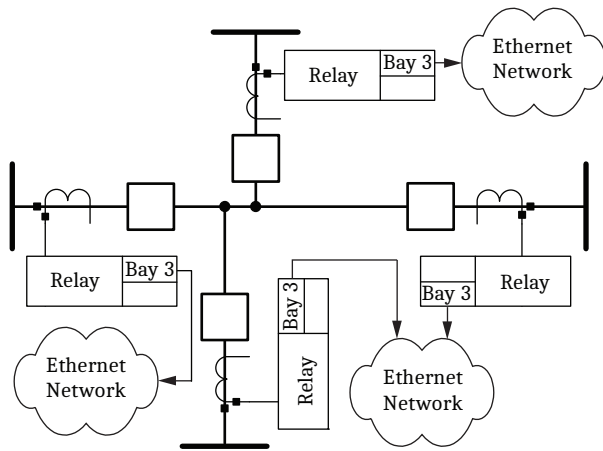

Figure 15 Four-Terminal Ethernet Application

In-Line Transformers

For lines with transformers, the preferred application is to apply separate relays for the line current differential zone and the transformer differential zone, as shown in Figure 16. This allows application of fault location (transformer vs. line faults, exact location for line faults)

and reclosing features. A direct transfer trip from the 87T to the 87L allows fast clearing of transformer zone faults. However, another solution is to use the SEL-411L as a current differential relay for the combined line and transformer zones as shown in Figure 17. This is an economic alternative if neither reclosing nor multiterminal fault locating are necessary.

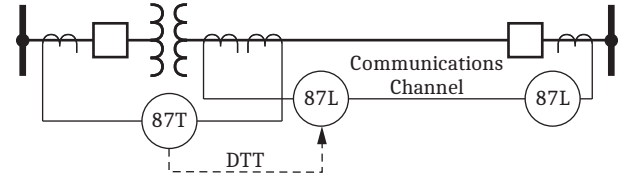

Figure 16 Preferred Application for Lines With Transformer

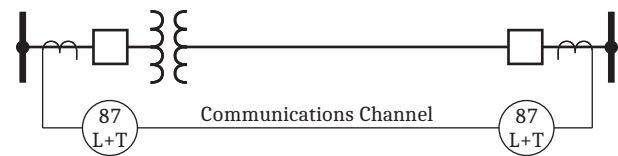

Figure 17 In-Line Transformer With Combined Line and Transformer Current Differential

Additional Features

Front-Panel Display

The LCD shows event, metering, setting, and relay self-test status information. The target LEDs display relay target information as shown in Figure 18.

The LCD is controlled by the navigation pushbuttons (Figure 19), automatic messages the relay generates, and user-programmed analog and digital display points. The rotating display scrolls through alarm points, display points, and metering screens. If none are active, the relay scrolls through displays of the fundamental and rms metering screens. Each display remains for a user-programmed time (1–15 s) before the display continues scrolling. Any message the relay generates because of an alarm condition takes precedence over the rotating display.

Figure 18 and Figure 19 show close-up views of the front panel of the SEL-411L. The front panel includes a 128 x 128 pixel, 3" x 3" LCD screen; LED target indicators; and pushbuttons with indicating LEDs for local control functions. The asserted and deasserted colors for the LEDs are programmable. Configure any of the direct-acting

pushbuttons to navigate directly to any HMI menu item for fast viewing of events, alarm points, display points, or the SER.

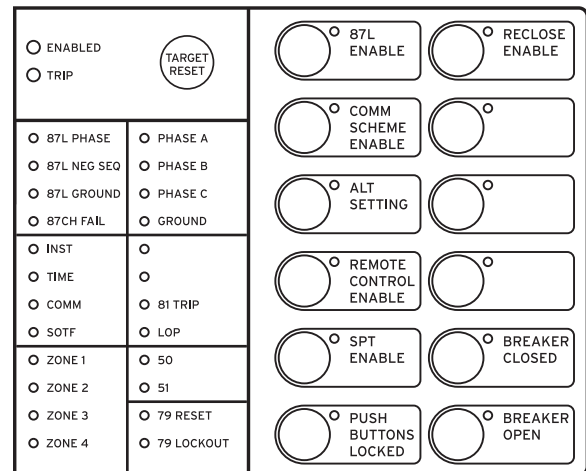

Figure 18 Factory Default Status and Trip Target LEDs (12 Pushbutton, 24 Target LED Option)

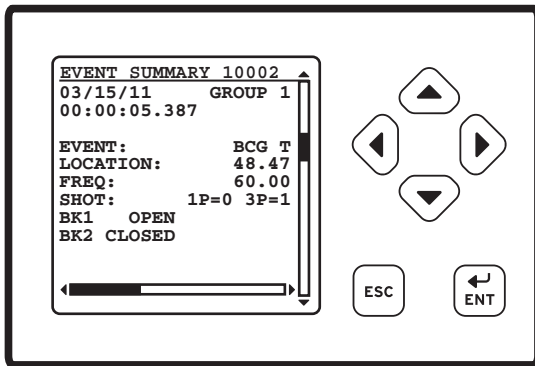

Figure 19 Factory-Default Front-Panel Display and Pushbuttons

Bay Control

The SEL-411L provides dynamic bay one-line diagrams on the front-panel screen with disconnect and breaker control capabilities for user-selectable bay types. You can download the QuickSet interface from selinc.com to obtain additional user-selectable bay types. The bay control can control as many as ten disconnects and two breakers, depending on the one-line diagram selected. Certain one-line diagrams provide status for as many as three breakers and five disconnect switches. Operate disconnects and breakers with ASCII commands, SELOGIC control equations, Fast Operate Messages, and from the one-line diagram. The one-line diagram includes user-configurable apparatus labels and as many as six user-definable analog quantities.

One-Line Bay Diagrams

The SEL-411L offers a variety of preconfigured one-line diagrams for common bus configurations. Once you select a one-line diagram, you can customize the names for all of the breakers, disconnect switches, and buses. Most one-line diagrams contain analog display points. You can set these display points to any of the available analog quantities (including remote 87L currents) with labels, units, and scaling. The SEL-411L updates these values along with the breakers and switch position in real time to give instant status and complete control of a bay. The following diagrams demonstrate some of the preconfigured bay arrangements available in the SEL-411L.

Programmable interlocks help prevent operators from incorrectly opening or closing switches or breakers. The SEL-411L not only prevents operators from making an incorrect control decision, but it can notify and/or alarm upon initiation of an incorrect operation.

Circuit Breaker Operations From the Front Panel

Figure 20–Figure 23 are examples of some of the selectable one-line diagrams in the SEL-411L. Select the one-line diagram from the Bay settings. Additional settings for defining labels and analog quantities are also found in the Bay settings. One-line diagrams are composed of the following:

- Bay names and bay labels
- Busbar and busbar labels
- Breaker and breaker labels
- Disconnect switches and disconnect switch labels
- Analog display points

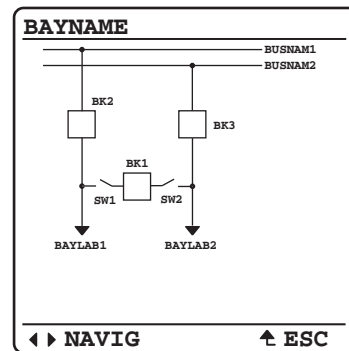

Figure 20 Breaker-and-a-Half

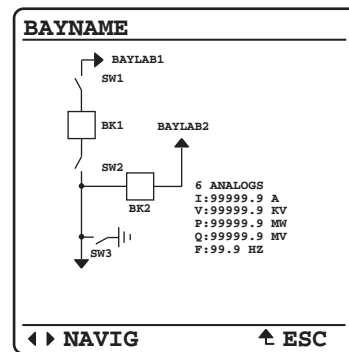

Figure 21 Ring Bus With Ground Switch

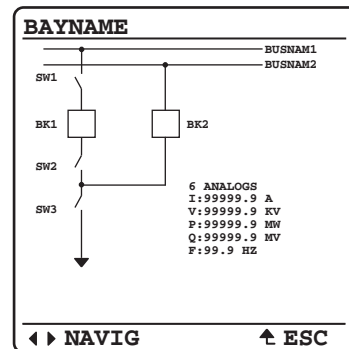

Figure 22 Double Bus/Double Breaker

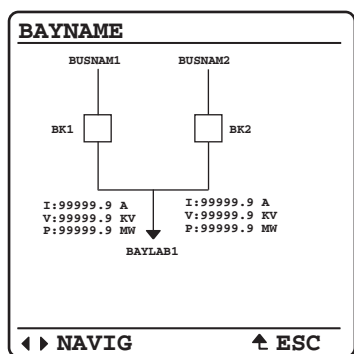

Figure 23 Source Transfer Bus

Figure 24 shows the breaker control screens available when the ENT pushbutton is pressed with the circuit breaker highlighted as shown in Figure 24(a).

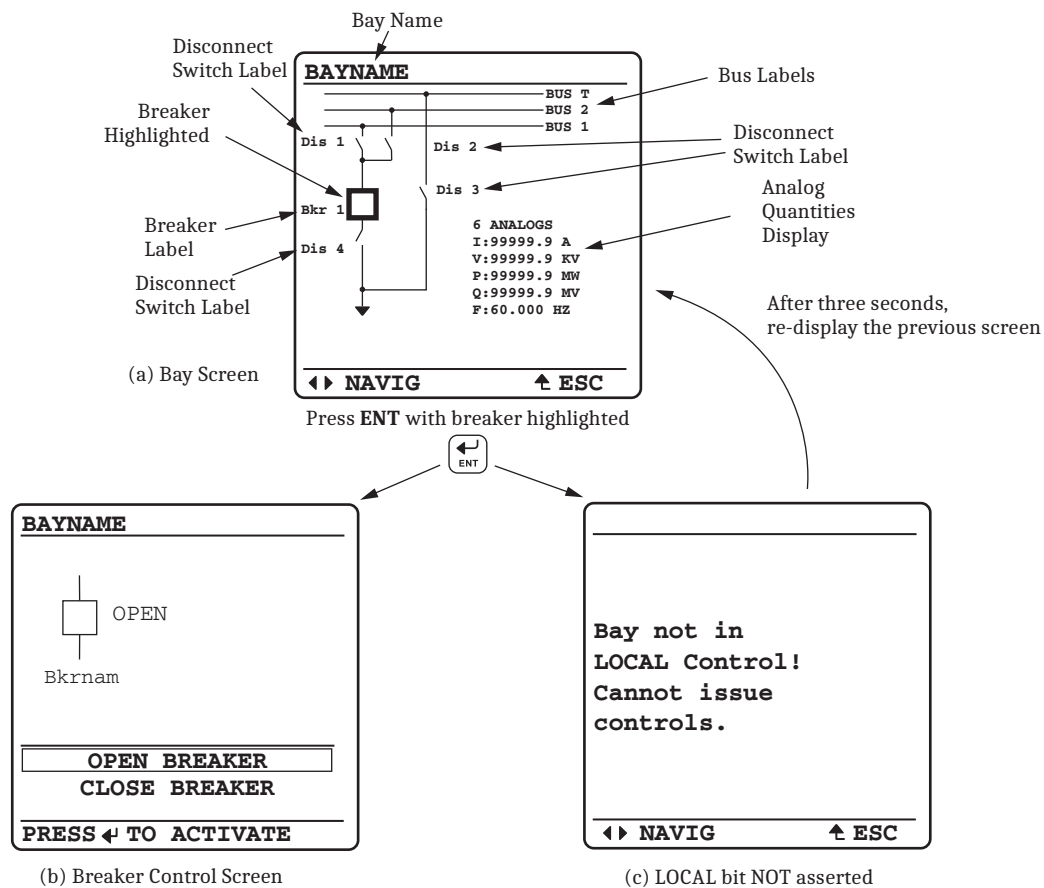

Figure 24 Screens for Circuit Breaker Selection

Rack-Type Breakers Mosaics

The SEL-411L supports the display of rack-type (also referred to as truck-type) circuit breakers. The rack-type breakers have three positions: racked out, test, and racked in. When in the test or racked-in positions, the breaker can be displayed as open or closed. When racked out, no breaker open/close display are available. The rack-type breakers are a display-only functionality and do not impact any circuit breaker control capabilities.

Status and Trip Target LEDs

The SEL-411L includes programmable status and trip target LEDs, as well as programmable direct-action control pushbuttons on the front panel. Figure 18 shows these targets.

The SEL-411L features a versatile front panel that you can customize to fit your needs. Use SELOGIC control equations and slide-in configurable front-panel labels to change the function and identification of target LEDs and operator control pushbuttons and LEDs. The blank

slide-in label set is included with the SEL-411L. You can use templates supplied with the relay or hand label supplied blank labels and print label sets from a printer.

Alarm Points

You can display messages on the SEL-411L front-panel LCD that indicate alarm conditions in the power system. The relay uses alarm points to place these messages on the LCD.

Figure 25 shows a sample alarm points screen. The relay can display as many as 66 alarm points. The relay automatically displays new alarm points while in manual-scrolling mode and in autoscrolling mode. You can configure the alarm points message and trigger it either immediately by using inputs, communications, or conditionally by using powerful SELOGIC control equations. The asterisk next to the alarm point indicates an active alarm. Use the front-panel navigation pushbuttons to clear inactive alarms.

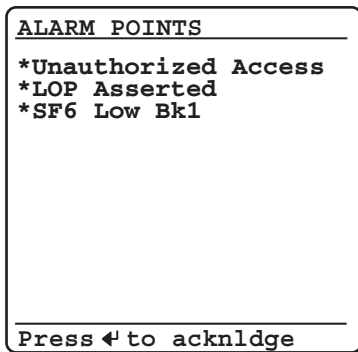

Figure 25 Sample Alarm Points Screen

Advanced Display Points

Create custom screens showing metering values, special text messages, or a mix of analog and status information. Figure 26 shows an example of how you can use display points to show circuit breaker information and current metering. You can create as many as 96 display points. All display points occupy only one line on the display at all times. The height of the line is programmable as either

single or double, as shown in Figure 26. These screens become part of the autoscrolling display when the front panel times out.

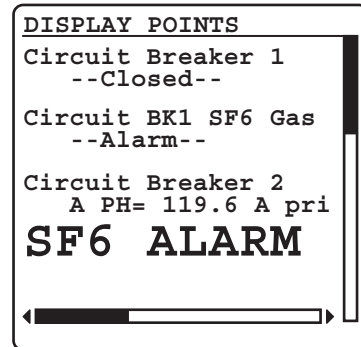

Figure 26 Sample Display Points Screen

Control Inputs and Outputs

The SEL-411L includes positions for as many as three I/O boards. You can select these in the following configurations:

- ▶ Eight optoisolated, independent level-sensitive inputs; 13 standard Form A and two standard Form C contact outputs
- ▶ Eight optoisolated, independent level-sensitive inputs; 13 high-current interrupting Form A outputs and two Standard Form C contact outputs
- ▶ Twenty-four optoisolated, independent level-sensitive inputs; six high-speed, high-current interrupting, polarity dependent Form A contact outputs and two standard Form A outputs
- ▶ Twenty-four optoisolated, independent level-sensitive inputs; eight standard Form A outputs
- ▶ Twenty-four optoisolated, independent level-sensitive inputs; eight high-speed, high-current interrupting, polarity dependent Form A contact outputs

Assign the control inputs for control functions, monitoring logic, and general indication. You can use SELOGIC control equations to program each control output. You can add one I/O board to the 4U chassis, two I/O boards to the 5U chassis, three I/O boards to the 6U chassis, and four I/O boards to the 7U chassis. All control inputs are optoisolated.

Communications Features

See *Specifications on page 32* for specific supported protocols.

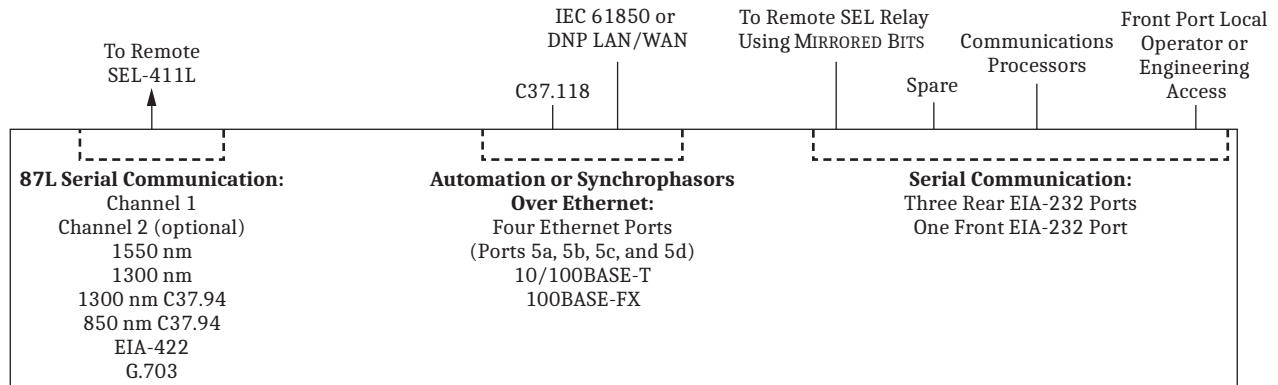

Figure 27 System Functional Overview

The relay offers the following communications features:

- Four independent EIA-232 serial ports.
- Access to event history, relay status, and meter information from the communications ports.
- Password-controlled settings management and automation features.
- SCADA interface capability, including FTP, IEC 61850, DNP3 LAN/WAN (via Ethernet), and DNP3 (via serial port). The relay does not require special communications software. You only need ASCII terminals, printing terminals, or a computer supplied with terminal emulation and a serial communications port.
- Synchrophasor data at 60 message-per-second data format.

Ethernet Card

Use popular Telnet applications for easy terminal communications with SEL relays and other devices. Transfer data at high speeds for fast file uploads. The Ethernet card communicates using FTP applications for easy and fast file transfers.

Communicate with SCADA by DNP3 and other substation IEDs by using IEC 61850 Manufacturing Message Specification (MMS) and GOOSE messaging.

Choose Ethernet connection media options for primary and standby connections:

- 10/100BASE-T twisted pair network
- 100BASE FX fiber-optic network

Telnet and FTP

Use Telnet to access relay settings, metering, and event reports remotely by using the ASCII interface. Use FTP to transfer settings files to and from the relay via the high-speed Ethernet port.

DNP3 LAN/WAN

DNP3 LAN/WAN provides the relay with DNP3 Level 2 Outstation functionality over Ethernet. Configure DNP3 data maps for use with specific DNP3 masters.

PTP

The Ethernet card provides the ability for the relay to accept IEEE 1588 PTPv2 for data time synchronization. PTP support includes the Default, Power System, and Power Utility Automation Profiles. When connected directly to a grandmaster clock providing PTP at 1-second synchronization intervals, the relay can be synchronized to an accuracy of ± 100 ns in the PTP time scale.

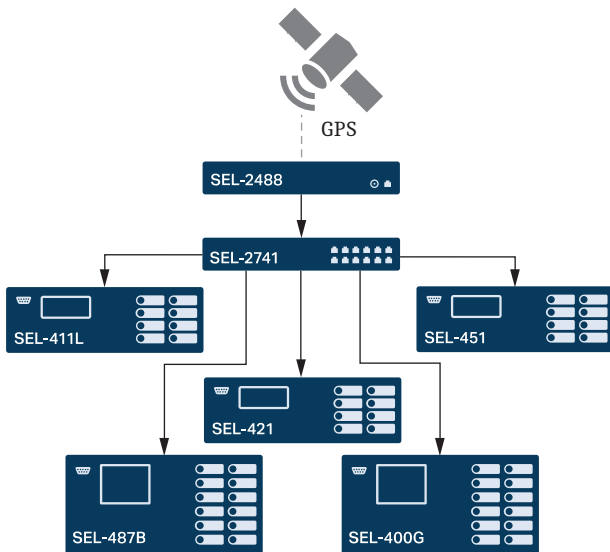

Figure 28 Example PTP Network

SNTP Time Synchronization

Use SNTP to synchronize relays equipped with Ethernet communications to as little as ± 1 ms with no time source delay. Use SNTP as a primary time source, or as a backup to a higher accuracy time input to the relay.

PRP

Use PRP to provide seamless recovery from any single Ethernet network failure, in accordance with IEC 62439-3. The Ethernet network and all traffic are fully duplicated with both copies operating in parallel.

HTTP Web Server

The relay can serve read-only webpages displaying certain settings, metering, and status reports. The web server also allows quick and secure firmware upgrades over Ethernet. As many as four users can access the embedded HTTP server simultaneously.

IEC 61850 Ethernet Communications

IEC 61850 Ethernet-based communication protocols provide interoperability between intelligent devices within the substation. Standardized logical nodes allow interconnection of intelligent devices from different manufacturers for monitoring and control of the substation.

Eliminate system RTUs by streaming monitor and control information from the intelligent devices directly to remote SCADA client devices.

You can order the relay with IEC 61850 protocol for relay monitor and control functions, including:

- ▶ As many as 128 incoming GOOSE messages. You can use the incoming GOOSE messages to control as many as 256 control bits in the relay with <3 ms latency from device to device depending on network design. These messages provide binary control inputs to the relay for high-speed control functions and monitoring.
- ▶ As many as eight outgoing GOOSE messages. Configure outgoing GOOSE messages for Boolean or analog data such as high-speed control and monitoring of external breakers, switches, and other devices. Boolean data are provided with <3 ms latency from device to device depending on network design.
- ▶ IEC 61850 Data Server. The relay equipped with embedded IEC 61850 Ethernet protocol provides data according to predefined logical node objects. Each relay supports as many as seven unbuffered MMS report client associations. Relevant Relay Word bits are available within the logical node data, so status of relay elements, inputs, outputs, or SELOGIC control equations can be monitored.
- ▶ As many as 256 virtual bits. Configure the virtual bits within GOOSE messaging to represent a variety of Boolean values available within the relay. These bits that the relay receives are available for use in SELOGIC control equations.
- ▶ As many as 64 remote analog outputs. Assign the remote analog outputs to virtually any analog quantity available in the relay. You can also use SELOGIC math variables to develop custom analog quantities for assignment as remote analog outputs. Remote analog outputs that use GOOSE messages provide peer-to-peer transmission of analog data. Each relay can receive as many as 256 remote analog inputs and use those inputs as analog quantities within SELOGIC control equations.
- ▶ IEC 61850 standard operating modes. The relay supports Test, Blocked, On, and Off. The relay also supports Simulation mode for added flexibility.

MMS File Services

This service of IEC 61850 MMS provides support for file transfers completely within an MMS session. All relay files that can be transferred via FTP can also be transferred via MMS file services.

MMS Authentication

When enabled via a setting in the Configured IED Description (CID) file, the relay requires authentication from any client requesting to initiate an MMS session.

Architect Software

Use ACCELERATOR Architect SEL-5032 Software to manage the IEC 61850 configuration for devices on the network. This Windows-based software provides easy-to-use displays for identifying and binding IEC 61850 network data among logical nodes that use IEC 61850-compliant CID files. Architect uses CID files to describe the data available in each relay.

Serial Communications

MIRRORED BITS Communications

The SEL patented MIRRORED BITS technology provides bidirectional relay-to-relay digital communication.

Figure 29 shows two relays with SEL-2815 Fiber-Optic Transceivers that use MIRRORED BITS communications. MIRRORED BITS communications can operate simultaneously on any two serial ports. This bidirectional digital communication creates additional outputs (transmitted MIRRORED BITS) and additional inputs (received MIRRORED BITS) for each serial port operating in the MIRRORED BITS communications mode.

Communicated information can include digital, analog, and virtual terminal data. Virtual terminal allows operator access to remote relays through the local relay. You can use this MIRRORED BITS protocol to transfer information between stations to enhance coordination and achieve faster tripping.

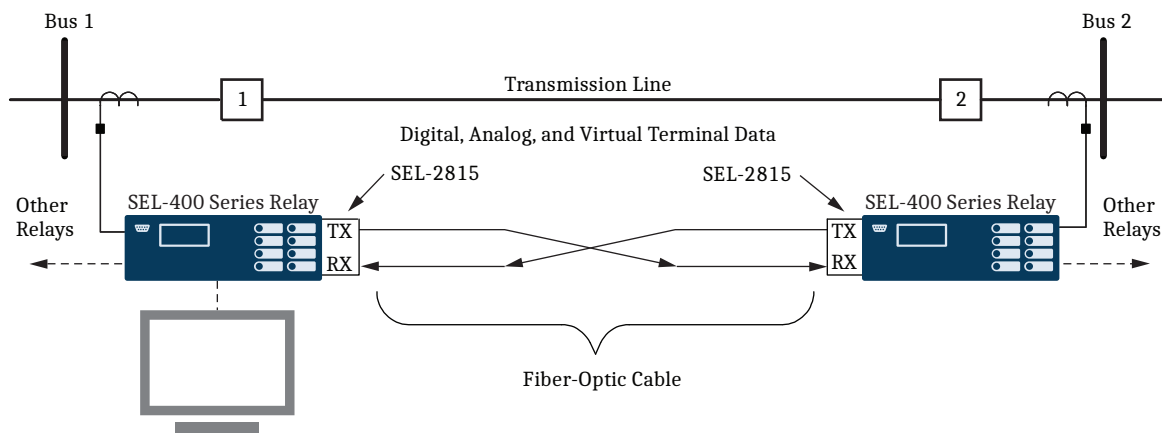

Figure 29 Integral Communication Provides Secure Protection, Monitoring, and Control as Well as Terminal Access to Both Relays Through One Connection

Open Communications Protocols

The relay does not require special communications software. ASCII terminals, printing terminals, or a computer supplied with terminal emulation and a serial communications port are all that is required. *Table 1* lists a brief description of the terminal protocols.

Table 1 Open Communications Protocol (Sheet 1 of 2)

Type	Description
ASCII	Plain-language commands for human and simple machine communications. Use for metering, setting, self-test status, event reporting, and other functions.
Compressed ASCII	Comma-delimited ASCII data reports. Allows external devices to obtain bay data in an appropriate format for direct import into spreadsheets and database programs. Data are checksum protected.
Extended Fast Meter, Fast Operate, and Fast SER	Binary protocol for machine-to-machine communications. Quickly updates communications processors, RTUs, and other substation devices with metering information, bay element, I/O status, time-tags, open and close commands, and summary event reports. Data are checksum protected. Binary and ASCII protocols operate simultaneously over the same communications lines so that control operator metering information is not lost while a technician is transferring an event report.
Ymodem	Support for reading event, settings, and oscillography files.
Optional DNP3 Level 2 Outstation	DNP with point remapping. Includes access to metering data, protection elements, contact I/O, targets, SER, relay summary event reports, and settings groups.
IEEE C37.118	Phasor measurement protocol.
MIRRORED BITS	SEL protocol for exchanging digital and analog information among SEL relays and for use as low-speed terminal connection.

Table 1 Open Communications Protocol (Sheet 2 of 2)

Type	Description
IEC 61850	Ethernet-based international standard for interoperability between intelligent devices in a substation.
PRP	PRP provides redundant Ethernet network capabilities for seamless operation in the event of loss to one network.
Sntp	Ethernet-based Sntp for time synchronization among relays.
FTP and Telnet	Use Telnet to establish a terminal-to-relay connection over Ethernet. Use FTP to move files in and out of the relay over Ethernet.

Automation

Flexible Control Logic and Integration Features

Use the control logic to perform the following:

- Replace traditional panel control switches
- Eliminate remote terminal unit (RTU)-to-bay wiring
- Replace traditional latching relays
- Replace traditional indicating panel lights

Eliminate traditional panel control switches with 64 local control points. Set, clear, or pulse local control points with the front-panel pushbuttons and display. Program the local control points to implement your control scheme via SELOGIC control equations. Use the local control points for such functions as trip testing, enabling/disabling reclosing, and tripping/closing circuit breakers.

Eliminate RTU-to-bay wiring with 64 remote control points per relay. Set, clear, or pulse remote control points via serial port commands. Incorporate the remote control points into your control scheme via SELOGIC control equations. Use remote control points for SCADA-type control operations (e.g., trip, close, settings group selection).

Replace traditional latching relays for such functions as remote control enable with 64 latching control points. Program latch set and latch reset conditions with SELOGIC control equations. Set or reset the latch control points via

control inputs, remote control points, local control points, or any programmable logic condition. The relay retains the states of the latch control points after turning on following a power interruption.

Replace traditional indicating panel lights and switches with as many as 24 latching target LEDs and as many as 12 programmable pushbuttons with LEDs. Define custom messages (i.e., BREAKER OPEN, BREAKER CLOSED, RECLOSER ENABLED) to report power system or relay conditions on the large format LCD. Control displayed messages with SELOGIC control equations by driving the LCD via any logic point in the relay.

SELOGIC Control Equations With Expanded Capabilities and Aliases

Expanded SELOGIC control equations put relay logic in the hands of the engineer. Assign inputs to suit your application, logically combine selected bay elements for various control functions, and assign outputs to your logic functions.

Programming SELOGIC control equations consists of combining relay elements, inputs, and outputs with SELOGIC control equation operators (*Table 2*). Any element in the Relay Word can be used in these equations. For complex or unique applications, these expanded SELOGIC functions allow superior flexibility.

Table 2 SELOGIC Control Equation Operators

Operator Type	Operators	Comments
Boolean	AND, OR, NOT	Allows combination of measuring units.
Edge Detection	F_TRIG, R_TRIG	Operates at the change of state of an internal function.
Comparison	>, >=, =, <=, <, <>	
Arithmetic	+, -, *, /	Uses traditional math functions for analog quantities in an easily programmable equation.
Numerical	ABS, SIN, COS, LN, EXP, SQRT, LOG	
Precedence Control	()	Allows multiple and nested sets of parentheses.
Comment	#, (* *)	Provides for easy documentation of control and protection logic.

Use the relay alias capability to assign more meaningful names to analog and Boolean quantities. This improves the readability of customized programming. Use as many as 200 aliases to rename any digital or analog quantity. The following is an example of possible applications of SELOGIC control equations that use aliases.

```

=>>SET T <Enter>
1: PMV01,THETA
(assign the alias "THETA" to math variable PMV01)

2: PMV02,TAN
(assign the alias "TAN" to math variable PMV02)

=>>SET L <Enter>
1: # CALCULATE THE TANGENT OF THETA
2: TAN:=SIN(THETA)/COS(THETA)
(use the aliases in an equation)

```

Add programmable control functions to your relay and automation systems. New functions and capabilities enable using analog values in conditional logic statements. The following are examples of possible applications of SELOGIC control equations with expanded capabilities.

- Emulate a motor-driven reclose timer, including stall, reset, and drive-to-lockout conditions.
- Scale analog values for SCADA retrieval.
- Initiate remedial action sequence based on load flow before fault conditions.
- Interlock breakers and disconnect switches.
- Restrict breaker tripping in excessive duty situations without additional relays.
- Hold momentary change-of-state conditions for SCADA polling.

Metering and Monitoring

Access a range of useful information in the relay with the metering function. Metered quantities include fundamental primary and secondary current and voltage magnitudes and angles for each terminal. RMS voltage and

current metering is also provided. Fundamental phase and real and reactive power, per-phase voltage magnitude, angle, and frequency are displayed in the metering report for applications that use the relay voltage inputs.

Table 3 Metering Capabilities (Sheet 1 of 2)

Capabilities	Description
Instantaneous Quantities	
Voltages $V_{A,B,C} (Y)$, $V_{A,B,C} (Z)$, $V_{\phi\phi}$, 3V0, V1, 3V2	0–300 V with phase quantities for each of the six voltage sources available as separate quantities.
Currents $I_{A,B,C} (W)$, $I_{A,B,C} (X)$, I_{AL} , I_{BL} , I_{CL} , (combined currents), I_{GL} , I_{LL} , $3I_{2L}$ (combined currents)	Phase quantities for each of the two current sources available as separate quantities or combined as line quantities.
Differential Metering	
Currents $I_{A,B,C}$, I_1 , $3I_2$, $3I_0$	Local terminal/all Remote Terminals
Differential Current $I_{A,B,C}$, I_1 , $3I_2$, $3I_0$	Local terminal/all Remote terminals
Alpha Plane k alpha	Alpha plane ratio Alpha plane angle
Power/Energy Metering Quantities	
MW, MWh, MVAR, MVARh, MVA, PF, single-phase and three-phase	Available for each input set and as combined quantities for the line.
Demand/Peak Demand Metering	
$I_{A,B,C}$, $3I_2$, $3I_0$	Thermal or rolling interval demand and peak demand.
MW, MVAR, MVA, single-phase	Thermal or rolling interval demand and peak demand.
MW, MVAR, MVA, three-phase	Thermal or rolling interval demand and peak demand.

Table 3 Metering Capabilities (Sheet 2 of 2)

Capabilities	Description
Synchrophasors	
Voltages (Primary Magnitude, Angle) $V_{A, B, C} (Y), V_{A, B, C} (Z)$	Primary phase quantities (kV) for each of the six voltage sources available.
Currents $I_{A, B, C} (W), I_{A, B, C} (X)$	Primary phase quantities (A) for each of the six voltage sources available.
Frequency FREQ dF/dT	Frequency (Hz) as measured by frequency source potential inputs. Rate-of-change in frequency (Hz/s).

Event Reporting and SER

Event reports and SER features simplify post-fault analysis and help improve your understanding of both simple and complex protective scheme operations. These features also aid in testing and troubleshooting relay settings and protective schemes.

Oscilloscopy and Event Reporting

In response to a user-selected internal or external trigger, the voltage, current, and element status information contained in each event report confirms relay, scheme, and system performance for every fault. The relay provides sampling rates as fast as 8 kHz for analog quantities in a COMTRADE file format, as well as eight-sample-per-cycle and four-sample-per-cycle event reports. The relay stores as much as 3 seconds of 8 kHz event data. The relay supports inclusion of user-configurable analogs in the events. Reports are stored in nonvolatile memory. Relay settings operational in the relay at the time of the event are appended to each event report.

Each relay provides event reports for analysis with software such as SEL-5601-2 SYNCHROWAVE[®] Event Software. With SYNCHROWAVE Event, you can display events from several relays to make the fault analysis easier and more meaningful. Because the different relays time-stamp the events with values from their individual clocks, be sure to time synchronize the relay with an IRIG-B clock input or PTP source to use this feature.

Event Summary

Each time the relay generates a standard event report, it also generates a corresponding event summary. This is a concise description of an event that includes the following information:

- Relay/terminal identification
- Event date and time
- Event type

- Event number
- Time source
- Active settings group
- Targets asserted during the fault
- Current magnitudes and angles for each terminal
- Pre-fault and fault calculated zero- and negative-sequence currents
- Voltage magnitudes and angles
- Terminals tripped for this fault
- Recloser shot count at time of trigger (if applicable)
- Fault location (if applicable)
- Breaker status (open/close)

With an appropriate setting, the relay sends an event summary in ASCII text automatically to one or more serial ports each time an event report is triggered.

SER

Use this feature to gain a broad perspective of relay element operation. Items that trigger an SER entry are selectable and can include as many as 250 monitoring points, such as I/O change-of-state and element pickup/dropout. The relay SER stores the latest 1000 events.

Analog Signal Profiling

The relay provides analog signal profiling for as many as 20 analog quantities. Select any analog quantity measured or calculated by the relay for analog signal profiling. You can select signal sampling rates of 1, 5, 15, 30, and 60 minutes through settings. The analog signal profile report provides a comma-separated variable (CSV) list that you can load into any spreadsheet or database for analysis and graphical display.

SELOGIC enable/disable functions can start and stop signal profiling based on Boolean or analog comparison conditions.

Substation Battery Monitor for DC Quality Assurance

The relay measures and reports the substation battery voltage for up to two battery systems. The SEL-411L, SEL-421, SEL-451 support two battery monitors while the SEL-487B, SEL-487E, and SEL-487V support one. Each battery monitor supports programmable threshold comparators and associated logic provides alarm and control for batteries and chargers. The relay also provides dual ground detection. Monitor dc system status alarms with an SEL communications processor and trigger messages, telephone calls, or other actions.

The measured dc voltage is reported in the METER display via serial port communications, on the LCD, and in the event report. Use the event report data to see an oscillographic display of the battery voltage. Monitor the substation battery voltage drops during trip, close, and other control operations.

Breaker Contact Wear Monitoring

Circuit breakers experience mechanical and electrical wear during each operation. Effective scheduling of breaker maintenance takes into account the manufacturer's published data of contact wear versus interruption levels and operation count.

- ▶ Every time the breaker trips, the relay integrates interrupted current. When the result of this integration exceeds the threshold set by the breaker wear curve (*Figure 30*), the relay can alarm via an output contact or the optional front-panel display. With this information, you can schedule breaker maintenance in a timely, economical fashion.
- ▶ The relay monitors last and average mechanical and electrical interruption time per pole. You can easily determine if operating time is increasing beyond reasonable tolerance and then schedule proactive breaker maintenance. You can activate an alarm point if operation time exceeds a preset value.

The relay also monitors breaker motor run time, pole discrepancy, and breaker inactivity.

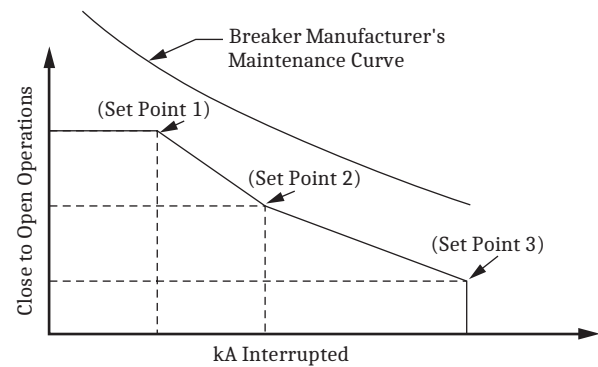

Figure 30 Breaker Contact Wear Curve and Settings

Traveling-Wave Fault Location

When high-accuracy IRIG-B time is available, the SEL-411L uses a type D traveling-wave algorithm to compute fault location. A dedicated analog-to-digital converter samples both sets of three-phase currents connected to the relay terminals (IAW, IBW, ICW, IAX, IBX, ICX) at 1.5625 MHz. Each SEL-411L in a two-terminal scheme extracts high frequency content and, based on a setting selection, uses one set of three-phase currents for fault location calculation. When an 87L or communications-assisted trip occurs, each relay terminal exchanges data along with a time stamp, and the SEL-411L relays then use this information to calculate a fault location. *Figure 31* shows the traveling waves captured at each terminal.

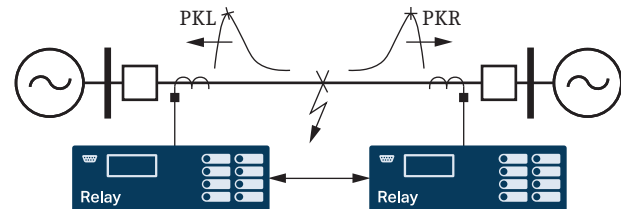

Figure 31 Relays Exchanging Peak Information Via 87L Communications Channel

In installations where the differential communications channel is not available, an SEL-411L can compute fault location manually by using the traveling-wave COM-TRADE files it retrieves from either terminal.

The SEL-411L displays all fault location estimates (traveling-wave and one impedance-based).

Diagrams and Dimensions

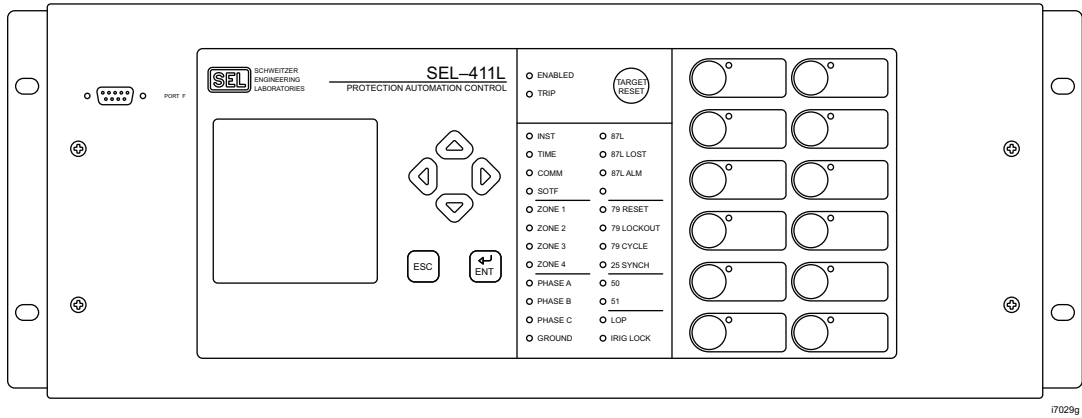

Figure 32 4U Front Panel, Rack-Mount Option

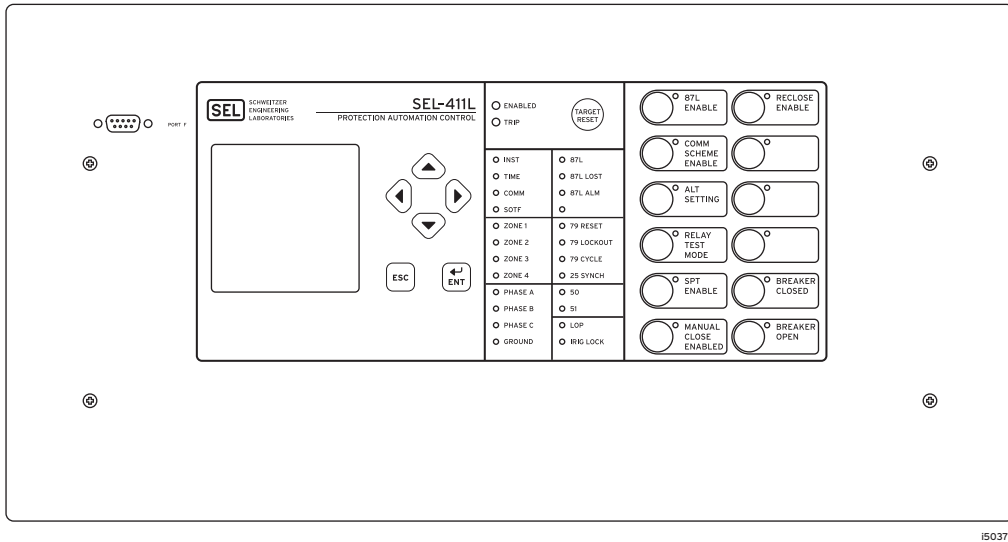

Figure 33 5U Front Panel, Panel-Mount Option

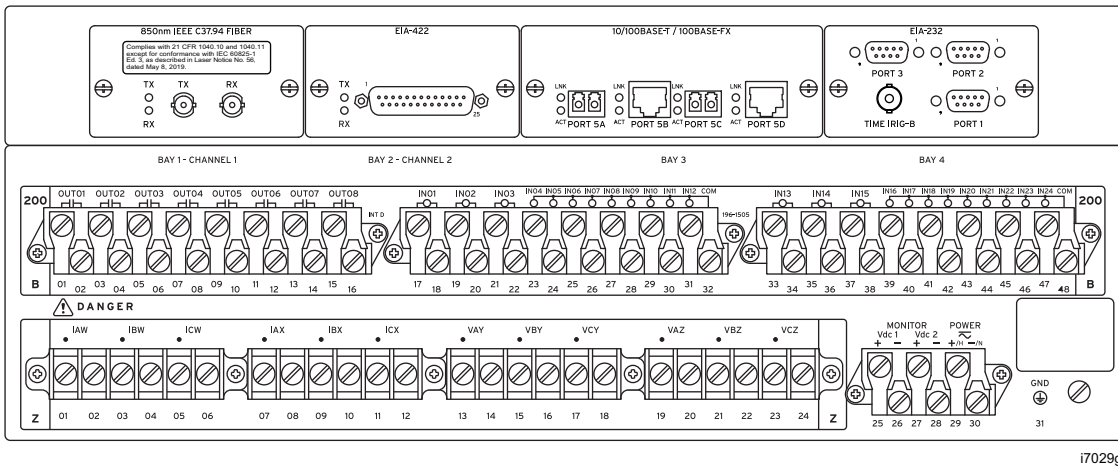
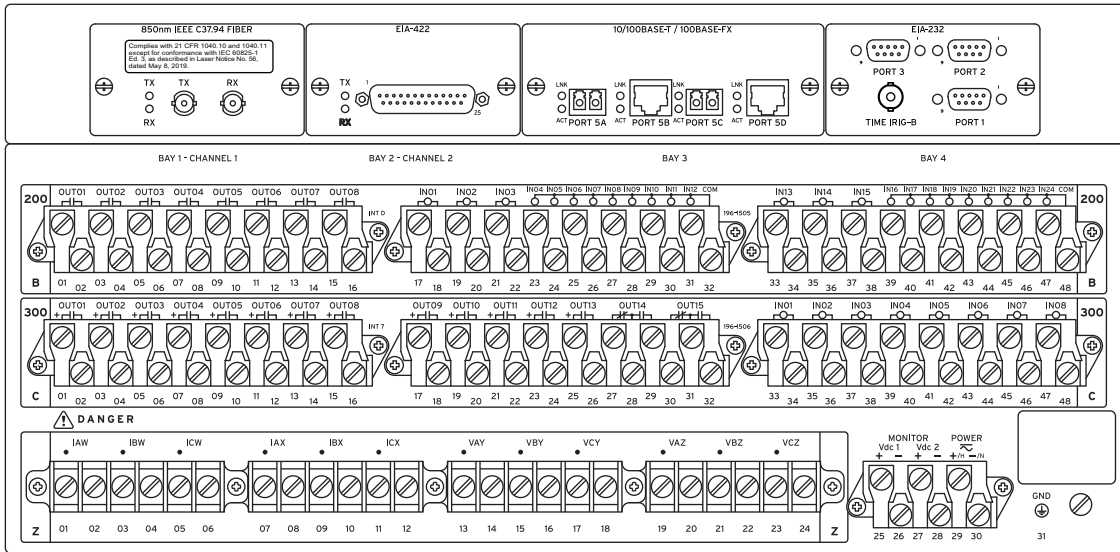
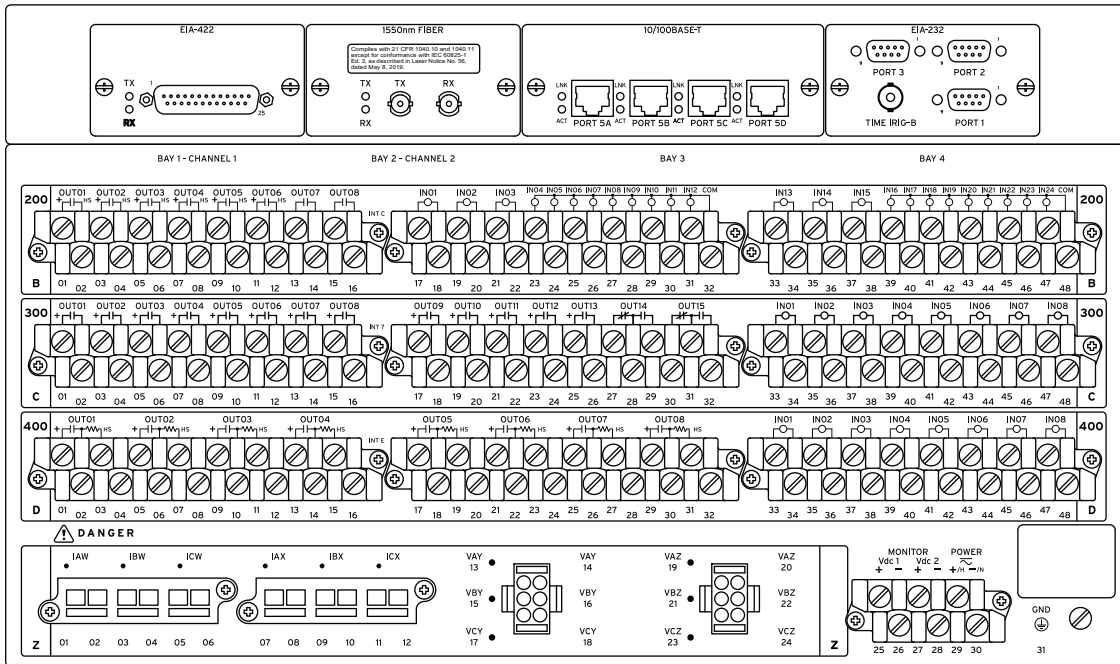

Figure 34 4U Rear Panel, Terminal Block, One (INTD) I/O Board Option



i7031g

Figure 35 5U Rear Panel, Terminal Block, Two (INTD and INT7) I/O Board Option



i6287a

Figure 36 6U Rear Panel, Connectorized Terminal Block, Three (INTC, INT7, and INTE) I/O Board Option

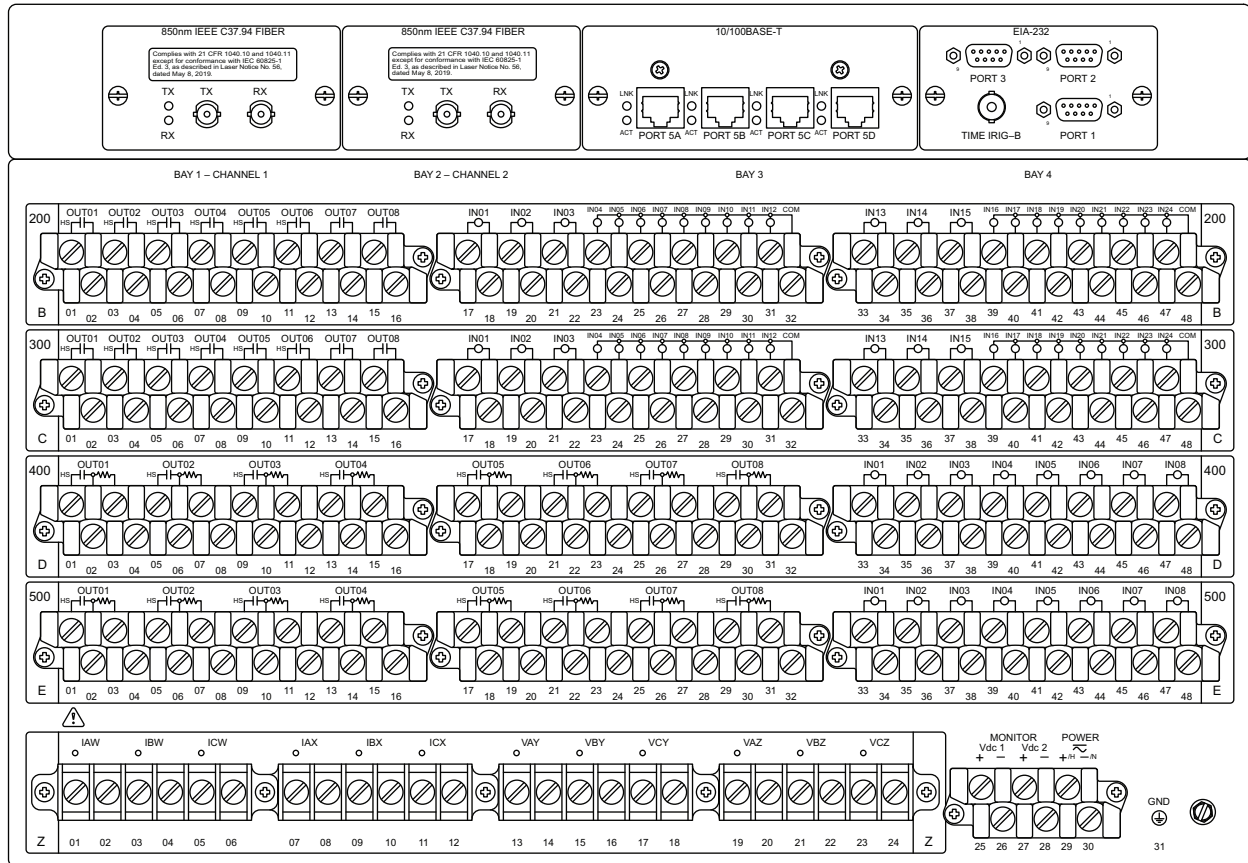

i7240a

Figure 37 7U Rear Panel, Terminal Block, Four (Two INT4 and Two INT8) I/O Board Option

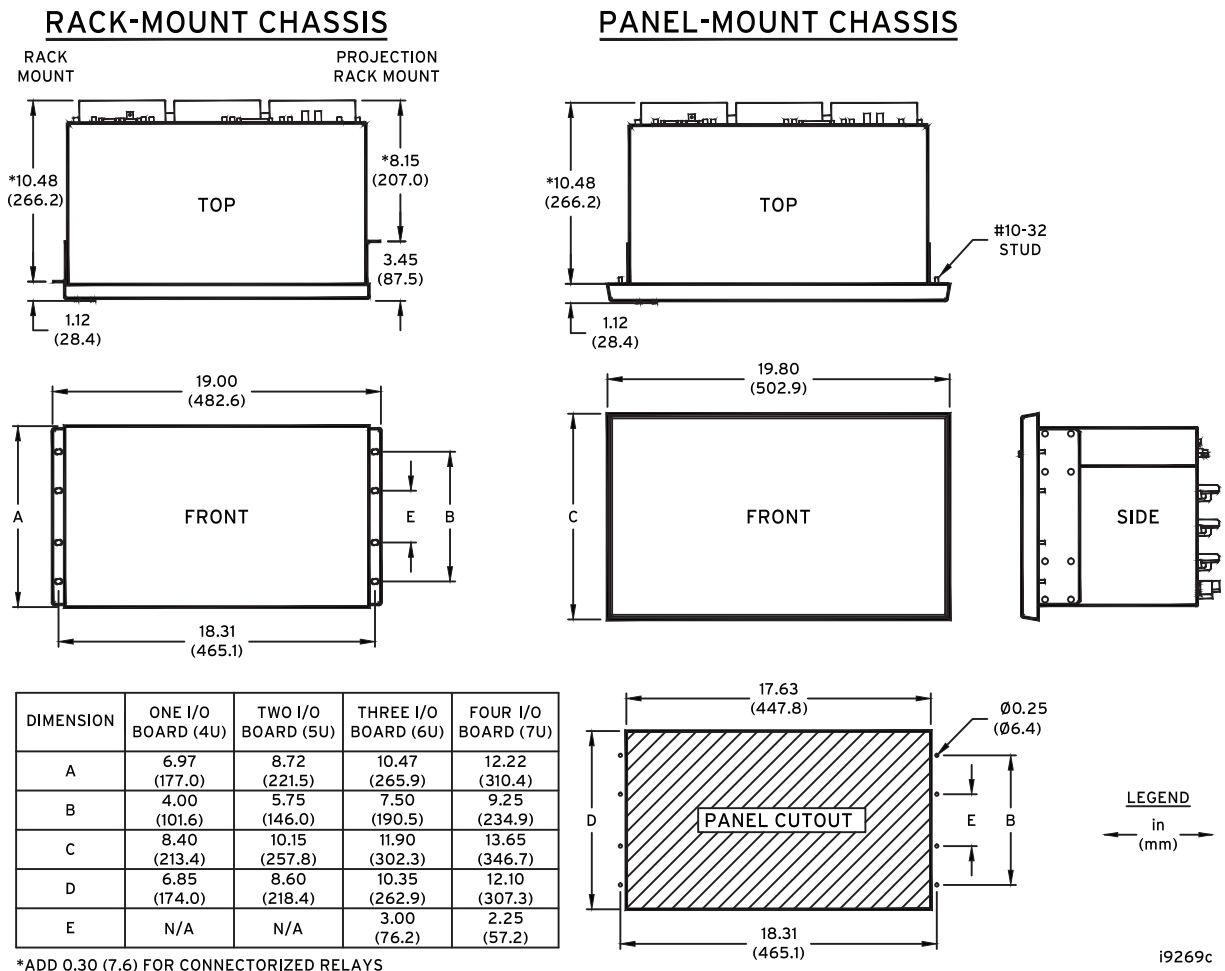

Figure 38 4U, 5U, 6U, and 7U Chassis Dimensions

Models and Options

The SEL-411L allows you to simplify procurement, protection engineering, panel design and manufacturing, and spare part management. This data sheet is applicable to the SEL-411L-0, -1, -A, and -B relays. Not all the features, functions, and applications detailed in this data sheet apply to all variants of the SEL-411L. *Table 5* details which features, functions, and applications are supported by each of the SEL-411L models.

Consider the following options when ordering and configuring the relay.

- Firmware options
 - See *Table 5*
- Chassis size
 - 4U, 5U, 6U, and 7U (U is one rack unit—1.75 in or 44.45 mm)

Table 4 Interface Board Information (Sheet 1 of 2)

Board Name	Inputs	Description	Outputs	Description
INT2	8	Optoisolated, independent, level-sensitive	13 2	Standard Form A Standard Form C
INT4	18 6	Two sets of 9 common optoisolated, level-sensitive Optoisolated, independent, level-sensitive	6 2	High-speed, high-current interrupting, Form A Standard Form A
INT7	8	Optoisolated, independent, level-sensitive	13 2	High-current interrupting, Form A Standard Form C
INT8	8	Optoisolated, independent, level-sensitive	8	High-speed, high-current interrupting, Form A

Table 4 Interface Board Information (Sheet 2 of 2)

Board Name	Inputs	Description	Outputs	Description
INTC	18	Two sets of 9 common optoisolated, level-sensitive	6	High-speed, high-current interrupting (polarity sensitive), Form A
	6	Optoisolated, independent, level-sensitive	2	Standard Form A
INTD	18	Two sets of 9 common optoisolated, level-sensitive	8	Standard Form A
	6	Optoisolated, independent, level-sensitive		
INTE	8	Optoisolated, independent, level-sensitive	8	High-speed, high-current interrupting (polarity sensitive), Form A

- Chassis orientation and type
 - Horizontal rack mount
 - Horizontal panel mount
 - Vertical rack mount
 - Vertical panel mount
- Power supply
 - 24–48 Vdc
 - 48–125 Vdc or 110–120 Vac
 - 125–250 Vdc or 120–240 Vac
- Secondary inputs
 - 1 A nominal or 5 A nominal CT inputs
 - 300 V phase-to-neutral wye configuration PT inputs
- Ethernet card options
 - Ethernet card with port combinations of:
 - Four copper (10BASE-T/100BASE-TX)
 - Four fiber (100BASE-FX)
 - Two sets:
 - Copper (10BASE-T/100BASE-TX)
 - Fiber (100BASE-FX)

- Communications protocols
 - Complete group of SEL protocols (SEL ASCII, SEL Compressed ASCII, SEL Settings File Transfer, SEL Fast Meter, SEL Fast Operate, SEL Fast SER, RTDs, Enhanced MIRRORING BITS Communications), and Synchrophasors (SEL Fast Message and IEEE C37.118 format), plus DNP3
 - Complete group of SEL protocols, Synchrophasors (SEL Fast Message and IEEE C37.118 format), plus DNP3 and IEC 61850
 - 87L (line protection)
- Connector type
 - Screw-terminal block inputs
 - Connectorized

Contact the SEL factory or your local Technical Service Center for particular part number and ordering information (see *Technical Support on page 41*). You can also view the latest part number and ordering information on the SEL website at selinc.com.

Table 5 shows the firmware options available in the SEL-411L.

Table 5 Firmware Options^a (Sheet 1 of 3)

SEL-411L Firmware Options	SEL-411L-0	SEL-411L-1	SEL-411L-A	SEL-411L-B
Applications				
Differential Protection				
Three Terminal (Serial)	•	•	•	•
Four Terminal (Ethernet)	•	•		
Distance Protection	•	•	•	•
Pilot Protection—Directional and Distance	•	•	•	•
Single-Pole Tripping	•	•		•
Series-Compensated Lines	•	•	•	•
Terminal Arrangement				
Dual Breaker	•	•		
Single Breaker	•	•	•	•

Table 5 Firmware Options^a (Sheet 2 of 3)

SEL-411L Firmware Options	SEL-411L-0	SEL-411L-1	SEL-411L-A	SEL-411L-B
Major Protection Functions				
Line Current Differential	•	•	•	•
Phase and Ground Distance—Mho	•	•	•	•
Phase and Ground Distance—Quadrilateral	•	•	•	•
Series-Compensation Line Logic		•		
Directional (Phase, Negative-Sequence, Zero-Sequence)	•	•	•	•
High-Speed Distance and High-Speed Directional		•		
Independent and Common Step-Distance Timers	•	•	•	•
Pilot Protection (POTT, PUTT, DCB, DCUB, DTT)	•	•	•	•
Instantaneous Overcurrent (Phase, Negative-Sequence, Zero-Sequence)	•	•	•	•
Inverse-Time Overcurrent (Phase, Negative-Sequence, Zero-Sequence)	•	•	•	•
Directional Overcurrent (Phase, Negative-Sequence, Zero-Sequence)	•	•	•	•
Switch-Onto-Fault	•	•	•	•
Breaker Failure				
Single Breaker	•	•	•	•
Dual Breaker	•	•		
Over- and Undervoltage	•	•	•	•
Over- and Underpower	•	•	•	•
Over- and Underfrequency	•	•	•	•
Thermal	•	•	•	•
Out-of-Step Tripping	•	•	•	•
Broken Conductor Detection		•		
Supervisory Elements				
Loss of Potential	•	•	•	•
Load Encroachment	•	•	•	•
CCVT Transient Detection	•	•	•	•
Out-of-Step Blocking				
Conventional (Setting)	•	•	•	•
Zero Setting	•	•		
Synchronism Check	•	•	•	•
Control				
Automatic Reclosing				
Single Breaker (Three-Pole Tripping)	•	•	•	•
Single Breaker (Single- and Three-Pole Tripping)	•	•		•
Dual Breaker (Three-Pole Tripping)	•	•		
Dual Breaker (Single- and Three-Pole Tripping)	•	•		
One-Line Bay Diagrams	•	•	•	•
Freeform SELOGIC Control Equations	•	•	•	•
Nonvolatile Latch Control Switches	•	•	•	•
SELOGIC Remote and Local Control Switches	•	•	•	•
Programmable Math Operations	•	•	•	•

Table 5 Firmware Options^a (Sheet 3 of 3)

SEL-411L Firmware Options	SEL-411L-O	SEL-411L-1	SEL-411L-A	SEL-411L-B
Fault Locating, Monitoring and Recording				
Fault Locating				
Single-Ended Impedance	•	•	•	•
Multi-Ended Impedance	•	•	•	•
Multi-Ended Traveling Wave		•		
Broken Conductor		•		
Breaker Wear Monitor				
Single Breaker	•	•	•	•
Dual Breaker	•	•		
Substation Battery Monitor				
Single Battery System	•	•	•	•
Double Battery System	•	•		
Event Recorder (DFR)	•	•	•	•
Sequential Event Recorder (SER)	•	•	•	•
High-Accuracy Metering	•	•	•	•
SCADA/HMI Integration and Protocols				
SEL ASCII, Fast Meter, Fast SER	•	•	•	•
DNP3—Serial	•	•	•	•
DNP3 LAN/WAN	•	•	•	•
Synchrophasors (IEEE C37.118)	•	•		•
IEC 61850 Edition 2.0	*	*	•	•
Parallel Redundancy Protocol (PRP)	*	*	•	•
IEEE 1588 Precision Time Protocol Version 2 (PTPv2)	*	*	•	•
Digital Protection Signaling				
Direct Fiber	*	*	*	*
SEL MIRRORRED BITS Communications	•	•	•	•
IEEE C37.94	*	*	*	*
G.703	*	*	*	*
EIA-422	*	*	*	*
Miscellaneous				
High-Speed High-Current Interrupting Output Contacts	*	*	*	*
Software Invertible CT and PT Polarities	•	•	•	•
Configurable Display Points	•	•	•	•
Configurable Pushbuttons	•	•	•	•
Configurable Targets	•	•	•	•
Printable Labels	•	•	•	•

^a • = Standard feature

* = Optional feature

Table 6 summarizes the communications cards options (see Section 2: Installation in the SEL-411L Instruction Manual for more information).

Table 6 Communications Cards Options (Excluding EIA-232 Card) (Sheet 1 of 2)

Card	Description
<p style="text-align: center;">10/100BASE-T</p> 	<p>Communication: 10/100BASE-T, Ethernet Communications Medium: copper Connector Type: RJ45 Bay Position: Bay 3 Model Option Table Digit: 6</p>
<p style="text-align: center;">100BASE-FX</p> 	<p>Communication: 100BASE-FX, Ethernet Communications Medium: fiber Connector Type: LC Bay Position: Bay 3 Model Option Table Digit: 7</p>
<p style="text-align: center;">10/100BASE-T / 100BASE-FX</p> 	<p>Communication: 100BASE-FX/10/100BASE-T, Ethernet Communications Medium: fiber/copper Connector Type: LC/RJ45 Bay Position: Bay 3 Model Option Table Digit: 8</p>
<p style="text-align: center;">EIA-422</p> 	<p>87L Communication: EIA-422, Serial Communications Medium: copper Connector Type: DB-25 Bay Position: Bay 1 or 2 Model Option Table Digit: A</p>
<p style="text-align: center;">G.703</p> 	<p>87L Communication: G.703, Serial Communications Medium: copper Connector Type: DB-25 Bay Position: Bay 1 or 2 Model Option Table Digit: B</p>
<p style="text-align: center;">850nm IEEE C37.94 FIBER</p> 	<p>87L Communication: 850 nm IEEE C37.94, Serial Communications Medium: fiber Connector Type: ST Bay Position: Bay 1 or 2 Model Option Table Digit: C</p>

Table 6 Communications Cards Options (Excluding EIA-232 Card) (Sheet 2 of 2)

Card	Description
 <p>1300nm FIBER</p>	<p>87L Communication: 1300 nm, Serial Communications Medium: fiber Connector Type: ST Bay Position: Bay 1 or 2 Model Option Table Digit: D</p>
 <p>1550nm FIBER</p>	<p>87L Communication: 1550 nm, Serial Communications Medium: fiber Connector Type: ST Bay Position: Bay 1 or 2 Model Option Table Digit: E</p>
 <p>1300nm IEEE C37.94 FIBER</p>	<p>87L Communication: 1300 nm IEEE C37.94, Serial Communications Medium: fiber Connector Type: ST Bay Position: Bay 1 or 2 Model Option Table Digit: H</p>

Specifications

Compliance

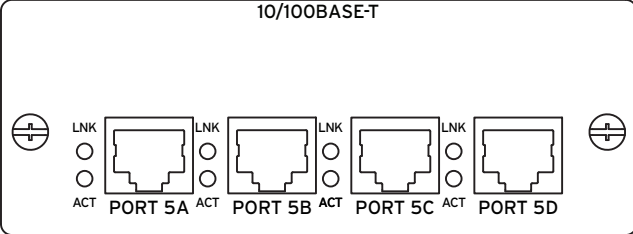
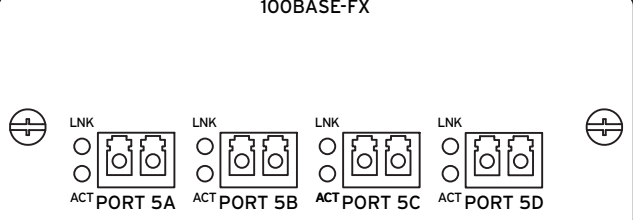
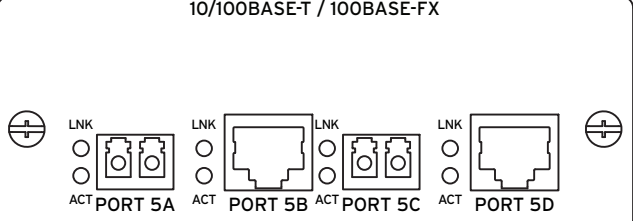
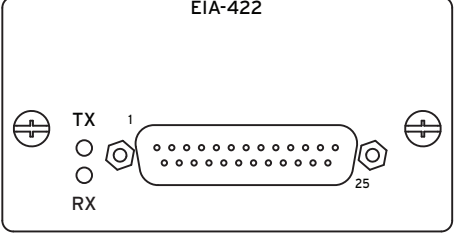
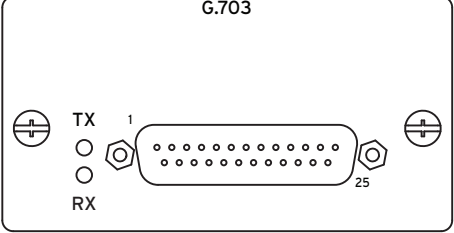
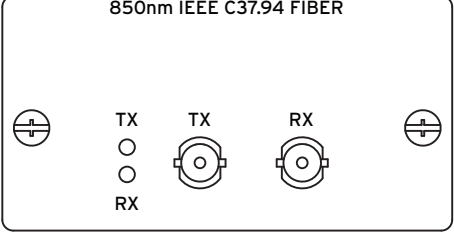
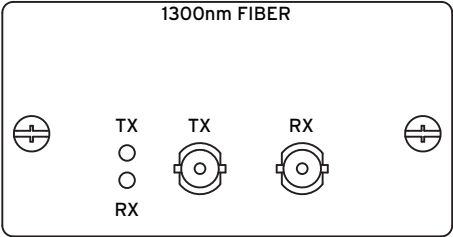
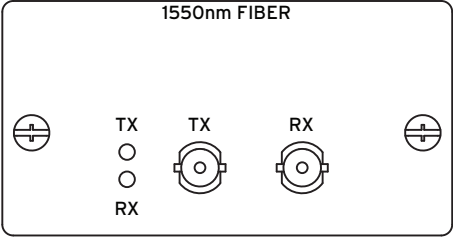
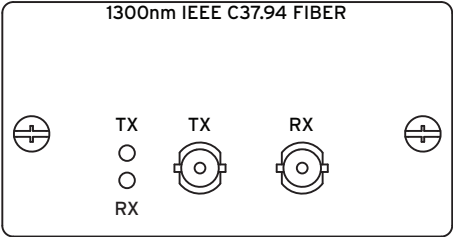
Designed and manufactured under an ISO 9001 certified quality management system

FCC Compliance Statement

This equipment has been tested and found to comply with the limits for a Class A digital device, pursuant to part 15 of the FCC Rules. These limits are designed to provide reasonable protection against harmful interference when the equipment is operated in a commercial environment. This equipment generates, uses, and can radiate radio frequency energy and, if not installed and used in accordance with the instruction manual, may cause harmful interference in which case the user will be required to correct the interference at his own expense.

UL Listed to U.S. and Canadian safety standards
 (File E212775; NRGU, NRGU7)

CE Mark

General

AC Analog Inputs

Sampling Rate: 8 kHz

AC Current Inputs (Secondary Circuits)

Current Rating (With DC Offset at X/R = 10, 1.5 cycles)

1 A Nominal: 18.2 A
 5 A Nominal: 91 A

Continuous Thermal Rating

1 A Nominal: 3 A
 4 A (+55°C)
 5 A Nominal: 15 A
 20 A (+55°C)

Saturation Current (Linear) Rating

1 A Nominal: 20 A
 5 A Nominal: 100 A

A/D Current Limit (Peak)

1 A Nominal: 49.5 A
 5 A Nominal: 247.5 A

One-Second Thermal Rating

1 A Nominal: 100 A
 5 A Nominal: 500 A

One-Cycle Thermal Rating (Peak)

1 A Nominal: 250 A
 5 A Nominal: 1250 A

Burden Rating

1 A Nominal: ≤0.1 VA @ 1 A
 5 A Nominal: ≤0.5 VA @ 5 A

AC Voltage Inputs

Three-phase, four-wire (wye) connections are supported.

Rated Voltage Range: 55–250 V_{LN}

Operational Voltage Range: 0–300 V_{LN}
 Ten-Second Thermal Rating: 600 Vac
 Burden: ≤0.1 VA @ 125 V

Frequency and Rotation

System Frequency: 50/60 Hz
 Phase Rotation: ABC or ACB
 Nominal Frequency Rating: 50 ±5 Hz
 60 ±5 Hz
 Frequency Tracking (Requires PTs): Tracks between 40.0–65.0 Hz
 Below 40 Hz = 40 Hz
 Above 65.0 Hz = 65 Hz
 Maximum Slew Rate: 15 Hz per s

Power Supply

24–48 Vdc

Rated Voltage: 24–48 Vdc
 Operational Voltage Range: 18–60 Vdc
 Vdc Input Ripple: 15% per IEC 60255-26:2013
 Interruption: 20 ms @ 24 Vdc, 100 ms @ 48 Vdc
 per IEC 60255-26:2013
 Burden: <35 W

48–125 Vdc or 110–120 Vac

Rated Voltage: 48–125 Vdc, 110–120 Vac
 Operational Voltage Range: 38–140 Vdc
 85–140 Vac
 Rated Frequency: 50/60 Hz
 Operational Frequency Range: 30–120 Hz
 Vdc Input Ripple: 15% per IEC 60255-26:2013
 Interruption: 14 ms @ 48 Vdc, 160 ms @ 125 Vdc
 per IEC 60255-26:2013
 Burden: <35 W, <90 VA

125–250 Vdc or 120–240 Vac

Rated Voltage: 125–250 Vdc
 110–240 Vac
 Operational Voltage Range: 85–300 Vdc
 85–264 Vac
 Rated Frequency: 50/60 Hz
 Operational Frequency Range: 30–120 Hz
 Vdc Input Ripple: 15% per IEC 60255-26:2013
 Interruption: 46 ms @ 125 Vdc, 250 ms @ 250 Vdc
 per IEC 60255-26:2013
 Burden: <35 W, <90 VA

Control Outputs

Note: IEEE C37.90-2005 and IEC 60255-27:2013

Update Rate: 1/8 cycle
 Make (Short Duration Contact Current): 30 Adc
 1,000 operations at 250 Vdc
 2,000 operations at 125 Vdc
 Limiting Making Capacity: 1000 W at 250 Vdc (L/R = 40 ms)
 Mechanical Endurance: 10,000 operations

Standard

Rated Voltage: 24–250 Vdc
 110–240 Vrms
 Operational Voltage Range: 0–300 Vdc
 0–264 Vrms
 Operating Time: Pickup ≤6 ms (resistive load)
 Dropout ≤6 ms (resistive load)
 Short-Time Thermal Withstand: 50 A for 1 s
 Continuous Contact Current: 6 A at 70°C
 4 A at 85°C
 Contact Protection: MOV protection across open contacts
 264 Vrms continuous voltage
 300 Vdc continuous voltage
 Limiting Breaking Capacity/Electrical Endurance: 10,000 operations
 10 operations in 4 seconds, followed by 2 minutes idle

Rated Voltage	Resistive Break	Inductive Break L/R = 40 ms (DC) PF = 0.4 (AC)
24 Vdc	0.75 Adc	0.75 Adc
48 Vdc	0.63 Adc	0.63 Adc
125 Vdc	0.30 Adc	0.30 Adc
250 Vdc	0.20 Adc	0.20 Adc
110 Vrms	0.30 Arms	0.30 Arms
240 Vrms	0.20 Arms	0.20 Arms

Hybrid (High-Current Interrupting)

Rated Voltage: 24–250 Vdc
 Operational Voltage Range: 0–300 Vdc
 Operating Time: Pickup ≤6 ms (resistive load)
 Dropout ≤6 ms (resistive load)
 Short Time Thermal Withstand: 50 Adc for 1 s
 Continuous Contact Current: 6 Adc at 70°C
 4 Adc at 85°C
 Contact Protection: MOV protection across open contacts
 300 Vdc continuous voltage
 Limiting Breaking Capacity/Electrical Endurance: 10,000 operations
 4 operations in 1 second,
 followed by 2 minutes idle

Rated Voltage	Resistive Break	Inductive Break
24 Vdc	10 Adc	10 Adc (L/R = 40ms)
48 Vdc	10 Adc	10 Adc (L/R = 40 ms)
125 Vdc	10 Adc	10 Adc (L/R = 40 ms)
250 Vdc	10 Adc	10 Adc (L/R = 20 ms)

Note: Do not use hybrid control outputs to switch ac control signals. These outputs are polarity-dependent.

Fast Hybrid (High-Speed High-Current Interrupting)

Rated Voltage: 24–250 Vdc
 Operational Voltage Range: 0–300 Vdc
 Operating Time: Pickup ≤10 μs (resistive load)
 Dropout ≤8 ms (resistive load)
 Short Time Thermal Withstand: 50 Adc for 1 s
 Continuous Contact Current: 6 Adc at 70°C
 4 Adc at 85°C

Contact Protection:	MOV protection across open contacts 300 Vdc continuous voltage
Limiting Breaking Capacity/Electrical Endurance:	10,000 operations 4 operations in 1 second, followed by 2 minutes idle

Rated Voltage	Resistive Break	Inductive Break
24 Vdc	10 Adc	10 Adc (L/R = 40 ms)
48 Vdc	10 Adc	10 Adc (L/R = 40 ms)
125 Vdc	10 Adc	10 Adc (L/R = 40 ms)
250 Vdc	10 Adc	10 Adc (L/R = 20 ms)

Note: Do not use hybrid control outputs to switch ac control signals. These outputs are polarity-dependent.

Control Inputs

Optoisolated (Use With AC or DC Signals)

Main Board:	No I/O
INT2, INT7, INT8, and INTE Interface Boards:	8 inputs with no shared terminals
INT4, INTC, and INTD Interface Board:	6 inputs with no shared terminals 18 inputs with shared terminals (2 groups of 9 inputs with each group sharing one terminal)
Voltage Options:	24, 48, 110, 125, 220, 250 V
Current Draw:	<5 mA at nominal voltage <8 mA for 110 V option
Sampling Rate:	2 kHz

DC Thresholds

24 Vdc:	Pickup 19.2–30.0 Vdc; Dropout < 14.4 Vdc
48 Vdc:	Pickup 38.4–60.0 Vdc; Dropout < 28.8 Vdc
110 Vdc:	Pickup 88.0–132.0 Vdc; Dropout < 66.0 Vdc
125 Vdc:	Pickup 105–150.0 Vdc; Dropout < 75 Vdc
220 Vdc:	Pickup 176–264.0 Vdc; Dropout < 132 Vdc
250 Vdc:	Pickup 200–300.0 Vdc; Dropout < 150 Vdc

AC Thresholds (Ratings met only when recommended control input settings are used.)

24 Vac:	Pickup 16.4–30.0 Vac rms; Dropout < 10.1 Vac rms
48 Vac:	Pickup 32.8–60.0 Vac rms; Dropout < 20.3 Vac rms
110 Vac:	Pickup 75.1–132.0 Vac rms; Dropout < 46.6 Vac rms
125 Vac:	Pickup 89.6–150.0 Vac rms; Dropout < 53.0 Vac rms
220 Vac:	Pickup 150.3–264.0 Vac rms; Dropout < 93.2 Vac rms
250 Vac:	Pickup 170.6–264.0 Vac rms; Dropout < 106 Vac rms

Communications Ports

EIA-232:	1 Front and 3 Rear
Serial Data Speed:	300–57600 bps

Communications Card Slot for Optional Ethernet Card

Ordering Options:	10/100BASE-T
Connector Type:	RJ45
Ordering Option:	100BASE-FX Fiber-Optic
Connector Type:	LC
Fiber Type:	Multimode
Wavelength:	1300 nm
Source:	LED
Min. TX Power:	–19 dBm
Max. TX Power:	–14 dBm
RX Sensitivity:	–32 dBm
Sys. Gain:	13 dB

Differential Communications Ports

Fiber Optics–ST Connector

1550 nm Single-Mode	
Tx Power:	–18 dBm
Rx Min. Sensitivity:	–58 dBm
Rx Max. Sensitivity:	0 dBm
System Gain:	40 dB
Distance Limitations:	120 km
1300 nm Multimode or Single-Mode	
Tx Power:	–18 dBm
Rx Min. Sensitivity:	–58 dBm
Rx Max. Sensitivity:	0 dBm
System Gain:	40 dB
Distance Limitations:	x km
where:	x = 30 for multimode x = 80 for single mode

1300 nm Single-Mode, C37.94

Tx Power:	–24 dBm
Rx Min. Sensitivity:	–37.8 dBm
Rx Max. Sensitivity:	0 dBm
System Gain:	13.8 dB
Distance Limitations:	15 km

850 nm Multimode, C37.94

Tx Mean Power:	50 μ m: –23 dBm to –11 dBm 62.5 μ m: –19 dBm to –11 dBm
Extinction Ratio:	<10%
Rx Sensitivity:	50 μ m: –32 dBm to –11 dBm 62.5 μ m: –32 dBm to –11 dBm
System Gain:	50 μ m: >9 dB; 62.5 μ m: >13 dB
Distance Limitations:	2 km

Electrical

EIA-422:	64 kbps synchronous
CCITT G.703:	64 kbps synchronous, codirectional

Time Inputs

IRIG-B Input–Serial Port 1

Input:	Demodulated IRIG-B
Rated Voltage:	5 Vdc
Operational Voltage Range:	0–8 Vdc
Logic High Threshold:	≥ 2.8 Vdc

Logic Low Threshold:	≤0.8 Vdc
Input Impedance:	2.5 kΩ
IRIG-B Input–BNC Connector	
Input:	Demodulated IRIG-B
Rated Voltage:	5 Vdc
Operational Voltage Range:	0–8 Vdc
Logic High Threshold:	≥2.8 Vdc
Logic Low Threshold:	≤0.8 Vdc
Input Impedance:	>1 kΩ
Rated Insulation Voltage:	150 Vdc
PTP–Ethernet Port 5A, 5B	
Input:	IEEE 1588 PTPv2
Profiles:	Default, C37.238-2011 (Power Profile), IEC/IEEE 61850-9-3-2016 (Power Utility Automation Profile)
Synchronization Accuracy:	±100 ns @ 1-second synchronization intervals when communicating directly with master clock

Operating Temperature

–40° to +85°C (–40° to +185°F)

Control Outputs: As many as 30 outputs can be energized
at or below 40°C ambient.

Note: LCD contrast impaired for temperatures below –20° and above +70°C

Humidity

5% to 95% without condensation

Overvoltage Category

Category II

Insulation Class

I

Pollution Degree

2

Weight (Maximum)

4U Rack Unit:	10.3 kg (22.8 lb)
5U Rack Unit:	12.0 kg (26.4 lb)
6U Rack Unit:	13.5 kg (29.8 lb)
7U Rack Unit:	15.3 kg (33.7 lb)

Terminal Connections

Rear Screw-Terminal Tightening Torque, #8 Ring Lug

Minimum:	1.0 Nm (9 in-lb)
Maximum:	2.0 Nm (18 in-lb)

User terminals and stranded copper wire should have a minimum
temperature rating of 105°C. Ring terminals are recommended.

Wire Sizes and Insulation

Wire sizes for grounding (earthing), current, voltage, and contact
connections are dictated by the terminal blocks and expected load
currents. You can use the following table as a guide in selecting wire
sizes. The grounding conductor should be as short as possible and sized
equal to or greater than any other conductor connected to the device,
unless otherwise required by local or national wiring regulations.

Connection Type	Min. Wire Size	Max. Wire Size
Grounding (Earthing) Connection	14 AWG (2.5 mm ²)	N/A
Current Connection	16 AWG (1.5 mm ²)	10 AWG (5.3 mm ²)
Potential (Voltage) Connection	18 AWG (0.8 mm ²)	14 AWG (2.5 mm ²)
Contact I/O	18 AWG (0.8 mm ²)	10 AWG (5.3 mm ²)
Other Connection	18 AWG (0.8 mm ²)	10 AWG (5.3 mm ²)

Type Tests

Installation Requirements

Overvoltage Category:	3
Pollution Degree:	2

Safety

Product Standards	IEC 60255-27:2013 IEEE C37.90-2005 21 CFR 1040.10
Dielectric Strength:	IEC 60255-27:2013, Section 10.6.4.3 2.5 kVac, 50/60 Hz for 1 min: analog inputs, contact outputs, digital inputs 3.6 kVdc for 1 min: power supply, battery monitors 2.2 kVdc for 1 min: IRIG-B 1.1 kVdc for 1 min: Ethernet
Impulse Withstand:	IEC 60255-27:2013, Section 10.6.4.2 IEEE C37.90-2005 Common Mode: ±1.0 kV: Ethernet ±2.5 kV: IRIG-B ±5.0 kV: all other ports Differential Mode: 0 kV: analog inputs, Ethernet, IRIG-B, digital inputs ±5.0 kV: standard contact outputs, power supply battery monitors +5.0 kV: hybrid contact outputs
Insulation Resistance:	IEC 60255-27:2013, Section 10.6.4.4 >100 MΩ @ 500 Vdc
Protective Bonding:	IEC 60255-27:2013, Section 10.6.4.5.2 <0.1 Ω @ 12 Vdc, 30 A for 1 min
Ingress Protection:	IEC 60529:2001 + CRGD:2003 IEC 60255-27:2013 IP30 for front and rear panel IP10 for rear terminals with installation of ring lug IP40 for front panel with installation of serial port cover
Max Temperature of Parts and Materials:	IEC 60255-27:2013, Section 7.3
Flammability of Insulating Materials:	IEC 60255-27:2013, Section 7.6 Compliant
Laser Safety:	IEC 60825-1:2007 21 CFR 1040.10 Class 1

Electromagnetic (EMC) Immunity

Product Standards:	IEC 60255-26:2013 IEC 60255-27:2013 IEEE C37.90-2005	Power Supply Immunity:	IEC 61000-4-11:2004 IEC 61000-4-17:1999/A1:2001/A2:2008 IEC 61000-4-29:2000 AC Dips & Interruptions Ripple on DC Power Input DC Dips & Interruptions Gradual Shutdown/Startup (DC only) Discharge of Capacitors Slow Ramp Down/Up Reverse Polarity (DC only)
Surge Withstand Capability (SWC):	IEC 61000-4-18:2006 + A:2010 IEEE C37.90.1-2012 Slow Damped Oscillatory, Common and Differential Mode: ±1.0 kV ±2.5 kV Fast Transient, Common and Differential Mode: ±4.0 kV	Damped Oscillatory Magnetic Field:	IEC 61000-4-10:2016 Level 5: 100 A/m
Electrostatic Discharge (ESD):	IEC 61000-4-2:2008 IEEE C37.90.3-2001 Contact: ±8 kV Air Discharge: ±15 kV	EMC Compatibility	
Radiated RF Immunity:	IEEE C37.90.2-2004 IEC 61000-4-3:2006 + A1:2007 + A2:2010 20 V/m (>35 V/m, 80% AM, 1 kHz) Sweep: 80 MHz to 1 GHz Spot: 80, 160, 450, 900 MHz 10 V/m (>15 V/m, 80% AM, 1 kHz) Sweep: 80 MHz to 1 GHz Sweep: 1.4 GHz to 2.7 GHz Spot: 80, 160, 380, 450, 900, 1850, 2150 MHz	Product Standards:	IEC 60255-26:2013
Electrical Fast Transient Burst (EFTB):	IEC 61000-4-4:2012 Zone A: ±2 kV: communication ports ±4 kV: all other ports	Emissions:	IEC 60255-26:2013, Section 7.1 Class A 47 CFR Part 15B Class A Canada ICES-001 (A) / NMB-001 (A)
Surge Immunity:	IEC 61000-4-5:2005 Zone A: ±2 kV _{L-L} ±4 kV _{L-E} ±4 kV: communication ports (Ethernet) Note: Cables connected to EIA-422, G.703, EIA-232, and IRIG-B communications ports shall be less than 10 m in length for Zone A compliance. Zone B: ±1 kV _{L-L} : 24–48 Vdc power supply ±2 kV _{L-E} : 24–48 Vdc power supply ±2 kV: communication ports (except Ethernet) Note: Cables connected to EIA-232 communications ports shall be less than 10 m in length for Zone B compliance.	Environmental	
Conducted Immunity:	IEC 61000-4-6:2013 20 V/m; (>35 V/m, 80% AM, 1 kHz) Sweep: 150 kHz–80 MHz Spot: 27, 68 MHz	Product Standards:	IEC 60255-27:2013
Power Frequency Immunity (DC Inputs):	IEC 61000-4-16:2015 Zone A: Differential: 150 V _{RMS} Common Mode: 300 V _{RMS}	Cold, Operational:	IEC 60068-2-1:2007 Test Ad: 16 hours at –40°C
Power Frequency Magnetic Field:	IEC 61000-4-8:2009 Level 5: 100 A/m; ≥60 seconds; 50/60 Hz 1000 A/m 1 to 3 seconds; 50/60 Hz Note: 50G1P ≥0.05 (ESS = N, 1, 2) 50G1P ≥0.1 (ESS = 3, 4)	Cold, Storage:	IEC 60068-2-1:2007 Test Ad: 16 hours at –40°C
		Dry Heat, Operational:	IEC 60068-2-2:2007 Test Bd: 16 hours at +85°C
		Dry Heat, Storage:	IEC 60068-2-2:2007 Test Bd: 16 hours at +85°C
		Damp Heat, Cyclic:	IEC 60068-2-30:2005 Test Db: +25°C to +55°C, 6 cycles (12 + 12-hour cycle), 95% RH
		Damp Heat, Steady State:	IEC 60068-2-78:2013 Severity: 93% RH, +40°C, 10 days
		Cyclic Temperature:	IEC 60068-2-14:2009 Test Nb: –40 °C to +80°C, 5 cycles
		Vibration Resistance:	IEC 60255-21-1:1988 Class 2 Endurance, Class 2 Response
		Shock Resistance:	IEC 60255-21-2:1988 Class 1 Shock Withstand, Class 1 Bump Withstand, Class 2 Shock Response
		Seismic:	IEC 60255-21-3:1993 Class 2 Quake Response
		Reporting Functions	
		Traveling-Wave Fault Location	
		Application:	Two terminal lines with high-accuracy time sources
		Method:	Double-ended traveling wave
		Sampling Rate:	1.5625 MHz
		Device Accuracy:	±25 meters for a step change in current applied simultaneously to both relays
		Application Accuracy:	300 m typical
		Output Format:	Binary COMTRADE
		High-Resolution Data	
		Rate:	8000 samples/second 4000 samples/second 2000 samples/second 1000 samples/second
		Output Format:	Binary COMTRADE
		Note:	Per IEEE Std C37.111-1999 and C37.111-2013, Common Format for Transient Data Exchange (COMTRADE) for Power Systems.

Event Reports

Resolution: 8- or 4-samples/cycle

Event Summary

Storage: 100 summaries

Breaker History

Storage: 128 histories

Sequential Events Recorder

Storage: 1000 entries

Trigger Elements: 250 relay elements

Resolution: 0.5 ms for contact inputs
1/8 cycle for all elements

Processing Specifications**AC Voltage and Current Inputs**

8000 samples per second, 3 dB low-pass analog filter cut-off frequency of 3000 Hz

Digital Filtering

Full-cycle cosine and half-cycle Fourier filters after low-pass analog and digital filtering

Protection and Control Processing

8 times per power system cycle

Synchrophasors

Maximum data rate in messages per second

IEEE C37.118 Protocol: 60 (nominal 60 Hz system)
50 (nominal 50 Hz system)

SEL Fast Message Protocol: 20 (nominal 60 Hz system)
10 (nominal 50 Hz system)

Control Points

64 remote bits
64 local control bits
32 latch bits in protection logic
32 latch bits in automation logic

Relay Element Pickup Ranges and Accuracies**Line Current Differential (87L) Elements****87L Enable Levels**

Unrestraint Differential Element Setting Range: OFF, 3.0 to 15 per unit, 0.1 pu steps

Phase Setting Range (Normal): OFF, 0.10 to 2 per unit, 0.01 pu steps

Phase Setting Range (Secure): OFF, 0.10 to 2 per unit, 0.01 pu steps

Negative-Sequence

Setting Range (Normal): OFF, 0.10 to 2.00 per unit, 0.01 pu steps

Setting Range (Secure): OFF, 0.10 to 2.00 per unit, 0.01 pu steps

Zero-Sequence

Setting Range (Normal): OFF, 0.10 to 2.00 per unit, 0.01 pu steps

Setting Range (Secure): OFF, 0.10 to 2.00 per unit, 0.01 pu steps

Accuracy: $\pm 3\% \pm 0.01 I_{NOM}$

Restraint Characteristics

Outer Radius (Phase, Negative-Sequence, Zero-Sequence)

Radius Range (Normal): 1.2 to 8 in steps of 0.01 (unitless)

Radius Range (Secure): 1.2 to 8 in steps of 0.01 (unitless)

Angle Range (Normal): 90–270° in steps of 1°

Angle Range (Secure): 90–270° in steps of 1°

Accuracy: $\pm 5\%$ of radius setting
 $\pm 3^\circ$ of angle setting

Line-Charging Current Compensation

Positive-Sequence Line

Susceptance Setting Range: 0.00 to 250 mS, 0.01 mS steps

Zero-Sequence Line

Susceptance Setting Range: 0.00 to 100 mS, 0.01 mS steps

In-Line Transformer

MVA Setting Range: 1 to 5,000, 1 MVA steps

Vector Group Compensation: 360°, 30° steps

Line-to-Line Setting Range: 1.00 to 1,000 kV, 0.01 kV steps

Harmonic Restraint: 2nd, 4th Setting Range: OFF, 5 to 100%, 1% steps

Harmonic Blocking: 2nd, 4th and 5th Setting Range: OFF, 5 to 100%, 1% steps

Mho Phase Distance Elements**Zones 1–5 Impedance Reach**

Setting Range

5 A Model: OFF, 0.05 to 64 Ω secondary, 0.01 Ω steps

1 A Model: OFF, 0.25 to 320 Ω secondary, 0.01 Ω steps

Sensitivity

5 A Model: 0.5 A_{p-p} secondary

1 A Model: 0.1 A_{p-p} secondary
(Minimum sensitivity is controlled by the pickup of the supervising phase-to-phase overcurrent elements for each zone.)

Accuracy (Steady State): $\pm 3\%$ of setting at line angle for SIR (source-to-line impedance ratio) < 30
 $\pm 5\%$ of setting at line angle for $30 \leq SIR \leq 60$

Zone 1 Transient

Overreach: $< 5\%$ of setting plus steady-state accuracy

Operating Time:

See *Figure 9*.

Quadrilateral Phase Distance Elements**Zones 1–5 Impedance Reach**

Quadrilateral Reactance Reach

5 A Model: OFF, 0.05 to 64 Ω secondary, 0.01 Ω steps

1 A Model: OFF, 0.25 to 320 Ω secondary, 0.01 Ω steps

Quadrilateral Resistance Reach

Zones 1, 2, and 3

5 A Model: OFF, 0.05 to 50 Ω secondary, 0.01 Ω steps

Zones 1, 2, and 3

1 A Model: OFF, 0.25 to 250 Ω secondary, 0.01 Ω steps

Zones 4 and 5

5 A Model: OFF, 0.05 to 150 Ω secondary, 0.01 Ω steps

Zones 4 and 5

1 A Model: OFF, 0.25 to 750 Ω secondary, 0.01 Ω steps

Sensitivity

5 A Model: 0.5 A secondary

1 A Model: 0.1 A secondary

Accuracy (Steady State): $\pm 3\%$ of setting at line angle for SIR < 30
 $\pm 5\%$ of setting at line angle for $30 \leq SIR \leq 60$

Transient Overreach:

$< 5\%$ of setting *plus* steady-state accuracy

Operating Time:

See *Figure 9*.

Mho Ground Distance Elements

Zones 1–5 Impedance Reach

Mho Element Reach

5 A Model:	OFF, 0.05 to 64 Ω secondary, 0.01 Ω steps
1 A Model:	OFF, 0.25 to 320 Ω secondary, 0.01 Ω steps

Sensitivity

5 A Model:	0.5 A secondary
1 A Model:	0.1 A secondary (Minimum sensitivity is controlled by the pickup of the supervising phase and residual overcurrent elements for each zone.)

Accuracy (Steady State):	$\pm 3\%$ of setting at line angle for $SIR < 30$ $\pm 5\%$ of setting at line angle for $30 \leq SIR \leq 60$
--------------------------	---

Zone 1 Transient Overreach:	$< 5\%$ of setting <i>plus</i> steady-state accuracy
-----------------------------	--

Operating Time:	See <i>Figure 9</i> .
-----------------	-----------------------

Quadrilateral Ground Distance Elements

Zones 1–5 Impedance Reach

Quadrilateral Reactance Reach

5 A Model:	OFF, 0.05 to 64 Ω secondary, 0.01 Ω steps
1 A Model:	OFF, 0.25 to 320 Ω secondary, 0.01 Ω steps

Quadrilateral Resistance Reach

Zones 1, 2, and 3	
5 A Model:	OFF, 0.05 to 50 Ω secondary, 0.01 Ω steps
Zones 1, 2, and 3	
1 A Model:	OFF, 0.25 to 250 Ω secondary, 0.01 Ω steps
Zones 4 and 5	
5 A Model:	OFF, 0.05 to 150 Ω secondary, 0.01 Ω steps
Zones 4 and 5	
1 A Model:	OFF, 0.25 to 750 Ω secondary, 0.01 Ω steps

Sensitivity

5 A Model:	0.5 A secondary
1 A Model:	0.1 A secondary (Minimum sensitivity is controlled by the pickup of the supervising phase and residual overcurrent elements for each zone.)

Accuracy (Steady State):	$\pm 3\%$ of setting at line angle for $SIR < 30$ $\pm 5\%$ of setting at line angle for $30 \leq SIR \leq 60$
--------------------------	---

Transient Overreach:	$< 5\%$ of setting <i>plus</i> steady-state accuracy
----------------------	--

Operating Time:	See <i>Figure 9</i> .
-----------------	-----------------------

Instantaneous/Definite-Time Overcurrent Elements

Phase, Residual Ground, and Negative-Sequence

Pickup Range

5 A Model:	OFF, 0.25–100.00 A secondary, 0.01 A steps
1 A Model:	OFF, 0.05–20.00 A secondary, 0.01 A steps

Accuracy (Steady State)

5 A Model:	± 0.05 A plus $\pm 3\%$ of setting
1 A Model:	± 0.01 A plus $\pm 3\%$ of setting

Transient Overreach:	$< 5\%$ of pickup
----------------------	-------------------

Time Delay:	0.00–16000.00 cycles, 0.125 cycle steps
-------------	---

Timer Accuracy:	± 0.125 cycle plus $\pm 0.1\%$ of setting
-----------------	---

Maximum Operating Time:	1.5 cycles
-------------------------	------------

High-Speed Directional Overcurrent Elements

Ground and Phase

Pickup Range

5 A Model:	OFF, 0.25–100 A secondary, 0.01 A steps
1 A Model:	OFF, 0.05–20 A secondary, 0.01 A steps

Transient Overreach:	5% of pickup
----------------------	--------------

Maximum Operating Time:	0.75 cycles
-------------------------	-------------

Time-Overcurrent Elements

Pickup Range

5 A Model:	0.25–16.00 A secondary, 0.01 A steps
1 A Model:	0.05–3.20 A secondary, 0.01 A steps

Accuracy (Steady State)

5 A Model:	± 0.05 A plus $\pm 3\%$ of setting
1 A Model:	± 0.01 A plus $\pm 3\%$ of setting

Time Dial Range

U.S.:	0.50–15.00, 0.01 steps
-------	------------------------

IEC:	0.05–1.00, 0.01 steps
------	-----------------------

Curve Timing Accuracy:	± 1.50 cycles plus $\pm 4\%$ of curve time (for current between 2 and 30 multiples of pickup)
------------------------	--

Reset:	1 power cycle or Electromechanical Reset Emulation time
--------	---

Ground-Directional Elements

Neg.-Seq. Directional Impedance Threshold (Z2F, Z2R)

5 A Model:	–64 to 64 Ω
------------	--------------------

1 A Model:	–320 to 320 Ω
------------	----------------------

Zero-Seq. Directional Impedance Threshold (Z0F, Z0R)

5 A Model:	–64 to 64 Ω
------------	--------------------

1 A Model:	–320 to 320 Ω
------------	----------------------

Supervisory Overcurrent Pickup 50FP, 50RP

5 A Model:	0.25 to 5.00 A 3I0 secondary 0.25 to 5.00 A 3I2 secondary
------------	--

1 A Model:	0.05 to 1.00 A 3I0 secondary 0.05 to 1.00 A 3I2 secondary
------------	--

Directional Power Elements

Pickup Range

5 A Model:	–20000.00 to 20000 VA, 0.01 VA steps
------------	--------------------------------------

1 A Model:	–4000.00 to 4000 VA, 0.01 VA steps
------------	------------------------------------

Accuracy (Steady State):	± 5 VA plus $\pm 3\%$ of setting at nominal frequency and voltage
--------------------------	---

Time-Delay:	0.00–16000.00 cycles, 0.25 cycle steps
-------------	--

Timer Accuracy:	± 0.25 cycle plus $\pm 0.1\%$ of setting
-----------------	--

Under- and Overvoltage Elements

Pickup Ranges:	Phase elements: 1–200 V secondary, 1 V steps
----------------	---

Phase-to-Phase Elements:	1.0–300.0 V secondary, 0.1 V steps
--------------------------	------------------------------------

Accuracy (Steady State):	± 1 V plus $\pm 5\%$ of setting
--------------------------	-------------------------------------

Transient Overreach:	$< 5\%$ of pickup
----------------------	-------------------

Under- and Overfrequency Elements

Pickup Range:	40.01–69.99 Hz, 0.01 Hz steps
---------------	-------------------------------

Accuracy, Steady State Plus Transient:	± 0.005 Hz for frequencies between 40.00 and 70.00 Hz
--	---

Maximum Pickup/Dropout Time:	3.0 cycles
Time-Delay Range:	0.04–400.0 s, 0.01 s increments
Time-Delay Accuracy:	$\pm 0.1\% \pm 0.0042$ s
Pickup Range, Undervoltage Blocking:	20.00–200.00 V_{LN} (Wye)
Pickup Accuracy, Undervoltage Blocking:	$\pm 2\% \pm 2$ V

Optional RTD Elements (Models Compatible With SEL-2600A RTD Module)

12 RTD Inputs via SEL-2600 RTD Module and SEL-2800 Fiber-Optic Transceiver

Monitor Ambient or Other Temperatures

PT 100, NI 100, NI 120, and CU 10 RTD-Types Supported, Field Selectable

As long as 500 m Fiber-Optic Cable to SEL-2600 RTD Module

Breaker-Failure Instantaneous Overcurrent

Setting Range	
5 A Model:	0.50–50.0 A, 0.01 A steps
1 A Model:	0.10–10.0 A, 0.01 A steps
Accuracy	
5 A Model:	± 0.05 A plus $\pm 3\%$ of setting
1 A Model:	± 0.01 A plus $\pm 3\%$ of setting
Transient Overreach:	<5% of setting
Maximum Pickup Time:	1.5 cycles
Maximum Reset Time:	1 cycle
Timers Setting Range:	0–6000 cycles, 0.125 cycle steps (All but BFIDOn, BFISPN) 0–1000 cycles, 0.125 cycle steps (BFIDOn, BFISPN)
Time Delay Accuracy:	0.125 cycle plus $\pm 0.1\%$ of setting

Broken Conductor Detection Element

Sensitivity (Minimum Line-Charging Current Required for Broken Conductor Detection):	
5 A Model:	50 mA, secondary
1 A Model:	10 mA, secondary
Maximum Operating Time (After the Conductor Breaks and Series Arc Extinguishes):	
	6 cycles
Time Delay for Zone 2:	OFF, 0–600 cycles, 1 cycle increment
Timer Accuracy:	± 1 cycle

Synchronism-Check Elements

Slip Frequency Pickup Range:	0.005–0.500 Hz, 0.001 Hz steps
Slip Frequency Pickup Accuracy:	± 0.0025 Hz plus $\pm 2\%$ of setting
Close Angle Range:	3–80°, 1° steps
Close Angle Accuracy:	$\pm 3^\circ$

Load-Encroachment Detection

Setting Range	
5 A Model:	0.05–64 Ω secondary, 0.01 Ω steps
1 A Model:	0.25–320 Ω secondary, 0.01 Ω steps
Forward Load Angle:	–90° to +90°
Reverse Load Angle:	+90° to +270°

Accuracy	
Impedance Measurement:	$\pm 3\%$
Angle Measurement:	$\pm 2^\circ$

Out-of-Step Elements

Blinders (R1) Parallel to the Line Angle	
5 A Model:	0.05 to 140 Ω secondary –0.05 to –140 Ω secondary
1 A Model:	0.25 to 700 Ω secondary –0.25 to –700 Ω secondary
Blinders (X1) Perpendicular to the Line Angle	
5 A Model:	0.05 to 96 Ω secondary –0.05 to –96 Ω secondary
1 A Model:	0.25 to 480 Ω secondary –0.25 to –480 Ω secondary
Accuracy (Steady State)	$\pm 3\%$ of setting for SIR (source to line impedance ratio) <30 $\pm 5\%$ of setting for 30 \leq SIR \leq 60
Transient Overreach:	<5% of setting

Positive-Sequence Overcurrent Supervision

Setting Range	
5 A Model:	1.0–100.0 A, 0.01 A steps
1 A Model:	0.2–20.0 A, 0.01 A steps
Accuracy	
5 A Model:	$\pm 3\%$ of setting plus ± 0.05 A
1 A Model:	$\pm 3\%$ of setting plus ± 0.01 A
Transient Overreach:	<5% of setting

Bay Control

Breakers:	2 (control), 3rd indication
Disconnects (Isolators):	10 (maximum)
Timers Setting Range:	1–99999 cycles, 1-cycle steps
Time-Delay Accuracy:	$\pm 0.1\%$ of setting, ± 0.125 cycle

Timer Specifications

Breaker Failure:	0–6000 cycles, 0.125 cycle steps (All but BFIDOn, BFISPN) 0–1000 cycles, 0.125 cycle steps (BFIDOn, BFISPN)
Communications-Assisted Tripping Schemes:	0.000–16000 cycles, 0.125 cycle steps
Out-of-Step Timers	
OSBD, OSTD:	0.500–8000 cycles, 0.125 cycle steps
UBD:	0.500–120 cycles, 0.125 cycle steps
Pole-Open Timer:	0.000–60 cycles, 0.125 cycle steps
Recloser:	1–99999 cycles, 1 cycle steps
Switch-Onto-Fault	
CLOEND, 52AEND:	OFF, 0.000–16000 cycles, 0.125 cycle steps
SOTFD:	0.50–16000 cycles, 0.125 cycle steps
Synchronism-Check Timers	
TCLSBK1, TCLSBK2:	1.00–30.00 cycles, 0.25 cycle steps
Zone Time Delay:	0.000–16000 cycles, 0.125 cycle steps

Station DC Battery System Monitor Specifications

Rated Voltage:	24–250 Vdc
Operational Voltage Range:	0–300 Vdc

Sampling Rate:	DC1: 2 kHz DC2: 1 kHz
Processing Rate:	1/8 cycle
Operating Time:	<1.5 cycles (all elements except ac ripple) <1.5 seconds (ac ripple element)
Setting Range	
DC Settings:	1 Vdc steps (OFF, 15–300 Vdc)
AC Ripple Setting:	1 Vac steps (1–300 Vac)
Pickup Accuracy:	$\pm 3\% \pm 2$ Vdc (all elements except ac ripple) $\pm 10\% \pm 2$ Vac (ac ripple element)

Metering Accuracy

All metering accuracy is at 20°C, and nominal frequency unless otherwise noted.

Currents

Phase Current Magnitude

5 A Model:	$\pm 0.2\%$ plus ± 4 mA (2.5–15 A s)
1 A Model:	$\pm 0.2\%$ plus ± 0.8 mA (0.5–3 A s)

Phase Current Angle

All Models:	$\pm 0.2^\circ$ in the current range $0.5 \cdot I_{NOM}$ to $3.0 \cdot I_{NOM}$
-------------	---

Sequence Currents Magnitude

5 A Model:	$\pm 0.3\%$ plus ± 4 mA (2.5–15 A s)
1 A Model:	$\pm 0.3\%$ plus ± 0.8 mA (0.5–3 A s)

Sequence Current Angle

All Models:	$\pm 0.3^\circ$ in the current range $0.5 \cdot I_{NOM}$ to $3.0 \cdot I_{NOM}$
-------------	---

Voltages

Phase and Phase-to-Phase Voltage Magnitude:	$\pm 0.1\%$ (33.5–200 V_{L-N})
---	-----------------------------------

Phase and Phase-to-Phase Angle:	$\pm 0.5^\circ$ (33.5–200 V_{L-N})
---------------------------------	---------------------------------------

Sequence Voltage Magnitude:	$\pm 0.15\%$ (33.5–200 V_{L-N})
-----------------------------	------------------------------------

Sequence Voltage Angle:	$\pm 0.5^\circ$ (33.5–200 V_{L-N})
-------------------------	---------------------------------------

Frequency (Input 40–65 Hz)

Accuracy:	± 0.01 Hz
-----------	---------------

Power and Energy

Real Power, P (MW), Three Phase

At $0.1 \cdot I_{NOM}$	
Power Factor Unity:	$\pm 0.4\%$
Power Factor 0.5 Lag, 0.5 Lead:	$\pm 0.7\%$
At $1.0 \cdot I_{NOM}$	
Power Factor Unity:	$\pm 0.4\%$
Power Factor 0.5 Lag, 0.5 Lead:	$\pm 0.4\%$

Reactive Power, Q (MVAR), Three Phase

At $0.1 \cdot I_{NOM}$	
Power Factor 0.5 Lag, 0.5 Lead:	$\pm 0.5\%$
At $1.0 \cdot I_{NOM}$	
Power Factor 0.5 Lag, 0.5 Lead:	$\pm 0.4\%$

Energy (MWh), Three Phase

At $0.1 \cdot I_{NOM}$	
Power Factor Unity:	$\pm 0.5\%$
Power Factor 0.5 Lag, 0.5 Lead:	$\pm 0.7\%$
At $1.0 \cdot I_{NOM}$	
Power Factor Unity:	$\pm 0.4\%$
Power Factor 0.5 Lag, 0.5 Lead:	$\pm 0.4\%$

Synchrophasors

Synchrophasor Measurement:	IEC/IEEE 60255-118-1:2018 (IEEE Std. C37.118.1:2011, 2014a)
----------------------------	---

Synchrophasor Data Transfer:	IEEE Std. C37.118.2:2011
------------------------------	--------------------------

Number of Synchrophasor Data Streams:	5
---------------------------------------	---

Number of Synchrophasors for Each Stream:	15 phase synchrophasors (6 voltage and 9 currents) 5 positive-sequence synchrophasors (2 voltage and 3 currents)
---	---

Number of User Analogs for Each Stream:	16 (any analog quantity)
---	--------------------------

Number of User Digitals for Each Stream:	64 (any Relay Word bit)
--	-------------------------

Synchrophasor Data Rate:	As many as 60 messages per second (60 Hz) As many as 50 messages per second (50 Hz)
--------------------------	--

Synchrophasor Accuracy:	Class P/M
-------------------------	-----------

Synchrophasor Data Recording:	Records as much as 120 s IEEE C37.232-2011 File Naming Convention
-------------------------------	--

Technical Support

We appreciate your interest in SEL products and services. If you have questions or comments, please contact us at:

Schweitzer Engineering Laboratories, Inc.
2350 NE Hopkins Court
Pullman, WA 99163-5603 U.S.A.
Tel: +1.509.338.3838
Fax: +1.509.332.7990
Internet: selinc.com/support
Email: info@selinc.com

Notes

© 2011-2024 by Schweitzer Engineering Laboratories, Inc.

Content subject to change without notice.

Unless otherwise agreed in writing, all SEL product sales are subject to SEL's terms and conditions located here: <https://selinc.com/company/termsandconditions/>.

SCHWEITZER ENGINEERING LABORATORIES, INC.

2350 NE Hopkins Court • Pullman, WA 99163-5603 U.S.A.

Tel: +1.509.332.1890 • Fax: +1.509.332.7990

selinc.com • info@selinc.com



* P D S 4 1 1 L - 0 1 *