



# FN 17

## Diesel Generator



YANGDONG

**FULL**  
ALTERNATOR

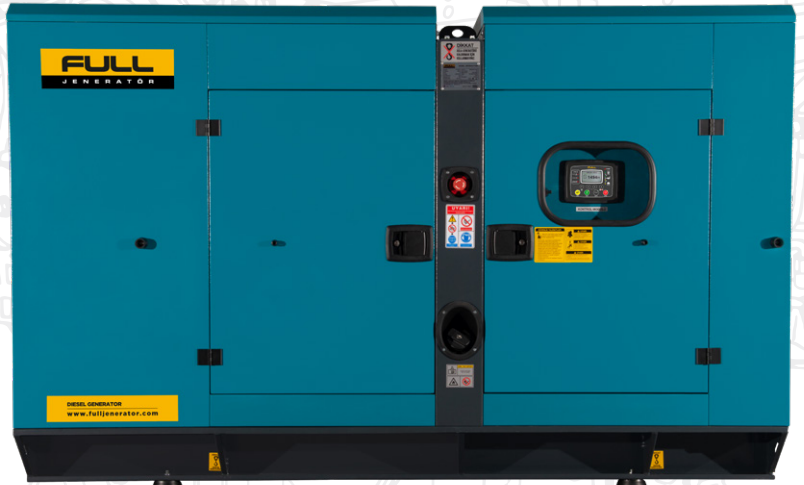

### GENERAL SPECIFICATIONS

Stand By Power	kVA	17
	kW	13.6
Prime Power	kVA	15.4
	kW	12.3
Frequency	Hz	50
Cooling System	Water Cooling	

- 1) Standby power: The max power available during a variable electrical power sequence, under the stated operating conditions, for which a generating set is capable of delivering in the event of a utility power outage. Overloading isn't permissible.
- 2) Prime Power: The maximum power which a generating set is capable of delivering continuously whilst supplying a variable electrical load. Average load should be 70%. The generator can be overloaded 10% for 1 hour per 12 hrs.

### DIMENSIONS & WEIGHT

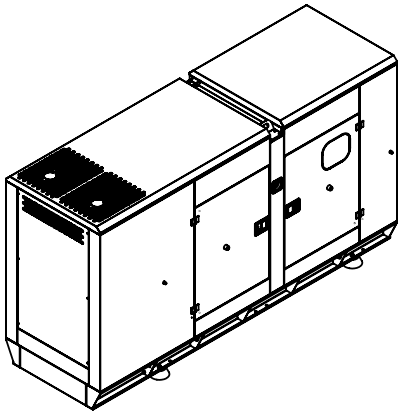

#### WITH CANOPY

Length L (mm)	Width W (mm)	Height H (mm)	Weight (Kg)	Fuel Tank Capacity
1400	750	1100	540	115

#### OPEN TYPE

Length L (mm)	Width W (mm)	Height H (mm)	Weight (Kg)	Fuel Tank Capacity
1400	750	1300	450	115

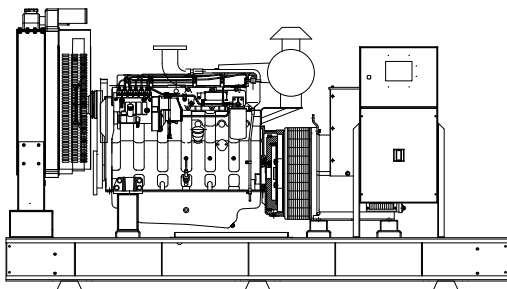

### ENGINE

Engine	YANGDONG		
Engine Model			YD480D
Number of Cylinders			4 Inline
Injection System			Direct
Compression Ratio			18
Bore		mm	80
Stroke		mm	90
Displacement		lt	1.81
Air Intake			Natural Aspiration
Speed (RPM)		rpm	1500
Oil Capacity		lt	6.7
Standby Power		kW / hp	16 / 20
Prime Power		kW / hp	14 / 18.9
Fuel Type			Euro Diesel
Governor System			Mechanical
Cooling System			Water Cooling
Coolant Capacity		lt	7.6
Fuel Consumption (lt / h)	Full Load		4.1
	%75 Load		3.1
	%50 Load		2

### ALTERNATOR

Alternator Model			FLYS164D
Frequency		Hz	50
Power		kVA	17.7
Voltage		V	400
Nb of Phases			3
Voltage Regulation			±1%
Insulation Class			H
Protection Standard			IP23
Power Factor		Cos	0.8

### TECHNICAL SPECIFICATIONS

#### ENGINE

- YANGDONG heavy duty diesel engine
- 12V starter and charge alternator
- Replaceable air, fuel and oil filters
- Mechanical or electronic governor control
- Tropical type radiator
- Flexible fuel hose
- Oil drain valve and extension hose
- Industrial type silencer and steel compensator
- Maintenance-free starter battery
- Water jacket heater
- 1500 rpm engine speed

#### ALTERNATOR

- IP23 Protection Standard
- H Insulation Class
- 50 Hz Frequency
- 4 pole brushless synchronous type alternator
- Automatic Voltage Regulator (AVR)
- 400/230V AC Output Voltage - 1500 rpm

#### SOUND PROOF CANOPY AND CHASSIS

- Convenient design for easy lifting and carrying
- High standard sound proof canopy design
- Modular design with easily removable nuts - bolts
- Lockable doors
- Transparent window for watching Control Panel
- Electrostatic powder painted, providing protection against harsh weather conditions
- Emergency STOP button
- Fuel tank inside the chassis
- Anti-vibration wedges (engine - chassis and chassis - ground)

#### OPTIONAL

- Thermal magnetic CB (for automatic models)
- Super Silent Canopy
- Mobile Generator Sets
- Automatic fuel filling system
- Synchronization panel
- 3 Pole and 4 Pole ATS (Automatic Transfer Switch)
- Fuel Heater, Oil Heater
- External fuel tank and automatic fuel filling system
- Fuel - water separator filter
- Remote monitoring and control system



**CONTROL PANEL**

**D 300**  
Web based  
Next Generation  
Controller



**SPECIFICATIONS**

- Diesel and gas genset support
- 400Hz operation support
- 400 event logs, full snapshot
- All parameters front panel editable
- 3 level configuration password
- 128x64 graphical LCD display
- Downloadable languages
- Waveform display of V & I
- Harmonic analysis of V & I
- 16Amp MCB & GCB outputs
- 8 configurable digital inputs
- 6 configurable digital outputs
- 3 configurable analog inputs
- Both CANBUS-J1939 & MPU
- 3 configurable service alarms
- Multiple automatic exerciser
- Weekly operation schedule
- Dual mutual standby with equal aging of gensets
- Manual "speed fine adjust" on selected ECUs
- Automatic fuel pump control
- Disable protections feature
- Excess power protection
- Reverse power protection
- Overload IDMT protection
- Load shedding, dummy load
- Multiple load management
- Current unbalance protection
- Voltage unbalance protection
- Fuel filling & fuel theft alarms
- Battery back-up real time clock
- Idle speed control
- Battery charge run enabled
- Combat mode support
- Multiple nominal conditions
- Contactor & MCB drive
- 4 quadrant genset power counters
- Mains power counters
- Fuel filling counter
- Fuel consumption counter
- Modem diagnostics display
- Configurable through USB, RS-232 and GPRS
- Free configuration program
- Allows SMS controls
- Ready for central monitoring
- Mobile genset support
- Automatic GSM geo-location
- GPS connectivity (RS232)
- Easy USB firmware upgrade
- IP65 rating with optional gasket

**MEASUREMENTS**

- Mains & genset PN/PP voltages
- Mains & genset frequency
- Mains & genset phase currents
- Mains & genset neutral currents
- Mains & genset, phase & total, kW, kVA, kVAR, pf
- Engine speed
- Battery voltage

**FUNCTIONALITIES**

- AMF unit
- ATS unit
- Remote start controller
- Manual start controller
- Engine controller
- Remote display panel

**COMMUNICATION**

- USB Device
- RS-232 (2400-57600baud)
- J1939-CANBUS
- Geo-locating through GSM
- GPS support (RS-232)
- Internet Central Monitoring
- SMS message sending
- E-mail sending
- Free PC software: Rainbow Plus
- Modbus RTU
- Modbus TCP/IP