



Service Manual

GREE ELECTRIC APPLIANCES, INC. OF ZHUHAI



Table of Contents

Part I : Technical Information	1
1. Summary	1
2. Specifications	3
2.1 Specification Sheet.....	3
2.2 Operation Characteristic Curve.....	11
2.2 Capacity Curve in Different Outdoor Temperature.....	11
2.3 Cooling and Heating Data Sheet in Rated Frequency.....	11
2.5 Noise Curve.....	12
3. Outline Dimension Diagram	13
3.1 Indoor Unit.....	13
3.2 Outdoor Unit.....	14
4. Refrigerant System Diagram	16
5. Electrical Part	17
5.1 Wiring Diagram.....	17
5.2 PCB Printed Diagram.....	20
6. Function and Control	23
6.1 Remote Controller Introduction.....	23
6.2 GREE+ App Operation Manual.....	27
6.3 Ewpe Smart App Operation Manual.....	28
6.4 Brief Description of Modes and Functions.....	29

Part I : Technical Information

1. Summary

Indoor Unit:

GWH18AAD-K6DNA1B/I
GWH18AAD-K6DNA1A/I
GWH24AAD-K6DNA1A/I

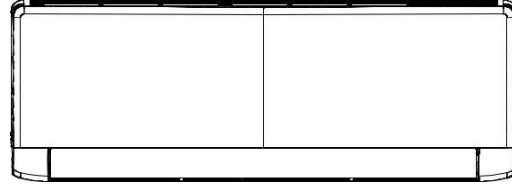

GWH24AAD-K6DNA5A/I
GWH18AAD-K6DNA5A/I
GWH18AAD-K6DNA5B/I

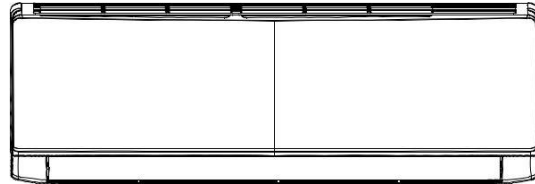

GWH18AAD-K6DNA4A/I
GWH18AAD-K6DNA4B/I
GWH24AAE-K6DNA4C/I
GWH24AAD-K6DNA4A/I

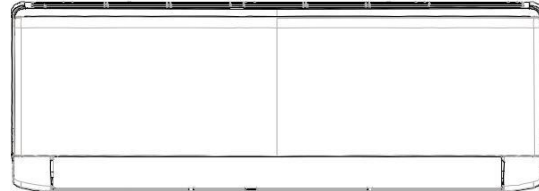

GWH18AAD-K6DNA2A/I
GWH24AAD-K6DNA2A/I

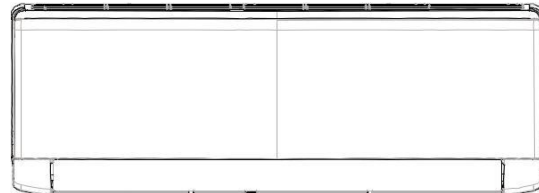

Outdoor Unit:

GWH18AAD-K6DNA1B/O

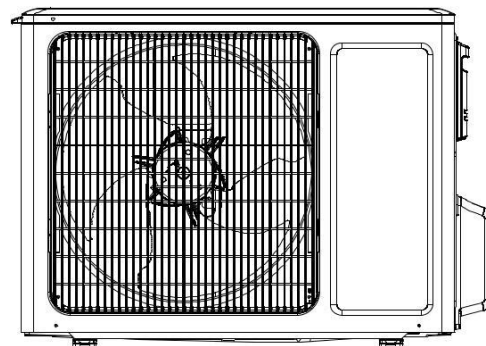

GWH18AAD-K6DNA1A/O

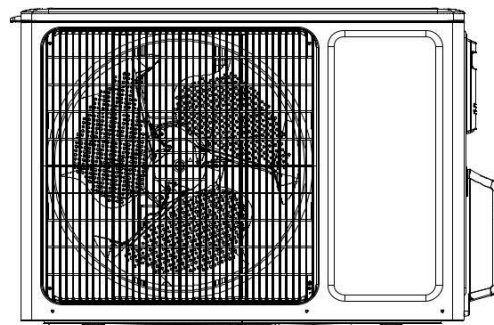

GWH24AAD-K6DNA1A/O

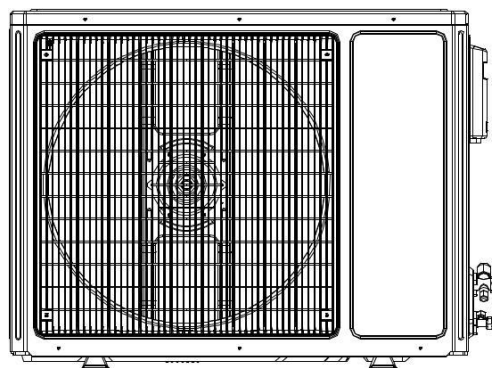

GWH24QE-K6DNA1C/O

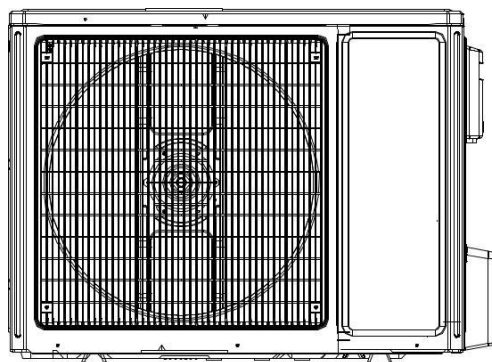

Remote Controller:

YAW1F5(WiFi)



Model List:

No	Model	Product code	Indoor model	Indoor product code	Outdoor model	Outdoor product code	Remote Controller
1	GWH18AAD-K6DNA1A	CB476000200	GWH18AAD-K6DNA1A/I	CB476N00200	GWH18AAD-K6DNA1A/O	CB476W00200	YAW1F5 (WiFi)
2	GWH18AAD-K6DNA1A	CB476000201	GWH18AAD-K6DNA1A/I	CB476N00201			
3	GWH18AAD-K6DNA5A	CB488000700	GWH18AAD-K6DNA5A/I	CB488N00700			
4	GWH18AAD-K6DNA2A	CB477001300	GWH18AAD-K6DNA2A/I	CB477N01300			
5	GWH18AAD-K6DNA4A	CB479000600	GWH18AAD-K6DNA4A/I	CB479N00600	GWH24AAD-K6DNA1A/O	CB476W00100	
6	GWH24AAD-K6DNA1A	CB476000100	GWH24AAD-K6DNA1A/I	CB476N00100			
7	GWH24AAD-K6DNA1A	CB476000101	GWH24AAD-K6DNA1A/I	CB476N00101			
8	GWH24AAD-K6DNA5A	CB488000500	GWH24AAD-K6DNA5A/I	CB488N00500			
9	GWH24AAD-K6DNA4A	CB479000900	GWH24AAD-K6DNA4A/I	CB479N00900			
10	GWH24AAD-K6DNA4A	CB479000901	GWH24AAD-K6DNA4A/I	CB479N00901			
11	GWH24AAD-K6DNA5A	CB488000501	GWH24AAD-K6DNA5A/I	CB488N00501			
12	GWH24AAD-K6DNA2A	CB477001400	GWH24AAD-K6DNA2A/I	CB477N01400			
13	GWH18AAD-K6DNA1B	CB476000600	GWH18AAD-K6DNA1B/I	CB476N00600	GWH18AAD-K6DNA1B/O	CB476W00600	
14	GWH18AAD-K6DNA5B	CB488000600	GWH18AAD-K6DNA5B/I	CB488N00600			
15	GWH18AAD-K6DNA4B	CB479001300	GWH18AAD-K6DNA4B/I	CB479N01300			
16	GWH18AAD-K6DNA4B	CB479001301	GWH18AAD-K6DNA4B/I	CB479N013001			
17	GWH18AAD-K6DNA5B	CB488000601	GWH18AAD-K6DNA5B/I	CB488N00601			
18	GWH24AAE-K6DNA4C	CB479000700	GWH24AAE-K6DNA4C/I	CB479N00700			

2. Specifications

2.1 Specification Sheet

Model			1.GWH18AAD-K6DNA1A 2.GWH18AAD-K6DNA5A 3.GWH18AAD-K6DNA4A 4.GWH18AAD-K6DNA2A	
Product Code			1.CB476000200/CB476000201 2. CB488000700 3.CB479000600 4.CB477001300	
Power Supply	Rated Voltage	V~	220-240	
	Rated Frequency	Hz	50	
	Phases		1	
Power Supply Mode			Outdoor	
Cooling Capacity		W	5130	
Heating Capacity		W	5280	
Cooling Power Input		W	1600	
Heating Power Input		W	1450	
Cooling Power Current		A	7.0	
Heating Power Current		A	6.3	
Rated Input		W	2300	
Rated Current		A	10.8	
Rated Heating Current		A	12	
Air Flow Volume(SH/H/M/L/SL)		m ³ /h	850/720/610/520/-	
Dehumidifying Volume		L/h	1.8	
EER		W/W	3.21	
COP		W/W	3.64	
SEER		W/W	6.1	
HSPF		W/W	/	
Application Area		m ²	23-34	
Indoor Unit	Model of Indoor Unit		1.GWH18AAD-K6DNA1A/I 2.GWH18AAD-K6DNA5A/I 3. GWH18AAD-K6DNA4A/I 4.GWH18AAD-K6DNA2A/I	
	Product Code of Indoor Unit		1.CB476N00200/CB476N00201 2.CB488N00700 3.CB479N00600 4. CB477N01300	
	Fan Type		Cross-flow	
	Diameter Length(DXL)		mm	Φ106X706
	Fan Motor Cooling Speed(SH/H/M/L/SL)		r/min	1230/1130/1030/800/-
	Fan Motor Heating Speed(SH/H/M/L/SL)		r/min	1350/1200/1050/900/-
	Output of Fan Motor		W	35
	Fan Motor RLA		A	0.35
	Fan Motor Capacitor		μF	2.5
	Input of Heater		W	/
	Evaporator Form			Aluminum Fin-copper Tube
	Pipe Diameter		mm	Φ7
	Row-fin Gap		mm	2-1.4
	Coil Length (LXDXW)		mm	715X25.4X304.8
	Swing Motor Model			MP35CP
	Output of Swing Motor		W	2.5
	Fuse		A	3.15
	Sound Pressure Level (SH/H/M/L/SL)		dB (A)	48/44/39/34/-
	Sound Power Level (SH/H/M/L/SL)		dB (A)	58/54/49/44/-
	Dimension (WXHDX)		mm	970X300X225
Dimension of Carton Box (LXWXH)		mm	1017X366X285	
Dimension of Package (LXWXH)		mm	1020X369X295	
Net Weight		kg	13.5	
Gross Weight		kg	16.5	

Outdoor Unit	Model of Outdoor Unit		GWH18AAD-K6DNA1A/O	
	Product Code of Outdoor Unit		CB476W00200	
	Compressor Manufacturer/Trademark		ZHUHAI LANDA COMPRESSOR CO.,LTD	
	Compressor Model		QXF-B141ZF030A	
	Compressor Oil		68DA	
	Compressor Type		Rotary	
	L.R.A.	A		25
	Compressor RLA	A		6.5
	Compressor Power Input	W		1410
	Overload Protector			1NT11L-6233/KSD115°C/HPC 115/95
	Throttling Method			Electron expansion valve
	Operation Temp	°C		16~30
	Ambient Temp (Cooling)	°C		-15~43
	Ambient Temp (Heating)	°C		-15~24
	Condenser Form			Aluminum Fin-copper Tube
	Pipe Diameter	mm		Φ7.94
	Rows-fin Gap	mm		2-1.4
	Coil Length (LXD _{XW})	mm		742X38.1X550
	Fan Motor Speed	rpm		780
	Output of Fan Motor	W		40
	Fan Motor RLA	A		0.62
	Fan Motor Capacitor	μF		/
	Air Flow Volume of Outdoor Unit	m ³ /h		2400
	Fan Type			Axial-flow
	Fan Diameter	mm		Φ445
	Defrosting Method			/
	Climate Type			T1
	Isolation			I
	Moisture Protection			IPX4
	Permissible Excessive Operating Pressure for the Discharge Side	MPa		4.3
	Permissible Excessive Operating Pressure for the Suction Side	MPa		2.5
Sound Pressure Level (H/M/L)	dB (A)		56/-/-	
Sound Power Level (H/M/L)	dB (A)		66/-/-	
Dimension (WXHXD)	mm		899X596X378	
Dimension of Carton Box (LXWXH)	mm		945X417X630	
Dimension of Package (LXWXH)	mm		948X420X645	
Net Weight	kg		39	
Gross Weight	kg		42	
Refrigerant			R32	
Refrigerant Charge	kg		0.9	
Connection Pipe	Length	m	5	
	Gas Additional Charge	g/m	16	
	Outer Diameter Liquid Pipe	mm	Φ6	
	Outer Diameter Gas Pipe	mm	Φ12	
	Max Distance Height	m	10	
	Max Distance Length	m	25	
Note: The connection pipe applies metric diameter.				

The above data is subject to change without notice; please refer to the nameplate of the unit.

Model			1.GWH24AAD-K6DNA1A 2.GWH24AAD-K6DNA5A 3.GWH24AAD-K6DNA4A 4.GWH24AAD-K6DNA5A 5.GWH24AAD-K6DNA2A	
Product Code			1.CB476000100/CB476000101 2.CB488000500 3.CB479000900/CB479000901 4.CB488000501 5.CB477001400	
Power Supply	Rated Voltage	V~	220-240	
	Rated Frequency	Hz	50	
	Phases		1	
Power Supply Mode			Outdoor	
Cooling Capacity		W	6155	
Heating Capacity		W	6448	
Cooling Power Input		W	1760	
Heating Power Input		W	1860	
Cooling Power Current		A	7.7	
Heating Power Current		A	8.1	
Rated Input		W	2600	
Rated Current		A	10.9	
Rated Heating Current		A	11.3	
Air Flow Volume(SH/H/M/L/SL)		m ³ /h	850/720/610/520/-	
Dehumidifying Volume		L/h	1.8	
EER		W/W	3.5	
COP		W/W	3.47	
SEER		W/W	6.1	
HSPF		W/W	/	
Application Area		m ²	23-24	
Indoor Unit	Model of Indoor Unit		1.GWH24AAD-K6DNA1A/I 2.GWH24AAD-K6DNA5A/I 3.GWH24AAD-K6DNA4A/I 4.GWH24AAD-K6DNA5A/I 5.GWH24AAD-K6DNA2A/I	
	Product Code of Indoor Unit		1.CB476N00100/CB476N00101 2.CB488N00500 3.CB479N00900/CB479N00901 4.CB488N00501 5.CB477N01400	
	Fan Type		Cross-flow	
	Diameter Length(DXL)		mm	Φ106X706
	Fan Motor Cooling Speed(SH/H/M/L/SL)		r/min	1230/1130/1030/800/-
	Fan Motor Heating Speed(SH/H/M/L/SL)		r/min	1350/1200/1050/900/-
	Output of Fan Motor		W	35
	Fan Motor RLA		A	0.35
	Fan Motor Capacitor		μF	2.5
	Input of Heater		W	/
	Evaporator Form			Aluminum Fin-copper Tube
	Pipe Diameter		mm	Φ7
	Row-fin Gap		mm	2-1.4
	Coil Length (LXDXW)		mm	715X25.4X304.8
	Swing Motor Model			MP35CP
	Output of Swing Motor		W	2.5
	Fuse		A	3.15
	Sound Pressure Level (SH/H/M/L/SL)		dB (A)	48/44/40/34/-
	Sound Power Level (SH/H/M/L/SL)		dB (A)	58/54/50/44/-
	Dimension (WXHXD)		mm	970X300X225
	Dimension of Carton Box (LXWXH)		mm	1017X366X285
Dimension of Package (LXWXH)		mm	1020X369X295	
Net Weight		kg	13.5	
Gross Weight		kg	16.5	

Outdoor Unit	Model of Outdoor Unit		GWH24AAD-K6DNA1A/O	
	Product Code of Outdoor Unit		CB476W00100	
	Compressor Manufacturer/Trademark		ZHUHAI LANDA COMPRESSOR CO.,LTD	
	Compressor Model		QXF-B141ZF030A	
	Compressor Oil		68DA	
	Compressor Type		Rotary	
	L.R.A.	A		25
	Compressor RLA	A		6.5
	Compressor Power Input	W		1410
	Overload Protector			1NT11L-6233/KSD115°C/HPC 115/95
	Throttling Method			Electron expansion valve
	Operation Temp	°C		16~30
	Ambient Temp (Cooling)	°C		-15~43
	Ambient Temp (Heating)	°C		-15~24
	Condenser Form			Aluminum Fin-copper Tube
	Pipe Diameter	mm		Φ7
	Rows-fin Gap	mm		2-1.4
	Coil Length (LXD _{XW})	mm		935X38.1X660
	Fan Motor Speed	rpm		780
	Output of Fan Motor	W		60
	Fan Motor RLA	A		0.49
	Fan Motor Capacitor	μF		/
	Air Flow Volume of Outdoor Unit	m ³ /h		3200
	Fan Type			Axial-flow
	Fan Diameter	mm		Φ520
	Defrosting Method			/
	Climate Type			T1
	Isolation			I
	Moisture Protection			IPX4
	Permissible Excessive Operating Pressure for the Discharge Side	MPa		4.3
	Permissible Excessive Operating Pressure for the Suction Side	MPa		2.5
	Sound Pressure Level (H/M/L)	dB (A)		57/-/-
Sound Power Level (H/M/L)	dB (A)		67/-/-	
Dimension (WXHXD)	mm		955X700X396	
Dimension of Carton Box (LXWXH)	mm		1026X455X735	
Dimension of Package (LXWXH)	mm		1029X458X750	
Net Weight	kg		49	
Gross Weight	kg		50.5	
Refrigerant			R32	
Refrigerant Charge	kg		1.3	
Connection Pipe	Length	m	5	
	Gas Additional Charge	g/m	40	
	Outer Diameter Liquid Pipe	mm	Φ6	
	Outer Diameter Gas Pipe	mm	Φ16	
	Max Distance Height	m	10	
	Max Distance Length	m	25	
Note: The connection pipe applies metric diameter.				

The above data is subject to change without notice; please refer to the nameplate of the unit.

Model			1.GWH18AAD-K6DNA1B 2.GWH18AAD-K6DNA5B 3.GWH18AAD-K6DNA4B	
Product Code			1.CB476000600 2.CB488000600/CB488000601 3.CB479001300/CB479001301	
Power Supply	Rated Voltage	V~	220-240	
	Rated Frequency	Hz	50	
	Phases		1	
Power Supply Mode			Outdoor	
Cooling Capacity		W	4600	
Heating Capacity		W	5200	
Cooling Power Input		W	1430	
Heating Power Input		W	1400	
Cooling Power Current		A	6.3	
Heating Power Current		A	6.2	
Rated Input		W	1700	
Rated Current		A	8	
Rated Heating Current		A	7.5	
Air Flow Volume(SH/H/M/L/SL)		m ³ /h	850/720/610/520/-	
Dehumidifying Volume		L/h	1.8	
EER		W/W	3.22	
COP		W/W	3.71	
SEER		W/W	6.1	
HSPF		W/W	/	
Application Area		m ²	21-31	
Indoor Unit	Model of Indoor Unit		1.GWH18AAD-K6DNA1B/I 2.GWH18AAD-K6DNA5B/I 3.GWH18AAD-K6DNA4B/I	
	Product Code of Indoor Unit		1.CB476N00600 2.CB488N00600/CB488N00601 3.CB479N01300/CB479N01301	
	Fan Type		Cross-flow	
	Diameter Length(DXL)		mm	Φ106X706
	Fan Motor Cooling Speed(SH/H/M/L/SL)		r/min	1230/1130/1030/800/-
	Fan Motor Heating Speed(SH/H/M/L/SL)		r/min	1350/1200/1050/900/-
	Output of Fan Motor		W	/
	Fan Motor RLA		A	0.35
	Fan Motor Capacitor		μF	2.5
	Input of Heater		W	/
	Evaporator Form			Aluminum Fin-copper Tube
	Pipe Diameter		mm	Φ7
	Row-fin Gap		mm	2-1.4
	Coil Length (LXDXW)		mm	715X25.4X304.8
	Swing Motor Model			MP35CP
	Output of Swing Motor		W	2.5
	Fuse		A	3.15
	Sound Pressure Level (SH/H/M/L/SL)		dB (A)	49/45/41/36/-
	Sound Power Level (SH/H/M/L/SL)		dB (A)	58/55/51/46/-
	Dimension (WXHXD)		mm	970X300X225
Dimension of Carton Box (LXWXH)		mm	1017X366X285	
Dimension of Package (LXWXH)		mm	1020X369X295	
Net Weight		kg	13.5	
Gross Weight		kg	16.5	

Outdoor Unit	Model of Outdoor Unit		GWH18AAD-K6DNA1B/O	
	Product Code of Outdoor Unit		CB476W00600	
	Compressor Manufacturer/Trademark		ZHUHAI LANDA COMPRESSOR CO., LTD	
	Compressor Model		QXF-B096zE190A	
	Compressor Oil		FW68DA	
	Compressor Type		Rotary	
	L.R.A.	A		20
	Compressor RLA	A		4.21
	Compressor Power Input	W		943
	Overload Protector			/
	Throttling Method			Capillary
	Operation Temp	°C		16~30
	Ambient Temp (Cooling)	°C		-15~43
	Ambient Temp (Heating)	°C		-15~24
	Condenser Form			Aluminum Fin-copper Tube
	Pipe Diameter	mm		Φ7
	Rows-fin Gap	mm		2-1.4
	Coil Length (LXDXW)	mm		742X38.1X550
	Fan Motor Speed	rpm		900
	Output of Fan Motor	W		30
	Fan Motor RLA	A		0.4
	Fan Motor Capacitor	μF		/
	Air Flow Volume of Outdoor Unit	m ³ /h		2200
	Fan Type			Axial-flow
	Fan Diameter	mm		Φ438
	Defrosting Method			Automatic Defrosting
	Climate Type			T1
	Isolation			I
	Moisture Protection			IPX4
	Permissible Excessive Operating Pressure for the Discharge Side	MPa		4.3
	Permissible Excessive Operating Pressure for the Suction Side	MPa		2.5
	Sound Pressure Level (H/M/L)	dB (A)		54/-/-
Sound Power Level (H/M/L)	dB (A)		64/-/-	
Dimension (WXHXD)	mm		848X596X320	
Dimension of Carton Box (LXWXH)	mm		878X360X630	
Dimension of Package (LXWXH)	mm		881X363X645	
Net Weight	kg		34	
Gross Weight	kg		37	
Refrigerant			R32	
Refrigerant Charge	kg		0.77	
Connection Pipe	Length	m	5	
	Gas Additional Charge	g/m	16	
	Outer Diameter Liquid Pipe	mm	Φ6	
	Outer Diameter Gas Pipe	mm	Φ9.52	
	Max Distance Height	m	10	
	Max Distance Length	m	20	
Note: The connection pipe applies metric diameter.				

The above data is subject to change without notice; please refer to the nameplate of the unit.

Parameter	Unit	Value
Model		GWH24AAE-K6DNA4C
Product Code		CB479000700
Power Supply	Rated Voltage	V~ 220-240
	Rated Frequency	Hz 50
	Phases	1
Power Supply Mode		Outdoor
Cooling Capacity	W	6450
Heating Capacity	W	6450
Cooling Power Input	W	1950
Heating Power Input	W	1735
Cooling Current Input	A	8.4
Heating Current Input	A	8.0
Rated Input	W	3100
Rated Current	A	13.04
Air Flow Volume(SH/H/M/L/SL)	m ³ /h	1250/1050/950/850/-
Dehumidifying Volume	L/h	2.0
EER	W/W	3.3
COP	W/W	3.71
SEER	W/W	6.30
SCOP(Average/Warmer/Colder)	W/W	4.0/5.1/3.3
Application Area	m ²	23-34
Indoor Unit	Indoor Unit Model	GWH24AAE-K6DNA4C/I
	Indoor Unit Product Code	CB479N00700
	Fan Type	Cross-flow
	Fan Diameter Length(DXL)	mm Φ 108X830
	Cooling Speed(SH/H/M/L/SL)	r/min 1250/1000/900/800/-
	Heating Speed(SH/H/M/L/SL)	r/min 1250/1000/900/850/-
	Fan Motor Power Output	W 35
	Fan Motor RLA	A 0.35
	Fan Motor Capacitor	μ F 3
	Evaporator Form	Aluminum Fin-copper Tube
	Evaporator Pipe Diameter	mm Φ 7
	Evaporator Row-fin Gap	mm 2-1.4
	Evaporator Coil Length (LXDXW)	mm 845X25.4X342.9
	Swing Motor Model	MP35CJ
	Swing Motor Power Output	W 2.5
	Fuse Current	A 3.15
	Sound Pressure Level(SH/H/M/L/SL)	dB (A) 49/44/41/39/-
	Sound Power Level(SH/H/M/L/SL)	dB (A) 63/59/56/53/-
	Dimension (WXHDXD)	mm 1078X325X246
	Dimension of Carton Box (LXWXH)	mm 1145X410X335
	Dimension of Package(LXWXH)	mm 1148X413X350
Net Weight	kg 16.5	
Gross Weight	kg 20	

Outdoor Unit	Outdoor Unit Model		GWH24QE-K6DNA1C/O	
	Outdoor Unit Product Code		CB419W12200	
	Compressor Manufacturer		ZHUHAI LANDA COMPRESSOR CO,LTD.	
	Compressor Model		QXFS-D23zX090A	
	Compressor Oil		FW68DA	
	Compressor Type		Rotary	
	Compressor LRA.	A		25
	Compressor RLA	A		11.50
	Compressor Power Input	W		2400
	Compressor Overload Protector			1NT11L-6233 or HPC115/95/ or KSD115°C
	Throttling Method			Electron expansion valve
	Set Temperature Range	°C		16~30
	Cooling Operation Ambient Temperature Range	°C		-15~43
	Heating Operation Ambient Temperature Range	°C		-15~24
	Condenser Form			Aluminum Fin-copper Tube
	Condenser Pipe Diameter	mm		Φ7
	Condenser Rows-fin Gap	mm		2-1.4
	Condenser Coil Length (LXDXW)	mm		935X38.1X660
	Fan Motor Speed	rpm		800
	Fan Motor Power Output	W		60
	Fan Motor RLA	A		0.58
	Fan Motor Capacitor	μF		/
	Outdoor Unit Air Flow Volume	m ³ /h		3200
	Fan Type			Axial-flow
	Fan Diameter	mm		Φ520
	Defrosting Method			Automatic Defrosting
	Climate Type			T1
	Isolation			I
	Moisture Protection			IPX4
	Permissible Excessive Operating Pressure for the Discharge Side	MPa		4.3
	Permissible Excessive Operating Pressure for the Suction Side	MPa		2.5
	Sound Pressure Level (H/M/L)	dB (A)		58/-/-
Sound Power Level (H/M/L)	dB (A)		68/-/-	
Dimension(WXHXD)	mm		963X700X396	
Dimension of Carton Box (LXWXH)	mm		1026X455X735	
Dimension of Package(LXWXH)	mm		1029X458X750	
Net Weight	kg		52.5	
Gross Weight	kg		57	
Refrigerant			R32	
Refrigerant Charge	kg		1.7	
Connection Pipe	Connection Pipe Length	m	5	
	Connection Pipe Gas Additional Charge	g/m	50	
	Outer Diameter Liquid Pipe	mm	Φ6	
	Outer Diameter Gas Pipe	mm	Φ16	
	Max Distance Height	m	10	
	Max Distance Length	m	25	
Note: The connection pipe applies metric diameter.				

The above data is subject to change without notice. Please refer to the nameplate of the unit.

2.2 Operation Characteristic Curve

Cooling

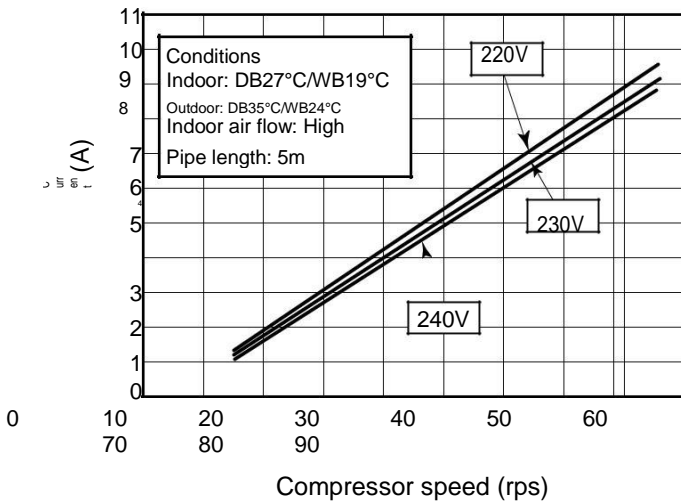

Heating

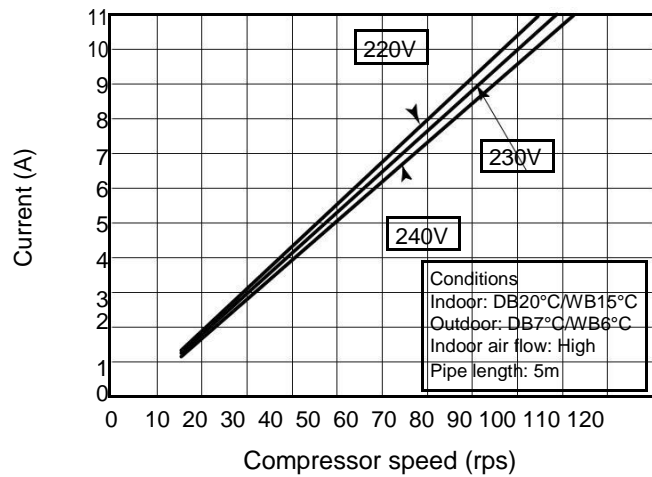

2.2 Capacity Curve in Different Outdoor Temperature

Cooling

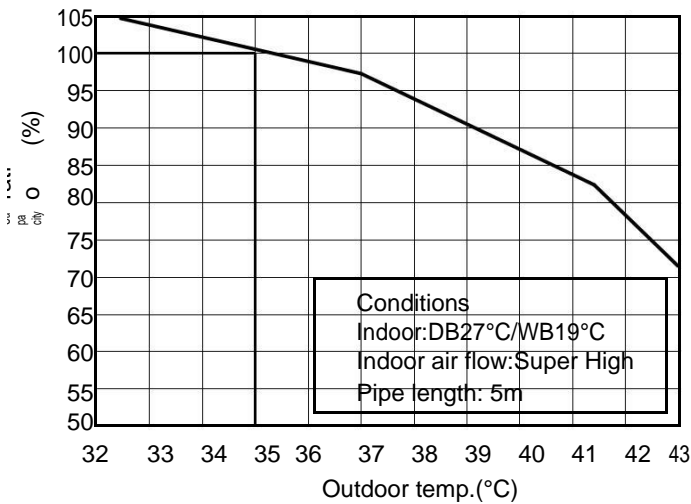

Heating

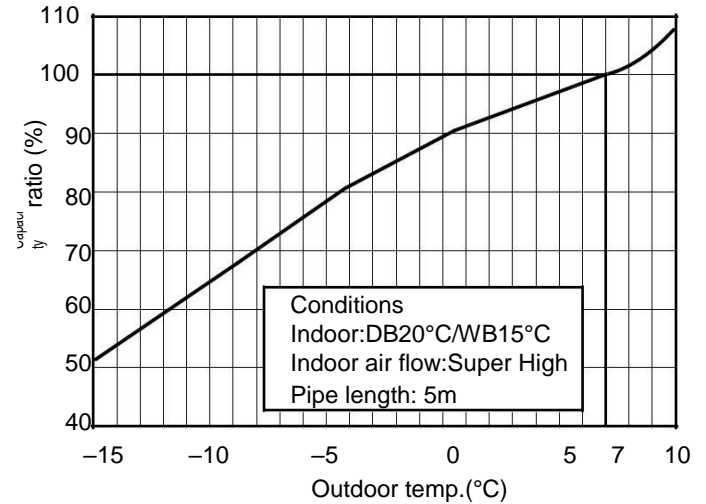

2.3 Cooling and Heating Data Sheet in Rated Frequency

Cooling

Rated cooling condition(°C) (DB/WB)		Model	Pressure of gas pipe connecting indoor and outdoor unit	Inlet and outlet pipe temperature of heat exchanger		Fan speed of indoor unit	Fan speed of outdoor unit
Indoor	Outdoor			T1 (°C)	T2 (°C)		
27/19	35/24	18/24K	P (MPa) 0.8~1.0	in:8~11 out:11~14	in:75~85 out:37~43	Super High	High

Heating

Rated heating condition(°C) (DB/WB)		Model	Pressure of gas pipe connecting indoor and outdoor unit	Inlet and outlet pipe temperature of heat exchanger		Fan speed of indoor unit	Fan speed of outdoor unit
Indoor	Outdoor			T1 (°C)	T2 (°C)		
20/-	7/6	18/24K	3.5~3.8	in:75~85 out:37~43	in:1~3 out:2~5	Super High	High

Instruction:

T1: Inlet and outlet pipe temperature of evaporator

T2: Inlet and outlet pipe temperature of condenser

P: Pressure at the side of big

valve Connection pipe length: 5m.

2.5 Noise Curve

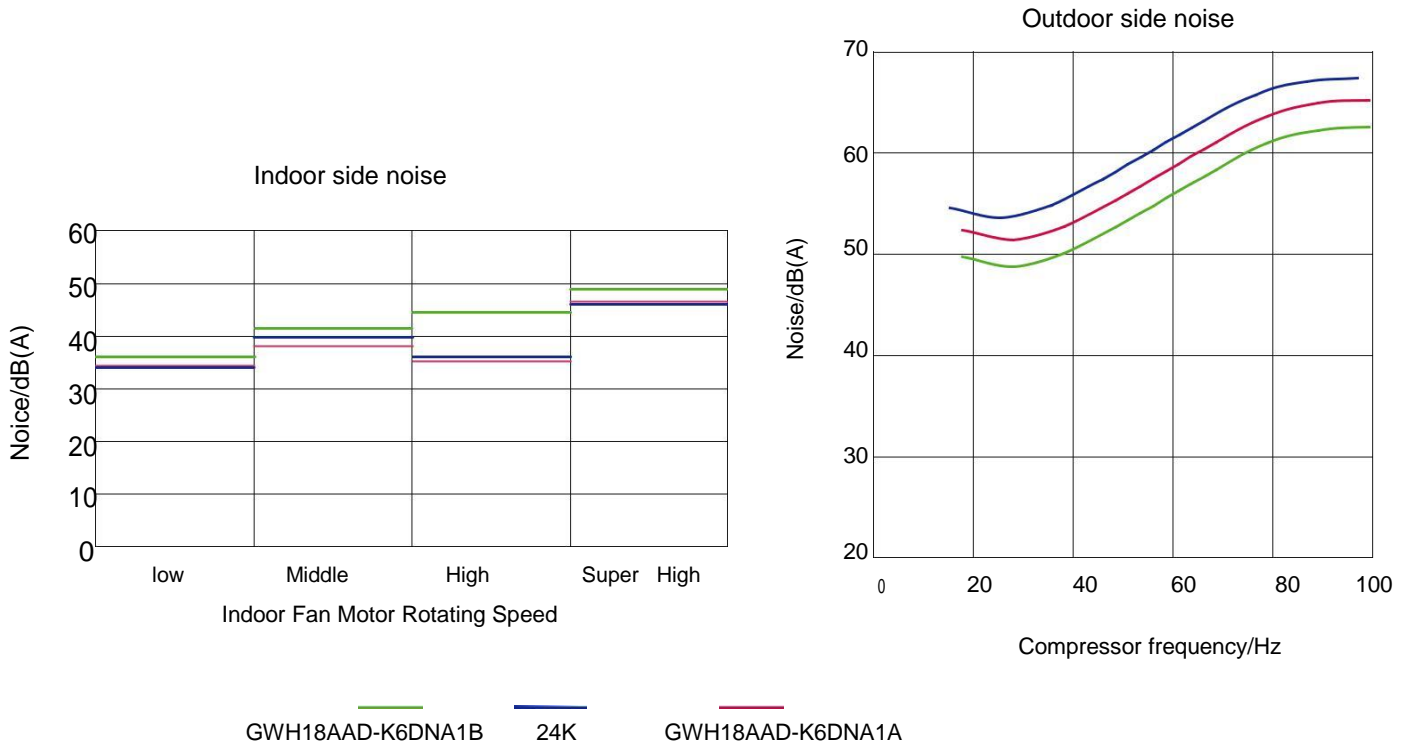

3. Outline Dimension Diagram

3.1 Indoor Unit

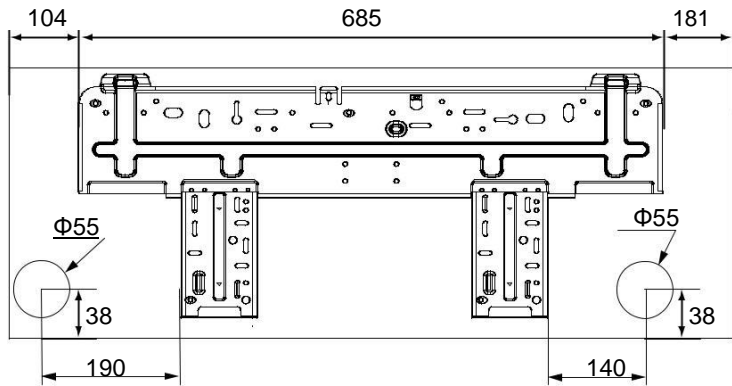
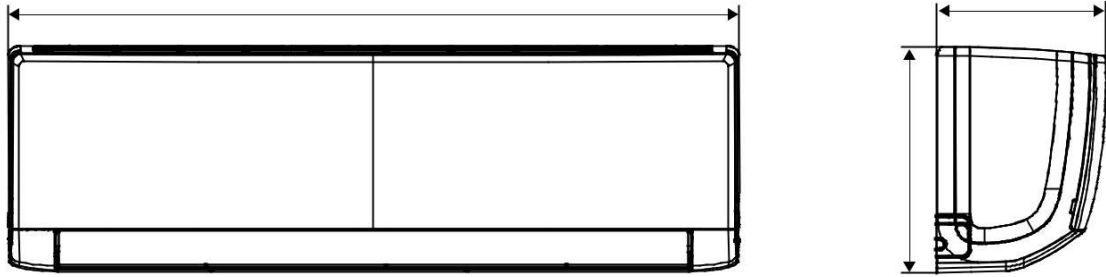

18/24AAD

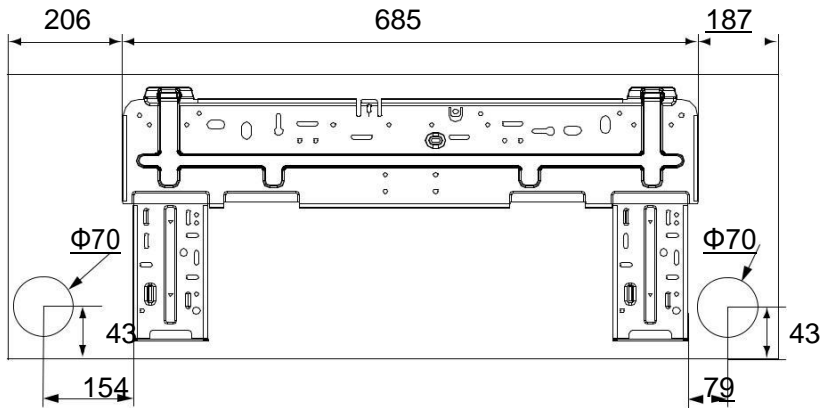

24AAE

Unit:mm

Model	W	H	D
18/24AAD	970	300	225
24AAE	1078	325	246

3.2 Outdoor Unit

GWH18AAD-K6DNA1A/O

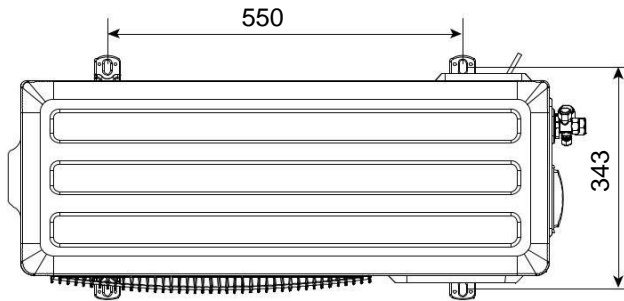
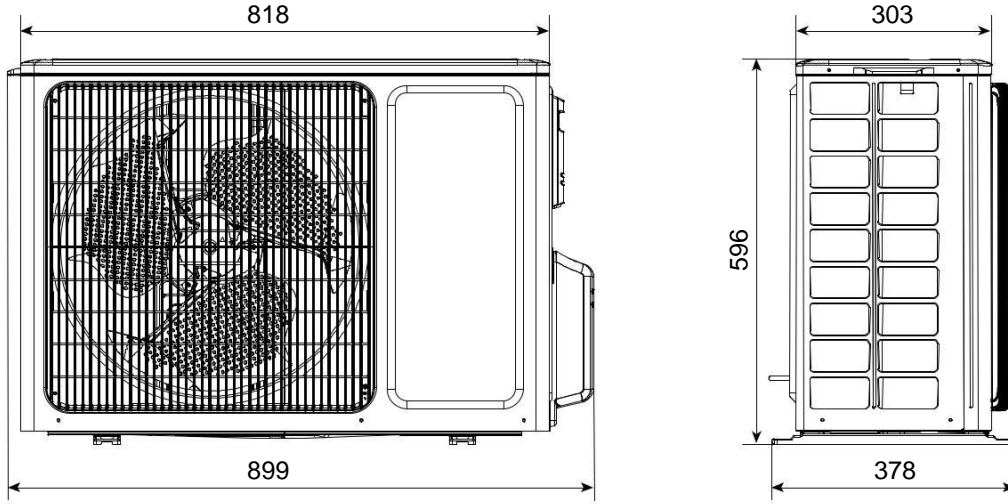

Unit:mm

24K

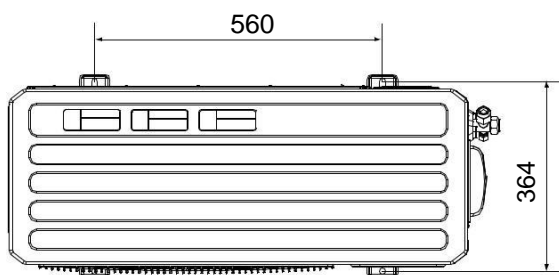
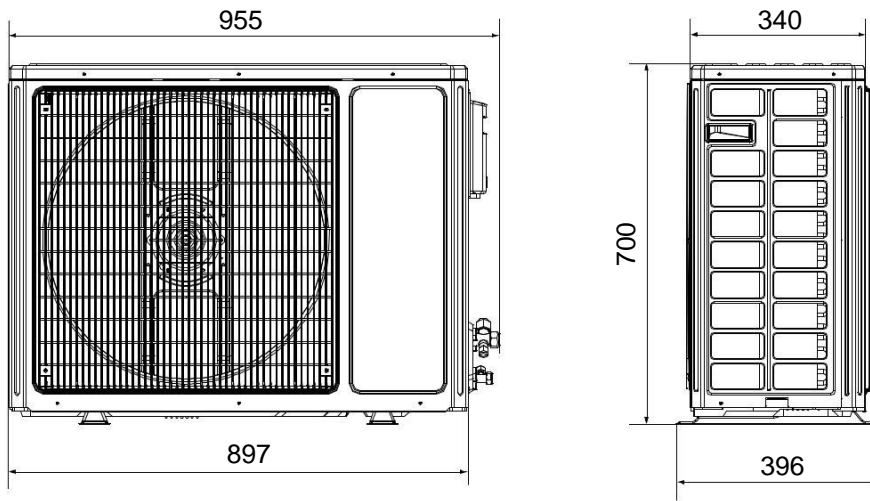

Unit:mm

● ● ● ● ● ● ● Technical Information

4. Refrigerant System Diagram

GWH18AAD-K6DNA1A GWH18AAD-K6DNA5A GWH18AAD-K6DNA4A GWH18AAD-K6DNA2A
 GWH24AAD-K6DNA1A GWH24AAD-K6DNA5A GWH24AAD-K6DNA4A GWH24AAD-K6DNA5A
 GWH24AAD-K6DNA2A GWH24AAE-K6DNA4C

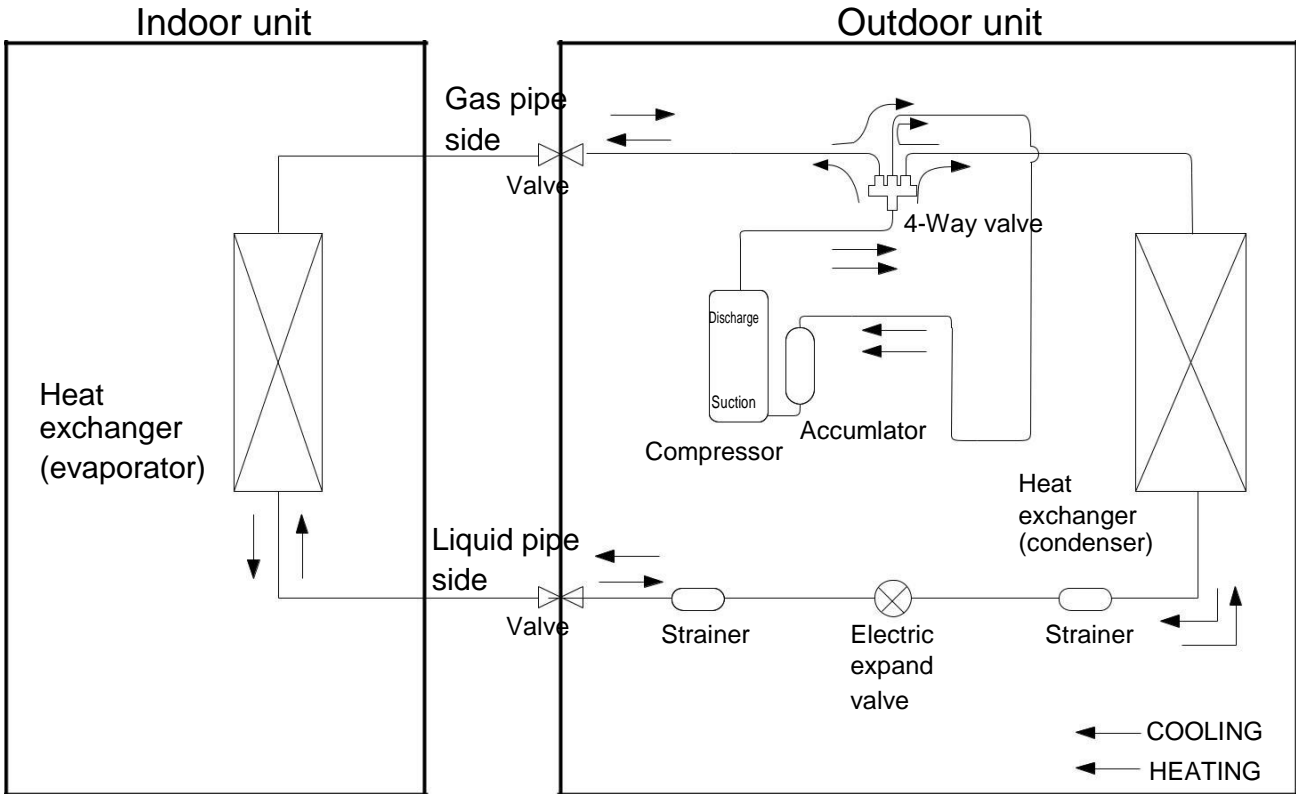

GWH18AAD-K6DNA1B GWH18AAD-K6DNA5B GWH18AAD-K6DNA4B GWH18AAD-K6DNA5B

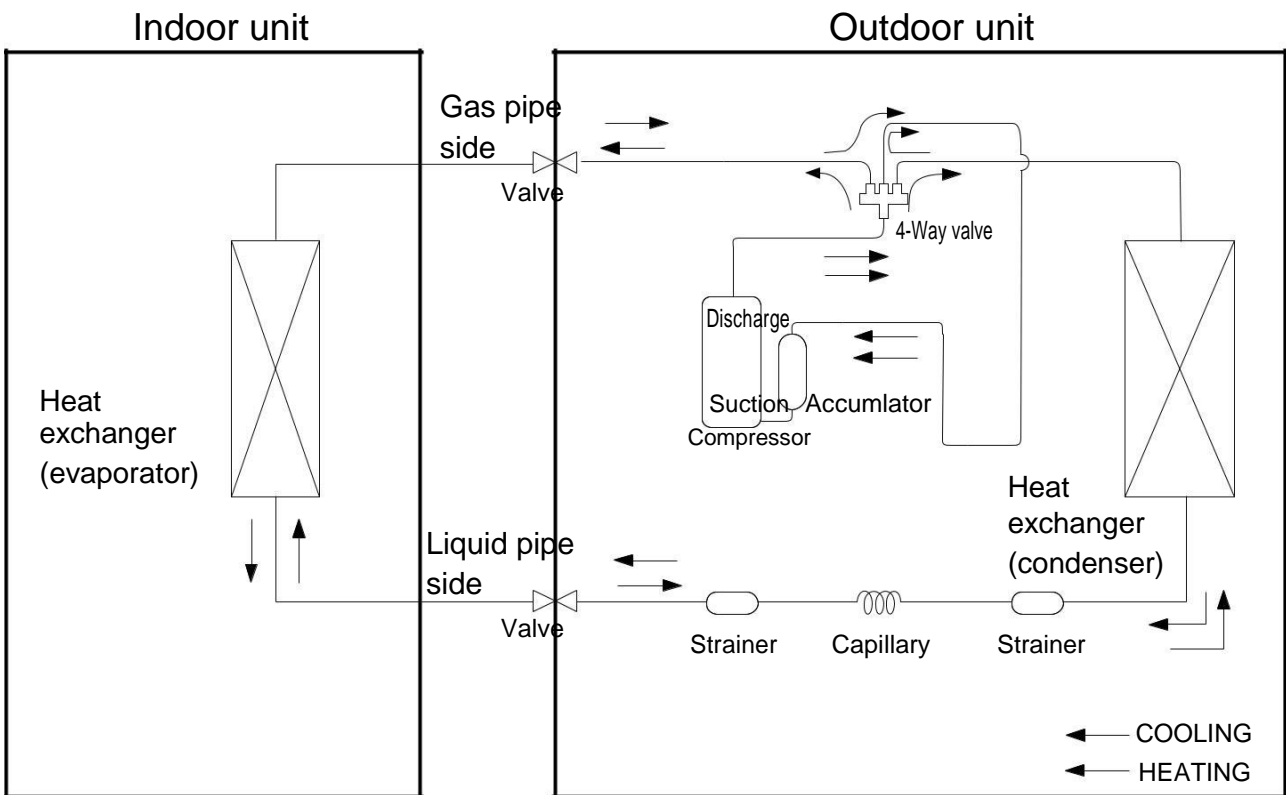

Connection pipe specification:

Liquid pipe: 1/4" (6mm)

Gas pipe: 3/8" (9.52mm) GWH18AAD-K6DNA1B GWH18AAD-K6DNA5B GWH18AAD-K6DNA4B

Gas pipe: 1/2" (12mm) 18K except GWH18AAD-K6DNA1B GWH18AAD-K6DNA5B GWH18AAD-K6DNA4B

Gas pipe: 5/8" (16mm) 24K

5. Electrical Part

5.1 Wiring Diagram

• Instruction

Symbol	Symbol Color	Symbol	Symbol Color	Symbol	Name
WH	White	GN	Green	CAP	Jumper cap
YE	Yellow	BN	Brown	COMP	Compressor
RD	Red	BU	Blue	⊕	Grounding wire
YEGN	Yellow/Green	BK	Black	/	/
VT	Violet	OG	Orange	/	/

Note: Jumper cap is used to determine fan speed and the swing angle of horizontal lover for this model.

• Indoor Unit

All models is except: GWH24AAE-K6DNA4C/I GWH18AAD-K6DNA1A/I(CB476N00201)
 GWH24AAD-K6DNA1A/I(CB476N00101) GWH18AAD-K6DNA5B/I GWH24AAD-K6DNA5A/I
 GWH24AAD-K6DNA4A/I GWH18AAD-K6DNA2A/I GWH24AAD-K6DNA2A/I GWH18AAD-
 K6DNA4B/I(CB479N01301)

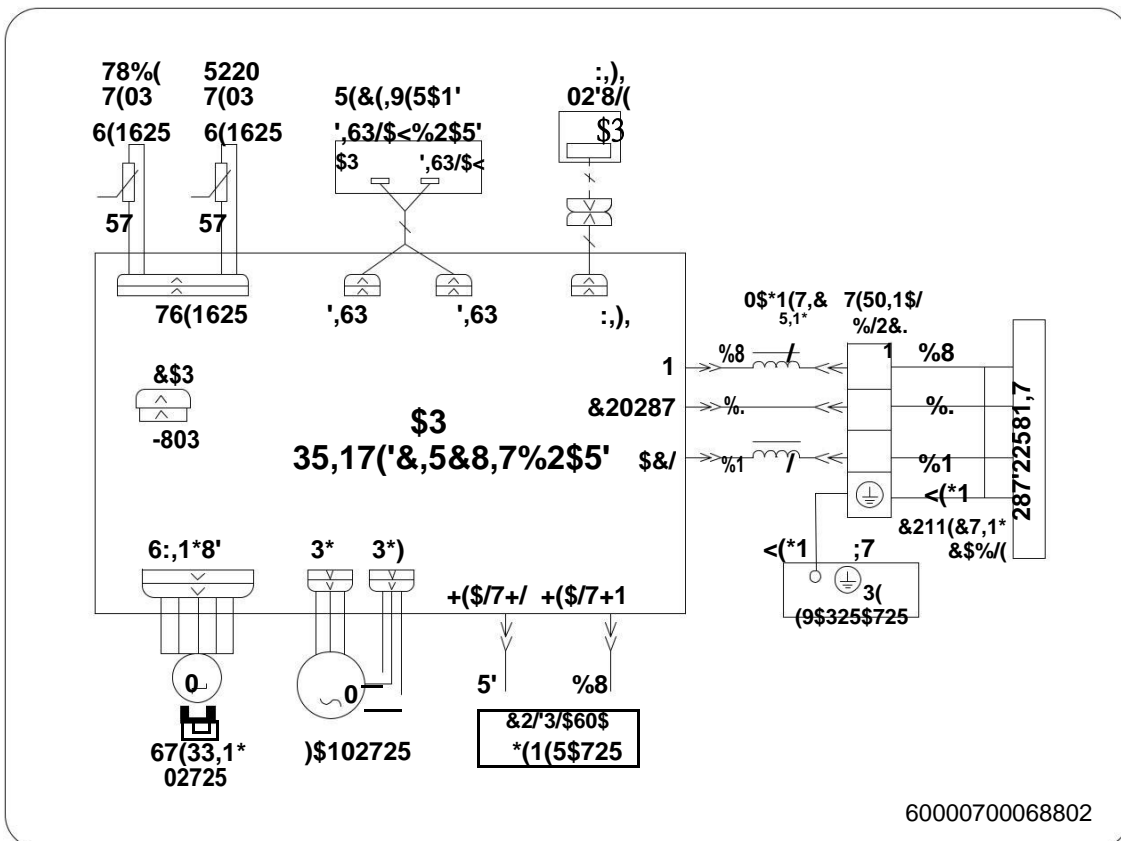

GWH24AAE-K6DNA4C/I

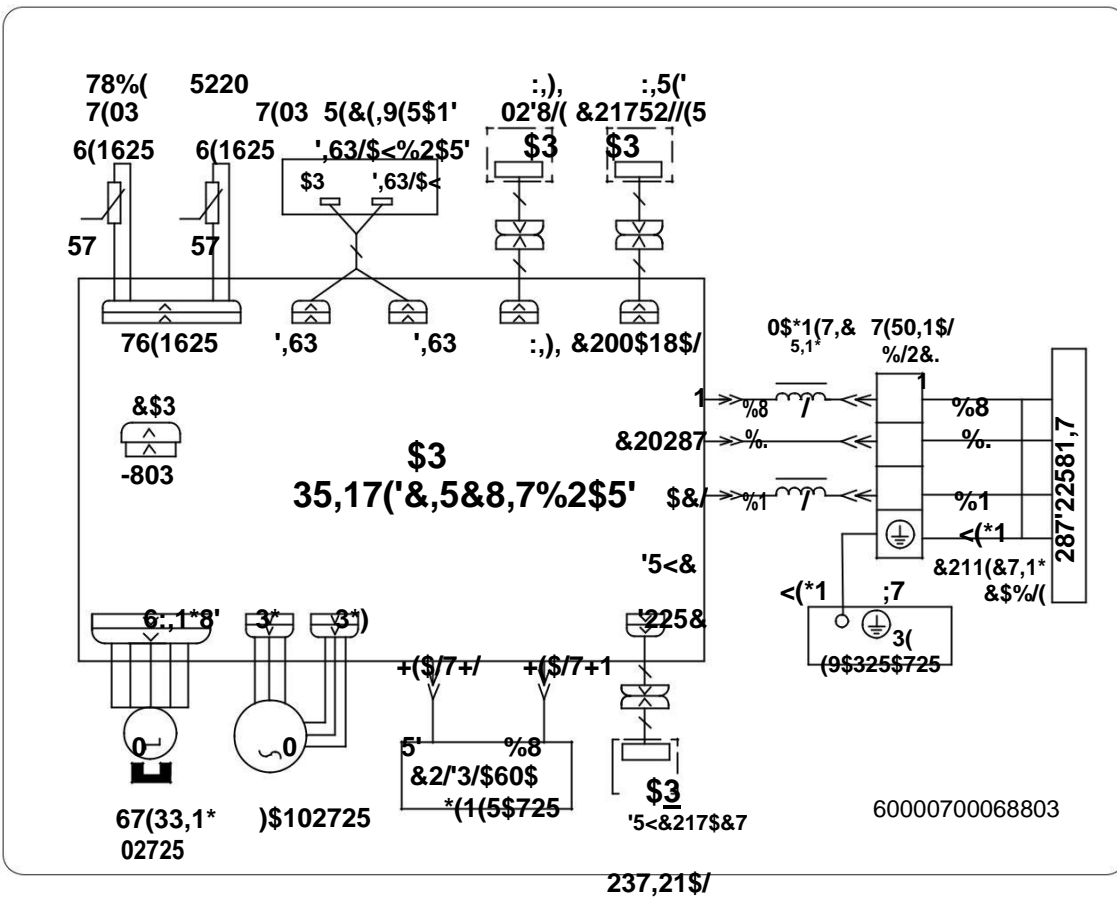

GWH18AAD-K6DNA1A/I(CB476N00201) GWH24AAD-K6DNA1A/I(CB476N00101) GWH18AAD-K6DNA5B/I GWH24AAD-K6DNA5A/I GWH24AAD-K6DNA4A/I GWH18AAD-K6DNA2A/I GWH24AAD-K6DNA2A/I GWH18AAD-K6DNA4B/I(CB479N01301)

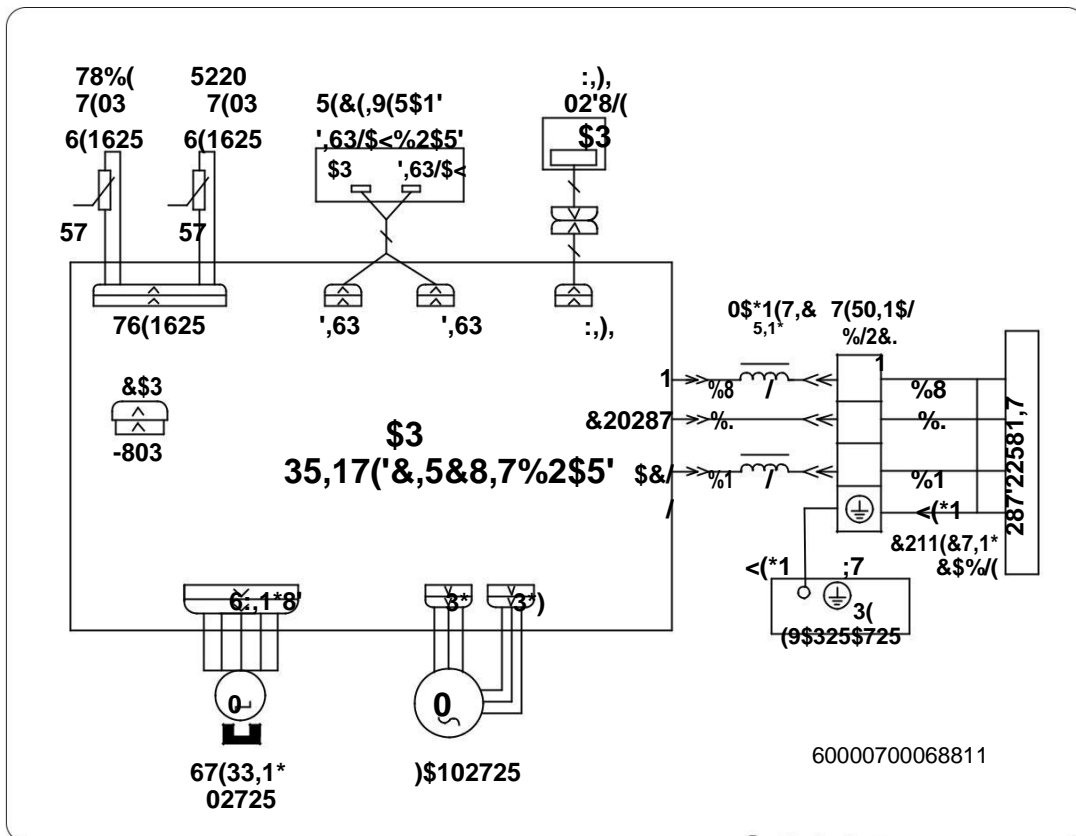

● Outdoor Unit

GWH18AAD-K6DNA1A/O GWH24AAD-K6DNA1A/O GWH24QE-K6DNA1C/O

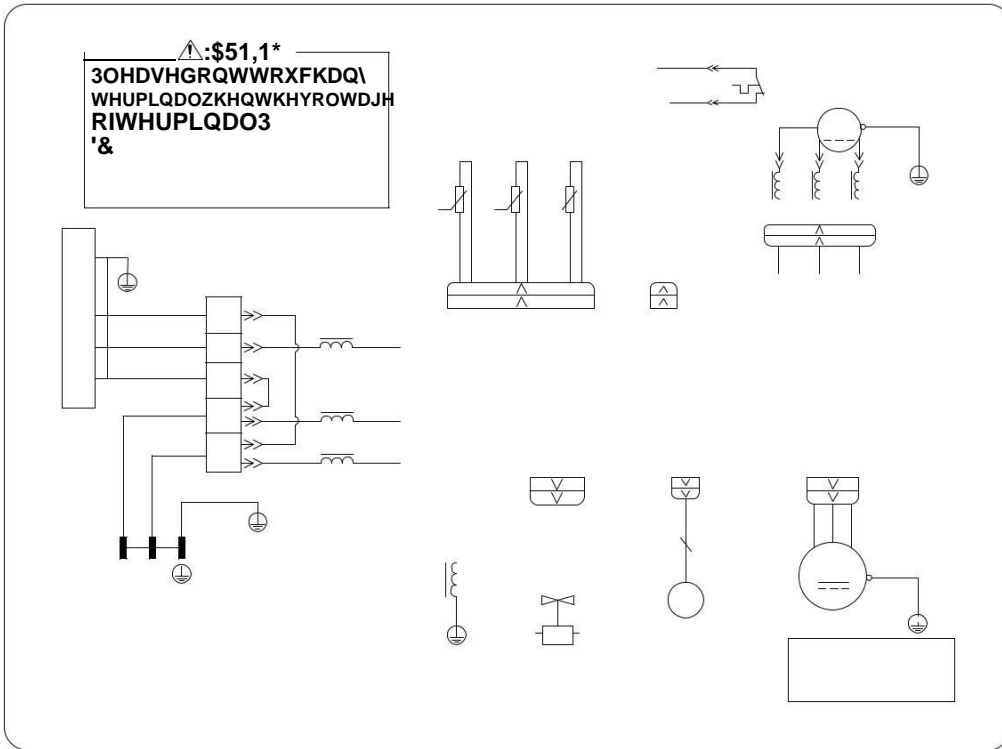

DW\$3LVKLJKHU
 WKDQ9WRSUHYHQWVKH
 ULVNRIHOHFVULFVKRFN

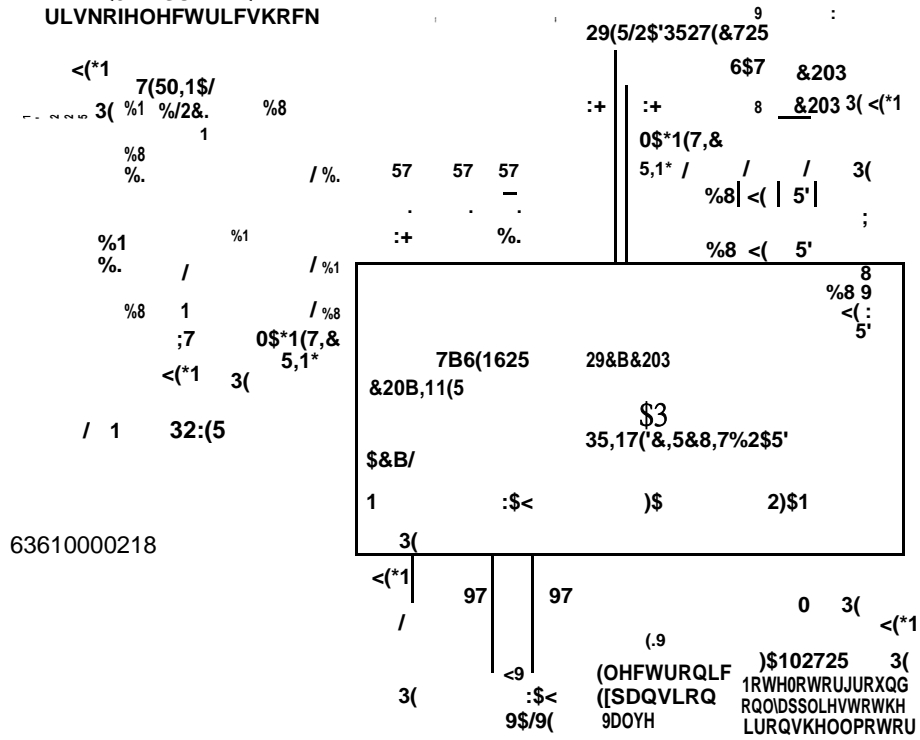

GWH18AAD-K6DNA1B/O

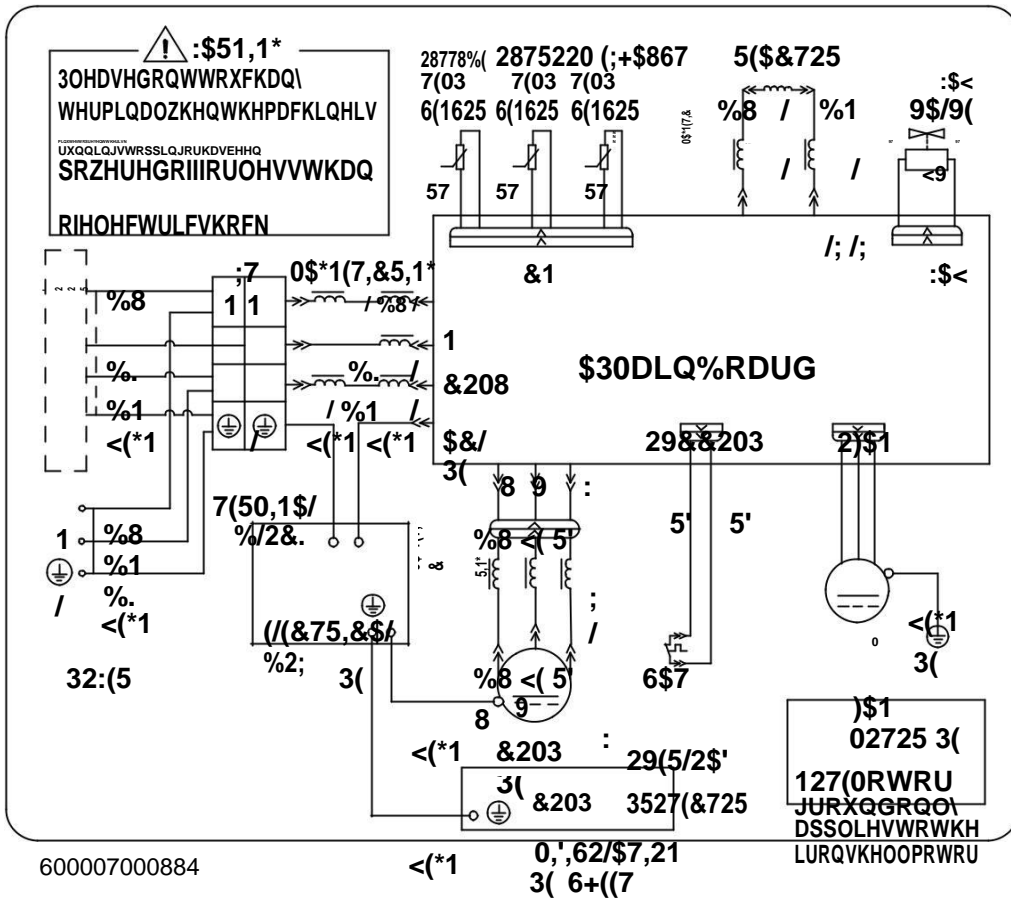

These wiring diagrams are subject to change without notice; please refer to the one supplied with the unit.

Outdoor Unit
GWH18AAD-K6DNA1A/O
24K

• Top view

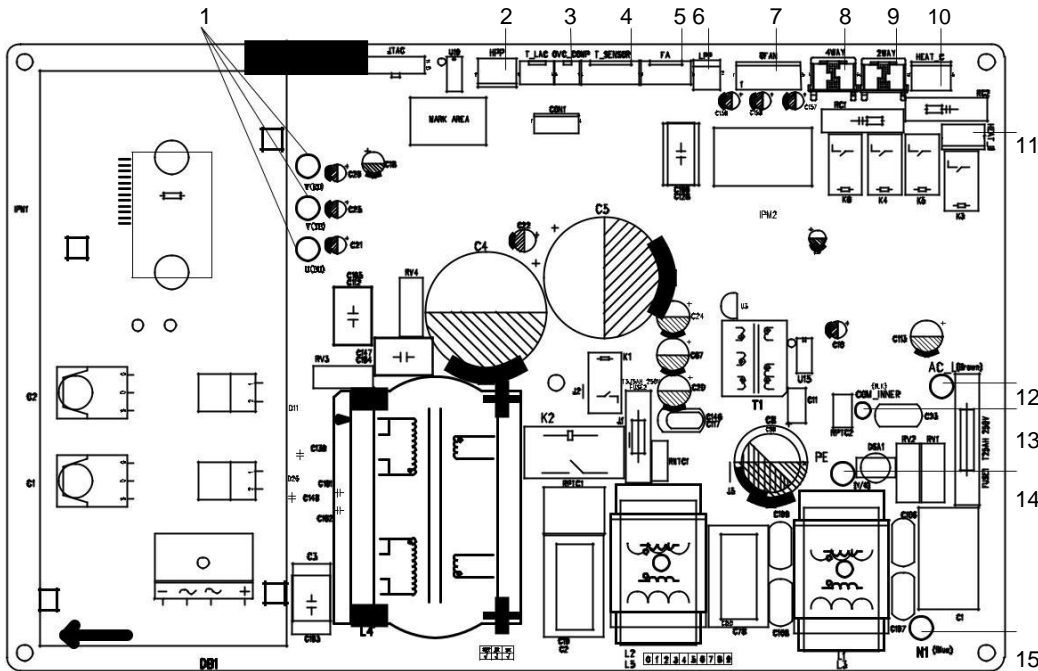

• Bottom view

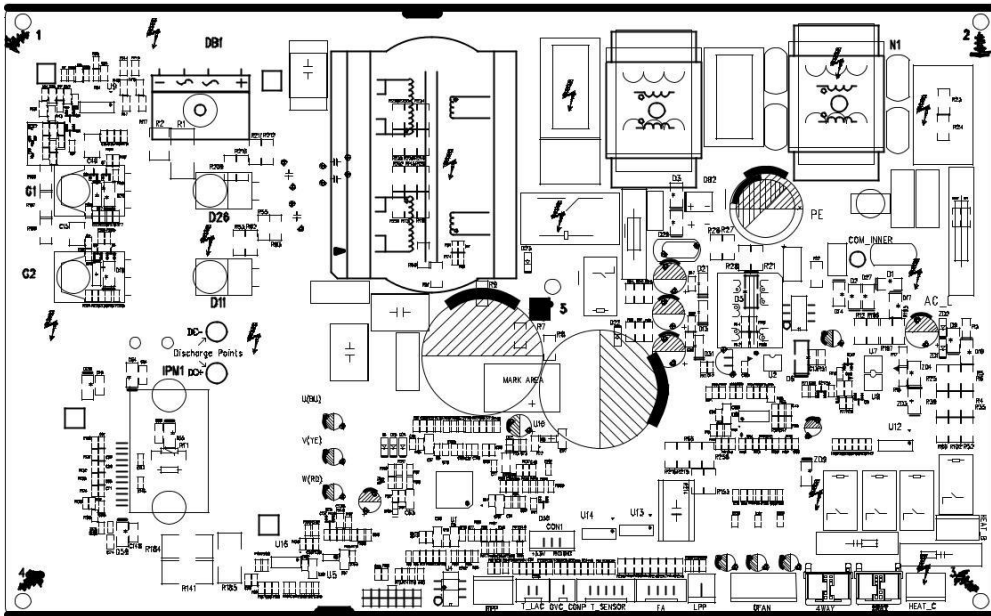

6. Function and Control

6.1 Remote Controller Introduction

Buttons on remote controller

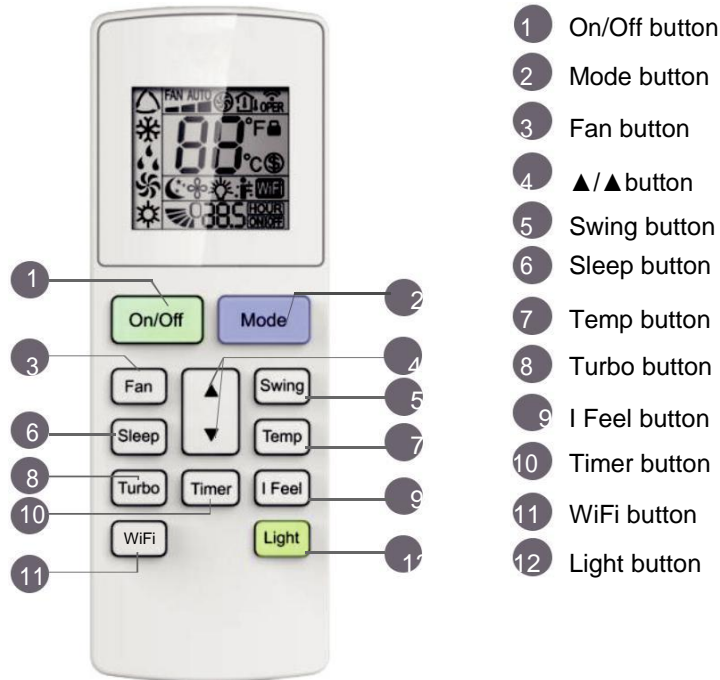

- 1 On/Off button
- 2 Mode button
- 3 Fan button
- 4 ▲/▲ button
- 5 Swing button
- 6 Sleep button
- 7 Temp button
- 8 Turbo button
- 9 I Feel button
- 10 Timer button
- 11 WiFi button
- 12 Light button

Icon Display on Remote Controller

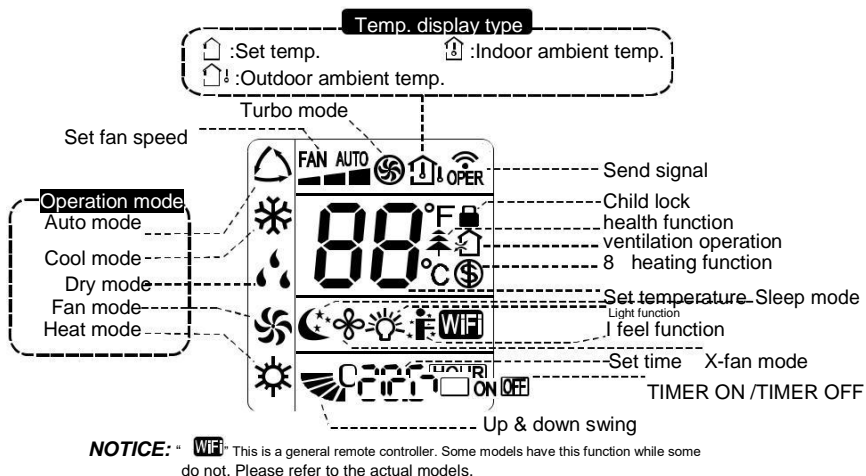

Operation introduction of remote controller

Note: "WiFi" This is a general remote controller. Some models have this function while some do not. Please refer to the actual models.

This is a general use remote controller, it could be used for the air conditioners with multifunction; For some function, which the model doesn't have, if press the corresponding button on the remote controller that the unit will keep the original running status. After putting through the power, the air conditioner will give out a sound. Operation indicator "I" is ON (red indicator, the colour is different for different models). After that, you can operate the air conditioner by using remote controller.

Under on status, pressing the button on the remote controller, the signal icon "📶" on the display of remote controller will blink once and the air conditioner will give out a "de" sound, which means the signal has been sent to the air conditioner.

Under off status, set temperature and clock icon will be displayed on the display of remote controller (If timer on, timer off and light functions are set, the corresponding icons will be displayed on the display of remote controller at the same time); Under on status, the display will show the corresponding set function icons.

1. ON/OFF button

Press this button to turn on the unit. Press this button again to turn off the unit.



2. MODE button

Each time you press this button, a mode is selected in a sequence that goes from AUTO, COOL, DRY, FAN, and HEAT*, as the following:

* Note: Only for models with heating function.



3. FAN button

This button is used for setting Fan Speed in the sequence that goes from AUTO, , , to , then back to Auto.

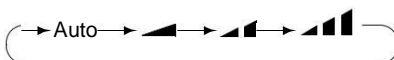

* Note: Fan speed under dry mode is low speed.

X-FAN function: Hold fan speed button for 2s in COOL or DRY mode, the icon  is displayed and the indoor fan will continue operation for a few minutes in order to dry the indoor unit even though you have turned off the unit. After energization, X-FAN OFF is defaulted. X-FAN is not available in AUTO, FAN or HEAT mode.

This function indicates that moisture on evaporator of indoor unit will be blown after the unit is stopped to avoid mould.

Having set X-FAN function on: After turning off the unit by pressing ON/OFF button indoor fan will continue running for a few minutes. at low speed. In this period, Hold fan speed button for 2s to stop indoor fan directly.

Having set X-FAN function off: After turning off the unit by pressing ON/OFF button, the complete unit will be off directly.

4. ▲ / ▼ button

Press ▲ / ▼ button to increase/decrease set temperature. In AUTO mode, set temperature is not adjustable.

When setting Timer On or Timer Off, press "▲" or "▼" button to adjust the time.

5. SWING button

Press this button to set up & down swing angle.

6. SLEEP button

Under Cool, Heat mode, press this button to turn on Sleep function. Press this button again to cancel Sleep function.

Under Fan, DRY and Auto modes, this function is unavailable.

7. TEMP button

Press this button, you can see indoor set temperature, indoor ambient temperature on indoor unit's display.

The setting on remote controller is selected circularly as below:

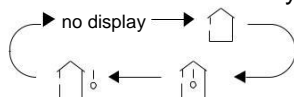



Note:

Outdoor temperature display is not available for some models. At that time, indoor unit receives " " signal, while it displays indoor set temperature.

8. TURBO button

Under COOL or HEAT mode, press this button to activate / deactivate the Turbo function.

9. I FEEL button

Press this button to start I FEEL function and "  " will be displayed on the remote controller. After this function is set, the remote controller will send the detected ambient temperature to the controller and the unit will automatically adjust the indoor temperature according to the detected temperature. Press this button again to close I FEEL function and "  " will disappear. When I FEEL function is turned on, the remote controller should be put within the area where indoor unit can receive the signal sent by the remote controller.

10. Timer button

Under ON status, press this button to set timer OFF; Under OFF status, press this button to set timer ON.

Press this button once and the characters of HOUR ON (OFF) will flash to be displayed. Meanwhile, press "▲" button or "▲" button to adjust timer setting (time will change quickly if holding "▲" or "▲" button). Time setting range is 0.5~24hours.

Press this button again to confirm timer setting and the characters of HOUR ON (OFF) will stop flashing.

If the characters are flashing but you haven't press timer button, timer setting status will be quit after 5s.

If timer is confirmed, press this button again to cancel timer.

11. WiFi button

Press "WiFi" button to turn on or turn off WiFi function. When WiFi function is turned on, the "WiFi" icon will be displayed on remote controller; Under status of unit off, press "MODE" and "WiFi" buttons simultaneously for 1s, WiFi module displayed on remote controller; Under status will restore to factory default setting.



This function is only available for some models.

12. LIGHT button

Press this button to turn on the display's light and press this button again to turn off the display's light.

Function introduction for combination buttons

Combination of "▲" and "▲" buttons: About lock

Press "▲" and "▲" buttons simultaneously 3s to lock or unlock the keypad. If the remote controller is locked,  displayed. In this case, pressing any button,  blinks three times.

Combination of "MODE" and "▲" buttons: About switch between Fahrenheit and centigrade

At unit OFF, press "MODE" and "▲" buttons simultaneously to switch between and .

Combination of "TEMP" and "TIMER" buttons: About Energy-saving Function

Press "TEMP" and "TIMER" simultaneously in COOL mode to start energy-saving function. Nixie tube on the remote controller displays "SE". Repeat the operation to quit the function.

Combination of "TEMP" and "TIMER" buttons: About 8 Heating Function

Press "TEMP" and "TIMER" simultaneously in HEAT mode to start 8Heating Function Nixie tube on the remote controller displays "  " and a selected temperature of "8 ". (46 if Fahrenheit is adopted). Repeat the operation to quit the function.

WiFi Function

Press this button to turn on the unit. Press this button again to turn off the unit. Press "MODE" and "TURBO" button simultaneously to turn on or turn off WiFi function. When WiFi function is turned on, the "WiFi" icon will be displayed on remote controller; Long press "MODE" and "TURBO" buttons simultaneously for 10s, remote controller will send WiFi reset code and then the WiFi function will be turned on. WiFi function is defaulted ON after energization of the remote controller. This function is only available for some models.

Replacement of batteries in remote controller

1. Press the back side of remote controller marked with "OFF", as shown in the fig, and then push out the cover of battery box along the arrow direction.
2. Replace two 7# (AAA 1.5V) dry batteries, and make sure the position of "+" polar and "-" polar are correct.
3. Reinstall the cover of battery box.

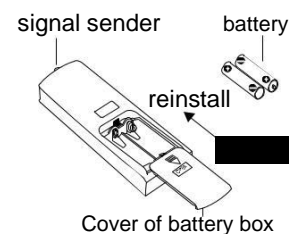

Emergency operation

If remote controller is lost or damaged, please use auxiliary button to turn on or turn off the air conditioner. The operation in details are as below:

As shown in the fig. Open panel, press aux. button to turn on or turn off the air conditioner. When the air conditioner is turned on, it will operate under auto mode.

WARNING:

Use insulated object to press the auto button

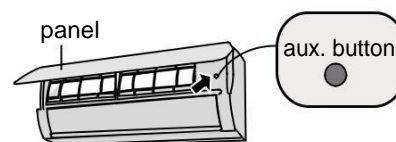

6.2 GREE+ App Operation Manual

Control Flow Chart

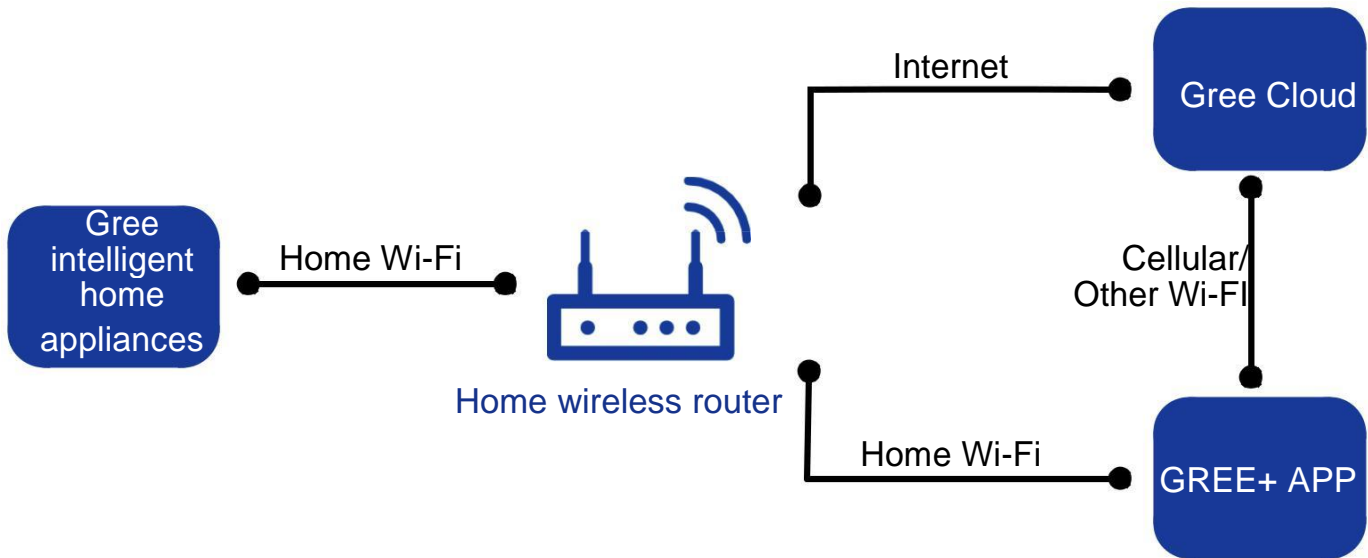

Operating Systems

Requirement for User's smart phone:



iOS system
Support iOS7.0 and
above version



Android system Support
Android 4.4 and above
version

Download and installation



GREE+ App Download Linkage

Scan the QR code or search "GREE+" in the application market to download and install it. When "GREE+" App is installed, register the account and add the device to achieve long-distance control and LAN control of Gree smart home appliances. For more information, please refer to "Help" in App.

6.3 Ewpe Smart App Operation Manual

Control Flow Chart

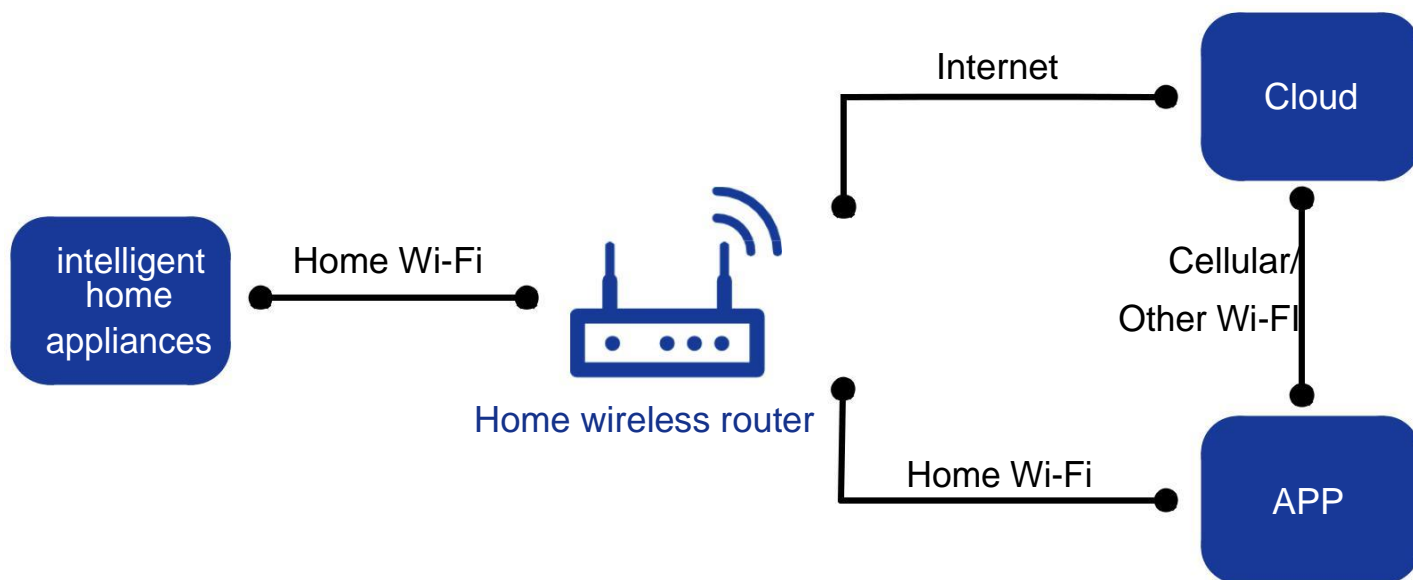

Operating Systems

Requirement for User's smart phone:

 iOS system
Support iOS7.0 and above version

 Android system
Support Android 4.4 and above version

Download and installation



App Download Linkage

Scan the QR code or search "Ewpe Smart" in the application market to download and install it. When "Ewpe Smart" App is installed, register the account and add the device to achieve long-distance control and LAN control of smart home appliances. For more information, please refer to "Help" in App.

6.4 Brief Description of Modes and Functions

1. Basic function of system

(1) Cooling mode

- (1) Under this mode, fan and swing operates at setting status. Temperature setting range is 16~30°C.
- (2) During malfunction of outdoor unit or the unit is stopped because of protection, indoor unit keeps original operation status.

(2) Drying mode

- (1) Under this mode, fan operates at low speed and swing operates at setting status. Temperature setting range is 16~30°C.
- (2) During malfunction of outdoor unit or the unit is stopped because of protection, indoor unit keeps original operation status.
- (3) Protection status is same as that under cooling mode.
- (4) Sleep function is not available for drying mode.

(3) Heating mode

- (1) Under this mode, Temperature setting range is 16~30°C.
- (2) Working condition and process for heating mode:

When turn on the unit under heating mode, indoor unit enters into cold air prevention status. When the unit is stopped or at OFF status, and indoor unit has been started up just now, the unit enters into residual heat-blowing status.

(4) Working method for AUTO mode:

1. Working condition and process for AUTO mode:

a. Under AUTO mode, standard heating $T_{\text{preset}}=20^{\circ}\text{C}$ and standard cooling $T_{\text{preset}}=25^{\circ}\text{C}$. The unit will switch mode automatically according to ambient temperature.

2. Protection function

- a. During cooling operation, protection function is same as that under cooling mode.
- b. During heating operation, protection function is same as that under heating mode.

3. Display: Set temperature is the set value under each condition. Ambient temperature is ($T_{\text{amb.}}-T_{\text{compensation}}$) for heat pump unit and $T_{\text{amb.}}$ for cooling only unit.

4. If theres I feel function, $T_{\text{compensation}}$ is 0. Others are same as above.

(5) Fan mode

Under this mode, indoor fan operates at set fan speed. Compressor, outdoor fan, 4-way valve and electric heating tube stop operation. Indoor fan can select to operate at high, medium, low or auto fan speed. Temperature setting range is 16~30°C.

2. Other control

(1) Buzzer

Upon energization or availably operating the unit or remote controller, the buzzer will give out a beep.

(2) Auto button

If press this auto button when turning off the unit, the complete unit will operate at auto mode. Indoor fan operates at auto fan speed and swing function is turned on. Press this auto button at ON status to turn off the unit.

(3) Auto fan

Heating mode: During auto heating mode or normal heating ode, auto fan speed will adjust the fan speed automatically according to ambient temperature and set temperature.

(4) Sleep

After setting sleep function for a period of time, system will adjust set temperature automatically.

(5) Timer function:

General timer and clock timer functions are compatible by equipping remote controller with different functions.

(6) Memory function

memorize compensation temperature, off-peak energization value.

Memory content: mode, up&down swing, light, set temperature, set fan speed, general timer (clock timer cant be memorized). After power recovery, the unit will be turned on automatically according to memory content.

(7) Health function

During operation of indoor fan, set health function by remote controller. Turn off the unit will also turn off health function. Turn on the unit by pressing auto button, and the health is defaulted ON.

(8)I feel control mode

After controller received I feel control signal and ambient temperature sent by remote controller, controller will work according to the ambient temperature sent by remote controller.

(9)Compulsory defrosting function**(1) Start up compulsory defrosting function**

Under ON status, set heating mode with remote controller and adjust the temperature to 16°C. Press “+, -, +, -, +,-” button successively within 5s and the complete unit will enter into compulsory defrosting status. Meanwhile, heating indicator on indoor unit will ON 10s and OFF 0.5s successively. (Note: If complete unit has malfunction or stops operation due to protection, compulsory defrosting function can be started up after malfunction or protection is resumed.)

(2) Exit compulsory defrosting mode

After compulsory defrosting is started up, the complete unit will exit defrosting operation according to the actual defrosting result, and the complete unit will resume normal heating operation.

(10)Refrigerant recovery function:**(1) Enter refrigerant recycling function**

Within 5min after energizing (unit ON or OFF status is ok), continuously press LIGHT button for 3 times within 3s to enter refrigerant recycling mode; Fo is displayed and refrigerant recycling function is started. At this moment, the maintenance people closes liquid valve. After 5min, stick the thimble of maintenance valve with a tool. If there is no refrigerant spraying out, close the gas valve immediately and then turn off the unit to remove the connection pipe.

(2) Exit refrigerant recycling function

After entering refrigerant recycling mode, when receive any remote control signal or enter refrigerant recycling mode for 25min, the unit will exit refrigerant recycling mode automatically. If the unit is in standby mode before refrigerant recycling, it will be still in standby mode after finishing refrigerant recycling; if the unit is in ON status before refrigerant recycling, it will still run in original operation mode.

(11)Ambient temperature display control mode

1. When user set the remote controller to display set temperature (corresponding remote control code: 01), current set temperature will be displayed.

2. Only when remote control signal is switched to indoor ambient temperature display status (corresponding remote control code: 10) from other display status (corresponding remote control code: 00, 01,11),controller will display indoor ambient temperature for 3s and then turn back to display set temperature.

Under this mode, indoor fan operates at set fan speed. Compressor, outdoor fan, 4-way valve and electric heating tube stop operation.

Indoor fan can select to operate at high, medium, low or auto fan speed. Temperature setting range is 16~30°C.

(12)Off-peak energization function:

Adjust compressors minimum stop time. The original minimum stop time is 180s and then we change to:

The time interval between two start-ups of compressor can't be less than $180+T$ s ($0 \leq T \leq 15$). T is the variable of controller. That's to say the minimum stop time of compressor is 180s~195s. Read-in T into memory chip when refurbish the memory chip each time. After power recovery, compressor can only be started up after $180+T$ s at least.

(13) SE control mode

The unit operates at SE status.

(14) X-fan mode

When X-fan function is turned on, after turn off the unit, indoor fan will still operate at low speed for 2min and then the complete unit will be turned off. When x-fan function is turned off, after turn off the unit, the complete unit will be turned off directly.

(15) 8°C heating function

Under heating mode, you can set 8°C heating function by remote controller. The system will operate at 8°C set temperature.

(16) Turbo fan control function

Set turbo function under cooling or heating mode to enter into turbo fan speed. Press fan speed button to cancel turbo wind. No turbo function under auto, dry or fan mode.

Outdoor Units

1. Input Parameter Compensation and Calibration

(1) Check the ambient temperature compensation function Indoor ambient temperature compensation function.

a. In cooling mode, the indoor ambient temperature participating in computing control = (T_{indoor ambient temperature} - Δ T_{cooling indoor ambient temperature compensation})

b. In heating mode, the indoor ambient temperature participating in computing control = (T_{indoor ambient temperature} - Δ T_{heating indoor ambient temperature compensation})

(2) Check effective judgment controls of parameters

Effective judgment function of the outdoor exhaust temperature thermo-bulb When conditions a and b are satisfied, the outdoor exhaust temperature thermo-bulb is judged not to be connected into place, the mainboard of outer units will display failure of the outdoor exhaust temperature thermo-bulb (not connected into place), stop the machine for repairing, and resume the machine by remote controls of ON/ OFF.

a. Judgment of exhaust detection temperature change:

After the compressor starts up and runs for 10 minutes, if the compressor frequency $f \geq 40\text{Hz}$, and the rising value T_{exhaust} (T_{exhaust} (after start-up for 10 minutes) - T_{exhaust} (before start-up)) $< 2^{\circ}\text{C}$, the outdoor exhaust temperature thermo-bulb can be judged not to be connected into place (judging once when the power is on the first time).

b. Comparative judgment of exhaust detection temperature and condenser detection temperature ($T_{\text{pipe temperature}} = T_{\text{outdoor pipe temperature}}$ in cooling mode, $T_{\text{pipe temperature}} = T_{\text{indoor pipe temperature}}$ in heating mode): After the compressor starts up and runs for 10 minutes, if the compressor frequency $f \geq 40\text{Hz}$, and $T_{\text{pipe temperature}} \geq (T_{\text{exhaust}} + 3)$, the outdoor exhaust temperature thermobulb can be judged not to be connected into place (judging once when power is on the first time).

- (T_{indoor ambient temperature}

- (T_{indoor ambient temperature}

- Δ T_{cooling indoor ambient temperature compensation}) $\leq 0.5^{\circ}\text{C}$, start up the machine

- Δ T_{cooling indoor ambient temperature compensation}) $< 2^{\circ}\text{C}$, the cooling operation

- Δ T_{cooling indoor ambient temperature compensation}), the cooling operation will

2. Basic Functions

(1) Cooling Mode

1. Conditions and processes of cooling operation:

(1) If the compressor is shut down, and $[T_{\text{set up}} - (T_{\text{indoor ambient temperature}}$

for cooling, the cooling operation will start;

(2) During operations of cooling, if $0^{\circ}\text{C} \leq [T_{\text{set up}}$

will be still running;

(3) During operations of cooling, if $2^{\circ}\text{C} \leq [T_{\text{set up}}$

stop after reaching the temperature point.

2. Temperature setting range

(1) If $T_{\text{outdoor ambient temperature}} \geq [T_{\text{low-temperature cooling temperature}}]$, the temperature can be set at: 16~30°C (Cooling at room temperature);

(2) If $T_{\text{outdoor ambient temperature}} < [T_{\text{low-temperature cooling temperature}}]$, the temperature can be set at: 25~30°C (Cooling at low temperature), that is, the minimum setting temperature for outer units judgment is 25°C.

(2) Dehumidifying Mode

1. Conditions and processes of dehumidifying operations: Same as the cooling mode;

2. The temperature setting range is: 16~30°C ;

(3) Air-supplying Mode

1. The compressor, outdoor fans and four-way valves are switched off;

2. The temperature setting range is: 16~30°C.

(4) Heating Mode

1. Conditions and processes of heating operations: (T_{indoor ambient temperature} is the actual detection temperature of indoor environment thermo-bulb, T_{heating indoor ambient temperature compensation} is the indoor ambient temperature compensation during heating operations)

(1) If the compressor is shut down, and $[(T_{\text{indoor ambient temperature}} - \Delta T_{\text{heating indoor ambient temperature compensation}}) - T_{\text{set up}}] \leq 0.5^{\circ}\text{C}$, start the machine to enter into heating operations for heating;

(2) During operations of heating, if $0^{\circ}\text{C} \leq [(T_{\text{indoor ambient temperature}} - \Delta T_{\text{heating indoor ambient temperature compensation}}) - T_{\text{set up}}] < 2^{\circ}\text{C}$, the heating

operation will be still running;

(3) During operations of heating, if $2^{\circ}\text{C} \leq [(T_{\text{indoor ambient temperature}} - \Delta T_{\text{heating indoor ambient temperature compensation}}) - T_{\text{set up}}]$, the heating operation will stop after reaching the temperature point.

2. The temperature setting range in this mode is: 16~30°C .

3. Special Functions

Defrosting Control

① Conditions for starting defrosting

After the time for defrosting is judged to be satisfied, if the temperature for defrosting is satisfied after detections for continuous 3minutes, the defrosting operation will start.

② Conditions of finishing defrosting

The defrosting operation can exit when any of the conditions below is satisfied:

③ $T_{\text{outdoor pipe temperature}} \geq (T_{\text{outdoor ambient temperature}} - [T_{\text{temperature 1 of finishing defrosting}}])$;

④ The continuous running time of defrosting reaches [tmax. defrosting time].

4. Control Logic

(1) Compressor Control

Start the compressor after starting cooling, heating, dehumidifying operations, and the outer fans start for 5s; When the machine is shutdown, in safety stops and when switching to air-supplying mode, the compressor will stop immediately. In all modes: once the compressor starts up, it will not be allowed to stop until having run for the [tmin. compressor running time] (Note: including cases of shutdown when the temperature point is reached; except the cases requiring stopping the compressor such as fault protection, remote shutdown, mode switching etc.); In all modes: once the compressor stops, it will be allowed be restart after 3-minute delay (Note: The indoor units have a function of power memory, the machine can be restarted after remote shutdown and powering up again without delay).

1. Cooling mode

Start the machine to enter into cooling operation for cooling, the compressor is switched on.

2. Dehumidifying mode

Same as the cooling mode.

3. Air-supplying mode

The compressor is switched off.

4. Heating mode

(1) Start the machine to enter into heating operation for heating, the compressor is switched on.

(2) Defrosting:

a. Defrosting starts: the compressor is shut down, and restarts it after 55-second delay.

b. Defrosting ends: the compressor stops, then starts it after 55-second delay.

(2) Outer Fans Control

Notes:

Only the outer fans run for at least 80s in each air flow speed can the air flow be switched;

After the outer fans run compulsively in high speed for 80s when the machine starts up, control the air flow according to the logic.

After remote shutdown, safety stops, and when the machine stops after reaching the temperature point, as well as after the compressor stops, extend 1 minute, the outer fans will stop (During the period in the 1 minute, the air flow of outer fans can be changed according to the outdoor ambient temperature changes); When running with force, the outdoor fans shall run in the highest air flow.

(3) 4-way valve control

1. The 4-way valve control under the modes of Cooling, dehumidification and supplying air: closing;

2. The status of 4-way valve control under the heating mode: getting power;

(1) 4-way valve power control under heating mode

Starts the machine under heating mode, the 4-way valve will get power immediately.

(2) 4-way valve power turn-off control under heating mode

a. When you should turn off the power or switch to other mode under heating mode, the power of 4-way valve will be cut after 2 minutes of the compressor stopped.

b. When all kinds of protection stops, the power of 4-way valve will be cut after delaying 4 minutes.

(3) Defrosting control under heating mode:

a. Defrosting begins: The power of 4-way valve will be cut after 50s of entering into the defrosting compressor.

b. Defrosting stops: The 4-way valve will get power after 50s of exiting the defrosting compressor.

(4) Evaporator frozen-preventing protection function

At the mode of Cooling, dehumidifying:

Evaporator frozen-preventing protection function is allowed to begin after 6 min of starting the compressor.

1. Starting estimation:

After the compressor stopped working for 180s, if $T_{\text{inner pipe}} > [T_{\text{frozen-preventing frequency-limited temperature}}$ (the temperature of hysteresis is 2), the machine is only allowed to start for operating, otherwise it should not be started, and should be stopped to treat according to the frozen-preventing protection: Clear the trouble under the mode of power turn-off / heating, and the protection times are not counted.

2. Frequency limited

$[T_{\text{frozen-preventing normal speed frequency-reducing temperature}}] \leq T_{\text{inner pipe}} [T_{\text{frozen-preventing frequency-limited temperature}}]$, you should limit the frequency raising of compressor.

3. Reducing frequency at normal speed:

If $[T_{\text{frozen-preventing high speed frequency-reducing temperature}}] \leq T_{\text{inner pipe}} [T_{\text{frozen-preventing normal speed frequency-reducing temperature}}]$, you should adjust the compressor frequency by reducing 8Hz/90s till the lower limit;

4. Reducing frequency at high speed:

If $[T_{\text{frozen-preventing power turn-off temperature}}] \leq T_{\text{inner pipe}} [T_{\text{frozen-preventing high speed frequency-reducing temperature}}]$ you should adjust the compressor frequency by reducing 30Hz/90s till the lower limit;

5. Power turn-off:

If the $T_{\text{inner pipe}} < [T_{\text{frozen-preventing power turn-off temperature}}]$, then frozen-preventing protect to stop the machine; If $T_{\text{frozen-preventing frequency-limited temperature}} < T_{\text{inner pipe}}$, and the compressor has stopped working for 3 minutes, the whole machine should be allowed to operate.

6. If the frozen-preventing protection power turn-off continuously occurs for six times, it should not be resumed automatically, and you should press the ON/OFF button to resume if the fault keeps on. During the process of running, if the running time of compressor exceeds the t evaporator frozen-preventing protection times zero clearing time , the times of frozen-preventing power turn-off should be cleared to recount. The mode of stopping the machine or transferring to supply air will clear the trouble times immediately (if the trouble can not be resumed, mode transferring will not clear it).

(5) Overload protection function

Overload protection function at the mode of cooling and dehumidifying

1. Starting estimation:

After the compressor stopped working for 180s, if $T_{\text{outer pipe}} < [T_{\text{Cooling overload frequency-limited temperature}}]$ (the temperature of hysteresis is 2°C), the machine is allowed to start, otherwise it should not be started, and should be stopped to treat according to the overload protection: Clear the trouble at the mode of power turn-off / heating, and the protection times are not counted.

2. Frequency limited

If $[T_{\text{Cooling overload frequency-limited temperature}}] \leq T_{\text{outer pipe}} [T_{\text{Cooling overload frequency reducing temperature at normal speed}}]$, you should limit the frequency raising of compressor.

3. Reducing frequency at normal speed and power turn-off:

If $[T_{\text{Cooling overload frequency reducing temperature at high speed}}] \leq T_{\text{outer pipe}} < [T_{\text{Cooling overload power turn-off temperature}}]$, you should adjust the compressor frequency by reducing 8Hz/90s till the lower limit; After it was running 90s at the lower limit, if $[T_{\text{Cooling overload frequency reducing temperature at normal speed}}] \leq T_{\text{outer pipe}}$, then Cooling overload protects machine stopping;

4. Reducing frequency at high speed and stop machine:

If $[T_{\text{Cooling overload frequency reducing temperature at high speed}}] \leq T_{\text{outer pipe}} [T_{\text{Cooling overload power turn-off temperature}}]$, you should adjust the compressor frequency by reducing 30Hz/90s till the lower limit; After it was running 90s at the lower limit, if $[T_{\text{Cooling overload frequency reducing temperature at normal speed}}] \leq [T_{\text{outer pipe}}]$, then Cooling overload protects machine stopping;

5. Power turn-off:

If the $[T_{\text{Cooling overload power turn-off temperature}}] \leq T_{\text{outer pipe}}$, then Cooling overload protects machine stopping; If $[T_{\text{outer pipe}}] < [T_{\text{Cooling overload frequency-limited temperature}}]$ and the compressor has been stopped working for 3 minutes, the machine should be allowed to operate.

6. If the Cooling overload protection power turn-off continuously occurs for six times, it should not be resumed automatically, and you should press the ON/OFF button to resume if the fault keeps on. During the process of running, if the running time of compressor exceeds the t overload protection times zero clearing time , the times of overload protection power turn-off should be cleared to recount. The mode of stopping the machine or transferring to supply air will clear the trouble times immediately (if the trouble can not be resumed, transferring mode will not clear it).

Overload protection function at the mode of

heating Starting estimation :

After the compressor stopped working for 180s, if $T_{\text{inner pipe}} > T_{\text{heating overload frequency-limited temperature}}$ (the temperature of hysteresis is 2), the machine is allowed to start, otherwise it should not be started, and should be stopped to treat according to the overload protection:

Clear the trouble at the mode of power turn-off / heating, and the protection times are not counted.

1. Frequency limited

If $[T_{\text{heating overload frequency-limited temperature}}] \leq T_{\text{inner pipe}} < [T_{\text{heating overload frequency reducing temperature at normal speed}}]$, you should limit the frequency raising of compressor.

2. Reducing frequency at normal speed and stopping machine:

If $T_{\text{heating overload frequency reducing temperature at normal speed}} \leq T_{\text{inner pipe}} < [T_{\text{heating overload frequency reducing temperature at high speed}}]$, you should adjust the compressor frequency by reducing 8Hz/90s till the lower limit; After it was running 90s at the lower limit, if $T_{\text{heating overload frequency reducing temperature at normal speed}} \leq T_{\text{inner pipe}}$, then overload protects machine stopping;

3. Reducing frequency at high speed and power turn-off:

If $[T_{\text{heating overload frequency reducing temperature at high speed}}] \leq T_{\text{inner pipe}} < [T_{\text{heating overload power turn-off temperature}}]$, you should adjust the compressor frequency by reducing 30Hz/90s till the lower limit; After it was running 90s at the lower limit, if $T_{\text{heating overload frequency reducing temperature at normal speed}} \leq T_{\text{outer pipe}}$, then Cooling overload protects machine stopping;

4. Power turn-off:

If the $[T_{\text{heating overload power turn-off temperature}}] \leq T_{\text{inner pipe}}$, then T overload protects machine stopping; If $T_{\text{inner pipe}} T_{\text{heating overload frequency-limited temperature}}$ and the compressor has been stopped working for 3 minutes, the machine should be allowed to operate.

5. If the overload protection power turn-off continuously occurs for six times, it should not be resumed automatically, and you should press the ON/OFF button to resume if the fault keeps on. During the process of running, if the running time of compressor exceeds the t overload protection times zero clearing time, the times of overload protection power turn-off should be cleared to recount. The mode of stopping the machine or transferring to supply air will clear the trouble times immediately (if the trouble can not be resumed, transferring mode will not clear it). Protective function for discharge temperature of compressor

1. Starting estimation:

After the compressor stopped working for 180s, if $T_{\text{Discharge}} < T_{\text{Discharge limited temperature}}$ (the temperature of hysteresis is 2°C), the machine is allowed to start, otherwise it should not be started, and should be stopped to treat according to the discharge temperature:

The machine should be stopped or transferred to supply air, the trouble should be cleared immediately, and the protection times are not counted.

2. Frequency limited

If $[T_{\text{Limited frequency temperature during discharging}}] \leq T_{\text{Discharge}} < [T_{\text{frequency reducing temperature at normal speed during discharging}}]$, you should limit the frequency raising of compressor.

3. Reducing frequency at normal speed and stopping machine:

If $[T_{\text{frequency reducing temperature at normal speed during discharging}}] \leq T_{\text{Discharge}} < [T_{\text{frequency reducing temperature at high speed during discharging}}]$, you should adjust the compressor frequency by reducing 8Hz/90s till the lower limit; After it was running 90s at the lower limit, if $[T_{\text{frequency reducing temperature at normal speed during discharging}}] \leq T_{\text{Discharge}}$, you should discharge to protect machine stopping;

4. Reducing frequency at high speed and power turn-off:

If $[T_{\text{frequency reducing temperature at high speed during discharging}}] \leq T_{\text{Discharge}} < [T_{\text{Stop temperature during discharging}}]$, you should adjust the compressor frequency by reducing 30Hz/90s till the lower limit; After it was running 90s at the lower limit, if $[T_{\text{frequency reducing temperature at normal speed during discharging}}] \leq T_{\text{Discharge}}$, you should discharge to protect machine stopping;

5. Power turn-off:

If the $[T_{\text{Power turn-off temperature during discharging}}] \leq T_{\text{Discharge}}$, you should discharge to protect machine stopping; If $[T_{\text{Discharge}}] < [T_{\text{Limited frequency temperature during discharging}}]$ and the compressor has been stopped for 3 minutes, the machine should be allowed to operate.

6. If the discharging temperature protection of compressor continuously occurs for six times, it should not be resumed automatically, and you should press the ON/OFF button to resume. During the process of running, if the running time of compressor exceeds the t Protection times clearing of discharge, the discharge protection is cleared to recount. Stopped or transferred to supply air mode will clear the trouble times immediately (if the trouble can not be resumed, mode transferring also will not clear it).

7. Frequency limited

If $[I_{\text{Limited frequency when overcurrent}}] \leq I_{\text{AC Electric current}} < [I_{\text{frequency reducing when overcurrent}}]$, you should limit the frequency raising of compressor.

8. Reducing frequency:

If $[I_{\text{Frequency reducing when overcurrent}}] \leq [I_{\text{AC Electric current}} | \text{Power turn-off when overcurrent}]$, you should reduce the compressor frequency till the lower limit or exit the frequency reducing condition;

9. Power turn-off:

If $[I_{\text{Power turn-off machine when overcurrent}}] \leq [I_{\text{AC Electric current}}]$, you should carry out the overcurrent stopping protection; If $I_{\text{AC Electric current}} < [I_{\text{Limited frequency when overcurrent}}]$ and the compressor has been stopped for 3 minutes, the machine should be allowed to operate.

10. If the overcurrent protection continuously occurs for six times, it should not be resumed automatically, and you should press the ON/OFF button to resume. During the process of running, if the running time of compressor exceeds the $[t_{\text{Protection times clearing of over current}}]$, the discharge protection is cleared to recount.

(6)Voltage sag protection

After start the compressor, if the time of DC link Voltage sag [$U_{\text{Sagging protection voltage}}$] is measured to be less than $t_{\text{Voltage sag protection time}}$, the machine should be stop at once, hand on the voltage sag trouble, reboot automatically after 30 minutes.

(7)Communication fault

When you have not received any correct signal from the inner machine in three minutes, the machine will stop for communication fault. When you have not received any correct signal from driver IC (aim to the controller for the separating of main control IC and driver IC), and the machine will stop for communication fault. If the communication is resumed, the machine will be allowed to operate.

(8)Module protection

Testing the module protective signal immediately after started, once the module protective signal is measured, stop the machine with module protection immediately. If the module protection is resumed, the machine will be allowed to operate. If the module protection continuously occurs for three times, it should not be resumed automatically, and you should press the ON/OFF button to resume. If the running time of compressor exceeds the [$t_{\text{Protection times clearing of module}}$], the module protection is cleared to recount.

(9)Module overheating protection

1. Starting estimation:

After the compressor stopped working for 180s, if $T_{\text{Module}} < [T_{\text{Module frequency limited temperature}}]$ (the temperature of hysteresis is 2), the machine is allowed to start, otherwise it should not be started, and should be stopped to treat according to the module overheating protection: The machine should be stopped or transferred to supply air, the trouble should be cleared immediately, and the protection times are not counted.

2. Frequency limited

If $[T_{\text{Limited frequency temperature of module}}] \leq T_{\text{Module}} < [T_{\text{frequency reducing temperature at normal speed of module}}]$, you should limit the frequency raising of compressor.

3. Reducing frequency at normal speed and power turn-off:

If $[T_{\text{frequency reducing temperature at normal speed of module}}] \leq T_{\text{Module}} < [T_{\text{frequency reducing temperature at high speed of module}}]$, you should adjust the compressor frequency by reducing 8Hz/90s till the lower limit; After it was running 90s at the lower limit, if $[T_{\text{frequency reducing temperature at normal speed of module}}] \leq T_{\text{Module}}$, you should stop the machine for module overheating protection;

4. Reducing frequency at high speed and power turn-off:

If $[T_{\text{frequency reducing temperature at high speed of module}}] \leq T_{\text{Module}} < [T_{\text{Power turn-off temperature of module}}]$ you should adjust the compressor frequency by reducing 30Hz/90s till the lower limit; After it was running 90s at the lower limit, if $[T_{\text{frequency reducing temperature at normal speed of module}}] \leq T_{\text{Module}}$, you should stop the machine for module overheating protection;

5. Power turn-off:

If the $[T_{\text{Power turn-off temperature of module}}] \leq T_{\text{Module}}$, you should stop the machine for module overheating protection; If $T_{\text{Module}} < [T_{\text{Limited frequency temperature of module}}]$ and the compressor has been stopped for 3 minutes, the machine should be allowed to operate.

6. If protection continuously occurs for six times, it should not be resumed automatically, and you should press the ON/OFF button to resume. During the process of running, if the running time of compressor exceeds the [$t_{\text{Protection times clearing of module}}$], the discharge protection is cleared to recount. Stopped or transferred to supply air mode will clear the trouble times immediately (if the trouble can not be resumed, mode transferring also will not clear it).

(10)Compressor overloads protection

If you measure the compressor overload switch action in 3s, the compressor should be stopped for overloading. The machine should be allowed to operate after overload protection was measured to resume. If the overloading protection continuously occurs for three times, it should not be resumed automatically, and you should press the ON/OFF button to resume. The protection times of compressor is allowed to clear after the compressor run [$t_{\text{Protection times clearing of compressor overloading}}$] 30 minutes.

(11)Phase current overcurrent protection of compressor

During the running process of compressor, you could measure the phase current of the compressor, and control it according to the following steps:

1. Frequency limited

$[I_{\text{Limited frequency phase current}}] \leq [I_{\text{Phase current T frequency reducing phase current}}]$, you should limit the frequency raising of $[I_{\text{Phase current T frequency reducing phase current}}]$

2. Reducing Frequency

If $[I_{\text{Frequency Reducing Phase Current}}] \leq I_{\text{Phase Current}} < [I_{\text{Power Turn-Off Phase Current}}]$, the compressor shall continue to reduce frequency till the lowest frequency limit or out of the condition of reducing frequency;

3. Power turn-off

If $[I_{\text{Phase Current}}] \geq [I_{\text{Power Turn-Off Phase Current}}]$, the compressor phase current shall stop working for overcurrent protection; if $[I_{\text{Phase Current}}] \leq [I_{\text{Frequency Reducing Phase Current}}]$, and the compressor have stopped working for 3 min, the machine shall be allowed to operate;

4. If the overcurrent protection of compressor phase current continuously occurs for six times, it should not be resumed automatically, and you should press the ON/OFF button to resume. During the process of running, if the running time of compressor exceeds the [$t_{\text{Clearing Time of Compressor Phase Current Times}}$], the overcurrent protection is cleared to recount.

Clearing Time of



(12) Starting-up Failure Protection for Compressor

Stop the compressor after its starting-up fails, restart it after 20s if the fault doesn't show, and if they are all failing for the successive start 3 times, it shall be reported as Starting-up Failure, and then restart up it after 3 min. When it still not be able to operate through carry out the above process for 5 times, it is available if press ON/OFF. And the compressor should be cleared the times after it run 2 min.

(13) Out-of-Step Protection for Compressor

The out-of-step protection signal should be detected immediately after starting-up compressor, and once find the out-of-step protection signal, the out-of-step protection shall be stopped; if it can run for lasting power turn-off 3 min, the machine shall be allowed to operate. If it still can't run automatically when the out-of-step protection for compressor happens to stop working for 6 times in succession, it needs to press ON/OFF to operate. And if the running time is more than 10 min, the power turn-off times for out-of-step protection shall be cleared and recounted.

(14) Voltage Abnormity Protection for DC Bus

To detect voltage abnormity protection for dc bus after completing the pre-charge:

1.Over-High Voltage Protection for DC Bus:

If it found the DCbus voltage $U_{DC} > [U_{DC} \text{ Jiekuangchun Protection}]$, turn off PFC and stop the compressor at once, and it shall show the DC over-high voltage failure; it should clear out the failure when the voltage dropped to $U_{DC} < [U_{DC} \text{ Jiekuangchun Recovery}]$ and the compressor stopped for 3 min.

2.Over-Low Voltage Protection for DC Bus:

If it found the DC bus voltage $U_{DC} < [U_{DC} \text{ Wantuochun Protection}]$, turn off PFC and stop the compressor at once, and it shall show the DC over-low voltage; and it should clear out the failure when the voltage raised to $U_{DC} > [U_{DC} \text{ Wantuochun Recovery}]$ and the compressor stopped for 3 min.

3.To detect voltage abnormity protect for DC bus when getting electricity:

If it found the DC bus voltage $U_{DC} > [U_{DC} \text{—Over-High Voltage}]$, turn off the relay at once, and shows voltage abnormity failure for DC Bus. And the failure can't recover except to break off and get the electricity.

(15)Abnormity Protection for Four-way Valve

Under the model of heating operation in good condition: the compressor is detected $[T_{\text{Inner Tube}} < (T_{\text{Inner Ring}} - T_{\text{Abnormity Temperature Difference For Four-Way Valve Reversion}})]$, during the running, it should be regarded as four-way valve reversion abnormity. And then it can run if stop the reversion abnormity protection for four-way valve 3 min; and if it still can't run when the reversion abnormity protection for four-way valve happens to stop working for 3 times in succession, it is available if presses ON/OFF.

Attention: the protection shall be shielded during the testing mode and defrosting process, and it shall be cleared out the failure and its times immediately when turning off or delivering wind / cooling / dehumidifying mode conversed (the inverted mode don't clear out the failure when it can't recover to operate).

(16) PFC Protection

1. After start up the PFC, it should detect the protection signal of PFC immediately; under the condition of PFC protection, it should turn off the PFC and compressor at one time;
2. It shows the failure is cleared out if PFC Protection stopped working 3 min and recovers to run automatically;
3. If it still can't run when it occurs PFC protection for 3 times in succession, it is available if presses ON/OFF; and clear the PFC Protection times when start up PFC for 10min.

(17) Failure Detection for Sensor

1. Outdoor Ambient Sensor: detect the failure of sensor at all times.
2. Outdoor Tube Sensor: You should not detect the failure of outdoor tube sensor within 10 minutes heating operation compressor except the defrosting, and you could detect it at other time.
3. Outdoor Exhaust Sensor:
 - (a) The compressor only detect the sensor failure after it start up 3 min in normal mode;
 - (b) It should detect the exhaust sensor failure immediately in the testing mode.
4. Module Temperature Sensor:
 - (a) Short-Circuit Detection: the compressor should be detected immediately when the module temperature sensor occurs short-circuits;
 - (b) Open-Circuit Detection: the compressor should be detected on open-circuit when it runs 3min (it needn't 30s avoiding the module over-heated).
 - (c) Detect the sensor failure at all times in the testing mode.
5. Disposal for Sensor Protection
 - (1) When the short-circuit of sensor is detected within 30s, It is regarded as the temperature of sensor over-high (or infinitely high), and now according to the over-high sensor, the machine should carry out the corresponding protection to stop working, and show the corresponding temperature shutdown protection and sensor failure at the same time (for example: the compressor stops immediately when the outdoor tube sensor short-circuit, and the machine shall show the overload protection and outdoor tube sensor failure).
 - (2) When the open-circuit of sensor is detected within 30s, The protection shall be stopped and it shall show the corresponding sensor failure.

6. Electric Heating Function of Chassis

- (1) When $T_{\text{outdoor amb.}} \leq 0^{\circ}\text{C}$, the electric heating of chassis will operate;
- (2) When $T_{\text{outdoor amb.}} > 2^{\circ}\text{C}$, the electric heating of chassis will stop operation;
- (3) When $0^{\circ}\text{C} < T_{\text{outdoor amb.}} \leq 2^{\circ}\text{C}$, the electric heating of chassis will keep original status.

7. Electric Heating Function of Compressor

- (1) When $T_{\text{outdoor amb.}} \leq -5^{\circ}\text{C}$, compressor stops operation, while the electric heating of compressor starts operation;
- (2) When $T_{\text{outdoor amb.}} > -2^{\circ}\text{C}$, the electric heating of compressor stops operation;
- (3) When $-5^{\circ}\text{C} < T_{\text{outdoor amb.}} \leq -2^{\circ}\text{C}$, the electric heating of compressor will keep original status.



JF00303117



GREE ELECTRIC APPLIANCES, INC. OF ZHUHAI

Add: West Jinji Rd, Qianshan, Zhuhai, Guangdong, China, 519070
Tel: (+86-756) 8522218
Fax: (+86-756) 8669426
E-mail: gree@gree.com.cn www.gree.com

HONG KONG GREE ELECTRIC APPLIANCES SALES LIMITED

Add: Unit 2612, 26/F., Miramar Tower 132 Nathan Road, TST, Kowloon, HK
Tel: (852) 31658898 Fax: (852) 31651029

For product improvement, specifications and appearance in this manual are subject to change without prior notice.