

LOCKING SCREW
2.0mm [5/64in] HEX
USED TO ACTIVATE 22.5° INDEXING
WHEN TIGHTENED

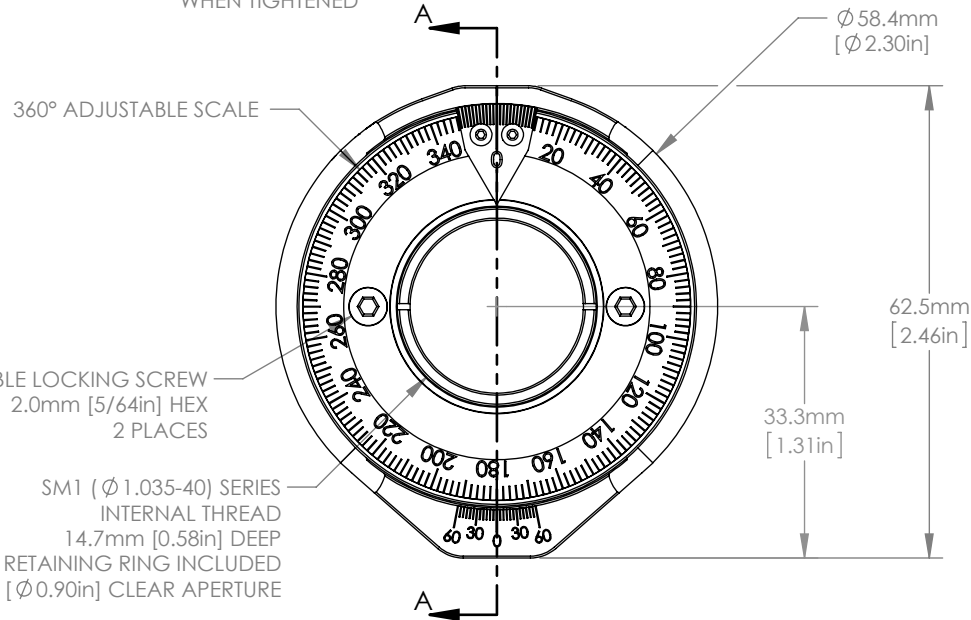

ADJUSTABLE LOCKING SCREW
2.0mm [5/64in] HEX
2 PLACES

SM1 (Ø 1.035-40) SERIES
INTERNAL THREAD
14.7mm [0.58in] DEEP
(1) SM1RR RETAINING RING INCLUDED
Ø 22.9mm [Ø 0.90in] CLEAR APERTURE

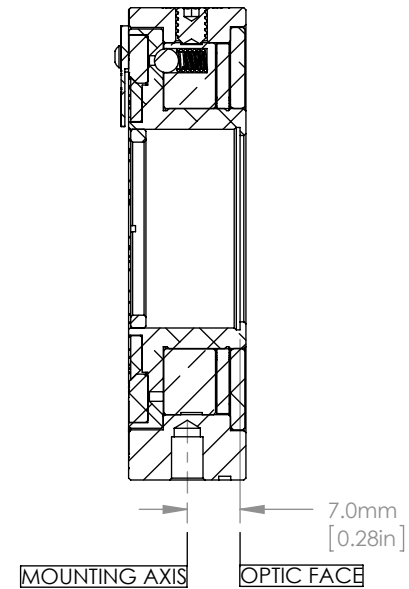
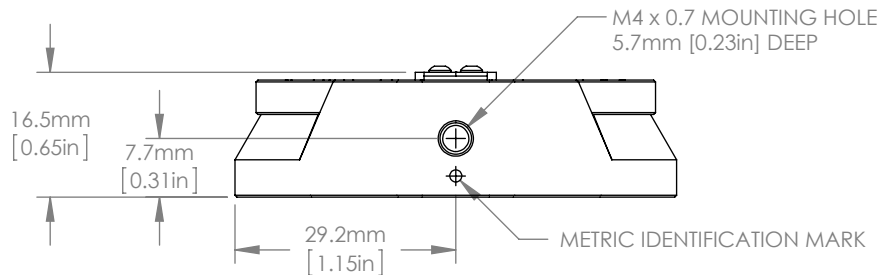

SECTION A-A

FOR INFORMATION ONLY
NOT FOR MANUFACTURING PURPOSES

DRAWING PROJECTION			THORLABS www.thorlabs.com	
NAME	DATE	22.5° METRIC INDEXING MOUNT FOR Ø1in OPTICS		
DRAWN	AK	26/MAY/15	MATERIAL	
APPROVAL	PG	04/JUN/15	N/A	REV B
COPYRIGHT © 2015 BY THORLABS			ITEM #	APPROX WEIGHT
VALUES IN PARENTHESIS ARE CALCULATED AND MAY CONTAIN ROUND-OFF ERRORS			RSP1X225/M	0.11 kg