



Service manual Rev. 1.4

Date issued 13.07.2022
Date of approval 13.07.2022

INDEX

1.	INTRODUCTION.....	3
1.1.	INTRODUCTORY REMARKS	3
1.1.1.	General Aspects.....	3
1.1.2.	Safety Aspects.....	3
1.1.3.	Legal Aspects	3
1.1.4.	Environmental Aspects	3
1.2.	DATA REGISTRATION.....	4
1.2.1.	Equipment and customer registration / Service file	4
1.2.2.	Configuration register.....	4
1.2.3.	Product documentation	4
1.2.4.	Technical modifications	4
1.2.5.	Product evaluation	4
1.2.6.	Additional Information	5
1.2.7.	Installation.....	5
1.3.	GENERAL.....	5
1.3.1.	Technical Data.....	5
1.3.1.1.	Spirolab unit	5
1.3.1.2.	Battery charger.....	6
2.	HARDWARE DESCRIPTION	7
2.1.	MAIN BOARD MODULE	7
2.1.1.	Charging controller for battery (U5 BQ2004)	7
2.1.2.	Room temperature sensor.....	8
2.1.3.	USB communication port.....	8
2.1.4.	Oximetry port.....	9
2.2.	DISPLAY MODULE.....	9
2.3.	PRINTER MODULE	9
2.4.	TURBINE FLOWMETER.....	9
3.	MAINTENANCE	10
3.1.	GENERAL.....	10
3.2.	TEST EQUIPMENT	10
3.3.	CHECKLIST.....	11
3.3.1.	Functional test.....	11
3.3.1.1.	Self test.....	11
3.3.1.2.	Software version	11
4.	REPLACEMENT PROCEDURES	11
4.1.	General	11
4.2.	Cover.....	12
4.2.1.	Opening the device	12
4.3.	PCBs and components	13
4.3.1.	Removing and replacing the display.....	13
4.3.2.	Removing and replacing the battery pack	15
4.3.3.	Removing and replacing the thermal printer.....	16
4.3.4.	Turbine	16
4.3.4.1.	Cleaning the reusable turbine.....	17
4.3.4.2.	Calibration of the reusable turbine.....	17
4.3.5.	Internal software upgrade procedure	17
4.4.	Oximeter module	19
4.4.1.	Replacing of the oximetry module	19
4.5.	Testing procedures	19
4.5.1.	Testing procedures for devices with oximeter.....	19
4.5.2.	Testing procedures for devices without oximeter	23
5.	SPARE PARTS.....	25
5.1.	ORDERING	25
5.2.	DELIVERY.....	25
5.2.1.	Ordering PCB's.....	25
5.2.2.	Warranty claims.....	25
5.3.	RETURN SHIPMENTS	25
6.	TROUBLESHOOTING	26
6.1.	The device does not switch on	26
6.2.	The display remains black.....	26
6.3.	The battery is not working correctly	26
6.4.	The device does not measure spirometry at all	27
6.5.	The device does not measure spirometry correctly	27
6.6.	The device does not measure oximetry at all	27
6.7.	The device does not measure oximetry correctly	27
6.8.	The data communication via USB does not function	27
6.9.	Index of components	28
	APPENDIX A: SPARE PARTS LIST	29
	APPENDIX B: SERVICE INFO'S (Product Change Notes)	30
	APPENDIX C.....	31
	ANNEX.....	34

1. INTRODUCTION

1.1. INTRODUCTORY REMARKS

1.1.1. General Aspects

The spirometers from the product group **MIR080** are marketed under the label **Spirolab**.

This manual has been written for technicians involved in the service of the **Spirolab**. Service can be carried out by the service organization of the manufacturer or by any other technician authorized by MIR S.p.A.

The manufacturer will not be held responsible for the results of maintenance or repairs by unauthorized persons.

1.1.2. Safety Aspects

Safe execution of the procedures in this manual requires technical experience and general knowledge of safety precautions.

 **Before you start any operation on the unit, you must have first read both the User and this Service Manual.**

Warnings, Cautions and Notes are used throughout this manual to bring special matters to the immediate attention of the reader.

 **Warning** The **Warning** concerns danger to the safety of the technician or user.

 **Caution** The **Caution** draws attention to an action which may damage the equipment.

Note The **Note** points out a statement deserving more emphasis than the general text, but which does not deserve a Warning or Caution.

 **Warning**

In order to prevent unforeseen incidents, keep away from sensitive electronic devices. Inside the Spirolab there are low voltages and very low currents, so these represent no danger for persons with experience and with a general knowledge of safety precautions.

The sequence of steps in a procedure may also be important from the point of view of personal safety and prevention of damage, therefore never change the sequence of steps or alter any procedure.

 **Warning**

Batteries may explode if defective or damaged or disposed of in fire. Do not short-circuit the batteries!

1.1.3. Legal Aspects

This manual and the information herein are property of MIR S.p.A. (Rome, Italy).

Copying this manual in whole or in part is strictly forbidden.

MIR S.p.A. disclaims any responsibility for personal injury and/or damage to equipment caused by:

- negligence or disregard of a Warning or Caution
- deviation from any of the prescribed procedures
- execution of activities which are not prescribed
- ignorance of the general safety precautions for handling tools and the use of electricity
- incorrect or unreasonable use

1.1.4. Environmental Aspects

Please dispose properly of any items replaced, following all the local regulations.

All components (housing, PCBs, batteries, electronic and disposable parts, etc.) must be disposed of according to the relevant local regulations.

1.2. DATA REGISTRATION

1.2.1. Equipment and customer registration / Service file

From the point of view of safety and product liability the following data must be registered for each unit:

Equipment data	Model, REF code and serial number
Customer data	date of purchase
	name and full address of the customer
Service data	log of all service activities
Configuration data	the actual configuration of the equipment (hardware and software versions)

The distributor (through their dealer and/or service organization, if any) is responsible for maintaining these records and they must be able to provide these data when requested.

1.2.2. Configuration register

A configuration file gives the serial numbers and/or batch numbers of main sub-assemblies and/or important parts of each unit. The parts listed in a configuration file are defined as registered parts. For example parts as mainboards, display, batteries and internal software.

Note

MIR S.p.A. has the original configuration file of each unit sold. Any possible changes in the original configuration of the supplied units must be filed and the distributor must be able to provide this data.

1.2.3. Product documentation

The documentation set for the **Spirolab** includes a User Manual. The User Manual is a recommended item for all service engineers. The user manual is available in the following languages:

- English
- Spanish
- German
- French
- Italian
- Portuguese

1.2.4. Technical modifications

This publication could include technical inaccuracies or typographical errors. Changes are periodically made to the information herein; these changes will be published as Service Info in appendix B of this Service Manual.

Note

Some functions described in this manual may not be activated in the present software or hardware version. For detailed information, please refer to the User Manual.

1.2.5. Product evaluation

In order continuously to improve the quality of our products, MIR S.p.A. requests that the service organizations should report any device issue which may be discovered. When the same issue regularly occurs or when a safety issue occurs, MIR S.p.A. would like you to send us a product complaint report. The report must contain the name, the type of product, a detailed description of the problem, the frequency of the same problems, the quantity of sold equipment and your solution to the problem (if any).

1.2.6. Additional Information

Please do not hesitate to contact MIR if you require additional information.

Manufacturer's address:

<p>MIR S.p.A. Medical International Research Via del Maggiolino, 125 00155 Rome, Italy Tel.: +39 06 2275 4777 Fax.: +39 06 2275 4785 Email: mir@spirometry.com</p>	<p>MIR USA, Inc. 5462 S. Westridge Drive New Berlin, WI 53151 - USA Tel + 1 (262) 565 – 6797 ; Fax + 1 (262) 364 – 2030 Website: www.spirometry.com ; Email: mirusa@spirometry.com</p>
---	---

1.2.7. Installation



Warning:

Before using Spirolab check internal battery charge level.

- turn the **spirolab** on, press then release the button on the front of the unit.



1.3. GENERAL

Spirolab is an “open circuit system” for the measurement of inspiratory and expiratory lung function parameters and oximetry values, such as pulse rate and SpO2. It is suitable for basic lung function analysis of the mechanical respiratory tract parameters. Three different respiratory tests can be performed:

- the forced vital capacity test (FVC),
- the slow Vital Capacity test (VC/IVC)
- the Maximum Voluntary Ventilation test (MVV)

Spirolab has been designed and manufactured to ensure the highest level of safety and the unit fully complies with the stringent international IEC 60601-1:2005+A1:2012 and IEC 60601-1-2:2015 standards.

1.3.1. Technical Data

1.3.1.1. Spirolab unit

Max. current inside the unit	400 mA (with LCD at the maximum lightness)
Internal batteries	NiMH rechargeable 7.2V battery pack (6 batteries, 1.2V each), 4000 mAh
Approval	CE 0476 EC mark for Medical Devices FDA
Dimensions	Main body 220x210x51 mm;
Weight	Central unit 1450 g (including battery pack)
Volume range	10 L
Flow range	± 16 L/s
Volume accuracy (ATS 2019)	± 2.5% or 50 mL

Flow accuracy	± 5% or 200 mL/s
Dynamic resistance at 12 L/s	< 0,5 cmH ₂ O/L/s
Type of electrical protection	Internally powered Class II while charging battery
Level of protection against direct or indirect contact	Category BF apparatus
Level of water ingress protection	IPX1 device, protected against water drops
Level of assurance of use in the presence of an anaesthetic mix flammable with air or oxygen or protoxide of nitrogen	Apparatus not suitable
Conditions of use	Apparatus for repeated use
Storage conditions	Temperature: MIN -40 °C, MAX +70 °C Humidity: MIN 10% RH; MAX 95%RH Athmospheric pressure: 50kPa, 106 kPa
Transport conditions	Temperature: MIN -40 °C, MAX + 70 °C Humidity: MIN 10% RH; MAX 95%RH Athmospheric pressure: 50kPa, 106 kPa
Operating conditions	Temperature: MIN +10 °C, MAX +40 °C Humidity: MIN 10% RH; MAX 95%RH Athmospheric pressure: 70kPa, 106 kPa

1.3.1.2. Battery charger

Model AC/DC 12W-N1EFM

2. HARDWARE DESCRIPTION

Because of the modular design of the **Spirolab**, the description is on a block diagram level.

BLOCK DIAGRAM

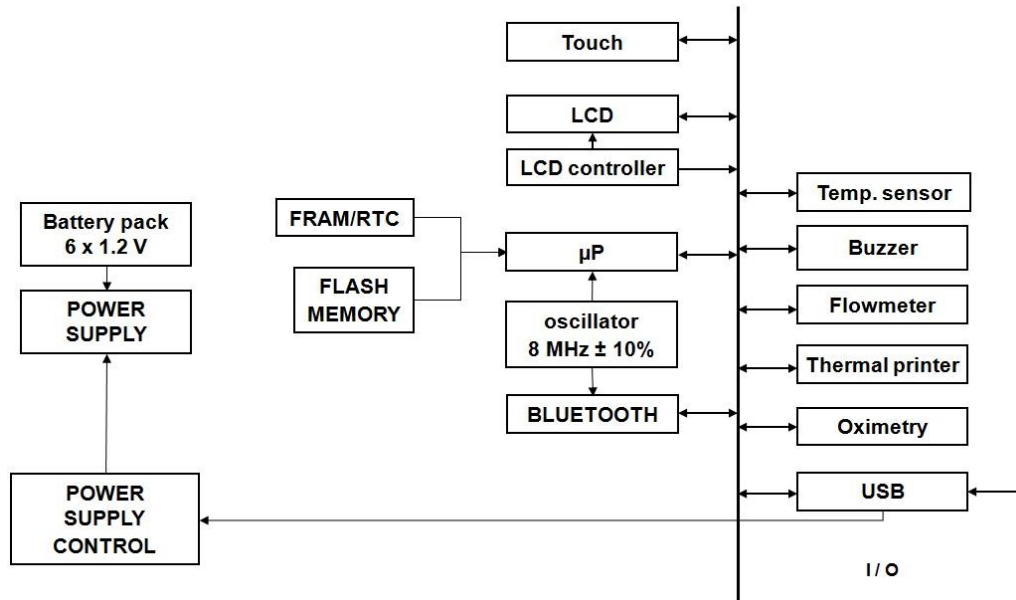

2.1. MAIN BOARD MODULE

The main board module translates the input signal from the turbine flowmeter into spirometry values and compares them with the predicted values calculated with the parameters age, sex, height, weight and ethnic group. Test results are displayed on a LCD and can be printed on paper with an external printer. Spirometry test data are stored into memory and are available for later use.

The main board module also makes a calculation using the oximetry input signal; from this signal collected at a 16 msec/frequency the percentage value of oxygen saturation in the blood and the heart beat values are obtained, which are oximetry parameters.

The main board module includes:

- Main Microcontroller
- FLASH memory with device configuration and spirometry data
- FRAM/RTC with non volatile memory and real time clock
- Measuring controller for flow, volume and ambient temperature
- Ambient temperature sensor (to enable conversion from ATP to BTPS conditions).
- USB port
- Oximetry port
- Bluetooth module

2.1.1. Charging controller for battery (U5 BQ2004)

The charging controlling circuit used in the **Spirolab** ensures a charge and optimum condition of the battery providing that the battery temperature and voltage are within the preset limits. Temperature, voltage and time are all monitored throughout the charge process.

The charging process itself is automatically initiated in two situations:

1. After connecting the battery charger to the unit.
2. When the unit is switched on, the battery charger is connected and the voltage level of the battery is below a preset limit. In this situation the LCD indicates the low battery status with one line in the battery indicator.

The fast charging process is terminated by any of the following:

- Battery voltage out of range (Maximum/Minimum)
- Battery temperature out of range (Maximum/Minimum)
- Maximum charging time (timeout = 5h:30min)
- Termination according to the charging mode, chosen by jumper JP2.

Charging termination modes:

1. Temperature Arise Detection ($\Delta T/\Delta t$), JP1 jumper in the default position. The battery temperature increases more quickly when the battery is fully charged. If the speed of temperature increase inside the battery pack exceeds a certain value then the charging process is terminated. The charging controller (U5) samples the thermistor voltage (NTC) every 34 sec., and compares it to the value measured two samples earlier. If the voltage has fallen $16\text{mV} \pm 4\text{mV}$ or more, the fast charge is terminated.
2. Peak Voltage Detection (PVD), JP1 jumper in the other possible position: The battery's voltage decreases slightly when it is fully charged. In this charging-mode, the microcontroller checks the battery voltage and terminates the charging process in the event that the voltage on the battery pack decreases by more than the preset limit, that limit is configured by the position of the jumper: In this mode, the battery's voltage is the criteria for terminating the charging process. If the voltage decreases by $36\text{mV} \pm 4\text{mV}$ in 34 seconds this means that the battery is fully charged, and the controller then terminates the charging process.
3. Decrease Voltage Detection ($-\Delta V$), no JP8 jumper. This mode is correspondent to the PVD-mode, but at higher sensibility, because the charging process ends at a voltage decrease of $18\text{mV} \pm 2\text{mV}$ in 34 seconds.



Caution

In case high power while charging is required (i.e. when printing), the battery's voltage decreases. In this case using the modes Peak voltage Detection or $-\Delta V$ the charging process will be terminated, although the battery is not fully charged.

The factory setting is designed for the $\Delta T/\Delta t$ Termination mode and is not to be changed to avoid the above-mentioned problems!

Charging phases:

1. After connecting the battery charger to the unit, the CHARGE_LED starts flashing for few seconds. In this period, the battery is charged in pulses at a low frequency and the battery's response is monitored. If the LED continues to flash this shows that the battery's temperature is out of range or the battery voltage is too low. In this case, the controller enters the charge pending state and waits for both conditions to fall (temperature) or rise (voltage) within their allowed limits. There is no time limit on the charge pending state; the charger remains in this state for as long as the voltage or temperature conditions are outside of the allowed limits. If the voltage is too high, the controller goes to the battery absent state and waits until a new charge cycle is started.
2. If everything is in order (battery temperature, temperature rising, battery voltage etc.) then the fast charging process starts, the LED lights continuously. In the following 10 minutes, the battery is charged at a lower rate to initialize slowly the chemical reaction inside the battery pack. After about 10 minutes, high-frequent pulses at the full current rate of 1A charge the battery.
3. At the end of the regular charging process, the CHARGE_LED lights green continuously. Now it can be assumed that the battery is fully charged.
4. If after completing the charging process the battery charger is still connected, a so-called Pulse-Trickle-Function is activated that gives a very low charge to compensate the self-discharging of the battery while it is idle connected to the charger.

2.1.2. Room temperature sensor

(IC7) DALLAS DS 18B20 to measure the ambient (room) temperature to enable the calculation of the BTPS conversion factor.

2.1.3. USB communication port

Version 2.0.

2.1.4. Oximetry port

Many sensors can be used on **Spirolab** based on the type of test to be performed and on the patient characteristics. The manufacturer provides the most frequently used sensor with the device, which has the following features:

mechanical part	finger
electrical part	two light emitting diodes (LEDs), one emits in the visible spectre and one infrared

Both lights then pass through the finger and are “read” by the receiver. As these lights pass through the finger, a proportion of the light is absorbed by the blood and by the soft tissue, in function of the concentration of haemoglobin. The quantity of light absorbed, at each frequency, depends on the degree of oxygenation of the haemoglobin inside the soft tissue.

2.2. DISPLAY MODULE

The display module shows patient data, user set parameters and test results.. It is connected with:

- 40-pin flat-cable for digital connection (code 512584)
- The back light controller (U20) TPS61166

2.3. PRINTER MODULE

The printer module gives a printout of the patient data and spirometric/oxymetric results. The printer is a thermal printer and requires thermal printing paper.

The printer is connected to the mainboard via 3 cables:

- a 4-pin flat-cable for driving the motor for paper advance
- a 4-pin flat-cable for the sensor, that checks that paper is inserted
- 22-pin flat-cable for supply, data transmission and checking the temperature of the printer head, to avoid overheating.

2.4. TURBINE FLOWMETER

The sensor for measuring flow and volume is similar to the model already used in other spirometers produced by MIR (Series MIR 040 Mod. **Spirodoc**, MIR024_REV2 Mod. **Spirobank G USB**, etc).

The turbine flowmeter consists of one mechanical and two electrical parts:

Mechanical parts:

- turbine

Electrical parts:

- Two pairs of infrared transmitters/receivers positioned as shown below.
- A signal conditioning circuit to rectify the output signal from the two infrared light receivers.

The rotation of the rotor causes the interruption of the infrared beam, thus creating a pulse signal which has a frequency directly proportional to the flow.

The measurement of the air flow which passes through the tube is therefore proportional to the number of interruptions of the infrared beam.

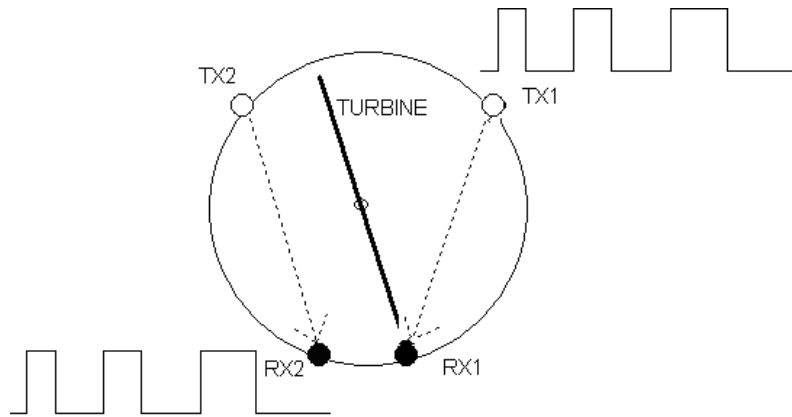

The phase difference $\Delta\phi$ (positive or negative) between the signals from each of the two infrared receivers (RX1 and RX2) depends upon the direction of rotation of the moving rotor and therefore supply the information of the direction of the air flow (expiration or inspiration). In detail, $\Delta\phi > 0$ for expiratory flow, $\Delta\phi < 0$ for inspiratory flow.

The two pulse trains are squared by a Schmitt trigger (LMV932MM on MiniFlowmeter) and then sent to two input ports of the microprocessor (IC17 CP3BT26, pins 38 and 36).

The main microprocessor has the possibility to switch all the peripheral ports on or off, including the turbine.

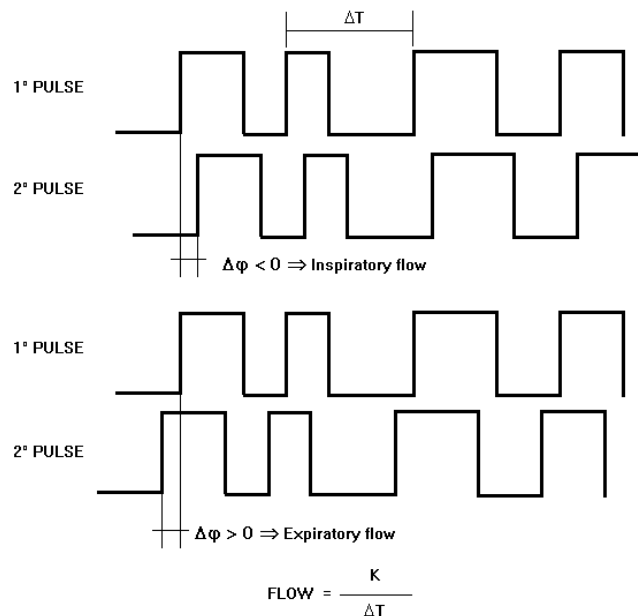

3. MAINTENANCE

3.1. GENERAL

We recommend checking the **Spirolab** on an annual basis.

For cleaning of the **Spirolab** and the accessories please see the User Manual.

3.2. TEST EQUIPMENT

For the repair and maintenance procedures of the **Spirolab** the following test equipment and accessories are required:

- Complete set of precision engineering tools (including 2.5 mm allen key and cross-screwdriver)
- Calibration syringe (3L is recommended)
- Digital multimeter, at least 3½ digits, accuracy better than 1%.
- Oscilloscope
- Digital Thermometer
- PC
- winspiroPRO Software Installation CD
- USB port connection cable
- Oximeter sensor (MIR code 919024)
- Hot Glue Gun
- 3 mm double-sided adhesive tape
- Welder

If a problem cannot be solved with the present equipment and suitable instruments are not available, please send the **Spirolab** to the manufacturer to carry out the service.

3.3. CHECKLIST

The following procedures must be carried out during an inspection and/or after every repair:

- Modifications, if any, must be noted on the “Service Info” sheets. See Appendix B of this manual for further information.
- Visual inspection. Check the electrical connection for safety and check that all components are properly fastened.
- Check that all accessories do not present any visible damage.
- Functional test (see Paragraph 3.3.1)
- File a copy of all service activities.

3.3.1. Functional test

3.3.1.1. Self test

Switch on the equipment. **Spirolab** will carry out the so-called self-test for approx 3 seconds. It is assumed that when the self-test is passed all functions of **Spirolab** are okay.

Any severe malfunction (if any) will be reported on the display.

Switch off **Spirolab**.

3.3.1.2. Software version

To check the software version installed on the device, switch on **Spirolab** pressing and releasing the ON/OFF key, wait for the first screen to appear; the software version is found as indicated in the image alongside.

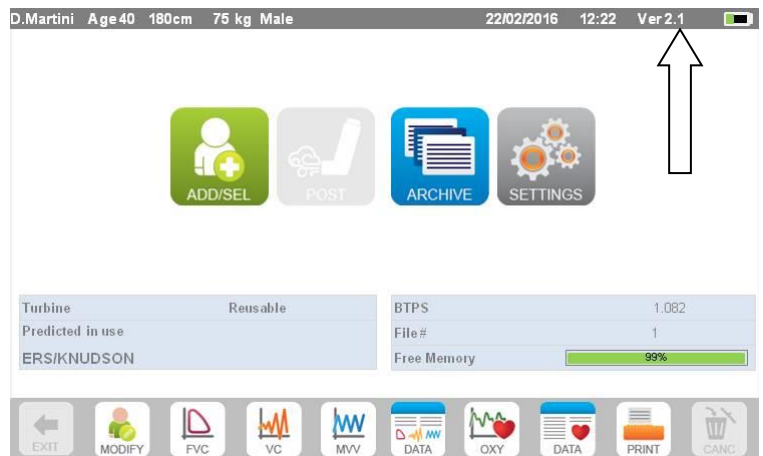

4. REPLACEMENT PROCEDURES

4.1. General

When handling sensitive static devices such as the main board of the **Spirolab** the following precautions should be observed:

- Persons should be earthed by means of a wrist strap.
- Ground all electrical equipment, workbench etc.

Also make sure that you have not left any tools inside and all screws including their washers are again fixed in the original place.

Note

Where not otherwise indicated, the reinstallation of a part is in reverse order of the removal procedure.









After every repair a functional test must be performed.

⚠ Caution

If any soldering (especially on SMD-parts) is to be made, make sure that your tools are suitable for such precision work.

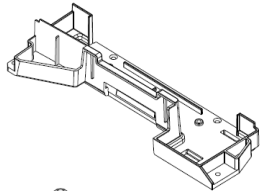
4.2. Cover

The **Spirolab** case consists of several parts as illustrated in the image beside. The display is housed inside its casing which is made up of two parts held together with three screws.

 Code 300600	 Code 300601	MIR004_002  211 x 239 x 38mm Code 300622	MIR004_003  241 x 212 x 37mm Code 300623	 Code 300629
 Code 300604	MIR004_004  242 x 212 x 32mm Code 300624	MIR004_005  13 x 13 x 4mm Code 300608	MIR004_006  65 x 9.5 x 8.5mm Code 300607	

4.2.1. Opening the device

To open Spirolab:

Switch off the device Place the device on a flat surface with bottom part face-up.

Unscrew the screws in the holes highlighted in the image alongside.

Turn upside down the device and remove the thermal paper cover sliding it to the back of the device.

Remove the upper case from the central case starting from the back side; put the nails between the two cases and remove gently the upper case.

Pay attention to the display cables which are connected to the main board

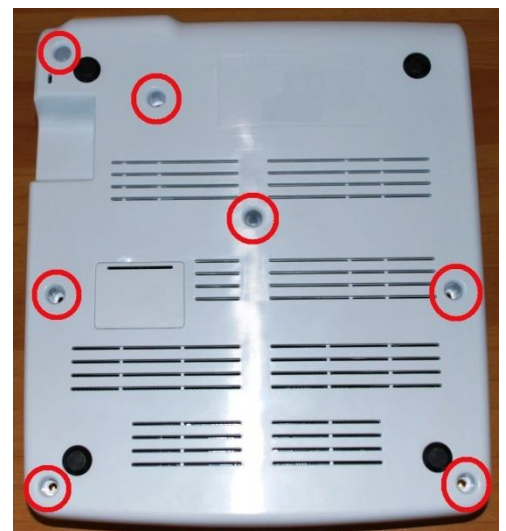

Remove the cable red and white as in the image alongside.
Now it is possible to open some more the upper case and the other two cables will be visible.

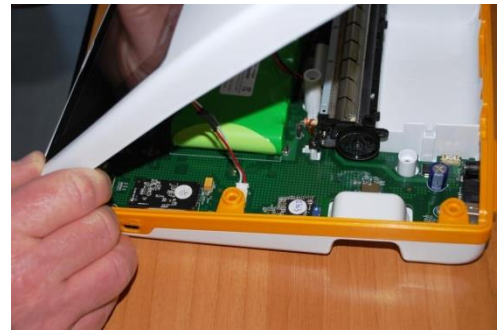

Open the white flat cable connector and the flat will exit easily.
At the end remove the other flat opening the brown connector.
In this way the upper case with the display are completely removed.

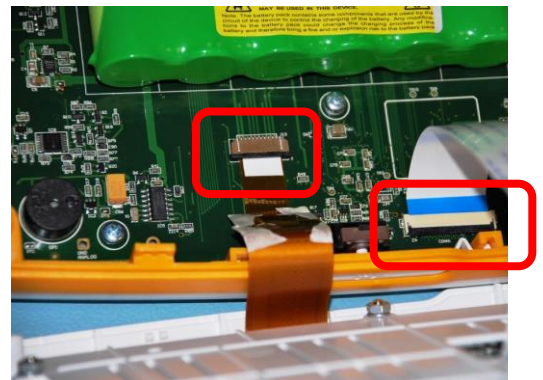

Remove the middle case from the lower case: it is necessary to remove the screw in the upper left corner of the middle case.

4.3. PCBs and components

4.3.1. Removing and replacing the display

Open **Spirolab** as described in Paragraph 4.2.1; remove the damaged display from the upper casing. First of all remove the white flat cable from the connector on the rear side of the display (see image), then remove the nuts and the washers from the upper case.

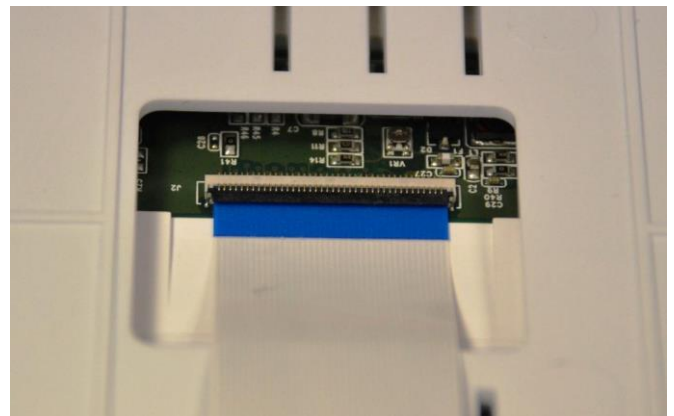

Now the damaged display can be removed from the case.
Apply a new one paying attention to insert the red and white cable in the hole.
Apply the nuts and the washers to the screws
Check if the display is aligned with the housing and then close firmly the nuts.

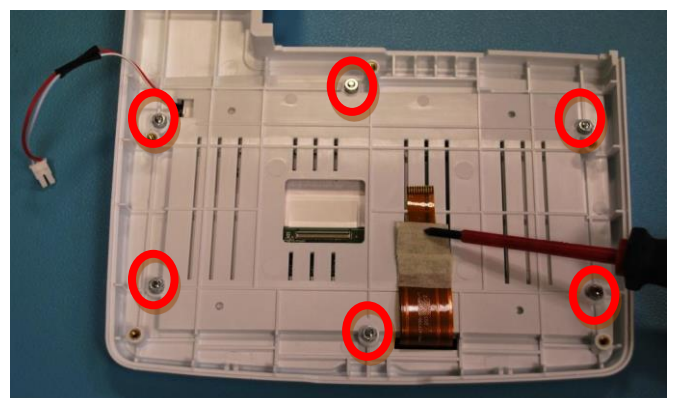

Insert the white flat in the connector and make sure that the black part of the connector is firmly closed above the flat. Apply a bit of hot glue to the connector to block the opening of it.

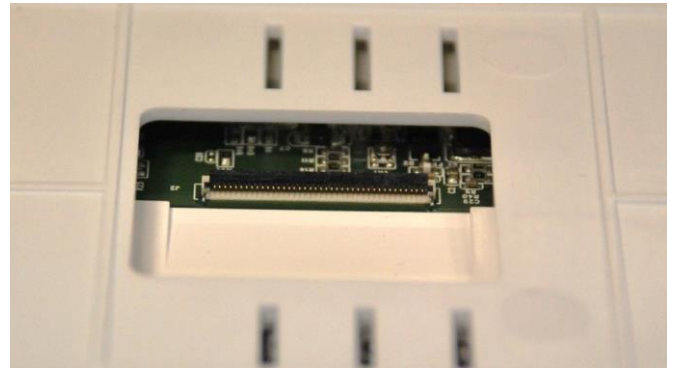

Apply a thick adhesive on the brown flat as in the image below. It has the function to improve the seal when it is inserted in the connector. Connect the two flat cables of the display to the PCB.

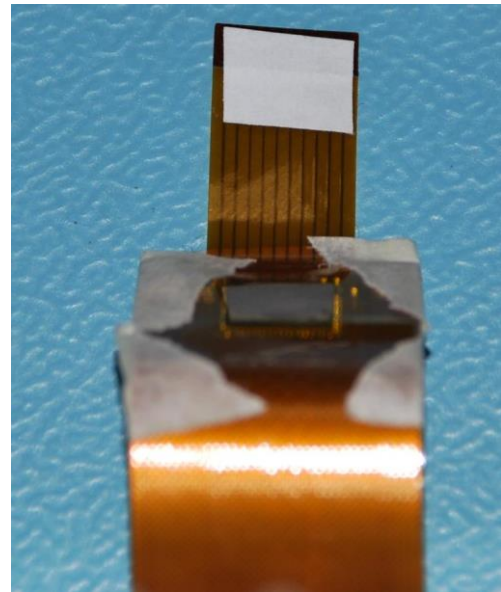

At this time it is possible to close the device following the instruction described in point 4.2.1 in reverse order.



Warning

Devices with serial number in the range: A23-0J.08971 - A23-0J.10970 can show issue to the display such as display screen appears rotated or mirrored.

Open New-Spirolab as shown on Service Manual.

Locate the PCB zone between micro-USB connector and battery

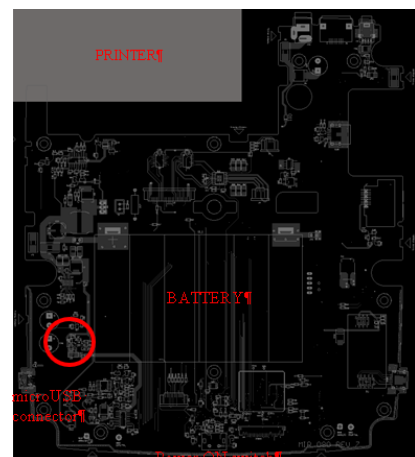

Replace C12 and C12_b

code: 832150_0603 = Capacitor CER SMD 0603 16V/25V X7R/X5R 1u

with

code: 831732_0603 = Capacitor SMD 0603 1nF 5% 25V COG

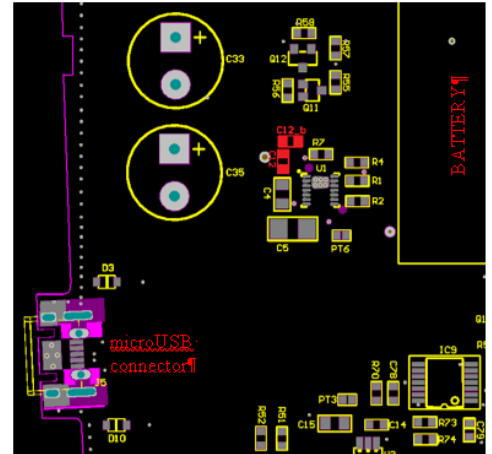

4.3.2. Removing and replacing the battery pack

Open **Spirolab** as described in Paragraph 4.2.1.

To correctly replace the battery pack completely remove the PCB from the lower casing.

Open jumper JP1.

Unsolder the two connectors from the PCB on both sides.

Cut the plastic casing of the battery pack in order to remove the battery elements. In this way it will be more simple to remove the double sided tape which allows to keep firmly the battery pack to the main board.

Replace the battery with a new one.

Apply the double sided tape as in the image alongside.

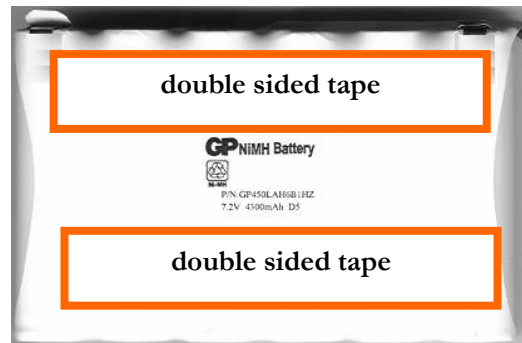

Insert the positive and then the negative pole in their proper place on the PCB. Place the battery pack so that the adhesive tape is towards the PCB and press to firmly seal it to the PCB.

For a better hold it is recommended to also solder the other side of the PCB in order to provide more protection in case of dropping or vibrations.

Caution

Insert the connector in the correct position all the way to the stop. Do not force the connector. Place the cable of the battery bended as shown in the image above; the cable must be blocked between the battery and the lower casing.

Warning

Handle battery pack with care. Contact between battery poles with the circuit board can cause permanent damage to the circuit board itself. During soldering operations avoid any contact whatsoever between battery poles and components of the circuit board.

Before to close the device keep in mind to close the jumper JP1.

Close the device as described in point 4.2.1.

Note

Batteries must be disposed of properly, according to the local regulations.

4.3.3. Removing and replacing the thermal printer

Disconnect the printer by unscrewing the four screws as highlighted in the image.

Disconnect the connectors underneath, paying attention to not pull the flat cable without having first opened the clips

Pay attention to the type of screws because they are different:

- the 2 burnished self-tapping screws 2.2x9.5 (code MIR 340281) in the most external positions as shown in the photo
- the 2 countersunk screws K2.2x8 (code MIR 340279) in the 2 innermost positions adjacent to the paper compartment

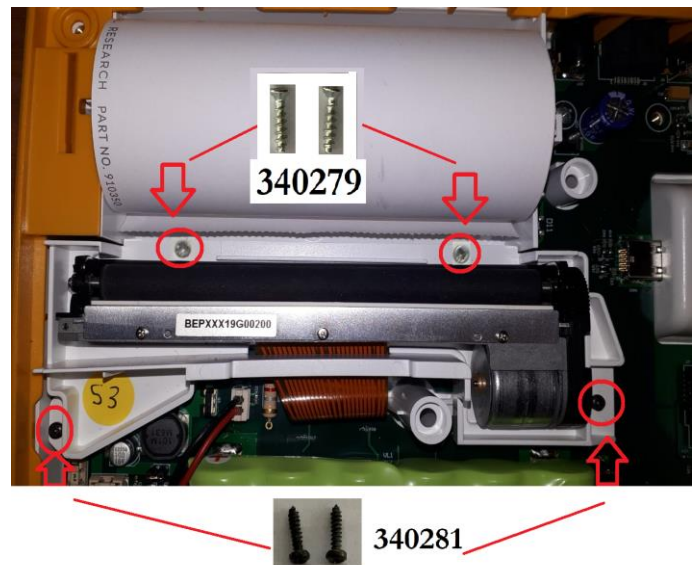

⚠ Caution

While applying the self-tapping screws, pay attention to the position of the flat cables underneath: make sure they are precisely and correctly positioned.

4.3.4. Turbine

There are two types of flow and volume measurement sensors used on **Spirolab**, single-patient disposable and reusable.

Note

The Spirolab turbine measurement system is calibrated in the factory and does not require any adjustments or calibrations.

⚡ Warning



Disposable Turbine

If you are going to perform the spirometry test with a “single-patient” disposable turbine it is important to use a new turbine for every new patient. The characteristics, accuracy and the hygiene of the disposable turbine can only be guaranteed if it has been conserved beforehand in its original sealed packaging. The disposable turbine is made of plastic and its disposal after use should adhere to the local authority guidelines / norms.



Reusable Turbine

The correct functioning of the re-usable turbine can only be guaranteed if it has been cleaned in the correct manner and is free from foreign bodies which could alter its movement. If the turbine has not been cleaned sufficiently this could cause cross contamination from one patient to another. Periodic cleaning should only be done when the instrument is for personal use and will only be used by one patient. The cleaning of the turbine should be done following the guidelines in the User’s Manual.

The following information applies to both turbine models.

Do not expose the turbine to a direct jet of water or air, and avoid contact with high temperature liquids.

Do not allow dust or foreign bodies to enter the turbine sensor, in order to avoid incorrect functioning and possible damage.

The presence of any impurities (such as hair, sputum, threads etc.) within the body of the turbine sensor may seriously compromise the accuracy of the measurements.

The turbines ensure high precision in measurements and have the great advantage of requiring no periodic calibration. In order to maintain the characteristics of the turbine a simple cleaning is required prior to each use (**only for the reusable turbine**). This operation will also guarantee perfect hygiene and the highest possible safety conditions for the patients. Cleaning of the disposable turbine is not required, as it is supplied clean in a sealed plastic bag. It must be disposed of after use.

4.3.4.1. Cleaning the reusable turbine

Cleaning of the disposable turbine is not required, as it is supplied clean in a sealed plastic bag. It must be disposed of after use.

Turbine operation check:

- Turn on **SPIROLAB** and setup the device to perform a spirometry test (for example **FVC**).
- Hold the **SPIROLAB** with one hand and move it slowly sideways, having the air pass through the turbine.
- If the rotor spins properly the device will emit a series of acoustic signals “beeps”. The beeping frequency is a function of the air flow passing through the turbine.
- If no beeps are heard while moving the device, proceed to clean the turbine

CAUTION

Periodically check the inside of the turbine to ensure that there are no impurities, corpuscles, or any foreign matter like hairs which could inadvertently block or even slow down the mobile equipment in the turbine and as a consequence compromise spirometry measurement accuracy.

To clean the **reusable** turbine, first remove it by pulling it gently from the **Spirolab** turning it anti-clockwise and pressing lightly. It can be helpful to push it gently from underneath with one finger from the bottom of the turbine to lift it out of its housing.

Immerse the turbine in a cold liquid solution and move it within the liquid to remove any impurities which may be deposited inside. Leave the turbine immersed for the time specified in the instruction of the solution.

Rinse the turbine by immersing it in clean water (**not hot**).

Shake off the excess water from the turbine and leave it to dry, standing it vertically on a dry surface.

To ensure that the turbine is functioning correctly before replacing it inside the instrument, it is good practice to make a visual check of the rotation blade. Placing the turbine tube horizontally and moving it gently from left to right and vice versa, the rotation blade (rotor) must rotate freely. Otherwise, accurate measurement is no longer guaranteed and the turbine must be replaced.

Once the turbine has been cleaned insert the turbine tube in its place following the instructions indicated by the closed lock symbol printed on the plastic casing of the **Spirolab**.

To insert the turbine correctly push it and then turn it clockwise until it reaches the stop, which ensures that the tube has been blocked inside the casing.

4.3.4.2. Calibration of the reusable turbine

See instructions in the Calibration section of the User Manual of the device.

The turbines used on **Spirolab** do not require periodic calibration as they are already calibrated.

4.3.5. Internal software upgrade procedure

In order to upgrade the software winspiroPRO must already be installed and the PC must have an internet connection for downloading the upgrades and firmware of the **Spirolab** from www.spirometry.com.

Launch winspiroPRO on the PC and connect **Spirolab** to the PC using the USB cable.

winspiroPRO can check the correct functioning of the USB port from the “options” menu; before downloading any newer releases make sure that the device is correctly connected to the PC software, the software will automatically recognize the device if it has already been connected to the PC and then carry out the following instructions. To check the connection between the device and the PC, check the correct functioning from the “options, communication” menu. On the display of **Spirolab** appears the following message:

External control



To download the new internal software version click on "Tools" menu, and then on "Upgrade Device Internal Software"

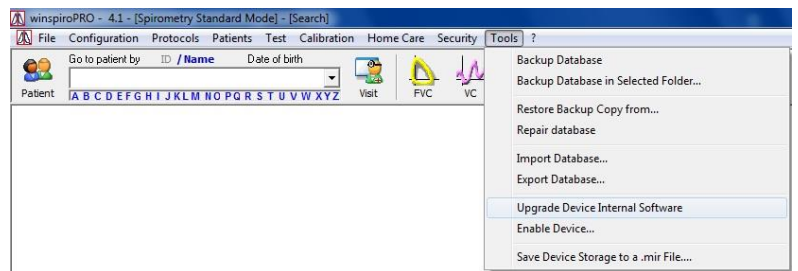

This wizard helps the user to select the method used to connect the device to the PC and then, with the “TEST” icon, the user can check the connection (see image).



Search for the .tsk file to be downloaded into the spirometer. Choose either auto-install or manual file search; browse system resources through list of folders, select .tsk file and then click on Next.



From the “Select file .tsk” search window select the firmware of your device; click on the **Spirolab** folder and then on the selected file to automatically launch the upgrading procedure of the internal software of the spirometer.

4.4. Oximeter module

Due to the design features of the oximeter module inside the device, any technical intervention on the oximetry module will be performed directly MIR.

CAUTION

Make sure before operating on the oximetry module to switch off the device or disconnect the battery pack.

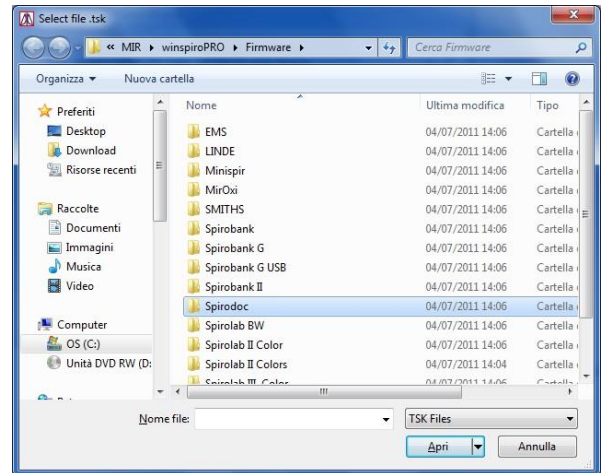

4.4.1. Replacing of the oximetry module

Open the device as described in point 4.2.1. The visible face of the PCB shows near the micro USB connector the housing of the oximetry module. Remove the oximetry module using the hands.

CAUTION

The module is fixed to the PCB so move gently until the module is completely removed.

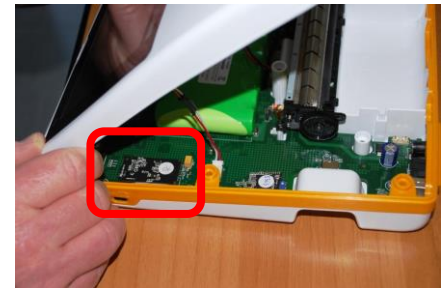

Replace the oximetry module.

To attach the oximetry module to the PCB, it is recommended to apply an adhesive in the space between the PCB and the highest micro on the oximetry module (placed in the face not visible).

Close the device as in point 4.2.1 in reverse order.

4.5. Testing procedures

After making all repairs described in the previous paragraphs, correct functioning tests must be performed on both the Hardware and Software.

Devices with oximeter and devices without oximeter have their own specific testing procedures.

4.5.1. Testing procedures for devices with oximeter

The following checks must be carried out on each device:

Table 1

TESTS ON PCB MIR080 WITH OXIMETER

Test	Procedure	Test method	Instrument	Expected result
Check battery pack application	there should be applied the double sided tape on the battery pack	Visual	\	The doubled sided adhesives must be applied between the PCB and the battery pack
Block of PCB on the lower case	There should be applied 11 screws and washers in the special holes	Visual	\	The screws should be all correctly screwed
Display application on the upper case	There should be applied 6 nuts and showers between display and case	Visual	\	The nuts should be all correctly screwed
White flat display application to the display	There should be applied and blocked with hot glue	Visual	\	Presence of hot glue on the connector
Brown flat display application	There should be applied a thick adhesive to the flat	Visual	\	Presence of a thick adhesive on the flat
Blocking of display flats	Application of thick adhesive on connectors J13 and CONN1	Visual	\	Presence of a thick adhesive on the two connectors
Blocking of oximetry module	Check that the oximetry module has been correctly applied	Visual	\	The doubled sided adhesives must be applied between the PCB and the greatest micro on the oximetry module

CHECKS ON MAIN CASING OF THE ASSEMBLED DEVICE

Table 2

Test	Procedure	Test method	Instrument	Expected results
Temperature	Check that the temperature corresponds to the BTPS*	Instrument	Thermometer	Temperature equal to thermometer reading +/- 1 °C
Date and time	Set time and date (see User Manual)	Visual/ Quantitative	\	The set parameters must remain as configured
Bluetooth	Carry out search for enabled devices	Visual	\	Device should be recognized by the PC used
Auto-off	switch on the device and leave it for 5 minutes	Visual	\	After 5 minutes the device switches off
Display	Switch on the device and check screen shots	Visual	\	All pixels must work correctly

* The BTPS appears on the main screen of display and on printout of a spirometry test

TESTS TO PERFORM AFTER POSITIVE RESULTS ARE OBTAINED FROM PREVIOUS TESTS

SPIROMETRY TEST

This test must be carried out as follows:

- a) Measure the ambient temperature using a digital thermometer and check that the BTPS value corresponds to the value in Table 3, the same temperature in the testing room.
- b) Fill in the FIVC nom (L) (min and max) fields of the SPIROMETRY TEST (Annex 1), min and max nominal values of current BTPS, from Table 3 below.
- c) Check that the stop of the 3 L calibration syringe is at “3.0”.
- d) Move the piston of the syringe so that the “0.0” of the calibrated shaft is positioned with the shaft exit.
- e) Connect the device with a mouthpiece to the calibration syringe.
- f) Make the FVC test.
- g) Push the piston at a constant rate until the “3.0” of the calibrated shaft is positioned with the shaft exit.
- h) Pull back the piston at the same rate as at letter (f) until the “0.0” of the calibrated shaft is positioned with the shaft exit.
- i) Push the piston until the “1.0” of the calibrated shaft is positioned with the shaft exit (0.5 L tolerance limit).
- j) Read the FVC, FIVC and 2575 measured values to enter the FVC, FIVC measured values in the proper field of the SPIROMETRY TEST (Annex 1 of this Manual).
- k) If the values given by the device are not within the set min and max volumes, analyze and resolve the problem, if there is no solution then the product must be identified as nonconforming.

At the end of the tests, the table contained in Annex 1 shall be completed.

The FVC (L) (min and max) nominal values contained in the SPIROMETRY TEST (Annex 1) are already inserted because the BTPS expiration factor is constant and equal to 1.026 (corresponding to 37°C, that is, the average body temperature).

At the end of the tests, where there are no negative results, the device is identified as conforming and can be returned to the user.

OXIMETRY TEST

This test must be performed using the following instruments:

- a) “Fluke Index 2XLFE”, SpO2 simulator used to simulate oxygen saturation
- b) The device to be tested
- c) The oximetry sensor cable

The testing procedure is as follows:

- a) Connect the sensor cable to the MIR device using the proper connector.
- b) Connect the sensor to the oximetry simulator ensuring the correct positioning as shown in the following image.
- c) Set the oximetry value on the simulator at 85% and BPM at 40.
- d) Launch the oximetry test on the MIR device (see User Manual).

TEMPERATURA AMBIENTE (C°)	BTPS	FIVC nominale	FIVC min	FIVC max
10	1,160	3,48	3,36	3,60
11	1,550	3,46	3,34	3,58
12	1,151	3,45	3,33	3,57
13	1,147	3,44	3,32	3,56
14	1,142	3,42	3,30	3,54
15	1,138	3,41	3,29	3,53
16	1,133	3,39	3,27	3,51
17	1,129	3,38	3,26	3,50
18	1,240	3,37	3,25	3,49
19	1,120	3,36	3,24	3,48
20	1,115	3,34	3,22	3,46
21	1,111	3,33	3,21	3,45
22	1,106	3,31	3,19	3,43
23	1,101	3,3	3,18	3,42
24	1,097	3,29	3,17	3,41
25	1,092	3,27	3,16	3,38
26	1,087	3,26	3,15	3,37
27	1,082	3,24	3,13	3,35
28	1,078	3,23	3,12	3,34
29	1,073	3,21	3,10	3,32
30	1,068	3,2	3,09	3,31
31	1,063	3,18	3,07	3,29
32	1,058	3,17	3,06	3,28
33	1,053	3,15	3,04	3,26
34	1,048	3,14	3,03	3,25
35	1,043	3,12	3,01	3,23
36	1,038	3,11	3,00	3,22
37	1,033	3,09	2,98	3,20
38	1,028	3,08	2,97	3,19
39	1,023	3,07	2,96	3,18
40	1,018	3,06	2,95	3,17

Table 3

FIVC min/max values, temperature or BTPS function

- e) Read the value given by the **Spirolab** (it must be between 83 and 87%).
- f) Read the heart beat rate on the MIR device (it must be between 38 and 42).

- g) Enter the given values in the proper spaces on Annex 1 to this Manual.
- h) Repeat the same procedure for the saturation level set on the simulator at 95% and PBM at 80.
- i) Read the value given by the **Spirolab** (it must be between 93 and 97%).
- j) Read the heart beat rate on the **Spirolab** (it must be between 78 e 82).
- k) Enter the given values in the proper spaces on Annex 1 to this Manual.

If the values of both tests are within the preset range, the sensor passes the checks and can be given to the user together with the device, otherwise it is nonconforming and should be subject to further tests.

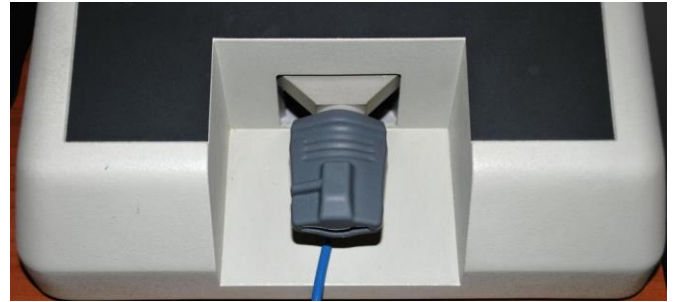

4.5.2. Testing procedures for devices without oximeter

The following checks must be carried out on each device:

Table 4

TESTS ON PCB MIR080 WITHOUT OXIMETER

Test	Procedure	Test method	Instrument	Expected result
Check battery pack application	there should be applied the double sided tape on the battery pack	Visual	\	The doubled sided adhesives must be applied between the PCB and the battery pack
Block of PCB on the lower case	There should be applied 11 screws and washers in the special holes	Visual	\	The screws should be all correctly screwed
Display application on the upper case	There should be applied 6 nuts and showers between display and case	Visual	\	The nuts should be all correctly screwed
White flat display application to the display	There should be applied and blocked with hot glue	Visual	\	Presence of hot glue on the connector
Brown flat display application	There should be applied a thick adhesive to the flat	Visual	\	Presence of a thick adhesive on the flat
Blocking of display flats	Application of thick adhesive on connectors J13 and CONN1	Visual	\	Presence of a thick adhesive on the two connectors

CHECKS ON MAIN CASING OF THE ASSEMBLED MACHINE

Repeat the same tests described in Table 2.

TESTS TO PERFORM AFTER POSITIVE RESULTS OBTAINED FROM PREVIOUS TESTS

SPIROMETRY TEST

Follow the instruction described in point “Spirometry test” some pages above. In this case to report the values obtained, use the form in annex 2.

At the end of the tests, where there are no negative results, the device is identified as conforming and can be returned to the user.

5. SPARE PARTS

This chapter deals with placing orders for spare parts (see appendix A) as well as the listing of actual spare parts (appendix A, spare parts list).

5.1. ORDERING

Spare parts can only be ordered if the following data is supplied:

- Part number
- Description
- Quantity
- Shipping details (Incoterms)

The required data is mentioned in Appendix A. For the current parts list please refer to the spare parts price list which is published every year.

MIR only supplies parts mentioned in Appendix A. Standard parts such as screws, nuts, cleaning agents and so on are not supplied by MIR, these parts must be purchased locally.

5.2. DELIVERY

5.2.1. Ordering PCB's

Printed circuit boards are only obtainable as spare part in their latest version. Consult the technical documentation for instructions of how to modify the latest version of the PCB for use in older versions of the equipment.

5.2.2. Warranty claims

Warranty claims must be provided with the MIR invoice number, the type of products and serial number of the equipment in question. The defective item must be returned back to MIR. The customer is responsible for the transportation and for all transport and customs charges for the delivery of the goods both to and from the service centre.

The customer must inform MIR about the substitution of a PCB. For the correct traceability the manufacturer must maintain the history of a single device during its life.

5.3. RETURN SHIPMENTS

Any instrument or accessory returned must be accompanied by a clear and detailed explanation of the defect or problem found.

If units are to be returned to MIR then a written or verbal permission (RAN - Return Authorization Number) must be received before any instrument is returned to MIR.

The unit must be returned in its original packaging.

MIR reserves the right to modify the instrument if required, and a description of any modification made will be sent along with the returned goods.

Note

Any instrument of accessory returned must be accompanied by a clear and detailed explanation of the defect or issue found.

6. TROUBLESHOOTING

Note

Where not indicated, voltages are measured versus the ground (i.e. the negative pole of the battery).
Where not indicated, voltages are measured while the unit is switched on.
Where not indicated, the values to be measured can vary by about 2%.



WARNING

Be careful not to short-circuit any contacts while measuring voltages.
Batteries may explode if defective or damaged or disposed of in fire.
Do not short-circuit the batteries!

6.1. The device does not switch on

Check the integrity of the internal battery .

If the device is connected to the battery charger and the battery is disconnected or compromised, the display shows the message:

Battery failure

If the battery charger is connected:

Check the battery charger:

- Make sure that the connector is fully inserted to the plug.
- Check the cable for visible damage.

Recharge battery

- Connect power cable to the device
- Check that the battery indicator on the display shows the correct charging phase
- When the charging is completed the battery indicator becomes green

6.2. The display remains black

Check that the flat connector of the display is not broken:

- Open the Spirolab (see Paragraph 4.2.1)
- Check that the connector is fully connected to the PCB
- Check that the flat is not excessively bent.

6.3. The battery is not working correctly

Check the battery charger

- Make sure that the main power supply's connector is correctly attached to the plug.
- Check the cable for visible damage.

Check the internal power supply

- Open the **Spirolab** (see Paragraph 4.2.1).
- Measure the voltage at the output of the battery . It must be approximately between 5,5 V and 7,2 V.

6.4. The device does not measure spirometry at all

- Check if any obstacle is blocking the free rotation of the turbine
- For information about maintenance cleaning please refer to paragraph 4.3.4.1 of this manual.
- The VC and MVV tests does not measure
 - Control if in service menu the standard is set up on NANHES III, in this case the VC and MVV tests does not work; thus set another author to make VC and MVV tests work

6.5. The device does not measure spirometry correctly

- Check if any obstacle is disturbing the free rotation of the turbine.
- For information about maintenance cleaning please refer to the paragraph 4.3.4.1 of this manual.
- Check the accuracy with the calibration syringe.
 - Make several tests FVC at different in/expiration speeds.
 - Check the measured volume. It may differ $\pm 3\%$ or 50 ml, depending on which value is bigger (i.e. using a 3000-ml-syringe, the measured valued must be between 2910 and 3090 ml, using a 1000-ml-syringe, between 950 and 1050 ml)

Check if a calibration has been made and if necessary recalibrate to original setting (see section Turbine Calibration in the User Manual).

6.6. The device does not measure oximetry at all

- Check if the devices is provided with the oximetry function or not
 - Switch on the device and access to the service menu as described in the user manual. Select the voice “info firmware” and check if there is shown the oximetry software version; if yes then the device has the oximetry function, otherwise no.

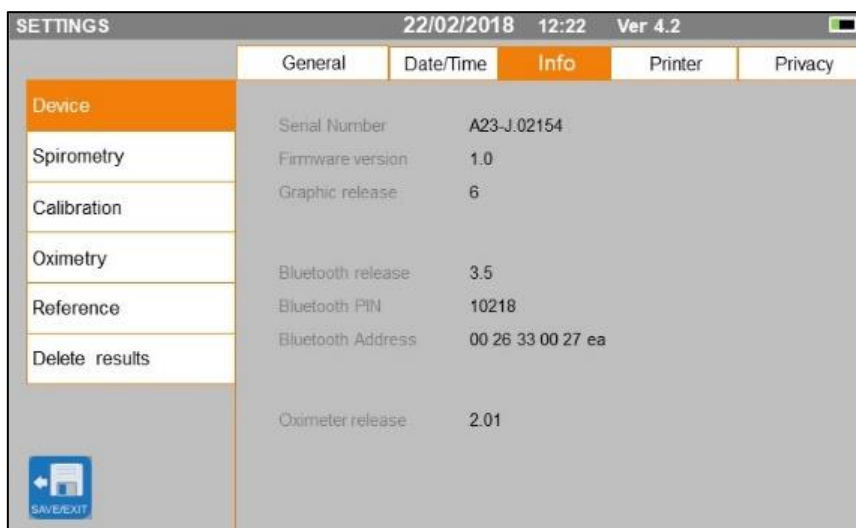

6.7. The device does not measure oximetry correctly

- Check the correct connection of the sensor
 - The connector must be fully inserted in the plug
 - Check if there is any damage on the cable connector
 - Check the correct position of the sensor on the patient, see section regarding the oximetry tests on the user manual

6.8. The data communication via USB does not function

- Check the cables, if there is any visible damage.

- Replace the cable
- If after changing the cable the problem persists, then send the device to the manufacturer
- ☑ Verify the correct installation of the winspiroPRO software
 - Check the winspiroPRO USB connection: from menu “Configuration”, “Options”, “Communication”
 - Check that the driver is installed in the following folder:

C:\MIR\winspiroPRO\Drivers\MIR USB drivers\

if the driver is not installed then it can be obtained from the manufacturer. Then copy it into the above-mentioned folder.

- If the problem persists contact the manufacturer.

6.9. Index of components

To simplify component identification they are marked in the attached drawing of the components layout of the Printed Circuit Board (PCB) MIR080.

See Appendix C for more information on the component name and description.

APPENDIX A: SPARE PARTS LIST

Battery Code: 972301

Rechargeable battery pack

Battery charger Code: 920660

Battery charger 220V/110V

Board Code: 891080

Mother board without oxymeter (oxy module)

Cable Code: 532362

Cable to connect miniflowmeter to Spirolab New

Cable Code: 532361

Micro USB cable for the PC connection

Carrying case Code: 672684

Carrying case (grey)

Case Code: 300599

Plastic case (ABS) orange/white, complete including screws

Case Code: 300600

Plastic door (ABS) white for printer compartment

Case Code: 300601

cutter (ABS) white for printer compartment

Case Code: 300604

Plastic cover (ABS) white for SIM compartment

Case Code: 300622

Plastic case (ABS) white, upper part

Case Code: 300623

Plastic case (ABS) white, lower part

Case Code: 300624

Plastic case (ABS) orange, central part

Case Code: 300607

on/off button

Case Code: 300629

Printer support

Case Code: 300898

Plastic case (ABS) white complete Miniflowmeter

Case Code: 300608

Rubber feet, set of 4

Display Code: 660584

Touch screen display 7"

Display Code: 512584

Flex strip to connect display touch to mother board

Flowmeter Code: 910595

Miniflowmeter with cable, without turbine flow meter

Printer Code: 660080

Thermal printer

Printer Code: 340834

Plastic support for thermal paper roll (diameter 10.5 mm)

APPENDIX B: SERVICE INFO'S (Product Change Notes)

General

The technical information in the service manuals of MIR S.p.A. is up to date at the date of issue.

Necessary additional information (of any kind) will be provided in the following way:

- as supplements to the manual, or
- as revised editions (chapters) of the manual, or
- as Service Info (product change notes).

When a supplement or a revision is made to the manual, a "document history file" is added to this chapter. This file will give information about the date of issue of supplements or revisions.

APPENDIX C

For oxy version: in addition to the components in the following table please consider the oxy module as follow:

Code	Description	PCB identification
001079	Oximetry module MIR046_B	\

List of Components

Code	Description	PCB identification
111588	Connettore plug alimentazione nero d = 2mm	J10
122005	Connettore maschio 2 pin 22035025 Molex	J1
123705_1	Connettore 40 pin OMRON XF2M-4015-1A passo 0.5mm	CONN1
123707	Connettore SMD Zif 10 pin pitch 1.0mm FCI SFW10R-1STAE1LF	J13
123714	Connettore SMD Zif 22-pin (lower contact type) pitch 1.0mm P/N.SFW22R-1STAE1 (FCI)	J3
123716	Connettore SMD Zif 4-pin (upper contact type) pitch 1.0mm P/N.SFW04R-2STAE1 (FCI)	J2, J4
124005	Connettore SMD 10PIN (Femmina) per ossimetro	CON2
124007	Connettore SMD 10PIN (Femmina) per turbina spirolab touch	CON1
125003	Connettore USB tipo A verticale PTH Molex 894858003	J6
125004	Connettore SMD USB series Micro-AB SD-47590-001 top mount (Molex)	J5
125500	Connettore RJ45 SMT low profile AMP 5406721_E	J8
130007_5PIN	Connector LOW PROFILE STRIP 2.54mm x 5 PIN FEMALE P/N PR105SB1	J15
130009	Connettore 6 pin dual row passo 2.0mm	J12
130011	Connettore 8 pin dual row passo 2.0mm	J12
130018	Connettore 2 pin strip maschio passo 2.54mm (cod. art. 650520)	JP1, JP2
130027	Connettore 8 pin pitch 1.27mm P/N.TMS-108-03-G-S-RA (Samtec)	J7
210858	Pulsante THT right angle FSM104 (Tyco) or equivalent P/N HSSA-21N-V	S1
272408	Fusibile LF154002-RA000 Portafusibile 2A LF	F1, F2
272412	Fusibile LF154004-RA000 Portafusibile 4A LF	F3, F4
330017	Induttanza SMD 3.3 uH 7A 6.5x7 SPM6530T-3R3 (TDK)	L1
330018	Induttanza SMD 4.7 UH 1.2A 4x4 VLS4012 (TDK)	L6
330029	Induttanza SMD 220ohm@100MHz 0805 2A 25% MURATA BLM21PG221SN1	L3, L4, L5
330100	Induttanza WE-PD2 100uH SIZE 1054 +/-10% IR=1.02A RDC=0.35 Ω	L2
361600	Integrato SMD USB Vbus supply TPS2051C_SOT23-5 (TI)	IC6
450150_07	PCB MIR 080 rev7 spirolab	MIR080_REV7
512489	Connettore backlight mating : SM02B-BHSS-1-TB	J11
560023	Buzzer SMD 5x5 3h mm SMT-G5030A Kepo o SFM-5540-03A	SP1
602622	Diodo MRA4003T3G on semiconductor	D2
602629	Diodo ESD protection bidirectional SMD 15V (SOD 323) Nexperia PESD15VL1BA	D3, D10
602632	Diodo SS34 Schottky 40V 3A	D4
602634	Diodo 1N4148W SMD package SOD 123	D5, D12
602637	Diodo ES3A-ES3B-ES3C-ES3D rectifier 3A SMC 50-200V	D1
602638	Diodo MBR0520LT1 diode Schottky SOD123	D6, D7, D8, D9, D11
610800	Transistor MMBF170LT1 MOSFET N SOT-23 Motorola	Q5

Code	Description	PCB identification
610900	Transistor XP132A1545SR MOSFET P SO-8 Torex	U6
610902	Transistor IRFU9024 MOSFET P DPACK IR	Q3
611930	Transistor MMBT3904LT1 NPN SOT-23 Rohm	TR1
612080	Transistor MMBT2222A SMD SOT 23 (SC59)	Q4, Q9
612081	Transistor SI1317DL-T1-GE3 Vishay CMOS SI1315DL-T1-GE3	Q7, Q11, Q20
612082	Transistor SI2302CDS-T1-GE3 Vishay MOSFET o AFN2302ASS23RG o AFN3414AS23RG	Q1, Q2, Q6, Q8, Q10, Q12, Q16, Q17, Q18, Q19
630255	Opto KPC357NT PC357N4J00F	IC3
640825	Integrato S812C25AMCCFT2 regolatore 2.5V Seiko	IC2
640827	Integrato SMD MIC33153YHJ Step-down indut. integrata 1.2A 14-MLF (Micrel)	U1
640828	Integrato SMD TPS54425 Regolatore switching 3V3 4A 14-HTSSOP (TEXAS)	U2
640850	Integrato Seiko S812C50AMCC3ET2G	U3, U4
641530	Sensore DS18B20U sensore di temperatura	IC7
642763	Integrato SMD MP6508GF TSSOP-16 stepper motor driver (MPS - MonolithicPowerSolution)	U10
644935	Integrato MAX 4715EXK-T/S	IC10
645424	Integrato MAX9119 SMD SC70 5 pin operazionale	IC8
645604	Integrato SMD 74LVC373APW - TSOP20	U9, U11
646458	Integrato SMD AS4C8M16SA-7TCN SDRAM 8Mx16 bit 54-TSOP_II	IC4
647222	Integrato MAX 8510 EXK33-T	IC11
647306	Integrato Voltage Regulator SMD TPS61166 Step-up x LED 9V9 400mA 10-QFN	U20
647308	Integrato SMD 2V5 200mA Low-Dropout Voltage Regulator SON-6 TLV70025 (TI)	IC1
647330	Integrato SMD TS3USB221RSE USB mux-switch 10-UQFN (Texas)	U17
647547	Integrato TEX BQ2004HSP battery charger SMD	U5
648030	Integrato 74HC74PW SMD D flip flop TSSOP	IC9
648174	Integrato SMD Microcontrollore PIC32MX695F512L 32-Bit con ETH, USB, 512KB Flash , 128KB RAM, 100-pin	U18
648192	Integrato SMD Controllore grafico S1D13517 QFP15 128 pin	U19
648395	Integrato memoria FM33256 SO14 3V Memory	IC5
648397	Integrato SMD 64Mbit Serial FLASH SST26VF064B(T)-104I/SM	U15
680400	Quarzo SMD 32,768KHz Q13FC1353276800 Epson o CM315D32768DZFT CITIZEN	X1
680511	Quarzo SMD 8MHz crystal 14pF +-30ppm	Y1
680522	Oscillatore SMD3.2x2.5x1 mm Voltage controlled Temp. compensated 24MHz SG-210 24,000000M OSC STF L	X2
710506	Resistenza C/F resistor 1W 0,22 OHM 5%	R27
712600_1_0603	Resistenza SMD 0603 0,1W 1% 0	R90, R91
712642_1_0603	Resistenza SMD 00603 0,1W 1% 220	R24, R30, R30_1
712648_0603	Resistenza SMD 0603 0,1W 5% 330	R25
712655_1_0603	Resistenza SMD 0603 0,1W 1% 442K	R4, R55
712660_0603	Resistenza SMD 0603 0,1W 5% 1K	R26, R32, R51
712668_0603	Resistenza SMD 0603 0,1W 5% 2K2	R11, R93
712670_1_0603	Resistenza SMD 0603 0,1W 1% 3K	R81
712673_1_0603	Resistenza SMD 0603 0,1W 1% 3.57K	R22
712675_1_0603	Resistenza SMD 0603 0,1W 1% 4K53	R18

Code	Description	PCB identification
712676_0603	Resistenza SMD 0603 0,1W 5% 4K7	R17, R45, R50, R53, R54, R75, R77
712680_0603	Resistenza SMD 0603 0,1W 5% 6K8	R13
712684_0603	Resistenza SMD 0603 0,1W 5% 10K	R1, R2, R33, R40, R44, R48, R49, R58, R60, R68, R86, R87, R88, R89, R98
712692_1_0603	Resistenza SMD 0603 0,1W 1% 22K	R6
712694_1_0603	Resistenza SMD 0603 0,1W 1% 27K4	R23
712696_1_0603	Resistenza SMD 0603 0,1W 1% 30K	R16, R29, R31, R35
712702_1_0603	Resistenza SMD 0603 0,1W 1% 73K2	R19, R99
712708_0603	Resistenza SMD 0603 0,1W 5% 100K	R10, R15, R20, R34, R43, R52, R61, R62, R63, R66, R69, R70, R71, R73, R74, R84, R92
712708_1_0603	Resistenza SMD 0603 0,1W 1% 100K	R5, R7, R12, R12_b, R14
712710_1_0603	Resistenza SMD 0603 0,1W 1% 120K	R3, R80
712717_1_0603	Resistenza SMD 0603 0,1W 1% 249K	R8, R9, R36, R41, R42, R47, R56, R57, R59, R65, R72, R76, R78, R85
712725_0603	Resistenza SMD 0603 0,1W 5% 510K	R21, R28, R46, R83, R94
712780_0603	Resistenza SMD 0603 0,1W 5% 1M	R67
712781_0603	Resistenza SMD 0603 0,1W 5% 2M2	R64
712906_1_1206	Resistenza SMD 1206 0,25W 1% 0R5	R37, R38, R39, R82, R82_b, R95, R96, R97
801798	Capacitor elettrolitica 1000uF 16V radiale	C20, C33, C35
802240	Capacitor ELE SMD 16V 20% 100u	C24
810030	Capacitor CER SMD 1206 10V X7R 22uF	C5, C58
810038	Capacitor TANT SMD B 6,3V 20% 100u LOW ERS	C22
810039	Capacitor TANT SMD C 10V 20% 100uF LOW ESR	C61
810068_0603_10	Capacitor TANT SMD P 10V 20% 1uF Nichicon	C55, C76, C79, C80
810095	Capacitor TANT SMD E 10V 470uF	C102
810096	Capacitor TANT SMD Y 6V3 470uF	C56
831708_0603	Capacitor CER SMD 0603 16V X7R 22p	C9, C73, C74
831731_0603	Capacitor CER SMD 0603 25V 10% X7R 3300pF	C10
831732_0603	Capacitor CER SMD 0603 50V X7R 1nF	C25, C26, C32, C95, C105, C113, C114, C12, C12_b
831739_0603	Capacitor CER SMD 0603 16V X7R 10nF	C34, C39, C45, C57, C98, C103, C106, C107, C108, C109, C110, C111, C112
831746_0603	Capacitor CER SMD 0603 25V X7R 0,1u	C2, C6, C13, C14, C17, C18, C21, C23, C23_1, C28, C29, C31, C36, C37, C40, C42, C43, C46, C47, C48, C49, C50, C51, C52, C53, C54, C59, C60, C62, C64, C66, C67, C68, C69, C70, C71, C72, C75, C77, C78, C81, C82, C83, C84, C85, C86, C87, C88, C89, C90, C91, C92, C93, C94, C96, C97, C101, C104
832146	Capacitor CER SMD 0805 16V 4u7 X5R	C4, C15, C16, C99, C100
832150_0603	Capacitor CER SMD 0603 16V/25V X7R/X5R 1u	C11, C19, C30, C38, C41, C41_b, C63
832150_1210	Capacitor CER SMD 1210 16V 10u X7R PAN ECJ4YB1E106M	C1, C3, C65
832160_1206	Capacitor CER SMD 1206 10V X5R 47uF	C7, C8

ANNEX

- 1 Test report form after device repair with oximetry module
- 2 Test report form after device repair without oximetry module