



SEL-451 Protection, Automation, and Bay Control System

Protection, Automation, and Bay Control System



Key Features and Benefits

The SEL-451 Protection, Automation, and Bay Control System integrates bay control for breakers and disconnect switches with full automation and protection in one device. This data sheet applies to the SEL-451-5 and -A relays. Table 6 details which features, functions, and applications are supported by each of the SEL-451 models.

- **High-Impedance Fault (HIF) Detection.** The optional HIF detection element operates for small current ground faults typically caused by downed conductors on surfaces such as earth, concrete or other poorly conductive materials. HIF event data are made available in standard COMTRADE format.
- **Synchronism Check.** Synchronism check can prevent circuit breakers from closing if the corresponding phases across the open circuit breaker are excessively out of phase, magnitude, or frequency. The synchronism-check function has a user-selectable synchronizing voltage source and incorporates slip frequency, two levels of maximum angle difference, and breaker close time into the closing decision.
- **Reclosing.** You can incorporate programmable reclosing of one or two breakers into an integrated substation control system. Synchronism and voltage checks from multiple sources provide complete bay control.
- **Fault Locator.** Utilities can efficiently dispatch line crews to quickly isolate line problems and restore service faster.
- **Dual CT Input.** You can combine currents within the relay from two sets of CTs for protection functions, but keep them separately available for monitoring and station integration applications.
- **Primary Potential Redundancy.** Multiple voltage inputs to the relay provide primary voltage input redundancy. Upon loss-of-potential (LOP) detection, the relay can use inputs from an electrically equivalent source connected to the relay.
- **Low-Energy Analog (LEA) Inputs.** As many as six IEEE C37.92-compliant LEA voltage inputs can reduce costs and save space.
- **Comprehensive Metering.** The built-in, high-accuracy metering functions can improve feeder loading. Watt and VAR measurements optimize feeder operation. Minimize equipment needs with full metering capabilities including rms, maximum/minimum, demand/peak, energy, and instantaneous values.
- **Auxiliary Trip/Close Pushbuttons.** These optional pushbuttons are electrically isolated from the rest of the relay. They function independently from the relay and do not need relay power.

- ▶ **Bay Control.** The relay provides bay control functionality with status indication and control for disconnect switches. The relay features control for as many as two breakers and status indication of as many as three breakers. Numerous predefined user-selectable mimic displays are available; the selected mimic appears on the front-panel screen in one-line diagram format. The one-line diagram includes user-configurable labels for disconnect switches, breakers, bay name, and display for as many as six analog quantities. The relay features SELOGIC programmable local control supervision of breaker and disconnect switch operations.
- ▶ **Breaker Failure.** High-speed (less than one cycle) open-pole detection logic reduces coordination times for critical breaker failure applications. Apply the relay to supply breaker failure protection for all supported breakers. Logic for breaker failure retrip and initiation of transfer tripping is included.
- ▶ **IEC 60255-149 Compliant Thermal Model.** The relay can provide a configurable thermal model for the protection of a wide variety of devices. This function can activate a control action or issue an alarm or trip when equipment overheats as a result of adverse operation conditions. A separate resistance temperature detector (RTD) module is required for this application.
- ▶ **Ethernet Access.** The optional Ethernet card grants access to all relay functions. Use IEC 61850 Manufacturing Message Specification (MMS) or DNP3 protocol directly to interconnect with automation systems. You can also connect to DNP3 networks through a communications processor. Use File Transfer Protocol (FTP) for high-speed data collection. Connect to substation or corporate LANs to transmit synchrophasors by using TCP or UDP internet protocols.
- ▶ **Serial Data Communication.** The relay can communicate serial data through SEL ASCII, SEL Fast Message, SEL Fast Operate, MIRRORED BITS[®], and DNP3 protocols. Synchrophasor data are provided in either SEL Fast Message or IEEE C37.118 format.
- ▶ **Automation.** The enhanced automation features include programmable elements for local control, remote control, protection latching, and automation latching. Local metering on the large front-panel LCD eliminates the need for separate panel meters. Serial and Ethernet links efficiently transmit key information, including metering data, protection element and control I/O status, synchrophasor data, IEC 61850 Edition 2 GOOSE messages, Sequential Events Recorder (SER) reports, breaker monitoring, relay summary event reports, and time synchronization. Apply expanded SELOGIC[®] control equations with math and comparison functions in control applications. Incorporate as many as 1000 lines of automation logic to accelerate and improve control actions.
- ▶ **Synchrophasors.** You can make informed load dispatch decisions based on actual real-time phasor measurements from relays across your power system. Record streaming synchrophasor data from the relay for system-wide disturbance recording. Control the power system by using local and remote synchrophasor data.
- ▶ **Breaker and Battery Monitoring.** You can schedule breaker maintenance when accumulated breaker duty (independently monitored for each pole) indicates possible excess contact wear. The relay records electrical and mechanical operating times for both the last operation and the average of operations since function reset. Alarm contacts provide notification of substation battery voltage problems (as many as two independent battery monitors in some SEL-400 series relays) even if voltage is low only during trip or close operations.
- ▶ **Six Independent Settings Groups.** The relay includes group logic to adjust settings for different operating conditions, such as station maintenance, seasonal operations, emergency contingencies, loading, source changes, and adjacent relay settings changes. Select the active group settings by control input, command, or other programmable conditions.
- ▶ **Software-Invertible Polarities.** Inverting individual or grouped CT and PT polarities allows you to account for field wiring or zones of protection changes. CEV files and all metering and protection logic use the inverted polarities, whereas COMTRADE event reports do not use inverted polarities but rather record signals as applied to the relay.
- ▶ **Parallel Redundancy Protocol (PRP).** PRP provides seamless recovery from any single Ethernet network failure. The Ethernet network and all traffic are fully duplicated with both copies operating in parallel.
- ▶ **IEC 61850 Operating Modes.** The relay supports IEC 61850 standard operating modes such as Test, Blocked, On, and Off.
- ▶ **IEEE 1588, Precision Time Protocol (PTP).** PTP provides high-accuracy timing over an Ethernet network.
- ▶ **Digital Relay-to-Relay Communications.** Mirrored Bits communications can monitor internal element conditions between bays within a station, or between stations, using SEL fiber-optic transceivers. Send digital, analog, and virtual terminal data over the same Mirrored Bits channel.
- ▶ **Sequential Events Recorder (SER).** The SER records the last 1000 events, including setting changes, startups, and selectable logic elements.

- **Oscillography and Event Reporting.** The relay records voltages, currents, and internal logic points at a sampling rate as fast as 8 kHz. Offline phasor and harmonic-analysis features allow investigation of bay and system performance. Time-tag binary COMTRADE event reports with high-accuracy time stamping for accuracy better than 10 ms.
- **Digitally Signed Upgrades.** The relay supports upgrading the relay firmware with a digitally signed upgrade file. The digitally signed portion of the upgrade file helps ensure firmware and device authenticity after it is sent over a serial or Ethernet connection.
- **Increased Security.** The relay divides control and settings into seven relay access levels; the relay has separate breaker, protection, automation, and output access levels, among others. Set unique passwords for each access level.
- **Rules-Based Settings Editor.** You can communicate with and set the relay by using an ASCII terminal or use QuickSet to configure the relay and analyze fault records with relay element response. Use as many as 200 aliases to rename any digital or analog quantity in the relay.

Functional Overview

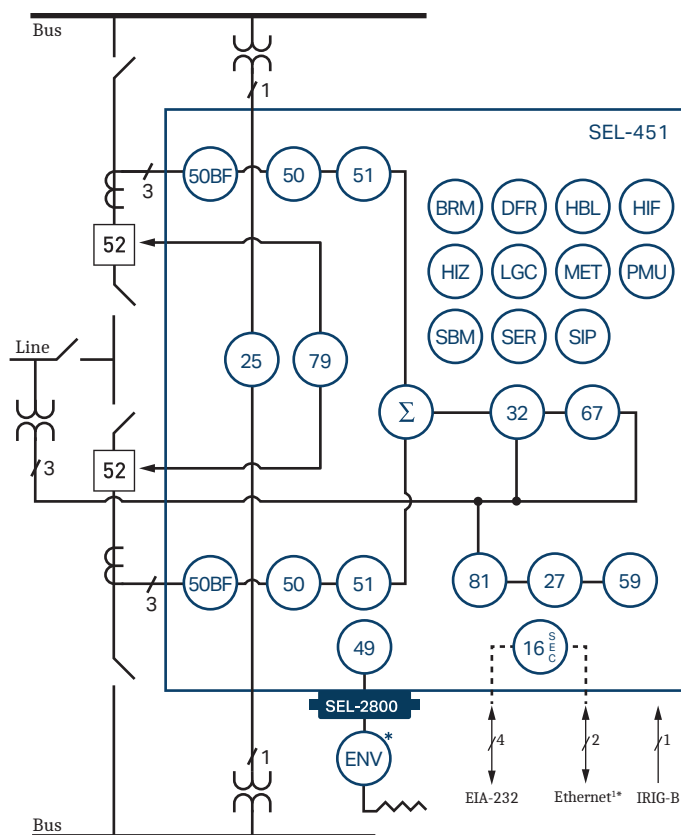

ANSI NUMBERS/ACRONYMS AND FUNCTIONS

25	Synchronism Check
27	Undervoltage
32	Over- and Underpower
50	Overcurrent
50BF	Dual Breaker Failure Overcurrent
51	Time-Overcurrent
52PB	Trip/Close Pushbuttons*
59	Overvoltage
67	Directional Overcurrent
79	Autoreclosing
81	Over- and Underfrequency

ADDITIONAL FUNCTIONS

16 SEC	Access Security (Serial, Ethernet)
85 RIO	SEL MIRRORING BITS Communications
BRM	Breaker Wear Monitor
DFR	Event Reports
ENV	SEL-2600 RTD Module*
HBL	Harmonic Blocking
HIF	High-Impedance Fault Detection Arc Sense Technology (AST)*
HIZ	Ground Overcurrent HIF Detection
LGC	SEL _{LOGIC} Control Equations
LOC	Fault Locator
MET	High-Accuracy Metering
PMU	Synchrophasors
RTU	Remote Terminal Unit*
SBM	Station Battery Monitor
SER	Sequential Events Recorder
SIP	Software-Invertible Polarities

¹ Copper or Fiber Optic

* Optional Feature

Figure 1 Functional Overview

Protection Features

Overcurrent Elements

The SEL-451 includes four phase, four negative-sequence, and four ground instantaneous overcurrent elements. The SEL-451 also includes six selectable operating quantity inverse-time overcurrent elements. You can

select the operating quantities from the following:

IA, IB, IC, MAX(IA, IB, IC), I1, 3I2, IG

where IA, IB, IC can be fundamental or rms quantities from either circuit breaker or combined currents.

The time-overcurrent curves (listed in *Table 1*) have two reset characteristic choices for each time-overcurrent element. One choice resets the elements if current drops below pickup for one cycle. The other choice emulates the reset characteristic of an electromechanical induction disc relay.

Table 1 Time-Overcurrent Curves

U.S.	IEC
Moderately Inverse	Standard Inverse
Inverse	Very Inverse
Very Inverse	Extremely Inverse
Extremely Inverse	Long-Time Inverse
Short-Time Inverse	Short-Time Inverse

Directional Elements

The SEL-451 includes a number of directional elements for supervision of overcurrent elements. The negative-sequence directional element uses the same patented principle proven in the SEL-351. This directional element can be applied in virtually any application, regardless of the amount of negative-sequence voltage available at the relay location.

The following three directional elements working together provide directional control for the ground overcurrent elements:

- ▶ Negative-sequence voltage-polarized directional element
- ▶ Zero-sequence voltage-polarized directional element
- ▶ Zero-sequence current-polarized directional element

Our patented Best Choice Ground Directional Element selects the best ground directional element for the system conditions and simplifies directional element settings. (You can override this automatic setting feature for special applications.)

Communications-Assisted Tripping Schemes

Use communications to improve tripping time for better customer service. The SEL-451 is the ideal relay for use in pilot-based tripping schemes. Enhanced MIRRORING BITS communications with SEL fiber-optic transceivers provide 3–6 ms relay-to-relay transmission time. Among the schemes supported are the following:

- ▶ Permissive overreaching transfer tripping (POTT)
- ▶ Directional comparison unblocking (DCUB)
- ▶ Directional comparison blocking (DCB)

Use the SELOGIC control equation TRCOMM to program specific elements, combinations of elements, inputs, etc., to perform communications scheme tripping and other scheme functions. The logic readily accommodates the following conditions:

- ▶ Current reversals
- ▶ Breaker open at one terminal
- ▶ Weak-infeed conditions at one terminal
- ▶ Switch-onto-fault conditions

LOP Logic Supervises Directional Elements

The SEL-451 includes logic to detect an LOP caused by failures such as blown fuses, which can cause an incorrect operation in directional elements. Simple settings configure the LOP logic to either block or force forward ground and phase directional elements under these conditions. The logic checks for a sudden change in positive-sequence voltage without a corresponding change in positive- or zero-sequence current. Tests and field experience show that this principle is very secure and is faster than the tripping elements.

HIF Detection

HIFs are short-circuit faults with fault currents smaller than what a traditional overcurrent protective relay can detect. The SEL-451 includes logic used to detect HIF signatures without being affected by loads and other system operation conditions. A running average provides a stable pre-fault reference and adaptive tuning learns and tunes out feeder ambient noise conditions. Decision logic differentiates an HIF condition from other system conditions such as switching operations and noisy loads. As much as 40 minutes of HIF activity is stored in high-resolution COMTRADE format and a summary of HIF activity is available using ASCII commands. View important HIF data from available metering commands.

Combined Current for Protection Flexibility

In traditional relays, when protecting a line fed from two breakers, such as a breaker-and-a-half system or double-breaker system, you needed to combine the CT inputs before connecting these inputs to the relay. The SEL-451 can accept separate inputs from two separate CTs and mathematically combine the currents. This allows collecting separate current metering and breaker monitor information for each breaker. Breaker monitoring functions for two breakers are done within one relay. Individual breaker currents allow for breaker failure functions on a per-breaker basis within the SEL-451. Breaker diag-

nostic reports from the SEL-451 provide you comparative breaker information that you can use for advanced, proactive troubleshooting.

Custom Control Capabilities

Customize control capabilities, adding stability and security to your system.

- ▶ Use expanded SELOGIC control equations to create advanced stability enhancements such as VAR-flow controlled time undervoltage load shedding.
- ▶ Combine frequency elements with voltage supervision for added security with underfrequency load-shedding systems.

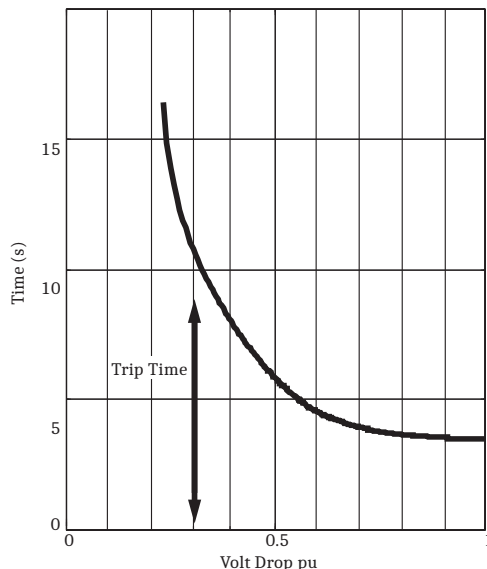

Figure 2 VAR-Flow Controlled Time Undervoltage Load Shedding

Multifunction Reclosing With Flexible Applications

The SEL-451 includes three-pole trip and reclose functions for either one or two breakers (*Figure 3*). Synchronism check is included for breaker control. Synchronizing and polarizing voltage inputs are fully programmable with dead line/dead bus closing logic, as well as zero-closing-angle logic to minimize system stress upon reclosing. Program as many as four reclose attempts. Select leader and follower breakers directly, or use a SELOGIC control equation to determine reclosing order based on system conditions.

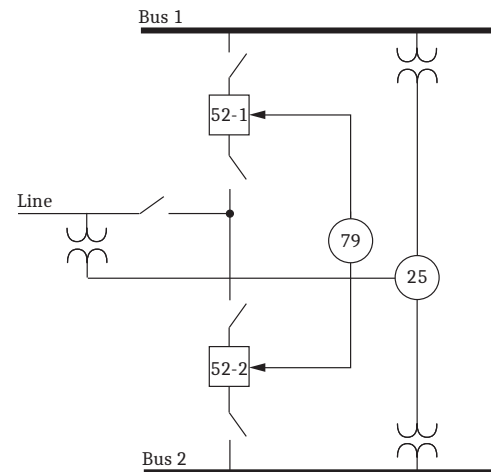

Figure 3 Two-Breaker Reclosing With Synchronism Check

Neutral Overcurrent Protection

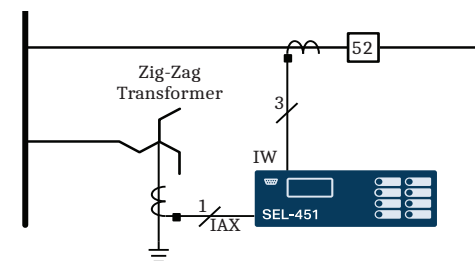

Figure 4 Single-Breaker Application With Overcurrent Protection

The SEL-451 measures the feeder currents as well as the current from a neutral source. *Figure 4* shows the three-phase feeder currents wired to Terminal IW, and the neutral current is wired to Terminal IAX. Use SELOGIC control equations to implement the definite-time overcurrent (50N) element for the neutral current source. Configure the selectable inverse-time overcurrent element to use Terminal IAX current as the operating quantity for implementing the 51N element.

Backup Protection

Add reliability and dependability by providing independent backup protection without increasing relay count. Use each SEL-451 to provide primary directional overcurrent protection with backup nondirectional overcurrent protection on the adjacent feeder. For additional flexibility, use the available I/O or MIRRORED BITS communications to switch protection upon loss of one relay.

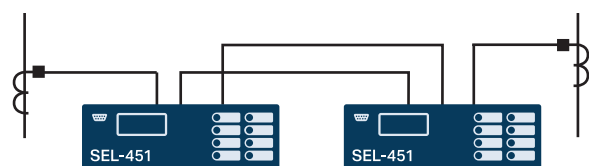

Figure 5 Using Two Cross-Connected SEL-451 Relays to Provide Primary and Backup Protection for Two Feeders

Additional Features

Front-Panel Display

The LCD shows event, metering, settings, and relay self-test status information. The target LEDs display relay target information as shown in *Figure 6*.

Figure 6–Figure 8 show close-up views of the front panel of the SEL-451. The front panel includes a 128 x 128 pixel, 3" x 3" LCD screen; LED target indicators; and pushbuttons with indicating LEDs for local control functions. The asserted and deasserted colors for the LEDs are programmable. Configure any of the direct-acting pushbuttons to navigate directly to an HMI menu item, such as events, bay display, alarm points, display points, or the SER.

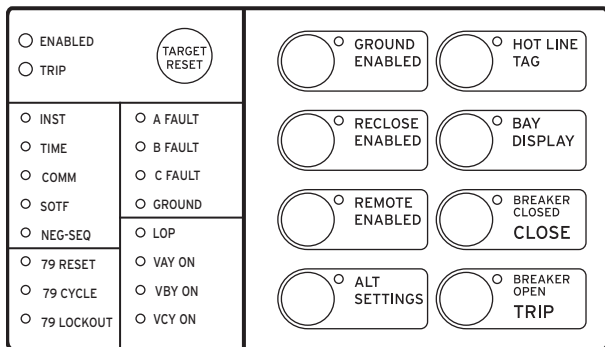

Figure 6 Factory-Default Status and Trip Target LEDs (8 Pushbutton, 16 Target Option)

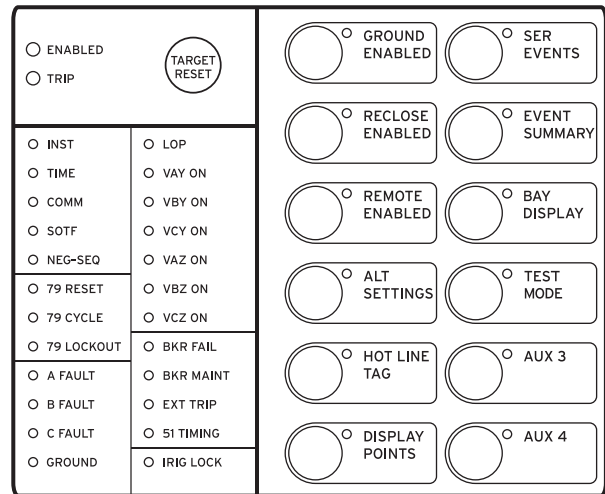

Figure 7 Factory-Default Status and Trip Target LEDs (12 Pushbutton, 24 Target Option)

The LCD is controlled by the navigation pushbuttons (*Figure 8*), automatic messages the relay generates, and programmable analog and digital display points. The rotating display scrolls through the bay screen, alarm points, display points, and metering screens. Each dis-

play remains for an adjustable time (1–15 s) before the display continues scrolling. Any message generated by the relay because of an alarm condition takes precedence over the rotating display.

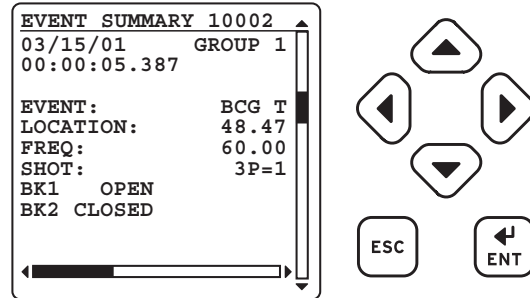

Figure 8 Front-Panel Display and Pushbuttons

Bay Control

The SEL-451 provides dynamic bay one-line diagrams on the front-panel screen with disconnect and breaker control capabilities for numerous predefined user-selectable bay types. You can download the QuickSet interface from selinc.com to obtain additional user-selectable bay types. The bay control can control as many as ten disconnects and two breakers, depending on the one-line diagram selected. Certain one-line diagrams provide status for as many as three breakers and ten disconnect switches. Operate disconnects and breakers with ASCII commands, SELOGIC control equations, Fast Operate Messages, and from the one-line diagram. The one-line diagram includes user-configurable apparatus labels and as many as 24 user-definable analog quantities.

One-Line Bay Diagrams

The SEL-451 offers a variety of preconfigured one-line diagrams for common bus configurations. Once you select a one-line diagram, you can customize the names for all of the breakers, disconnect switches, and buses. Most one-line diagrams contain analog display points. You can set these display points to any of the available analog quantities with labels, units, and scaling. The SEL-451 updates these values along with the breakers and switch position in real time to give instant status and complete control of a bay. The following diagrams demonstrate some of the preconfigured bay arrangements available in the SEL-451.

Programmable interlocks help prevent operators from incorrectly opening or closing switches or breakers. The SEL-451 not only prevents the operator from making an incorrect control decision, but can notify and/or alarm when an incorrect operation is initiated.

Circuit Breaker Operations From the Front Panel

Figure 9–Figure 12 are examples of some of the many selectable one-line diagrams in the SEL-451. Select the one-line diagram from the Bay settings. Additional settings for defining labels and analog quantities are also found in the Bay settings. One-line diagrams are composed of the following:

- ▶ Bay names and bay labels (bay labels available in one-line diagrams 14, 17, 18, and 23. All other one-line diagrams use the bay name.)
- ▶ Busbar and busbar labels
- ▶ Breaker and breaker labels
- ▶ Disconnect switches and disconnect switch labels
- ▶ Analog display points

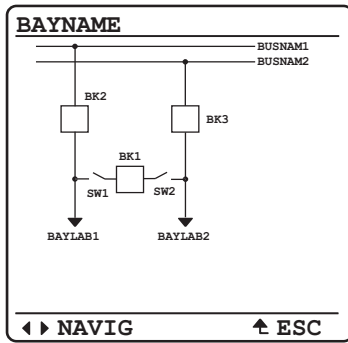

Figure 9 Breaker-and-a-Half

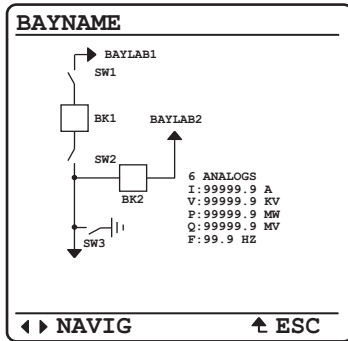

Figure 10 Ring Bus With Ground Switch

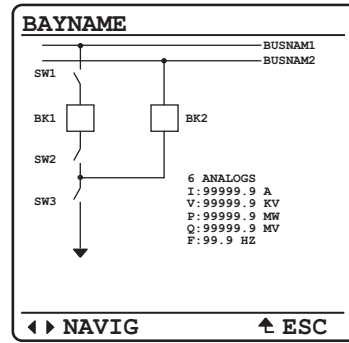

Figure 11 Double Bus/Double Breaker

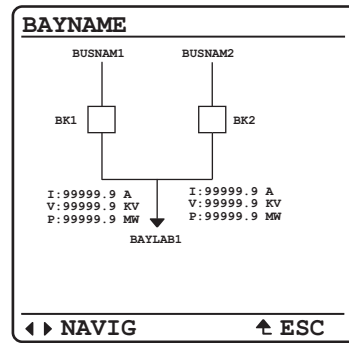

Figure 12 Source Transfer Bus

Figure 13 shows the breaker control screens available when the ENT pushbutton is pressed with the circuit breaker highlighted as shown in Figure 13(a).

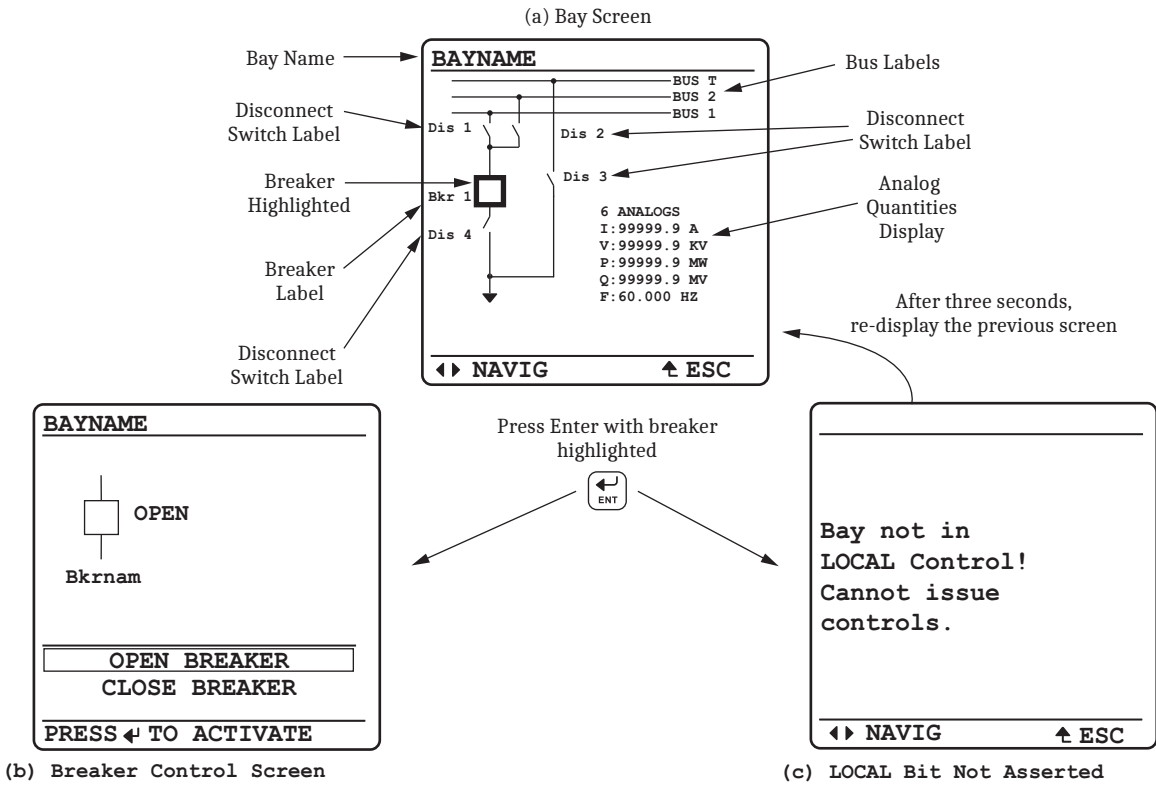

Figure 13 Screens for Circuit Breaker Selection

Rack-Type Breakers Mosaics

The SEL-451 supports the display of rack-type (also referred to as truck-type) circuit breakers. The rack-type breakers have three positions: racked out, test, and racked in. When in the test or racked-in positions, the breaker can be displayed as open or closed. When racked out, there is no breaker open/close display. The rack-type breakers are a display-only functionality and do not impact any circuit breaker control capabilities.

Status and Trip Target LEDs

The SEL-451 includes programmable target LEDs, as well as programmable direct-action control pushbuttons/LEDs on the front panel. *Figure 6* and *Figure 7* show these targets.

The SEL-451 features a versatile front panel that you can customize to fit your needs. Use SELOGIC control equations and slide-in configurable front-panel labels to change the function and identification of target LEDs and operator control pushbuttons and LEDs. The blank slide-in label set is included with the SEL-451. You can use templates supplied with the relay or hand label supplied blank labels and print label sets from a printer.

Alarm Points

You can display messages on the SEL-451 front-panel LCD that indicate alarm conditions in the power system. The relay uses alarm points to place these messages on the LCD.

Figure 14 shows a sample alarm points screen. The relay can display as many as 66 alarm points. The relay automatically displays new alarm points while in manual-scrolling mode and in autoscrolling mode. Assign the alarm point messages by using SER Points settings. The asterisk next to the alarm point indicates an active alarm. Use the front-panel navigation pushbuttons to clear inactive alarms.

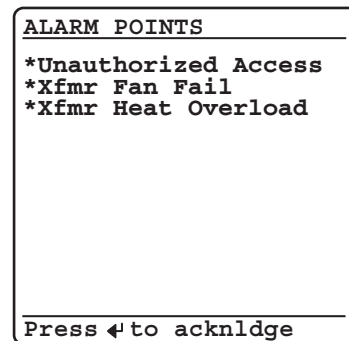

Figure 14 Sample Alarm Points Screen

Advanced Display Points

Create custom screens showing metering values, special text messages, or a mix of analog and status information with programmable display points. *Figure 15* shows an example of how you can use display points to show circuit breaker information and current metering. You can create as many as 96 display points. All display points occupy only one line on the display at all times. The height of the line is programmable as either single or double, as shown in *Figure 15*. These screens become part of the autoscrolling display when the front panel times out.

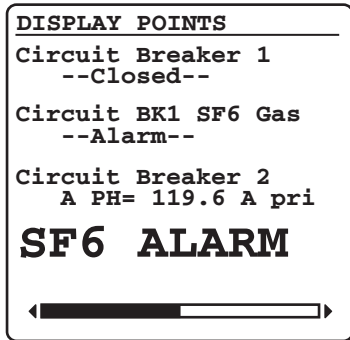

Figure 15 Sample Display Points Screen

Auxiliary Trip/Close Pushbuttons and Indicating LEDs

Optional auxiliary trip and close pushbuttons (see *Figure 16*) and indicating LEDs allow breaker control independent of the relay. The auxiliary trip/close pushbuttons are electrically separate from the relay, operating even if the relay is turned off.

The auxiliary trip/close pushbuttons incorporate an arc suppression circuit for interrupting dc trip or close current. To use these pushbuttons with ac trip or close circuits, disable the arc suppression for either pushbutton by changing jumpers inside the SEL-451. The operating voltage ranges of the breaker CLOSED and breaker OPEN indicating LEDs are also jumper-selectable.



Figure 16 Operator Controls (Auxiliary Trip/Close Model)

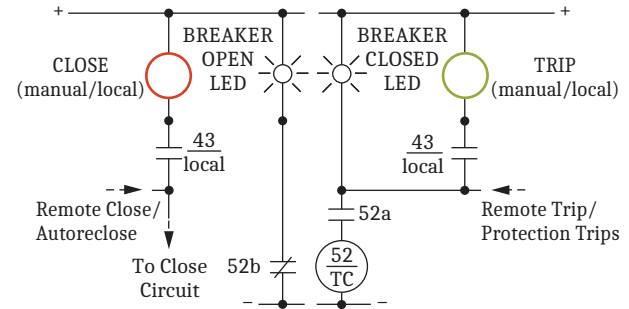

Figure 17 Optional Breaker Trip/Close Control Switches and Indicating Lamps

Control Inputs and Outputs

The basic SEL-451 includes five independent and two common inputs, two Form A and three Form C standard interrupting outputs, and three Form A high-current interrupting outputs. Refer to *Models and Options on page 20* for the available I/O boards.

Assign the control inputs for protection and control functions, monitoring logic, and general indication. You can use SELLOGIC control equations to program each control output. No additional I/O boards can be added to the 3U chassis; however, you can add one board to the 4U chassis, two I/O boards to the 5U chassis, and four I/O boards to the 8U chassis.

Communications Features

See *Specifications on page 23* for specific supported protocols.

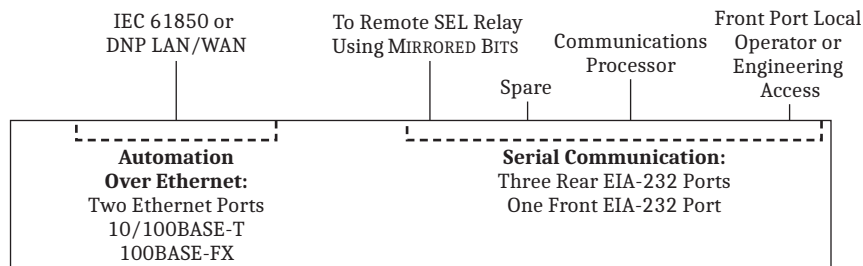

Figure 18 System Functional Overview

The relay offers the following communications features:

- ▶ Four independent EIA-232 serial ports.
- ▶ Access to event history, relay status, and meter information from the communications ports.
- ▶ Password-controlled settings management and automation features.
- ▶ SCADA interface capability, including FTP, IEC 61850, DNP3 LAN/WAN (via Ethernet), and DNP3 (via serial port). The relay does not require special communications software. You only need ASCII terminals, printing terminals, or a computer supplied with terminal emulation and a serial communications port.
- ▶ Synchrophasor data at 60 message-per-second data format.

Ethernet Card

Use popular Telnet applications for easy terminal communications with SEL relays and other devices. Transfer data at high speeds for fast file uploads. The Ethernet card communicates using FTP applications for easy and fast file transfers.

Communicate with SCADA by DNP3 and other substation IEDs by using IEC 61850 Manufacturing Message Specification (MMS) and GOOSE messaging.

Choose Ethernet connection media options for primary and standby connections:

- ▶ 10/100BASE-T twisted pair network
- ▶ 100BASE FX fiber-optic network

Telnet and FTP

Use Telnet to access relay settings, metering, and event reports remotely by using the ASCII interface. Use FTP to transfer settings files to and from the relay via the high-speed Ethernet port.

DNP3 LAN/WAN

DNP3 LAN/WAN provides the relay with DNP3 Level 2 Outstation functionality over Ethernet. Configure DNP3 data maps for use with specific DNP3 masters.

PTP

The Ethernet card provides the ability for the relay to accept IEEE 1588 PTPv2 for data time synchronization. PTP support includes the Default, Power System, and Power Utility Automation Profiles. When connected directly to

a grandmaster clock providing PTP at 1-second synchronization intervals, the relay can be synchronized to an accuracy of ± 100 ns in the PTP time scale.

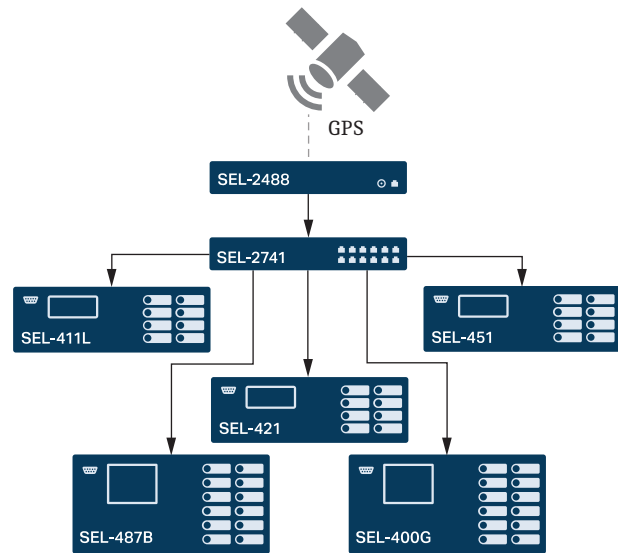

Figure 19 Example PTP Network

SNTP Time Synchronization

Use SNTP to synchronize relays to as little as ± 1 ms with no time source delay. Use SNTP as a primary time source, or as a backup to a higher accuracy time input to the relay.

PRP

Use PRP to provide seamless recovery from any single Ethernet network failure, in accordance with IEC 62439-3. The Ethernet network and all traffic are fully duplicated with both copies operating in parallel.

HTTP Web Server

The relay can serve read-only webpages displaying certain settings, metering, and status reports. The web server also allows quick and secure firmware upgrades over Ethernet. As many as four users can access the embedded HTTP server simultaneously.

IEC 61850 Ethernet Communications

IEC 61850 Ethernet-based communication protocols provide interoperability between intelligent devices within the substation. Standardized logical nodes allow interconnection of intelligent devices from different manufacturers for monitoring and control of the substation.

Eliminate system RTUs by streaming monitor and control information from the intelligent devices directly to remote SCADA client devices.

You can order the relay with IEC 61850 protocol for relay monitor and control functions, including:

- ▶ As many as 128 incoming GOOSE messages. You can use the incoming GOOSE messages to control as many as 256 control bits in the relay with <3 ms latency from device to device depending on network design. These messages provide binary control inputs to the relay for high-speed control functions and monitoring.
- ▶ As many as eight outgoing GOOSE messages. Configure outgoing GOOSE messages for Boolean or analog data such as high-speed control and monitoring of external breakers, switches, and other devices. Boolean data are provided with <3 ms latency from device to device depending on network design.
- ▶ IEC 61850 Data Server. The relay equipped with embedded IEC 61850 Ethernet protocol provides data according to predefined logical node objects. Each relay supports as many as seven unbuffered MMS report client associations. Relevant Relay Word bits are available within the logical node data, so status of relay elements, inputs, outputs, or SELOGIC control equations can be monitored.
- ▶ As many as 256 virtual bits. Configure the virtual bits within GOOSE messaging to represent a variety of Boolean values available within the relay. These bits that the relay receives are available for use in SELOGIC control equations.
- ▶ As many as 64 remote analog outputs. Assign the remote analog outputs to virtually any analog quantity available in the relay. You can also use SELOGIC math variables to develop custom analog quantities for assignment as remote analog outputs. Remote analog outputs that use GOOSE messages provide peer-to-peer transmission of analog data. Each relay can receive as many as 256 remote analog inputs and use those inputs as analog quantities within SELOGIC control equations.
- ▶ IEC 61850 standard operating modes. The relay supports Test, Blocked, On, and Off. The relay also supports Simulation mode for added flexibility.

MMS File Services

This service of IEC 61850 MMS provides support for file transfers completely within an MMS session. All relay files that can be transferred via FTP can also be transferred via MMS file services.

MMS Authentication

When enabled via a setting in the Configured IED Description (CID) file, the relay requires authentication from any client requesting to initiate an MMS session.

Architect Software

Use ACCELERATOR Architect SEL-5032 Software to manage the IEC 61850 configuration for devices on the network. This Windows-based software provides easy-to-use displays for identifying and binding IEC 61850 network data among logical nodes that use IEC 61850-compliant CID files. Architect uses CID files to describe the data available in each relay.

Serial Communications MIRRORED BITS Communications

The SEL patented MIRRORED BITS technology provides bidirectional relay-to-relay digital communication.

Figure 20 shows two relays with SEL-2815 Fiber-Optic Transceivers that use MIRRORED BITS communications. MIRRORED BITS communications can operate simultaneously on any two serial ports. This bidirectional digital communication creates additional outputs (transmitted MIRRORED BITS) and additional inputs (received MIRRORED BITS) for each serial port operating in the MIRRORED BITS communications mode.

Communicated information can include digital, analog, and virtual terminal data. Virtual terminal allows operator access to remote relays through the local relay. You can use this MIRRORED BITS protocol to transfer information between stations to enhance coordination and achieve faster tripping.

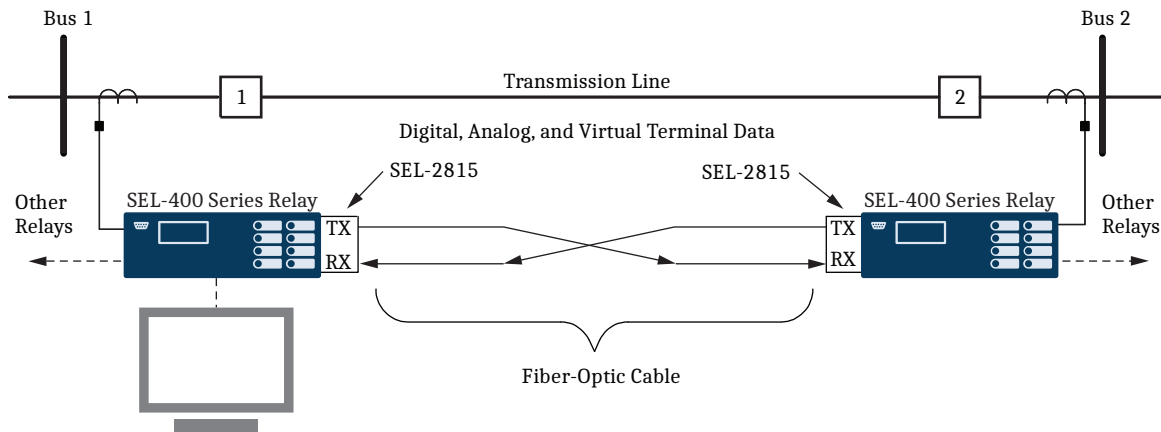

Figure 20 Integral Communication Provides Secure Protection, Monitoring, and Control as Well as Terminal Access to Both Relays Through One Connection

Open Communications Protocols

The relay does not require special communications software. ASCII terminals, printing terminals, or a computer supplied with terminal emulation and a serial communications port are all that is required. *Table 2* lists a brief description of the terminal protocols.

Table 2 Open Communications Protocol

Type	Description
ASCII	Plain-language commands for human and simple machine communications. Use for metering, setting, self-test status, event reporting, and other functions.
Compressed ASCII	Comma-delimited ASCII data reports. Allows external devices to obtain bay data in an appropriate format for direct import into spreadsheets and database programs. Data are checksum protected.
Extended Fast Meter, Fast Operate, and Fast SER	Binary protocol for machine-to-machine communications. Quickly updates communications processors, RTUs, and other substation devices with metering information, bay element, I/O status, time-tags, open and close commands, and summary event reports. Data are checksum protected. Binary and ASCII protocols operate simultaneously over the same communications lines so that control operator metering information is not lost while a technician is transferring an event report.
Ymodem	Support for reading event, settings, and oscillography files.
Optional DNP3 Level 2 Outstation	DNP with point remapping. Includes access to metering data, protection elements, contact I/O, targets, SER, relay summary event reports, and settings groups.
IEEE C37.118	Phasor measurement protocol.
MIRRORED BITS	SEL protocol for exchanging digital and analog information among SEL relays and for use as low-speed terminal connection.
IEC 61850	Ethernet-based international standard for interoperability between intelligent devices in a substation.
PRP	PRP provides redundant Ethernet network capabilities for seamless operation in the event of loss to one network.
SNTP	Ethernet-based SNTP for time synchronization among relays.
FTP and Telnet	Use Telnet to establish a terminal-to-relay connection over Ethernet. Use FTP to move files in and out of the relay over Ethernet.

Automation

Flexible Control Logic and Integration Features

Use the control logic to perform the following:

- Replace traditional panel control switches
- Eliminate remote terminal unit (RTU)-to-bay wiring
- Replace traditional latching relays
- Replace traditional indicating panel lights

Eliminate traditional panel control switches with 64 local control points. Set, clear, or pulse local control points with the front-panel pushbuttons and display. Program the local control points to implement your control scheme via SELOGIC control equations. Use the local control points for such functions as trip testing, enabling/disabling reclosing, and tripping/closing circuit breakers.

Eliminate RTU-to-bay wiring with 64 remote control points per relay. Set, clear, or pulse remote control points via serial port commands. Incorporate the remote control points into your control scheme via SELOGIC control equations. Use remote control points for SCADA-type control operations (e.g., trip, close, settings group selection).

Replace traditional latching relays for such functions as remote control enable with 64 latching control points. Program latch set and latch reset conditions with SELOGIC control equations. Set or reset the latch control points via

control inputs, remote control points, local control points, or any programmable logic condition. The relay retains the states of the latch control points after turning on following a power interruption.

Replace traditional indicating panel lights and switches with as many as 24 latching target LEDs and as many as 12 programmable pushbuttons with LEDs. Define custom messages (i.e., BREAKER OPEN, BREAKER CLOSED, RECLOSER ENABLED) to report power system or relay conditions on the large format LCD. Control displayed messages with SELOGIC control equations by driving the LCD via any logic point in the relay.

SELOGIC Control Equations With Expanded Capabilities and Aliases

Expanded SELOGIC control equations put relay logic in the hands of the engineer. Assign inputs to suit your application, logically combine selected bay elements for various control functions, and assign outputs to your logic functions.

Programming SELOGIC control equations consists of combining relay elements, inputs, and outputs with SELOGIC control equation operators (*Table 3*). Any element in the Relay Word can be used in these equations. For complex or unique applications, these expanded SELOGIC functions allow superior flexibility.

Table 3 SELOGIC Control Equation Operators

Operator Type	Operators	Comments
Boolean	AND, OR, NOT	Allows combination of measuring units.
Edge Detection	F_TRIG, R_TRIG	Operates at the change of state of an internal function.
Comparison	>, >=, =, <=, <, <>	
Arithmetic	+, -, *, /	Uses traditional math functions for analog quantities in an easily programmable equation.
Numerical	ABS, SIN, COS, LN, EXP, SQRT, LOG	
Precedence Control	()	Allows multiple and nested sets of parentheses.
Comment	#, (* *)	Provides for easy documentation of control and protection logic.

Use the relay alias capability to assign more meaningful names to analog and Boolean quantities. This improves the readability of customized programming. Use as many as 200 aliases to rename any digital or analog quantity. The following is an example of possible applications of SELOGIC control equations that use aliases.

```
==>SET T <Enter>
1: PMV01,THETA
```

(assign the alias "THETA" to math variable PMV01)

```
2: PMV02,TAN
```

(assign the alias "TAN" to math variable PMV02)

```
==>SET L <Enter>
```

```
1: # CALCULATE THE TANGENT OF THETA
2: TAN:=SIN(THETA)/COS(THETA)
```

(use the aliases in an equation)

Add programmable control functions to your relay and automation systems. New functions and capabilities enable using analog values in conditional logic statements. The following are examples of possible applications of SELOGIC control equations with expanded capabilities.

- ▶ Emulate a motor-driven reclose timer, including stall, reset, and drive-to-lockout conditions.
- ▶ Scale analog values for SCADA retrieval.
- ▶ Initiate remedial action sequence based on load flow before fault conditions.
- ▶ Interlock breakers and disconnect switches.
- ▶ Restrict breaker tripping in excessive duty situations without additional relays.
- ▶ Hold momentary change-of-state conditions for SCADA polling.

Metering and Monitoring

Access a range of useful information in the relay with the metering function. Metered quantities include fundamental primary and secondary current and voltage magnitudes and angles for each terminal. RMS voltage and

current metering is also provided. Fundamental phase and real and reactive power, per-phase voltage magnitude, angle, and frequency are displayed in the metering report for applications that use the relay voltage inputs.

Table 4 Metering Capabilities

Capabilities	Description
Instantaneous Quantities	
Voltages V _{A, B, C} (Y), V _{A, B, C} (Z), V _{φφ} , 3V ₀ , V ₁ , 3V ₂	0–300 V with phase quantities for each of the six voltage sources available as a separate quantity.
Currents I _{A, B, C} (W), I _{A, B, C} (X), I _A L, I _B L, I _C L, (combined currents) I _{GL} , I _{IL} , 3I _{2L} (combined currents)	Phase quantities for each of the two current sources available as a separate quantity or combined as line quantities.
Differential Metering	
Currents I _{A, B, C} , I ₁ , 3I ₂ , 3I ₀	Local terminal/all Remote Terminals
Differential Current I _{A, B, C} , I ₁ , 3I ₂ , 3I ₀	Local terminal/all Remote terminals
Alpha Plane k alpha	Alpha plane ratio Alpha plane angle
Power/Energy Metering Quantities	
MW, MWh, MVAR, MVARh, MVA, PF, single-phase and three-phase	Available for each input set and as combined quantities for the line.
Demand/Peak Demand Metering	
I _{A, B, C} , 3I ₂ , 3I ₀	Thermal or rolling interval demand and peak demand.
MW, MVAR, MVA, single-phase	Thermal or rolling interval demand and peak demand.
MW, MVAR, MVA, three-phase	Thermal or rolling interval demand and peak demand.
Synchrophasors	
Voltages (Primary Magnitude, Angle) V _{A, B, C} (Y), V _{A, B, C} (Z)	Primary phase quantities (kV) for each of the six voltage sources available.
Currents I _{A, B, C} (W), I _{A, B, C} (X)	Primary phase quantities (A) for each of the six voltage sources available.
Frequency FREQ dF/dT	Frequency (Hz) as measured by frequency source potential inputs. Rate-of-change in frequency (Hz/s).

Event Reporting and SER

Event reports and SER features simplify post-fault analysis and help improve your understanding of both simple and complex protective scheme operations. These features also aid in testing and troubleshooting relay settings and protective schemes.

Oscillography and Event Reporting

In response to a user-selected internal or external trigger, the voltage, current, and element status information contained in each event report confirms relay, scheme, and system performance for every fault. The relay provides sampling rates as fast as 8 kHz for analog quantities in a COMTRADE file format, as well as eight-sample-per-cycle and four-sample-per-cycle event reports. The relay stores as much as 3 seconds of 8 kHz event data. The relay supports inclusion of user-configurable analogs in the events. Reports are stored in nonvolatile memory. Relay settings operational in the relay at the time of the event are appended to each event report.

Each relay provides event reports for analysis with software such as SEL-5601-2 SYNCHROWAVE[®] Event Software. With SYNCHROWAVE Event, you can display events from several relays to make the fault analysis easier and more meaningful. Because the different relays time-stamp the events with values from their individual clocks, be sure to time synchronize the relay with an IRIG-B clock input or PTP source to use this feature.

Event Summary

Each time the relay generates a standard event report, it also generates a corresponding event summary. This is a concise description of an event that includes the following information:

- Relay/terminal identification
- Event date and time
- Event type
- Event number
- Time source
- Active settings group
- Targets asserted during the fault
- Current magnitudes and angles for each terminal
- Pre-fault and fault calculated zero- and negative-sequence currents
- Voltage magnitudes and angles

- Terminals tripped for this fault
- Recloser shot count at time of trigger (if applicable)
- Fault location (if applicable)
- Breaker status (open/close)

With an appropriate setting, the relay sends an event summary in ASCII text automatically to one or more serial ports each time an event report is triggered.

SER

Use this feature to gain a broad perspective of relay element operation. Items that trigger an SER entry are selectable and can include as many as 250 monitoring points, such as I/O change-of-state and element pickup/dropout. The relay SER stores the latest 1000 events.

Analog Signal Profiling

The relay provides analog signal profiling for as many as 20 analog quantities. Select any analog quantity measured or calculated by the relay for analog signal profiling. You can select signal sampling rates of 1, 5, 15, 30, and 60 minutes through settings. The analog signal profile report provides a comma-separated variable (CSV) list that you can load into any spreadsheet or database for analysis and graphical display.

SELOGIC enable/disable functions can start and stop signal profiling based on Boolean or analog comparison conditions.

Substation Battery Monitor for DC Quality Assurance

The relay measures and reports the substation battery voltage for up to two battery systems. The SEL-411L, SEL-421, SEL-451 support two battery monitors while the SEL-487B, SEL-487E, and SEL-487V support one. Each battery monitor supports programmable threshold comparators and associated logic provides alarm and control for batteries and chargers. The relay also provides dual ground detection. Monitor dc system status alarms with an SEL communications processor and trigger messages, telephone calls, or other actions.

The measured dc voltage is reported in the METER display via serial port communications, on the LCD, and in the event report. Use the event report data to see an oscillographic display of the battery voltage. Monitor the substation battery voltage drops during trip, close, and other control operations.

Breaker Contact Wear Monitoring

Circuit breakers experience mechanical and electrical wear during each operation. Effective scheduling of breaker maintenance takes into account the manufacturer’s published data of contact wear versus interruption levels and operation count.

- ▶ Every time the breaker trips, the relay integrates interrupted current. When the result of this integration exceeds the threshold set by the breaker wear curve (Figure 21), the relay can alarm via an output contact or the optional front-panel display. With this information, you can schedule breaker maintenance in a timely, economical fashion.
- ▶ The relay monitors last and average mechanical and electrical interruption time per pole. You can easily determine if operating time is increasing beyond reasonable tolerance and then schedule proactive breaker maintenance. You can activate an alarm point if operation time exceeds a preset value.

The relay also monitors breaker motor run time, pole discrepancy, and breaker inactivity.

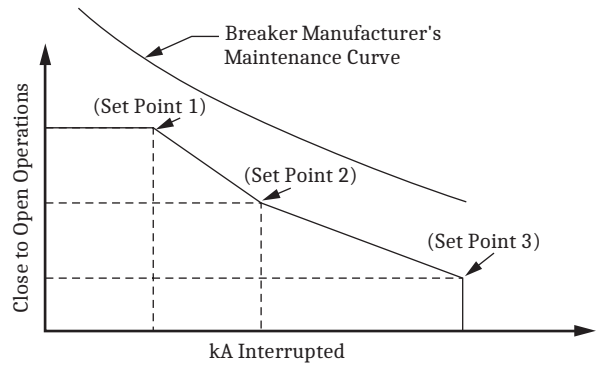

Figure 21 Breaker Contact Wear Curve and Settings

Diagrams and Dimensions

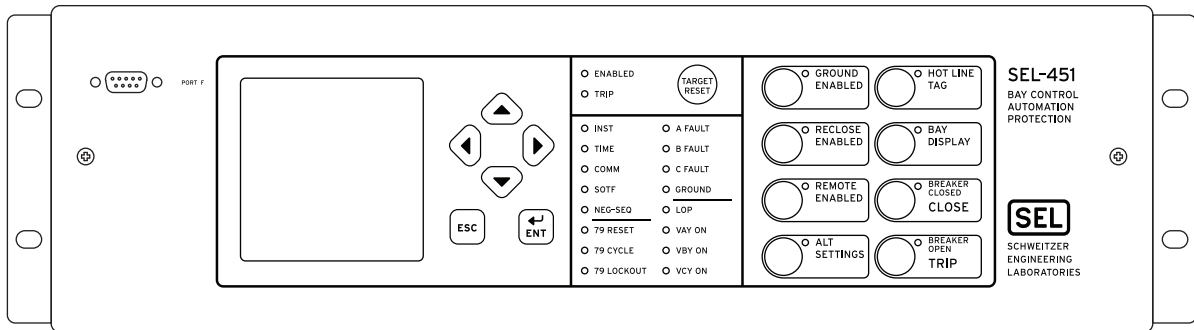

Figure 22 3U Front Panel, Rack-Mount Option With Standard HMI and Optional Bay Control Overlay

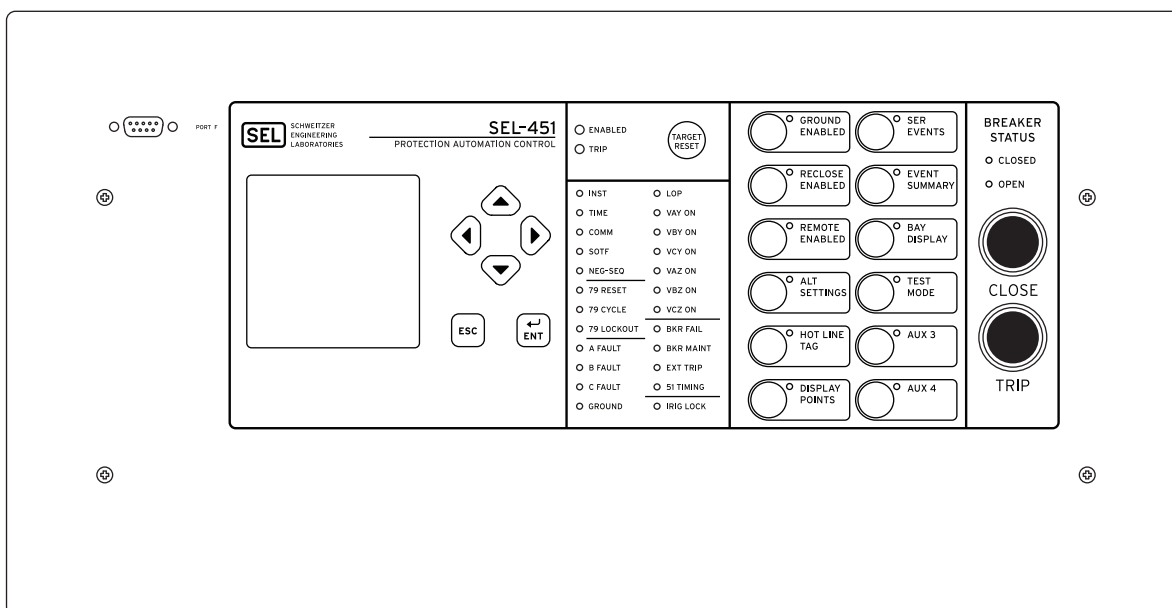
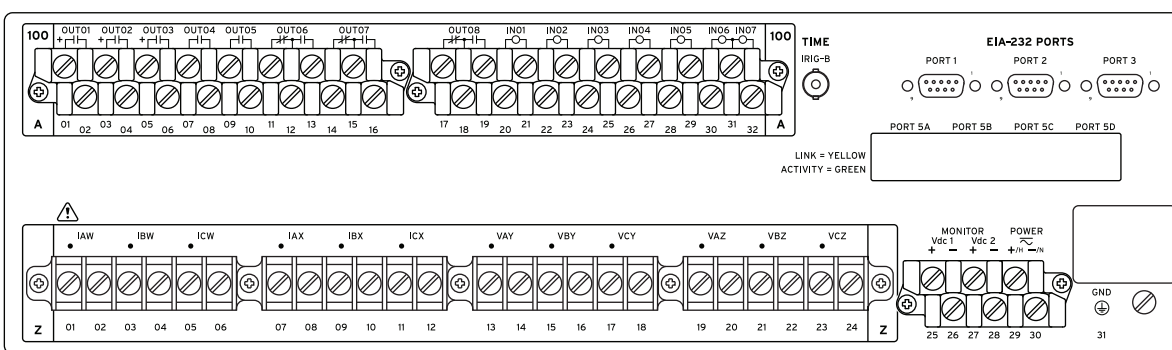
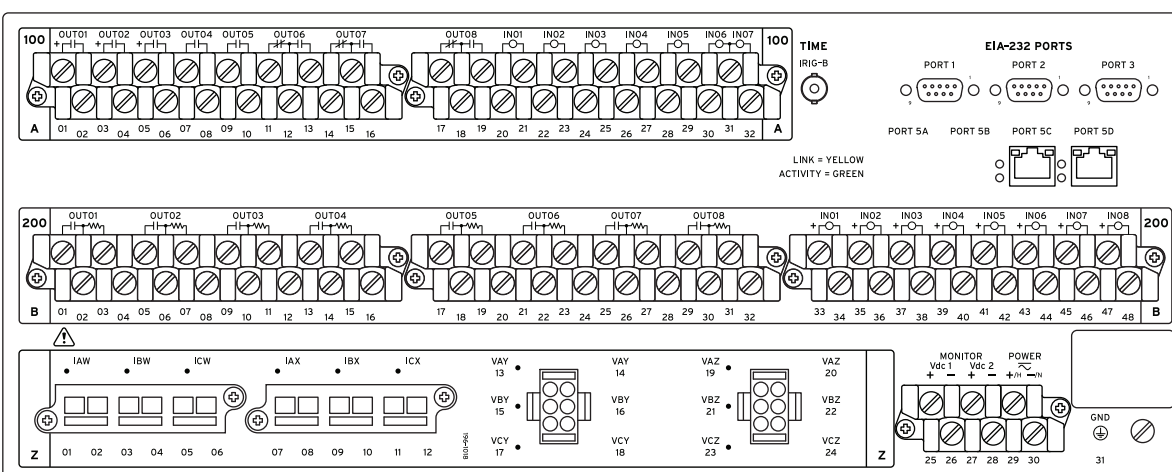

Figure 23 5U Front Panel, Panel-Mount Option With Extended HMI and Optional Trip/Close Pushbuttons



17014c

Figure 24 3U Rear Panel, Main Board With Terminal Block



17015c

Figure 25 4U Rear Panel, Main Board, Connectorized® Option With One (INT5) I/O Board

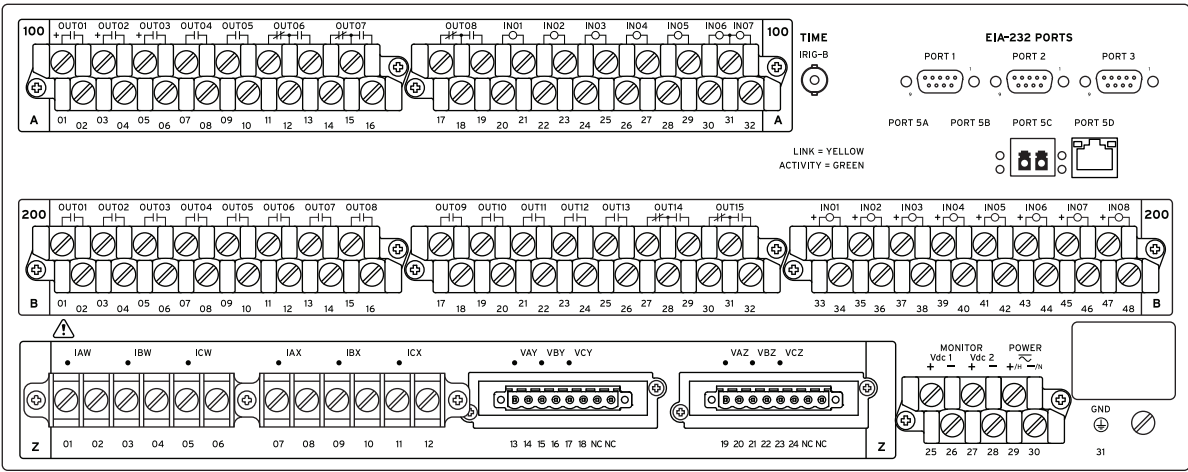

i7015c

Figure 26 4U Rear Panel, Main Board, LEA Voltage Option With One (INT1) I/O Board

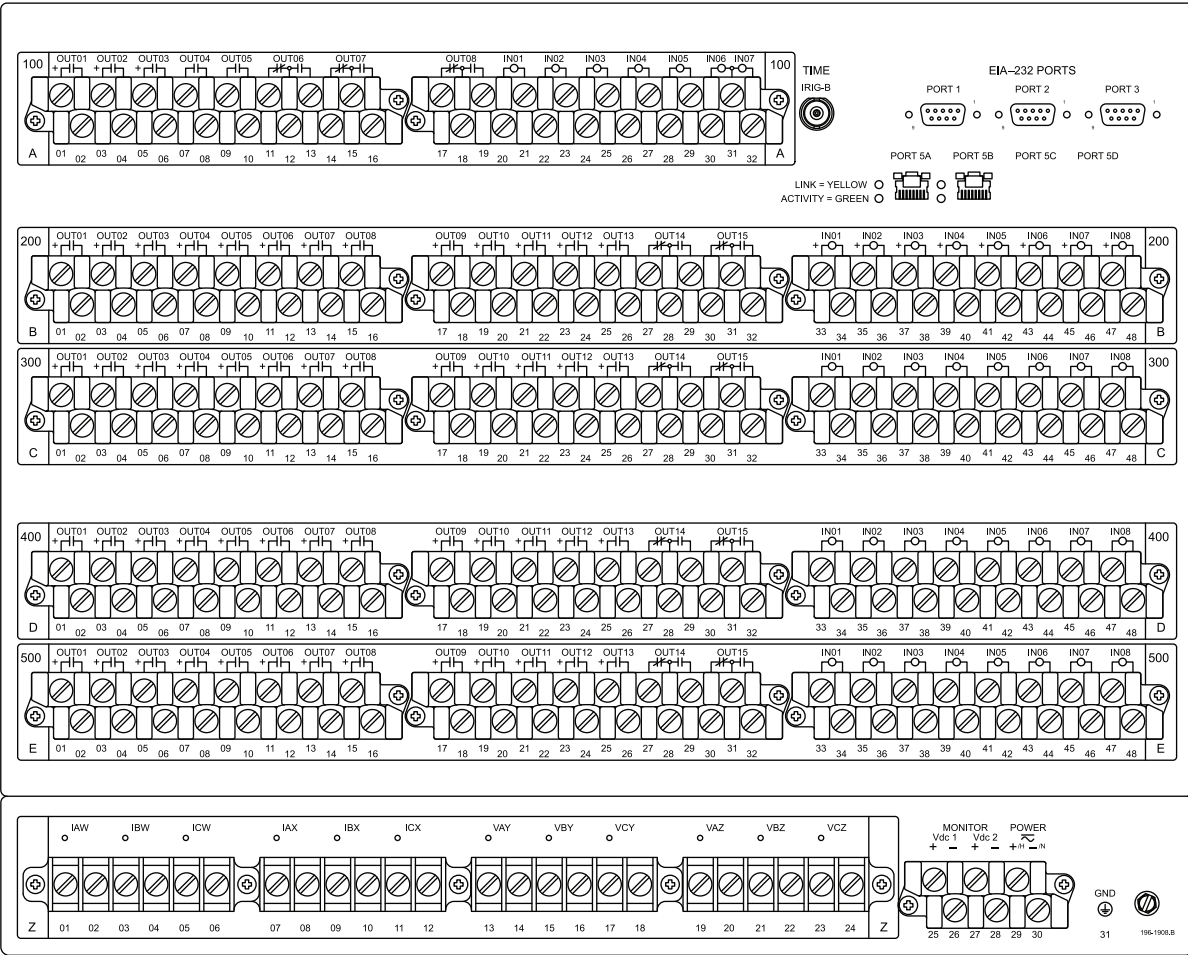

i7155a

Figure 27 8U Rear Panel, Main Board, Terminal Block Option With Four (One INT6 and Three INT7) I/O Boards

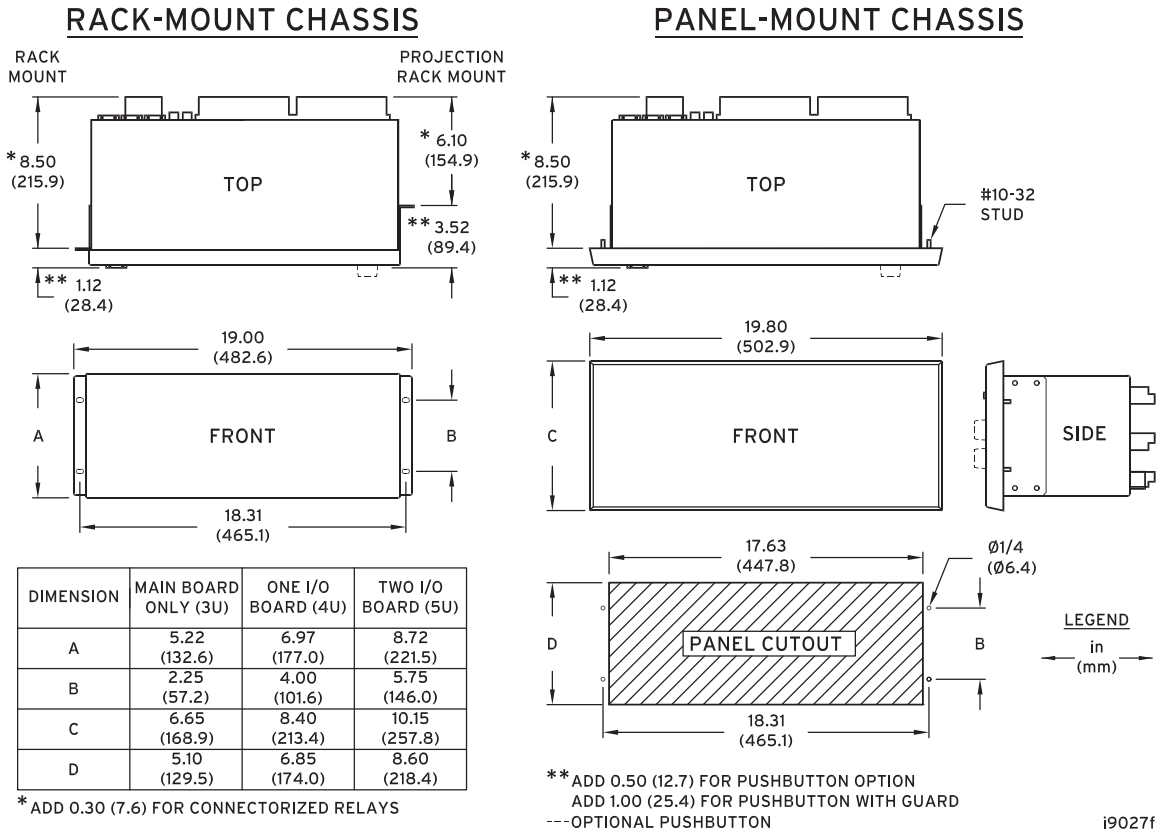

(Horizontal Mounting Shown; Dimensions Also Apply to Vertical Mounting)

Figure 28 SEL-451 3U, 4U, and 5U Dimensions for Rack- and Panel-Mount Models

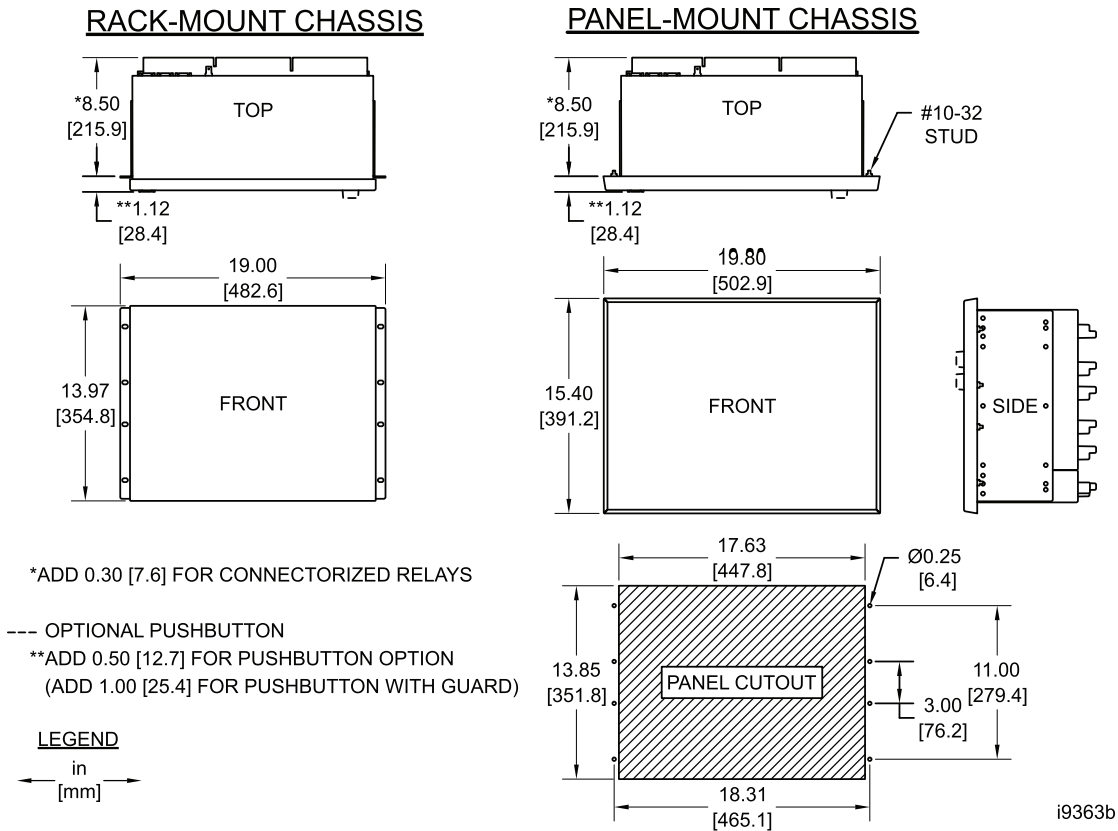

Figure 29 SEL-451 8U Dimensions for Rack- and Panel-Mount Models

Models and Options

The SEL-451 allows you to simplify procurement, protection engineering, panel design and manufacturing, and spare part management. This data sheet is applicable to the SEL-451-5 and -A relays. Not all the features, functions, and applications detailed in this data sheet apply to all variants of the SEL-451. *Table 6* details which features, functions, and applications are supported by each of the SEL-451 models.

NOTE: I/O boards in 400 and 500 I/O board positions operate at the main-board input voltage. For more information, see the ordering information provided on the product webpage.

Consider the following options when ordering and configuring the relay.

- Firmware options
 - See *Table 6*
- Chassis size
 - 3U, 4U, 5U, and 8U (U is one rack unit—44.45 mm or 1.75 in)

Table 5 Interface Board Information (Sheet 1 of 2)

Board Name	Inputs	Description	Outputs	Description
INT1	8	Independent, programmable pickup	13 2	Standard Form A Standard Form C
INT2	8	Optoisolated, independent, level-sensitive	13 2	Standard Form A Standard Form C
INT3	18 6	Two sets of 9 common optoisolated, level-sensitive Optoisolated, independent, level-sensitive	4	High-current interrupting, Form A
INT4	18 6	Two sets of 9 common optoisolated, level-sensitive Optoisolated, independent, level-sensitive	6 2	High-speed, high-current interrupting, Form A Standard Form A

Table 5 Interface Board Information (Sheet 2 of 2)

Board Name	Inputs	Description	Outputs	Description
INT5		Independent, programmable pickup	8	High-speed, high-current interrupting, Form A
INT6	8	Independent, programmable pickup	13 2	High-current interrupting, Form A Standard Form C
INT7	8	Optoisolated, independent, level-sensitive	13 2	High-current interrupting, Form A Standard Form C

- Chassis orientation and type
 - Horizontal rack mount
 - Horizontal panel mount
 - Vertical rack mount
 - Vertical panel mount
- Power supply
 - 24–48 Vdc
 - 48–125 Vdc or 110–120 Vac
 - 125–250 Vdc or 110–240 Vac
- Secondary inputs
 - 1 A nominal or 5 A nominal CT inputs
 - 300 V phase-to-neutral wye configuration PT inputs
 - Two three-phase, 8 Vac, C37.92-compliant LEA inputs
- Ethernet card options
 - Ethernet card with combinations of 10/100BASE-T and 100BASE-FX media connections on each of two ports
- Communications protocols
 - Complete group of SEL protocols (SEL ASCII, SEL Compressed ASCII, SEL Settings File Transfer, SEL Fast Meter, SEL Fast Operate, SEL Fast SER, RTDs, Enhanced MIRRORING BITS Communications), FTP, Telnet, DNP3 LAN/WAN, and Synchrophasors (SEL Fast Message and IEEE C37.118 format).
 - Above protocols, plus IEC 61850 Edition 2.
- Connector type
 - Screw terminal block inputs
 - Connectorized
- Bay Control overlay
 - The standard relay front overlay indicates “Protection, Automation Control”. If the relay is used specifically for bay control purposes, an optional front-panel overlay with “Bay Control Protection Control” is available.

Contact the SEL factory or your local Technical Service Center for particular part number and ordering information (see *Technical Support on page 30*). You can also view the latest part number and ordering information on the SEL website at selinc.com.

Table 6 shows the firmware options available in the SEL-451-5 and SEL-451-A models.

Table 6 Firmware Options Available in the SEL-451-5 and SEL-451-A Models^a (Sheet 1 of 3)

SEL-451 Firmware Options	SEL-451-5	SEL-451-A
Applications		
Protection and Control		
Single Breaker	•	•
Dual Breaker	•	
Directional Overcurrent Feeder Protection	•	•
Pilot Protection—Directional comparison Schemes	•	•
Major Protection Functions		
Overcurrent (Phase, Negative-Sequence, Zero-Sequence)	•	•
Directional (Phase, Negative-Sequence, Zero-Sequence)	•	•
Breaker Failure		
Single Breaker	•	•
Dual Breaker	•	
Over- and Undervoltage	•	•

Table 6 Firmware Options Available in the SEL-451-5 and SEL-451-A Models^a (Sheet 2 of 3)

SEL-451 Firmware Options	SEL-451-5	SEL-451-A
Over- and Underpower	•	•
Over- and Underfrequency	•	•
IEC Thermal	•	•
Harmonic Blocking	•	•
High-Impedance Fault Detection—Arc Sense™ Technology (AST)	*	*
Supervisory Elements		
Loss of Potential	•	•
Load Encroachment	•	•
Synchronism Check	•	•
Control		
Automatic Reclosing		
Single Breaker	•	•
Dual Breaker	•	
Single Line Diagram	•	•
Freeform SELOGIC Control Equations	•	•
Nonvolatile Latch Control Switches	•	•
Programmable Math Operators	•	•
Fault Locating, Monitor, and Recording		
Single-Ended Impedance Fault Location	•	•
Breaker Wear Monitor		
Single Breaker	•	•
Dual Breaker	•	
Event Recording (DFR)	•	•
Sequential Event Recording (SER)	•	•
High-Accuracy Metering	•	•
Voltage Sag, Swell, Interruption (VSSI) Reporting	•	•
DC Battery Monitor		
Single Battery	•	•
Dual Battery	•	
Voltage Sag, Swell Monitor	•	•
SCADA/HMI Integration and Protocols		
SEL ASCII, Fast Meter, Fast SER	•	•
DNP3—Serial	•	•
DNP3 LAN/WAN	•	•
Synchrophasors (IEEE C37.118)	•	
IEC 61850 Edition 2.0	*	•
Parallel Redundancy Protocol (PRP)	*	•
IEEE 1588 Precision Time Protocol Version 2 (PTPv2)	*	*
SEL MIRRORRED BITS Communications	•	•
Miscellaneous		
High-Speed High-Current Interrupting Output Contacts	*	*
Software Invertible CT and PT Polarities	•	•
Configurable Display Points	•	•

Table 6 Firmware Options Available in the SEL-451-5 and SEL-451-A Models^a (Sheet 3 of 3)

SEL-451 Firmware Options	SEL-451-5	SEL-451-A
Configurable Pushbuttons	•	•
Configurable Targets	•	•
Printable Labels	•	•

^a • = Standard feature

* = Optional feature

Specifications

Note: TiDL (EtherCAT) technology is no longer offered in the SEL-451-5, -A. TiDL (T-Protocol) is available in the SEL-451-6. If the relay is using a TiDL (EtherCAT), the operating times will be delayed by 1.5 ms. Use caution when setting the relay coordination times to account for this added delay. Element operate times will also have this small added delay.

Compliance

Designed and manufactured under an ISO 9001 certified quality management system

FCC Compliance Statement

This equipment has been tested and found to comply with the limits for a Class A digital device, pursuant to part 15 of the FCC Rules. These limits are designed to provide reasonable protection against harmful interference when the equipment is operated in a commercial environment. This equipment generates, uses, and can radiate radio frequency energy and, if not installed and used in accordance with the instruction manual, may cause harmful interference in which case the user will be required to correct the interference at his own expense.

UL Listed to U.S. and Canadian safety standards (File E212775; NRGU, NRGU7)

CE Mark

General

AC Analog Inputs

Sampling Rate: 8 kHz

AC Current Input (Secondary Circuits)

Note: Current transformers are Measurement Category II.

Current Rating (With DC Offset at X/R = 10, 1.5 cycles)

1 A Nominal: 18.2 A

5 A Nominal: 91 A

Continuous Thermal Rating

1 A Nominal: 3 A
4 A (+55°C)

5 A Nominal: 15 A
20 A (+55°C)

Saturation Current (Linear) Rating

1 A Nominal: 20 A

5 A Nominal: 100 A

A/D Current Limit

Note: Signal clipping may occur beyond this limit.

1 A Nominal: 49.5 A

5 A Nominal: 247.5 A

One-Second Thermal Rating

1 A Nominal: 100 A

5 A Nominal: 500 A

One-Cycle Thermal Rating

1 A Nominal: 250 A peak

5 A Nominal: 1250 A peak

Burden Rating

1 A Nominal: ≤ 0.1 VA @ 1 A

5 A Nominal: ≤ 0.5 VA @ 5 A

AC Voltage Inputs

Three-phase, four-wire (wye) connections are supported.

Rated Voltage Range: 55–250 V_{LN}

Operational Voltage Range: 0–300 V_{LN}

Ten-Second Thermal Rating: 600 Vac

Burden: ≤ 0.1 VA @ 125 V

LEA Voltage Inputs

Rated Voltage Range: 4 V_{L-N}

Operational Voltage Range: 0–8 V_{L-N}

Ten-Second Thermal Rating: 300 Vac

Input Impedance: 1 MΩ

Common Mode Voltage

Operation: 50 Vac

Without Damage: 300 Vac

Frequency and Rotation

Nominal Frequency Rating: 50 ±5 Hz
60 ±5 Hz

Phase Rotation: ABC or ACB

Frequency Tracking Range: 40–65 Hz
< 40 Hz = 40 Hz
> 65 Hz = 65 Hz

Default Slew Rate: 15 Hz/s

Power Supply

24–48 Vdc

Rated Voltage: 24–48 Vdc

Operational Voltage Range: 18–60 Vdc

Vdc Input Ripple: 15% per IEC 60255-26:2013

Interruption: 20 ms at 24 Vdc, 100 ms at 48 Vdc per IEC 60255-26:2013

Burden: < 35 W

48–125 Vdc or 110–120 Vac

Rated Voltage: 48–125 Vdc, 110–120 Vac

Operational Voltage Range: 38–140 Vdc
85–140 Vac

Rated Frequency: 50/60 Hz

Operational Frequency Range: 30–120 Hz

Vdc Input Ripple: 15% per IEC 60255-26:2013

Interruption: 14 ms at 48 Vdc, 160 ms at 125 Vdc per IEC 60255-26:2013

Burden: < 35 W, < 90 VA

125–250 Vdc or 110–240 Vac

Rated Voltage:	125–250 Vdc, 110–240 Vac
Operational Voltage Range:	85–300 Vdc 85–264 Vac
Rated Frequency:	50/60 Hz
Operational Frequency Range:	30–120 Hz
Vdc Input Ripple:	15% per IEC 60255-26:2013
Interruption:	46 ms at 125 Vdc, 250 ms at 250 Vdc per IEC 60255-26:2013
Burden:	< 35 W, < 90 VA

Control Outputs**Note:** IEEE C37.90-2005 and IEC 60255-27:2013

Update Rate:	1/8 cycle
Make (Short Duration Contact Current):	30 Adc 1,000 operations at 250 Vdc 2,000 operations at 125 Vdc
Limiting Making Capacity:	1000 W at 250 Vdc (L/R = 40 ms)
Mechanical Endurance:	10,000 operations

Standard

Rated Voltage:	24–250 Vdc 110–240 Vrms
Operational Voltage Range:	0–300 Vdc 0–264 Vrms
Operating Time:	Pickup ≤ 6 ms (resistive load) Dropout ≤ 6 ms (resistive load)
Short-Time Thermal Withstand:	50 A for 1 s
Continuous Contact Current:	6 A at 70°C 4 A at 85°C
Contact Protection:	MOV protection across open contacts 264 Vrms continuous voltage 300 Vdc continuous voltage
Limiting Breaking Capacity/Electrical Endurance:	10,000 operations 10 operations in 4 seconds, followed by 2 minutes idle

Rated Voltage	Resistive Break	Inductive Break L/R = 40 ms (DC) PF = 0.4 (AC)
24 Vdc	0.75 Adc	0.75 Adc
48 Vdc	0.63 Adc	0.63 Adc
125 Vdc	0.30 Adc	0.30 Adc
250 Vdc	0.20 Adc	0.20 Adc
110 Vrms	0.30 Arms	0.30 Arms
240 Vrms	0.20 Arms	0.20 Arms

Hybrid (High-Current Interrupting)

Rated Voltage:	24–250 Vdc
Operational Voltage Range:	0–300 Vdc
Operating Time:	Pickup ≤ 6 ms (resistive load) Dropout ≤ 6 ms (resistive load)
Short-Time Thermal Withstand:	50 Adc for 1 s
Continuous Contact Current:	6 Adc at 70°C 4 Adc at 85°C

Contact Protection:	MOV protection across open contacts 300 Vdc continuous voltage
Limiting Breaking Capacity/Electrical Endurance:	10,000 operations 4 operations in 1 second, followed by 2 minutes idle

Rated Voltage	Resistive Break	Inductive Break
24 Vdc	10 Adc	10 Adc (L/R = 40 ms)
48 Vdc	10 Adc	10 Adc (L/R = 40 ms)
125 Vdc	10 Adc	10 Adc (L/R = 40 ms)
250 Vdc	10 Adc	10 Adc (L/R = 20 ms)

Note: Do not use hybrid control outputs to switch ac control signals. These outputs are polarity-dependent.**Fast Hybrid (High-Speed High-Current Interrupting)**

Rated Voltage:	24–250 Vdc
Operational Voltage Range:	0–300 Vdc
Operating Time:	Pickup ≤ 10 μs (resistive load) Dropout ≤ 8 ms (resistive load)

Short-Time Thermal Withstand:	50 Adc for 1 s
Continuous Contact Current:	6 Adc at 70°C 4 Adc at 85°C
Contact Protection:	MOV protection across open contacts 300 Vdc continuous voltage
Limiting Breaking Capacity/Electrical Endurance:	10,000 operations 4 operations in 1 second, followed by 2 minutes idle

Rated Voltage	Resistive Break	Inductive Break
24 Vdc	10 Adc	10 Adc (L/R = 40 ms)
48 Vdc	10 Adc	10 Adc (L/R = 40 ms)
125 Vdc	10 Adc	10 Adc (L/R = 40 ms)
250 Vdc	10 Adc	10 Adc (L/R = 20 ms)

Note: Do not use hybrid control outputs to switch ac control signals.**Auxiliary Breaker Control Pushbuttons**

Quantity:	2
Pushbutton Functions:	One (1) pushbutton shall be provided to open the breaker. One (1) pushbutton shall be provided to close the breaker.

Resistive DC or AC Outputs With Arc Suppression Disabled

Make:	30 A per IEEE C37.90-2005
Carry:	6 A continuous carry
1 s Rating:	50 A
MOV Protection:	250 Vac/330 Vdc/130 J

Breaking Capacity (10,000 Operations):

Rated Voltage	Resistive Break	Inductive Break
48 Vdc	0.50 A	0.50 A (L/R = 40 ms)
125 Vdc	0.30 A	0.30 A (L/R = 40 ms)
250 Vdc	0.20 A	0.20 A (L/R = 20 ms)

High-Interrupt DC Outputs With Arc Suppression Enabled

Make:	30 A per IEEE C37.90-2005
Carry:	6 A continuous carry
1 s Rating:	50 A
MOV Protection:	330 Vdc/130 J

Breaking Capacity (10,000 Operations):

Rated Voltage	Resistive Break	Inductive Break
48 Vdc	10 A	10 A (L/R = 40 ms)
125 Vdc	10 A	10 A (L/R = 40 ms)
250 Vdc	10 A	10 A (L/R = 20 ms)

Breaker Open/Closed LEDs:

48 Vdc: on for 30–60 Vdc;
125 Vdc: on for 80–150 Vdc; 96–144 Vac
250 Vdc: on for 150–300 Vdc; 192–288 Vac

Note: With nominal control voltage applied, each LED draws 8 mA (max.). Jumpers may be set to 125 Vdc for 110 Vdc input and set to 250 Vdc for 220 Vdc input.

Control Inputs

Direct Coupled (Use With DC Signals)

INT1, INT5, and INT6
Interface Boards: 8 inputs with no shared terminals
Range: 15–265 Vdc, independently adjustable
Accuracy: $\pm 5\% \pm 3$ Vdc
Maximum Voltage: 300 Vdc
Sampling Rate: 2 kHz
Typical Burden: 0.24 W @ 125 Vdc

Optoisolated (Use With AC or DC Signals)

Main Board: 5 inputs with no shared terminals
2 inputs with shared terminals
INT2, INT7, and INT8
Interface Boards: 8 inputs with no shared terminals
INT3 and INT4
Interface Boards: 18 inputs with no shared terminals
(2 groups of 9 inputs, with each group sharing one terminal)
Voltage Options: 24 V standard
48, 110, 125, 220, 250 V level sensitive
Current Drawn: < 5 mA at nominal voltage
< 8 mA for 110 V option
Sampling Rate: 2 kHz

DC Thresholds

(Dropout thresholds indicate level-sensitive option.)

24 Vdc: Pickup 19.2–30.0 Vdc
Dropout < 14.4 Vdc
48 Vdc: Pickup 38.4–60.0 Vdc;
Dropout < 28.8 Vdc
110 Vdc: Pickup 88.0–132.0 Vdc;
Dropout < 66.0 Vdc
125 Vdc: Pickup 105–150 Vdc;
Dropout < 75 Vdc
220 Vdc: Pickup 176–264 Vdc;
Dropout < 132 Vdc
250 Vdc: Pickup 200–300 Vdc;
Dropout < 150 Vdc

AC Thresholds

(Ratings met only when recommended control input settings are used)

24 Vac: Pickup 16.4–30.0 Vac rms
Dropout < 14.4 Vdc
48 Vac: Pickup 32.8–60.0 Vac rms;
Dropout < 20.3 Vac rms
110 Vac: Pickup 75.1–132.0 Vac rms;
Dropout < 46.6 Vac rms
125 Vac: Pickup 89.6–150.0 Vac rms;
Dropout < 53.0 Vac rms

220 Vac: Pickup 150.3–264 Vac rms;
Dropout < 93.2 Vac rms

250 Vac: Pickup 170.6–300 Vac rms;
Dropout < 106 Vac rms

Communications Ports

EIA-232: 1 Front and 3 Rear
Serial Data Speed: 300–57600 bps

Communications Card Slot for Optional Ethernet Card

Ordering Options: 10/100BASE-T
Connector Type: RJ45
Ordering Option: 100BASE-FX Fiber-Optic
Connector Type: LC
Fiber Type: Multimode
Wavelength: 1300 nm
Source: LED
Min. TX Power: –19 dBm
Max. TX Power: –14 dBm
RX Sensitivity: –32 dBm
Sys. Gain: 13 dB

Communications Ports for Optional TiDL (EtherCAT) Interface

EtherCAT Fiber-Optic Ports: 8
Data Rate: Automatic
Connector Type: LC fiber
Protocols: Dedicated EtherCAT
Class 1 LASER/LED
Wavelength: 1300 nm
Fiber Type: Multimode
Link Budget: 11 dB
Min. TX Power: –20 dBm
Min. RX Sensitivity: –31 dBm
Fiber Size: 50–200 μ m
Approximate Range: 2 km
Data Rate: 100 Mbps
Typical Fiber Attenuation: –2 dB/km

Time Inputs

IRIG Input–Serial Port 1

Input: Demodulated IRIG-B
Rated I/O Voltage: 5 Vdc
Operating Voltage Range: 0–8 Vdc
Logic High Threshold: ≥ 2.8 Vdc
Logic Low Threshold: ≤ 0.8 Vdc
Input Impedance: 2.5 k Ω

IRIG-B Input–BNC Connector

Input: Demodulated IRIG-B
Rated I/O Voltage: 5 Vdc
Operating Voltage Range: 0–8 Vdc
Logic High Threshold: ≥ 2.2 Vdc
Logic Low Threshold: ≤ 0.8 Vdc
Input Impedance: >1 k Ω
Dielectric Test Voltage: 0.5 kVac

PTP–Ethernet Port 5A, 5B

Input:	IEEE 1588 PTPv2
Profiles:	Default, C37.238-2011 (Power Profile), IEC/IEEE 61850-9-3-2016 (Power Utility Automation Profile)
Synchronization Accuracy:	±100 ns @ 1-second synchronization intervals when communicating directly with master clock

Operating Temperature

–40° to +85°C (–40° to +185°F)

Note: LCD contrast impaired for temperatures below –20° and above +70°C.
Stated temperature ranges not applicable to UL applications.

Humidity

5% to 95% without condensation

Weight (Maximum)

3U Rack Unit:	8.0 kg (17.7 lb)
4U Rack Unit:	9.8 kg (21.6 lb)
5U Rack Unit:	11.6 kg (25.6 lb)
8U Rack Unit:	14.0 kg (32.8 lb)

Terminal Connections

Rear Screw-Terminal Tightening Torque, #8 Ring Lug

Minimum:	1.0 Nm (9 in-lb)
Maximum:	2.0 Nm (18 in-lb)

User terminals and stranded copper wire should have a minimum
temperature rating of 105°C. Ring terminals are recommended.

Wire Sizes and Insulation

Wire sizes for grounding (earthing), current, voltage, and contact
connections are dictated by the terminal blocks and expected load
currents. You can use the following table as a guide in selecting wire sizes.
The grounding conductor should be as short as possible and sized equal to or
greater than any other conductor connected to the device, unless otherwise
required by local or national wiring regulations.

Connection Type	Min. Wire Size	Max. Wire Size
Grounding (Earthing) Connection	14 AWG (2.5 mm ²)	N/A
Current Connection	16 AWG (1.5 mm ²)	10 AWG (5.3 mm ²)
Potential (Voltage) Connection	18 AWG (0.8 mm ²)	14 AWG (2.5 mm ²)
Contact I/O	18 AWG (0.8 mm ²)	10 AWG (5.3 mm ²)
Other Connection	18 AWG (0.8 mm ²)	10 AWG (5.3 mm ²)

Type Tests**Installation Requirements**

Overvoltage Category:	2
Pollution Degree:	2

Safety

Product Standards	IEC 60255-27:2013 IEEE C37.90-2005 21 CFR 1040.10
Dielectric Strength:	IEC 60255-27:2013, Section 10.6.4.3 2.5 kVac, 50/60 Hz for 1 min: analog inputs, contact outputs, digital inputs 3.6 kVdc for 1 min: power supply, battery monitors 2.2 kVdc for 1 min: IRIG-B 1.1 kVdc for 1 min: Ethernet

Impulse Withstand:	IEC 60255-27:2013, Section 10.6.4.2 IEEE C37.90-2005 Common Mode: ±1.0 kV: Ethernet ±2.5 kV: IRIG-B ±5.0 kV: all other ports Differential Mode: 0 kV: analog inputs, Ethernet, IRIG-B, digital inputs ±5.0 kV: standard contact outputs, power supply battery monitors +5.0 kV: hybrid contact outputs
Insulation Resistance:	IEC 60255-27:2013, Section 10.6.4.4 >100 MΩ @ 500 Vdc
Protective Bonding:	IEC 60255-27:2013, Section 10.6.4.5.2 <0.1 Ω @ 12 Vdc, 30 A for 1 min
Ingress Protection:	IEC 60529:2001 + CRGD:2003 IEC 60255-27:2013 IP30 for front and rear panel IP10 for rear terminals with installation of ring lug IP40 for front panel with installation of serial port cover
Max Temperature of Parts and Materials:	IEC 60255-27:2013, Section 7.3
Flammability of Insulating Materials:	IEC 60255-27:2013, Section 7.6 Compliant

Electromagnetic (EMC) Immunity

Product Standards:	IEC 60255-26:2013 IEC 60255-27:2013 IEEE C37.90-2005
Surge Withstand Capability (SWC):	IEC 61000-4-18:2006 + A:2010 IEEE C37.90.1-2012 Slow Damped Oscillatory, Common and Differential Mode: ±1.0 kV ±2.5 kV Fast Transient, Common and Differential Mode: ±4.0 kV
Electrostatic Discharge (ESD):	IEC 61000-4-2:2008 IEEE C37.90.3-2001 Contact: ±8 kV Air Discharge: ±15 kV
Radiated RF Immunity:	IEEE C37.90.2-2004 IEC 61000-4-3:2006 + A1:2007 + A2:2010 20 V/m (>35 V/m, 80% AM, 1 kHz) Sweep: 80 MHz to 1 GHz Spot: 80, 160, 450, 900 MHz 10 V/m (>15 V/m, 80% AM, 1 kHz) Sweep: 80 MHz to 1 GHz Sweep: 1.4 GHz to 2.7 GHz Spot: 80, 160, 380, 450, 900, 1850, 2150 MHz
Electrical Fast Transient Burst (EFTB):	IEC 61000-4-4:2012 Zone A: ±2 kV: communication ports ±4 kV: all other ports

Surge Immunity:	IEC 61000-4-5:2005 Zone A: ±2 kV _{L-L} ±4 kV _{L-E} ±4 kV: communication ports (Ethernet) Note: Cables connected to EIA-422, G.703, EIA-232, and IRIG-B communications ports shall be less than 10 m in length for Zone A compliance. Zone B: ±1 kV _{L-L} : 24–48 Vdc power supply ±2 kV _{L-E} : 24–48 Vdc power supply ±2 kV: communication ports (except Ethernet) Note: Cables connected to EIA-232 communications ports shall be less than 10 m in length for Zone B compliance.	Shock Resistance:	IEC 60255-21-2:1988 Class 1 Shock Withstand, Class 1 Bump Withstand, Class 2 Shock Response
		Seismic:	IEC 60255-21-3:1993 Class 2 Quake Response
Reporting Functions			
High-Resolution Data			
Rate:	8000 samples/second 4000 samples/second 2000 samples/second 1000 samples/second	Output Format:	Binary COMTRADE
	Note: Per IEEE C37.111-1999 and IEEE C37.111-2013, <i>IEEE Standard Common Format for Transient Data Exchange (COMTRADE) for Power Systems</i> .		
Event Reports			
Length:	0.25–24 seconds (based on LER and SRATE settings)	Volatile Memory:	3 s of back-to-back event reports sampled at 8 kHz
Nonvolatile Memory:	At least 4 event reports of a 3 s duration sampled at 8 kHz	Resolution:	8- or 4-samples/cycle
Event Summary			
Storage:	100 summaries		
HIF Event Reports			
Length:	2–20 minutes (based on the HIFLER setting)	Nonvolatile Memory:	At least two 20-minute reports or twenty 2-minute reports
Resolution:	1 sample per 2 power system cycles		
Breaker History			
Storage:	128 histories		
Sequential Events Recorder			
Storage:	1000 entries	Trigger Elements:	250 relay elements
Resolution:	0.5 ms for contact inputs	Resolution:	1/8 cycle for all elements
Processing Specifications			
AC Voltage and Current Inputs			
8000 samples per second, 3 dB low-pass analog filter cutoff frequency of 3000 Hz.			
Digital Filtering			
Full-cycle cosine and half-cycle Fourier filters after low-pass analog and digital filtering.			
Protection and Control Processing			
Eight times per power system cycle			
HIF Detection Processing			
Once every 50 cycles for FNOM = 50 Once every 60 cycles for FNOM = 60			
Control Points			
64 remote bits 64 local control bits 32 latch bits in protection logic 32 latch bits in automation logic			
Conducted Immunity:	IEC 61000-4-6:2013 20 V/m; (>35 V/m, 80% AM, 1 kHz) Sweep: 150 kHz–80 MHz Spot: 27, 68 MHz		
Power Frequency Immunity (DC Inputs):	IEC 61000-4-16:2015 Zone A: Differential: 150 V _{RMS} Common Mode: 300 V _{RMS}		
Power Frequency Magnetic Field:	IEC 61000-4-8:2009 Level 5: 100 A/m; ≥60 Seconds; 50/60 Hz 1000 A/m 1 to 3 Seconds; 50/60 Hz Note: 50G1P ≥0.05 (ESS = N, 1, 2) 50G1P ≥0.1 (ESS = 3, 4)		
Power Supply Immunity:	IEC 61000-4-11:2004 IEC 61000-4-17:1999/A1:2001/A2:2008 IEC 61000-4-29:2000 AC Dips & Interruptions Ripple on DC Power Input DC Dips & Interruptions Gradual Shutdown/Startup (DC only) Discharge of Capacitors Slow Ramp Down/Up Reverse Polarity (DC only)		
Damped Oscillatory Magnetic Field:	IEC 61000-4-10:2016 Level 5: 100 A/m		
EMC Compatibility			
Product Standards:	IEC 60255-26:2013		
Emissions:	IEC 60255-26:2013, Section 7.1, Class A 47 CFR Part 15B, Class A Canada ICES-001 (A) / NMB-001 (A)		
Environmental			
Product Standards:	IEC 60255-27:2013		
Cold, Operational:	IEC 60068-2-1:2007 Test Ad: 16 hours at –40°C		
Cold, Storage:	IEC 60068-2-1:2007 Test Ad: 16 hours at –40°C		
Dry Heat, Operational:	IEC 60068-2-2:2007 Test Bd: 16 hours at +85°C		
Dry Heat, Storage:	IEC 60068-2-2:2007 Test Bd: 16 hours at +85°C		
Damp Heat, Cyclic:	IEC 60068-2-30:2005 Test Db: +25°C to +55°C, 6 cycles (12 + 12-hour cycle), 95% RH		
Damp Heat, Steady State:	IEC 60068-2-78:2013 Severity: 93% RH, +40°C, 10 days		
Cyclic Temperature:	IEC 60068-2-14:2009 Test Nb: –40°C to +80°C, 5 cycles		
Vibration Resistance:	IEC 60255-21-1:1988 Class 2 Endurance, Class 2 Response		

Relay Element Pickup Ranges and Accuracies

Instantaneous/Definite-Time Overcurrent Elements

Phase, Residual Ground, and Negative-Sequence

Pickup Range

5 A Model:	OFF, 0.25–100.00 A secondary, 0.01 A steps
1 A Model:	OFF, 0.05–20.00 A secondary, 0.01 A steps

Accuracy (Steady State)

5 A Model:	± 0.05 A plus $\pm 3\%$ of setting
1 A Model:	± 0.01 A plus $\pm 3\%$ of setting

Transient Overreach: < 5% of pickup

Time Delay: 0.000–16000 cycles, 0.125 cycle steps

Timer Accuracy: ± 0.125 cycle plus $\pm 0.1\%$ of setting

Maximum Operating Time: 1.5 cycles

Time-Overcurrent Elements

Pickup Range

5 A Model:	0.25–16.00 A secondary, 0.01 A steps
1 A Model:	0.05–3.20 A secondary, 0.01 A steps

Accuracy (Steady State)

5 A Model:	± 0.05 A plus $\pm 3\%$ of setting
1 A Model:	± 0.01 A plus $\pm 3\%$ of setting

Time-Dial Range

U.S.:	0.50–15.00, 0.01 steps
IEC:	0.05–1.00, 0.01 steps

Curve Timing Accuracy: ± 1.50 cycles plus $\pm 4\%$ of curve time (for current between 2 and 30 multiples of pickup)

Reset: 1 power cycle or Electromechanical Reset Emulation time

Harmonic Elements (2nd, 4th, 5th)

Pickup Range: OFF, 5–100% of fundamental

Pickup Accuracy: 1 A nominal $\pm 5\% \pm 0.02$ A
5 A nominal $\pm 5\% \pm 0.10$ A

Time-Delay Accuracy: $\pm 0.1\%$ plus ± 0.125 cycle

Ground Directional Elements

Neg.-Seq. Directional Impedance Threshold (Z2F, Z2R)

5 A Model:	–64 to 64 Ω secondary
1 A Model:	–320 to 320 Ω secondary

Zero-Seq. Directional Impedance Threshold (Z0F, Z0R)

5 A Model:	–64 to 64 Ω secondary
1 A Model:	–320 to 320 Ω secondary

Supervisory Overcurrent Pickup (50FP, 50RP)

5 A Model:	0.25 to 5.00 A 3I0 secondary 0.25 to 5.00 A 3I2 secondary
1 A Model:	0.05 to 1.00 A 3I0 secondary 0.05 to 1.00 A 3I2 secondary

Directional Power Elements

Pickup Range

5 A Model:	–20000.00 to 20000 VA, 0.01 VA steps
1 A Model:	–4000.00 to 4000 VA, 0.01 VA steps

Accuracy (Steady State): ± 5 VA plus $\pm 3\%$ of setting at nominal frequency and voltage

Time-Delay: 0.00–16000.00 cycles, 0.25 cycle steps

Timer Accuracy: ± 0.25 cycle plus $\pm 0.1\%$ of setting

Undervoltage and Overvoltage Elements

Pickup Ranges

300 V Maximum Inputs

Phase Elements:	2–300 V secondary, 0.01 V steps
Phase-to-Phase Elements:	4–520 V secondary, 0.01 V steps

8 V LEA Maximum Inputs

(See *Voltage-Related Settings and LEA Inputs (Group Settings)* in the *SEL-451 Instruction Manual* for information on setting voltage elements when using LEA inputs.)

Phase:	0.05–8.00 V
Phase-to-Phase:	0.10–13.87 V

Accuracy (Steady State)

Phase Elements:	± 0.5 V plus $\pm 3\%$ of setting
Sequence Elements:	± 0.5 V plus $\pm 5\%$ of setting

Transient Overreach: < 5% of pickup

Underfrequency and Overfrequency Elements

Pickup Range: 40.01–69.99 Hz, 0.01 Hz steps

Accuracy, Steady State plus Transient: ± 0.005 Hz for frequencies between 40.00 and 70.00 Hz

Maximum Pickup/Dropout

Time: 3.0 cycles

Time-Delay Range: 0.04–400.0 s, 0.01 s increments

Time-Delay Accuracy: $\pm 0.1\% \pm 0.0042$ s

Pickup Range,

Undervoltage Blocking: 20–200 V_{LN} (Wye)

Pickup Accuracy,

Undervoltage Blocking: $\pm 2\% \pm 0.5$ V

Optional RTD Elements

(Models Compatible With SEL-2600 Series RTD Module)

12 RTD Inputs via SEL-2600 Series RTD Module and SEL-2800 Fiber-Optic Transceiver

Monitor Ambient or Other Temperatures

PT 100, NI 100, NI 120, and CU 10 RTD-Types Supported, Field Selectable

Pickup Range: Off, –50 to 250°C, 1°C step

Accuracy: $\pm 2^\circ$ C

As long as 500 m Fiber-Optic Cable to SEL-2600 Series RTD Module

Breaker Failure Instantaneous Overcurrent

Setting Range

5 A Model:	0.50–50.0 A, 0.01 A steps
1 A Model:	0.10–10.0 A, 0.01 A steps

Accuracy

5 A Model:	± 0.05 A plus $\pm 3\%$ of setting
1 A Model:	± 0.01 A plus $\pm 3\%$ of setting

Transient Overreach: < 5% of setting

Maximum Pickup Time: 1.5 cycles

Maximum Reset Time: 1 cycle

Timers Setting Range: 0–6000 cycles, 0.125 cycle steps
(All but BFIDOn, BFISPr)
0–1000 cycles, 0.125 cycle steps
(BFIDOn, BFISPr)

Time-Delay Accuracy: 0.125 cycle plus $\pm 0.1\%$ of setting

Synchronism-Check Elements

Slip Frequency

Pickup Range: 0.005–0.500 Hz, 0.001 Hz steps

Slip Frequency

Pickup Accuracy: ± 0.0025 Hz plus $\pm 2\%$ of setting

Close Angle Range: 3–80°, 1° steps

Close Angle Accuracy: $\pm 3^\circ$ plus $\pm 5\%$ of setting

Load-Encroachment Detection

Setting Range

5 A Model:	0.05–64 Ω secondary, 0.01 Ω steps
1 A Model:	0.25–320 Ω secondary, 0.01 Ω steps
Forward Load Angle:	–90° to +90°
Reverse Load Angle:	+90° to +270°

Accuracy

Impedance Measurement:	±3%
Angle Measurement:	±2°

High-Impedance Fault Detection

Minimum Current

5 A Model:	0.25 A
1 A Model:	0.05 A

Accuracy

5 A Model:	0.25 A ±2.5 mA
1 A Model:	0.05 A ±0.5 mA

Timer Specifications

Setting Ranges

Breaker Failure:	0–6000 cycles, 0.125 cycle steps (All but BFIDOn, BFISPr)
	0–1000 cycles, 0.125 cycle steps (BFIDOn, BFISPr)
Communications-Assisted Tripping Schemes:	0.000–16000 cycles, 0.125 cycle steps
Pole Open Timer:	0.000–60 cycles, 0.125 cycle steps
Recloser:	1–999999 cycles, 1 cycle steps

Switch-Onto-Fault

CLOEND, 52AEND:	OFF, 0.000–16000 cycles, 0.125 cycle steps
SOTFD:	0.500–16000 cycles, 0.125 cycle steps

Synchronism-Check Timers

TCLSBK1, TCLSBK2:	1.00–30.00 cycles, 0.25 cycle steps
-------------------	-------------------------------------

Station DC Battery System Monitor Specifications

Rated Voltage:	24–250 Vdc
Operational Voltage Range:	0–300 Vdc
Sampling Rate:	DC1: 2 kHz DC2: 1 kHz
Processing Rate:	1/8 cycle
Operating Time:	<1.5 cycles (all elements except ac ripple) <1.5 seconds (ac ripple element)
Setting Range	
DC Settings:	1 Vdc steps (OFF, 15–300 Vdc)
AC Ripple Setting:	1 Vac steps (1–300 Vac)
Pickup Accuracy:	±3% ±2 Vdc (all elements except ac ripple) ±10% ±2 Vac (ac ripple element)

Metering Accuracy

All metering accuracy is at 20°C, and nominal frequency unless otherwise noted.

Currents

Phase Current Magnitude

5 A Model:	±0.2% plus ±4 mA (2.5–15 A sec)
1 A Model:	±0.2% plus ±0.8 mA (0.5–3 A sec)

Phase Current Angle

All Models:	±0.2° in the current range 0.5 • I _{NOM} to 3.0 • I _{NOM}
-------------	--

Sequence Currents Magnitude

5 A Model:	±0.3% plus ±4 mA (2.5–15 A sec)
1 A Model:	±0.3% plus ±0.8 mA (0.5–3 A sec)

Sequence Current Angle

All Models:	±0.3° in the current range 0.5 • I _{NOM} to 3.0 • I _{NOM}
-------------	--

Voltages

300 V Maximum Inputs

Phase and Phase-to-Phase Voltage Magnitude:	±2.5% ±1 V (5–33.5 V) ±0.1% (33.5–300 V)
--	---

Phase and Phase-to-Phase Angle:	±1.0° (5–33.5 V) ±0.5° (33.5–300 V)
------------------------------------	--

Sequence Voltage Magnitude (V1, V2, 3V0):	±2.5%, ±1 V (5–33.5 V) ±0.1% (33.5–300 V)
--	--

Sequence Voltage Angle (V1, V2, 3V0):	±1.0° (5–33.5 V) ±0.5° (33.5–300 V)
--	--

8 V LEA Maximum Inputs

Phase and Phase-to-Phase Voltage Magnitude:	±0.3% (0.2–0.6 V) ±0.1% (0.6–8.0 V)
--	--

Phase and Phase-to-Phase Angle:	±0.5° (0.2–8.0 V)
------------------------------------	-------------------

Sequence Voltage Magnitude (V1, V2, 3V0):	±0.3% (0.2–0.6 V) ±0.1% (0.6–8.0 V)
--	--

Sequence Voltage Angle (V1, V2, 3V0):	±0.5° (0.2–8.0 V)
--	-------------------

Frequency (Input 40–65 Hz)

Accuracy:	±0.01 Hz
-----------	----------

Power

MW (P), Per Phase (Wye), 3φ (Wye or Delta) Per Terminal

±1% (0.1–1.2) • I _{NOM} , 33.5–300 Vac, PF = 1, 0.5 lead, lag (1φ)
±0.7% (0.1–1.2) • I _{NOM} , 33.5–300 Vac, PF = 1, 0.5 lead, lag (3φ)

MVar (Q), Per Phase (Wye), 3φ (Wye or Delta) Per Terminal

±1% (0.1–1.2) • I _{NOM} , 33.5–300 Vac, PF = 0, 0.5 lead, lag (1φ)
±0.7% (0.1–1.2) • I _{NOM} , 33.5–300 Vac, PF = 0, 0.5 lead, lag (3φ)

MVA (S), Per Phase (Wye), 3φ (Wye or Delta) Per Terminal

±1% (0.1–1.2) • I _{NOM} , 33.5–300 Vac, PF = 1, 0.5 lead, lag (1φ)
±0.7% (0.1–1.2) • I _{NOM} , 33.5–300 Vac, PF = 1, 0.5 lead, lag (3φ)

PF, Per Phase (Wye), 3φ (Wye or Delta) Per Terminal

±1% (0.1–1.2) • I _{NOM} , 33.5–300 Vac, PF = 1, 0.5 lead, lag (1φ)
±0.7% (0.1–1.2) • I _{NOM} , 33.5–300 Vac, PF = 1, 0.5 lead, lag (3φ)

Energy

MWh (P), Per Phase (Wye), 3φ (Wye or Delta)

±1% (0.1–1.2) • I _{NOM} , 33.5–300 Vac, PF = 1, 0.5 lead, lag (1φ)
±0.7% (0.1–1.2) • I _{NOM} , 33.5–300 Vac, PF = 1, 0.5 lead, lag (3φ)

Synchrophasors

Number of Synchrophasor Data Streams:	5
--	---

Number of Synchrophasors for Each Stream:

15 Phase Synchrophasors (6 Voltage and 9 Currents)
5 Positive-Sequence Synchrophasors (2 Voltage and 3 currents)

Number of User Analogs for Each Stream:	16 (any analog quantity)
--	--------------------------

Number of User Digitals for Each Stream:	64 (any Relay Word bit)
---	-------------------------

Synchrophasor Protocol:	IEEE C37.118-2005, SEL Fast Message (Legacy)
-------------------------	---

Synchrophasor Data Rate:	As many as 60 messages per second
--------------------------	-----------------------------------

Synchrophasor Accuracy

Voltage Accuracy:	±1% Total Vector Error (TVE) Range 30–150 V, f _{NOM} ±5 Hz
-------------------	--

Current Accuracy:	$\pm 1\%$ Total Vector Error (TVE) Range $(0.1-2.0) \cdot I_{NOM} A, f_{NOM} \pm 5$ Hz
Synchrophasor Data Recording:	Records as much as 120 s IEEE C37.232-2011, File Naming Convention

Technical Support

We appreciate your interest in SEL products and services. If you have questions or comments, please contact us at:

Schweitzer Engineering Laboratories, Inc.
2350 NE Hopkins Court
Pullman, WA 99163-5603 U.S.A.
Tel: +1.509.338.3838
Fax: +1.509.332.7990
Internet: selinc.com/support
Email: info@selinc.com

Notes

© 2010-2024 by Schweitzer Engineering Laboratories, Inc.

Content subject to change without notice.

Unless otherwise agreed in writing, all SEL product sales are subject to SEL's terms and conditions located here: <https://selinc.com/company/termsandconditions/>.

EtherCAT® is registered trademark and patented technology, licensed by Beckhoff Automation GmbH, Germany.

SCHWEITZER ENGINEERING LABORATORIES, INC.

2350 NE Hopkins Court • Pullman, WA 99163-5603 U.S.A.

Tel: +1.509.332.1890 • Fax: +1.509.332.7990

selinc.com • info@selinc.com



* P D S 4 5 1 - 0 3 *