

Cod. Code <b>7000619</b>	Peso totale Total weight <b>91 Kg</b>	Materiale Construction <b>GHISA EN-GJL-250 CAST IRON EN-GJL-250</b>	Girante Impeller <b>CUTTING EDGES</b>
--------------------------	---------------------------------------	---	---------------------------------------

Idraulica - Hydraulic	
MANDATA DISCHARGE	<b>DN 100 mm</b>
ASPIRAZIONE SUCTION	<b>DN 100 mm</b>
PASSAGGIO LIBERO FREE PASSAGE	<b>50 mm</b>
DIAMETRO GIRANTE IMPELLER DIAMETER	<b>190 mm</b>

Motore- Motor		M410T-3,9-400/50YY-IE3		
ALIMENTAZIONE POWER SUPPLY	<b>3ph 400/690V-50Hz</b>			
CLASSE DI ISOLAMENTO INSULATION CLASS	<b>H</b>			
VELOCITÀ NOMINALE NOMINAL SPEED	<b>1401 rpm</b>			
POTENZA NOMINALE MOTORE RATED MOTOR POWER	<b>3,9 kW</b>			
CORRENTE DI SPUNTO STARTING CURRENT	<b>39,5 A</b>			
CORRENTE NOMINALE RATED CURRENT	<b>7,9 A</b>			
MOMENTO DI INERZIA TOTALE TOTAL MOMENT OF INERTIA	<b>0,0210 kgm2</b>			
	CARICO-LOADING			
	4/4	3/4	1/2	
FATTORE DI POTENZA POWER FACTOR	<b>0,80</b>	<b>0,74</b>	<b>0,65</b>	
RENDIMENTO MOTORE MOTOR EFFICIENCY	<b>90 %</b>	<b>89 %</b>	<b>87 %</b>	

Impiego - Application	
TEMP. MAX DEL LIQUID PUMPED LIQUID MAX TEMP.	<b>&lt; 40 °C</b>
PROTEZIONE MECCANICA MECHANICAL PROT. DEGREE	<b>IP 68</b>
CAVO CABLE	<b>12G1,5 H07RNF</b>
CODICE DISEGNO DRAWING CODE	<b>710_100_10_9</b>
CURVA CURVE	<b>C710-411</b>

Rend. max - Best efficiency	
RENDIMENTO TOTALE TOTAL EFFICIENCY	<b>56,1 %</b>
RENDIMENTO IDRAULICO HYDRAULIC EFFICIENCY	<b>62,6 %</b>
POT. ASS. DALLA RETE ABS. POWER FROM MAINS	<b>3,1 kW</b>
PREVALENZA HEAD	<b>7,1 m</b>
PORTATA CAPACITY	<b>88,5 m³/h</b>

Protezioni - Protections	
PROTEZIONE TERMICA THERMAL PROTECTION	<input checked="" type="checkbox"/> YES
CONTROLLO INFILTRAZIONE HUMIDITY PROBE	<input checked="" type="checkbox"/> YES
II 2G Ex c k db IIB T4 Gb	<input type="checkbox"/> NO
MANTELLINO DI RAFFREDDAMENTO COOLING JACKET	<input type="checkbox"/> NO

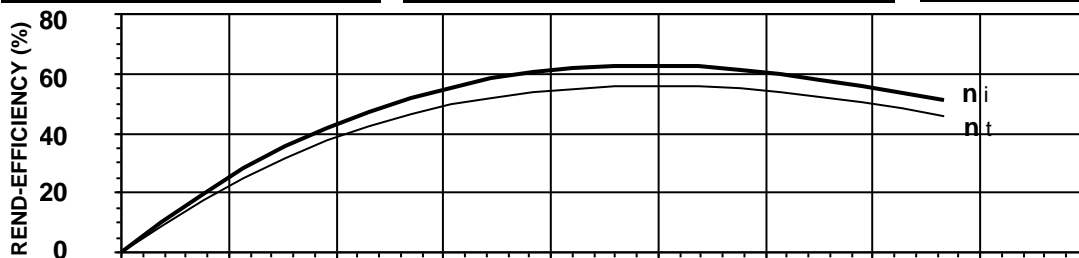

$\eta_i$  = Rendimento idraulico  
Hydraulic efficiency

$\eta_t$  = Rendimento totale  
Total efficiency

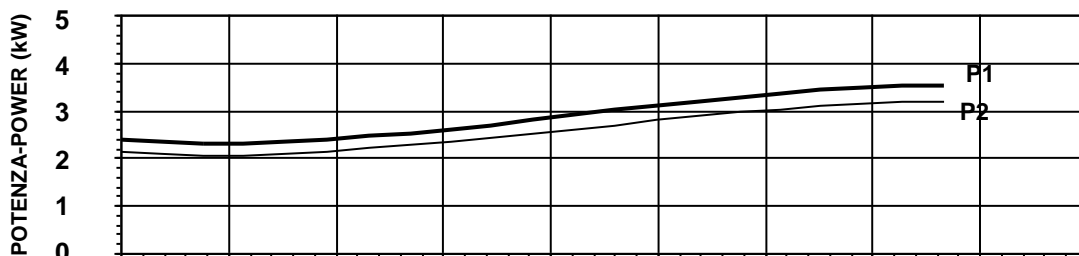

**P1** = Potenza ass. dalla rete  
Abs. power from mains

**P2** = Potenza idraulica  
Hydraulic power

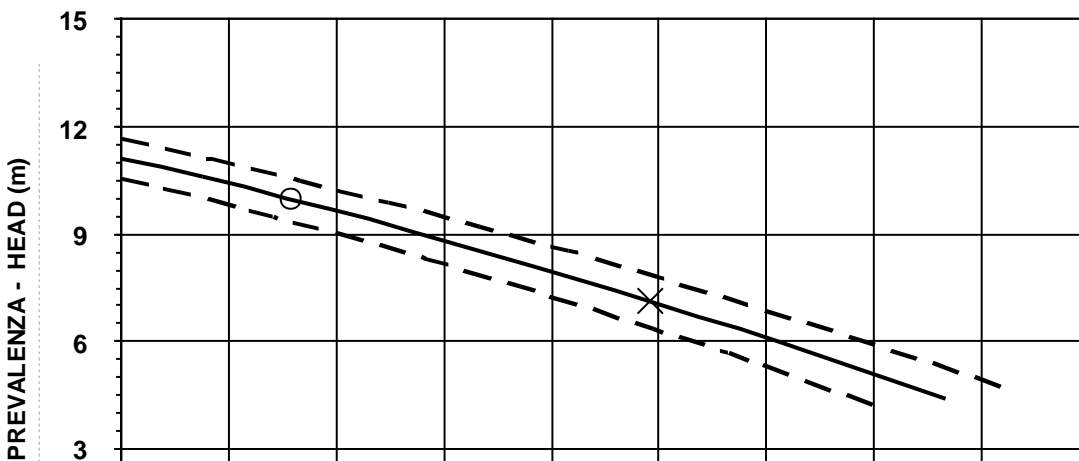

**O** = Portata minima  
Minimum capacity

**X** = Punto max rendimento  
Best efficiency point



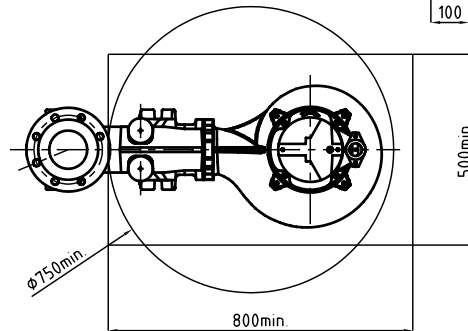
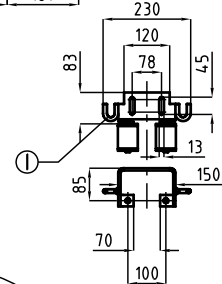
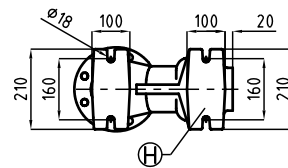
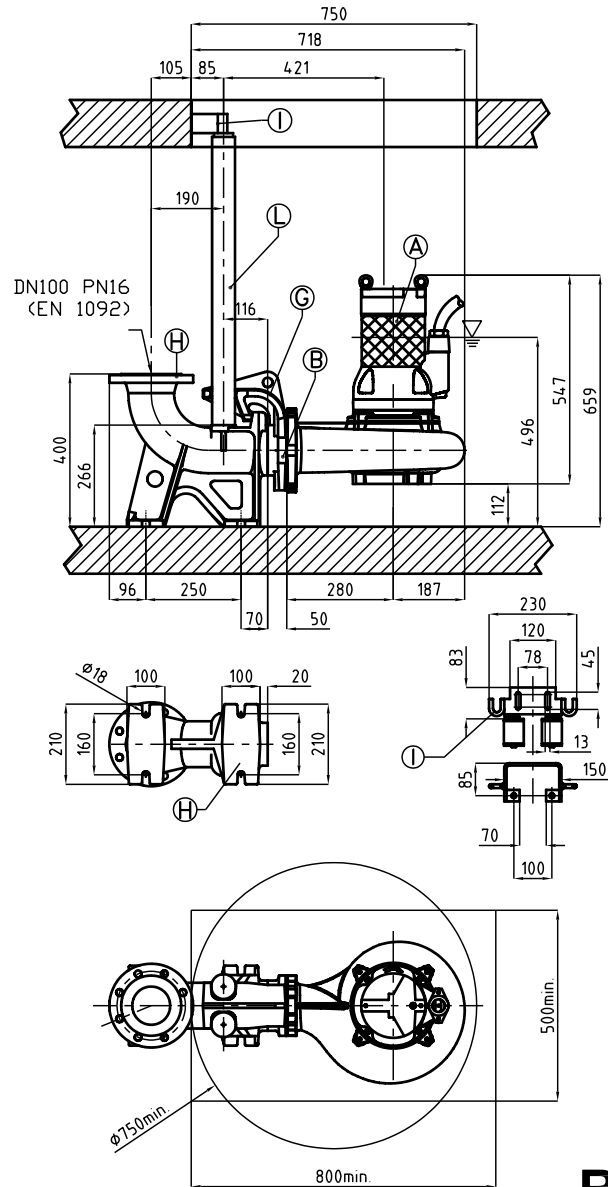
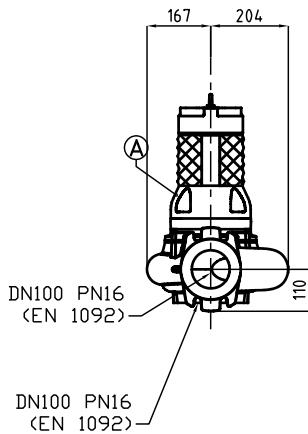
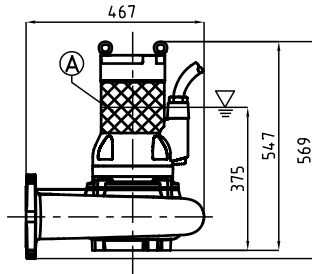
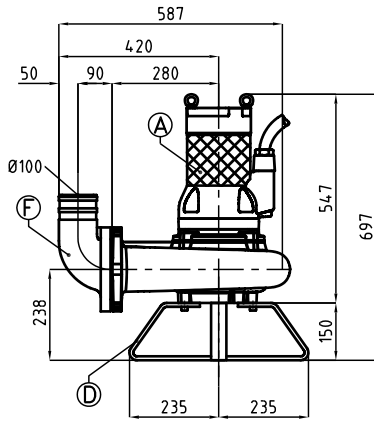

**R**

Pos.	Codice	Descrizione	Materiale	Peso Kg
Pos.	Code	Description	Material	Weight Kg
<b>A</b>	-	Elettropompa Sommersibile Submersible Pump	-	-
<b>B</b>	54.11015	Guarnizione DN100 Rubber joint DN100	Neoprene Neoprene	0,06
<b>Type: P</b>				
<b>D</b>	PAPDN100NP0 7	Tripiede appoggio X foot rest	Acciaio zincato Galvanized Steel	5
<b>F</b>	GCDN100/L	Curva di mandata 90° DN100 Delivery elbow 90° DN100	G250 Ghisa G250 Cast-Iron	10
<b>Type: R</b>				
<b>GPADN100/L</b>				
<b>G</b>	GADT100-150	Controflangia accoppiamento 2 guide DN100 Double guide rail coupling flange DN100	G250 Ghisa G250 Cast-Iron	12
<b>H</b>	GBPACDN100	Piede d'accoppiamento 2 guide DN100 Double guide coupling feet DN100	G250 Ghisa G250 Cast-Iron	35
<b>I</b>	SOP2T	Sopporto tubi superiore 2 guide 2" Double guide rail upper support 2"	Acciaio zincato Galvanized Steel	1,9
<b>L</b>	TG2Z	Tubo guida 2" Guide rail 2"	Acciaio zincato Galvanized Steel	4,5

▽ LIVELLO MINIMO DI SOMMERGIBILITÀ STANDARD.  
PER VERSIONE ATEX, COMPLETAMENTE SOMMERSA.

▽ MINIMUM SUBMERSIBLE LEVEL STANDARD.  
FOR ATEX TYPE, COMPLETELY SUBMERGED.

**P**