

TECHNICAL CONSTRUCTION FILE

File No.:
TCF_HE-LD23081804

Project:
FLOOR SAW
Model: GFS120, GFS380, GFS480, GFS450, GFS220, GFS600, GFS520, GFS580,
GFS750, GFS800, GFS1000

Holder:
LUDWIG MACHINERY EQUIPMENT MANUFACTURING CO., LTD.
NO.88 JIUDINGSHAN ROAD, XINZHAN INDUSTRIAL DISTRICT,
HEFEI CITY, ANHUI PROVINCE, P. R. CHINA

Manufacturer:
LUDWIG MACHINERY EQUIPMENT MANUFACTURING CO., LTD.
NO.88 JIUDINGSHAN ROAD, XINZHAN INDUSTRIAL DISTRICT,
HEFEI CITY, ANHUI PROVINCE, P. R. CHINA



Edition 1.0, Rev. 0, 2023.08

The document was prepared using best effort. The authors make no warranty of any kind and shall not be liable in any event for incidental or consequential damages in connection with the application of the document.

First emission date:

23/08/2023

Date of inspection:

24/08/2023

Prepared by:

Ing. Simon Jiang

Signature of Ing.



Holder:

LUDWIG MACHINERY EQUIPMENT MANUFACTURING CO., LTD.
NO.88 JIUDINGSHAN ROAD, XINZHAN INDUSTRIAL DISTRICT,
HEFEI CITY, ANHUI PROVINCE, P. R. CHINA

Manufacturer:

LUDWIG MACHINERY EQUIPMENT MANUFACTURING CO., LTD.
NO.88 JIUDINGSHAN ROAD, XINZHAN INDUSTRIAL DISTRICT,
HEFEI CITY, ANHUI PROVINCE, P. R. CHINA

Summary:

Conformity assessment for the Directive 2006/42/EC defined

was performed on the equipment described as

FLOOR SAW

Model: GFS120, GFS380, GFS480, GFS450, GFS220, GFS600, GFS520, GFS580, GFS750, GFS800,
GFS1000

The outcome of the evaluation was positive.

Catalog

1. Report Summary	4
2. Product Description	5
3. Procedure of conformity assessment	6
4. Mark of conformity 'CE'	7
5. Conclusions	8
Annex 01: Assessment report EHSR.....	9
Annex 02: Risk Assessment report (EN 12100)	46
Annex 03: Assessment report (EN 13862)	56
Technical document list	69

1. Report Summary

The manufacturer has performed an evaluation of the conformity to the directive 2006/42/EC the following machine:

FLOOR SAW

Model: GFS120, GFS380, GFS480, GFS450, GFS220, GFS600, GFS520, GFS580, GFS750, GFS800, GFS1000

Including the technical documentation supplied, manufactured by:

LUDWIG MACHINERY EQUIPMENT MANUFACTURING CO., LTD.
NO.88 JIUDINGSHAN ROAD, XINZHAN INDUSTRIAL DISTRICT,
HEFEI CITY, ANHUI PROVINCE, P. R. CHINA

The assessment was performed upon the request of the manufacturer with intervention request dated 23/08/2023, copied in annex to this report.

The evaluation was performed by Ing. Simon Jiang.

The machine installed at the plant and including the technical documentation which prepared by the manufacturer.

2. Product Description

OPERATING PRINCIPLE

The following instructions were compiled to provide you information on how to obtain long and trouble free use of the unit. Periodic maintenance of this unit is essential. Read the manual in its entirety and follow the instructions carefully. Failure to do so may injure yourself or a bystander.

Model	GFS120	GFS380	GFS480	GFS450	GFS220	GFS600
Engine Type	Honda GX160	Honda GX390	Honda GX390	Honda GX390	Honda GX390	Honda GX390
Power kw(hp)	4.0(5.5)	9.6(13.0)	9.6(13.0)	9.6(13.0)	9.6(13.0)	9.6(13.0)
Operation Mass kg(lbs)	83 (186)	144 (323)	195(437)	108(237)	105(229)	110(220)
Max.Cutting Depth cm(in)	9 (3.5)	14 (5.5)	17(6.7)	17(6.7)	17(6.7)	18.5(7.3)
Blade Size cm(in)	30-35(12-14)	30-40(12-16)	35-50(14-20)	35-45(14-18)	35-45(14-18)	35-50(14-20)
Depth Adjustment	Handle Rotation	Handle Rotation	Handle Rotation	Handle Rotation	Handle Rotation	Handle Rotation
Driving	Manual Push	Manual Push	Manual Push	Manual Push	Manual Push	Semi-self Propelled
Water tank Capacity L	12	35	40	30	27	35
Dimension cm(in)	165x48x95(65x19x37)	155x60x95(61x24x38)	180x55x105(70x21x41)	110x60x98(44x24x39)	130x63x99(51x25x40)	116x56x98(46x22x39)

Model	GFS520	GFS580	GFS750	GFS800	GFS1000	
Engine Type	Honda GX390	Honda GX390	Honda GX390	Honda GX390	Honda GX390	
Power kw(hp)	9.6(13.0)	9.6(13.0)	9.6(13.0)	9.6(13.0)	9.6(13.0)	
Operation Mass kg(lbs)	164 (362)	140 (309)	106(112)	145(320)	110(220)	
Max.Cutting Depth cm(in)	26 (10)	20 (7.8)	14 (5.5)	15(6.0)	18.5(7.3)	
Blade Size cm(in)	35-60(14-24)	35-50(14-20)	30-40(12-16)	45(18)	35-50(14-20)	
Depth Adjustment	Handle Rotation	Handle Rotation	Handle Rotation	Handle Rotation	Handle Rotation	
Driving	Manual Push	Manual Push	Manual Push	Manual Push	Semi-self Propelled	
Water tank Capacity L	46	46	35	46	35	
Dimension cm(in)	130x63x99(51x25x40)	130x63x99(51x25x40)	155x60x95(61x24x38)	125x73x86(49x29x34)	116x56x98(46x22x39)	



3. Procedure of conformity assessment

The products come within the definition of machine given by

- Directive 2006/42/EC and excluded Annex IV of the Directive.

The products applying the CE marking for the first time.

3.1. Technical file

The manufacturer delivered to the certification body Swiss Approval (hereinafter SAI) the technical file of the machines. After careful examination, SAI has found in this technical file all the documents listed in Annex VII of the Directive 2006/42/EC.

The outcome of the technical documentation is provided and attached to this report.

3.2. Consideration of type

The examination of the machine type was conducted, on the copy only identified with the models: GFS120; photographic documentation on the examination type is kept in the archives of SAI.

3.3. Compliance of the documentation to the machine

As part of the kind it has occurred that the documentation contained in the technical dossier examined corresponded to the machine.

After visual examination has found that the documents submitted correspond to the machine being tested, in particular as regards:

- The safety systems;
- The warning signs.

It was verified that the user manual and maintenance corresponded to the machine is subject to the type.

Finally, we examined the contents of the user manual and maintenance checking their correspondence to the machine specifically with regard to:

- The size and the operability of the safety components;
- The procedures for starting and stopping;
- The procedures for emergency stop and subsequent restoration;
- The control system / control;
- The controls for the operator.

The contents of the technical file are consistent with the requirements of the Directive and the corresponding machine is subject to the type.

3.4. Compliance of the machine to the EHSR

In this phase it has been verified through the features of the machine:

- The examination of the technical documentation (technical file);
- Visual examination;
- The simulation of abnormal operating conditions, reasonably foreseeable.

With stationary and not fed occurred:

- The accessibility of the machine by the user and maintainer of the positions described in the manual of use and maintenance;
- The positioning of the control devices and signaling, with particular regard for the actuators of the stop function of emergency;
- the arrangement of the safety devices;

Subsequently, in operating conditions, tests were carried out regarding the operation of the controls and safety devices:

- Control and stop installed on the electrical panel and pushbutton for local control;
- Acoustic devices;
- Emergency stop devices.

Finally, in operating conditions, tests were carried out regarding the electromagnetic disturbance and immunity to the electromagnetic disturbance.

The compliance of the essential safety requirements of Annex I to Directive 2006/42/EC is set out in the Check assessment report for EHSR, attached to this report and an integral part thereof.

The machine was also subject, as appropriate, the technical standards mentioned in the technical dossier of the manufacturer: testing was performed using the following Check Doc assessment report for EHSR, a copy of which is preserved in the archives of SAI.

4. Mark of conformity 'CE'

The considerations in this document are related only to the machine being tested and the documentation assessed regarding the aspects of the Directive 2006/42/EC.

In order to affix the label must be properly satisfied all ESHR of other applicable EU directives/regulations if possible. The proper implementation of these requirements is not part of this evaluation.

5. Conclusions

SAI has verified that:

- a. the manufacturer arranged technical documentation according the Directive(s);
- b. the manufacturer carried out relevant tests, measures, checks and verification on the devices in object, in order to verify their compliance with the documentation referred in the previous paragraphs, and the correct execution in respect with the project compliant to the standards;

and considers the equipment:

TYPE OF EQUIPMENT

FLOOR SAW

Model: GFS120, GFS380, GFS480, GFS450, GFS220, GFS600, GFS520, GFS580,
GFS750, GFS800, GFS1000

manufactured by LUDWIG MACHINERY EQUIPMENT MANUFACTURING CO., LTD., with manufacturing plant in Add: NO.88 JIUDINGSHAN ROAD, XINZHAN INDUSTRIAL DISTRICT, HEFEI CITY, ANHUI PROVINCE, P. R. CHINA

TO BE DECLARED CONFORM

in accordance with the requirements of harmonized standards:

- EN ISO 12100:2010
- EN 13862:2021

and essential health and safety requirements of Directive 2006/42/EC.

Here the list of the annexes, which are integral part of this report:

- Annex 01: Assessment report EHSR
- Annex 02: Risk Assessment report (EN 12100)
- Annex 03: Assessment report (EN 13862)

Annex 01: Assessment report EHSR

Notes of this part

It has been agreed that compliance with the Machinery Directive 2006/42/EC, Annex I, Essential health and safety requirements relating to the design and construction of machinery.

This part of 2006/42/EC provides requirements and recommendations relating to the Essential health and safety requirements relating to the design and construction of machinery so as to promote:

- safety of persons and property;
- consistency of control response;
- ease of maintenance.

Clause	Comment	Pass? Y/N/NA
1. <i>ESSENTIAL HEALTH AND SAFETY REQUIREMENTS</i> 1.1. GENERAL REMARKS 1.1.1. Definitions For the purpose of this Annex: (a) 'hazard' means a potential source of injury or damage to health; (b) 'danger zone' means any zone within and/or around machinery in which a person is subject to a risk to his health or safety; (c) 'exposed person' means any person wholly or partially in a danger zone; (d) 'operator' means the person or persons installing, operating, adjusting, maintaining, cleaning, repairing or moving machinery; (e) 'risk' means a combination of the probability and the degree of an injury or damage to health that can arise in a hazardous situation; (f) 'guard' means a part of the machinery used specifically to provide protection by means of a physical barrier; (g) 'protective device' means a device (other than a guard) which reduces the risk, either alone or in conjunction with a guard; (h) 'intended use' means the use of machinery in accordance with the information provided in the instructions for use; (i) 'reasonably foreseeable misuse' means the use of machinery in a way not intended in the instructions for use, but which may result from readily predictable human behavior.		
1.1.2. Principles of safety integration		
(a) Machinery must be designed and constructed so that it can be operated without putting persons at risk when operated normally throughout the foreseeable lifetime of the machinery including the phases of transport, assembly, dismantling, disabling and scrapping.	All of these have been taken into consideration during design.	Y
Machinery must be designed and constructed so that it can be operated without putting persons at risk during foreseeable misuse throughout the foreseeable lifetime of the machinery including the phases of transport, assembly, dismantling, disabling and scrapping.	It cannot cause any hazards in the situation.	Y
Machinery must be designed and constructed so that it can be adjusted and maintained without putting persons at risk when these operations are carried out under the conditions foreseen during the lifetime of the machinery including the phases of transport, assembly, dismantling, disabling and scrapping	No hazard will happen at this situation,	Y
Machinery must be designed and constructed so that it can be adjusted and maintained without putting persons at risk when these operations are carried out during any reasonably foreseeable misuse including the phases of transport, assembly, dismantling, disabling and scrapping	The maintenance points are without hazard.	Y

(b) The manufacturer must eliminate or reduce risks as far as possible using inherently safe machinery design and construction	Please see the manual.	Y
Where risks cannot be eliminated, the manufacturer must take the necessary protective measures	Safety guards are used.	Y
Users must be informed of residual risks, indicating training needs or the need for personal protective equipment	Warning labels are affixed.	Y
(c) The machinery must be designed and constructed in such a way as to prevent abnormal use if such use would engender a risk.		Y
Where appropriate, the instructions must draw the user's attention to ways — which experience has shown might occur — in which the machinery should not be used.	Please see the manual	Y
(d) Machinery must be designed and constructed to take account of the constraints to which the operator is subject as a result of the necessary or foreseeable use of personal protective equipment.		Y
(e) Machinery must be supplied with all the special equipment and accessories essential to enable it to be adjusted, maintained and used safely.	Please see the manual	Y
1.1.3. Materials and products		
The materials used to construct machinery or products used or created during its use must not endanger persons' safety or health. In particular, where fluids are used, machinery must be designed and constructed to prevent risks due to filling, use, recovery or draining.	The used material can't cause any danger to persons.	Y
1.1.4. Lighting		
Machinery must be supplied with integral lighting suitable for the operations concerned where an absence of light is likely to cause a risk despite ambient lighting of normal intensity.		NA
Machinery must be designed and constructed so that there is no area of shadow likely to cause nuisance		NA
Machinery must be designed and constructed so that there is no irritating dazzle		NA
Internal parts requiring frequent inspection and adjustment, and maintenance areas must be provided with appropriate lighting.		NA
1.1.5. Design of machinery to facilitate its handling		
Machinery, or each component must be capable of being handled and transported safely		Y
Machinery or each component must be packaged or designed so that it can be stored safely and without damage.	No damage happens	Y
During the transportation of the machinery and/or its component parts, there must be no possibility of sudden movements or of hazards due to instability as long as the machinery and/or its component parts are handled in accordance with the instructions.	No this hazard will happen	Y
Where the weight, size or shape of machinery or its various component parts prevents them from being moved by hand, the machinery or each component part must: — either be fitted with attachments for lifting gear, or — be designed so that it can be fitted with such attachments, or — be shaped in such a way that standard lifting gear can easily be attached.	Please see the manual and drawings.	Y
Where machinery or one of its component parts is to be moved by hand, it must: — either be easily moveable, or — be equipped for		Y

picking up and moving safely.		
Special arrangements must be made for the handling of tools and/or machinery parts which, even if lightweight, could be hazardous.		NA
1.1.6. Ergonomics		
Under the intended conditions of use, the discomfort, fatigue and physical and psychological stress faced by the operator must be reduced to the minimum possible by allowing for the variability of the operator's physical dimensions, strength and stamina	Please see the instruction	Y
Under the intended conditions of use, the discomfort, fatigue and physical and psychological stress faced by the operator must be reduced to the minimum possible by providing enough space for movements of the parts of the operator's body		Y
Under the intended conditions of use, the discomfort, fatigue and physical and psychological stress faced by the operator must be reduced to the minimum possible by avoiding a machine-determined work rate	see the manual	Y
Under the intended conditions of use, the discomfort, fatigue and physical and psychological stress faced by the operator must be reduced to the minimum possible by avoiding monitoring that requires lengthy concentration	No this situation	Y
Under the intended conditions of use, the discomfort, fatigue and physical and psychological stress faced by the operator must be reduced to the minimum possible by adapting the man/machinery interface to the foreseeable characteristics of the operators	Please see above.	NA
1.1.7. Operating positions		
The operating position must be designed and constructed in such a way as to avoid any risk due to exhaust gases and/or lack of oxygen. If the machinery is intended to be used in a hazardous environment presenting risks to the health and safety of the operator or if the machinery itself gives rise to a hazardous environment, adequate means must be provided to ensure that the operator has good working conditions and is protected against any foreseeable hazards. Where appropriate, the operating position must be fitted with an adequate cabin designed, constructed and/or equipped to fulfill the above requirements. The exit must allow rapid evacuation. Moreover, when applicable, an emergency exit must be provided in a direction which is different from the usual exit.	The operating position is safe enough, no need of a cabin.	Y
1.1.8. Seating		
Where appropriate and where the working conditions so permit, work stations constituting an integral part of the machinery must be designed for the installation of seats. If the operator is intended to sit during operation and the operating position is an integral part of the machinery, the seat must be provided with the machinery.	No seat equipped.	NA
The operator's seat must enable him to maintain a stable position.		NA
The seat and its distance from the control devices must be capable of being adapted to the operator. Possible.		NA
If the machinery is subject to vibrations, the seat must be designed and constructed in such a way as to reduce the vibrations transmitted to the operator to the lowest level that is reasonably possible		NA
The seat mountings must withstand all stresses to which they can be subjected		NA

Where there is no floor beneath the feet of the operator, footrests covered with a slip-resistant material must be provided		NA
1.2. CONTROL SYSTEMS		
1.2.1. Safety and reliability of control systems		
Control systems must be designed and constructed in such a way that they can withstand the intended operating stresses and external influences		NA
Control systems must be designed and constructed in such a way that a fault in the hardware or the software of the control system does not lead to hazardous situations		NA
Control systems must be designed and constructed in such a way that errors in the control system logic do not lead to hazardous situations		NA
Control systems must be designed and constructed in such a way that reasonably foreseeable human error during operation does not lead to hazardous situations.		NA
The machinery must not start unexpectedly		NA
The parameters of the machinery must not change in an uncontrolled way, where such change may lead to hazardous situations		NA
The machinery must not be prevented from stopping if the stop command has already been given		NA
No moving part of the machinery or piece held by the machinery must fall or be ejected in an uncontrolled way		NA
Automatic or manual stopping of the moving parts, whatever they may be, must be unimpeded		NA
The protective devices must remain fully effective or give a stop command		NA
The safety-related parts of the control system must apply in a coherent way to the whole of an assembly of machinery and/or partly completed machinery		NA
For cable-less control, an automatic stop must be activated when correct control signals are not received, including loss of communication		NA
1.2.2. Control devices		
Control devices must be clearly visible and identifiable, using pictograms where appropriate		NA
Control devices must be positioned in such a way as to be safely operated without hesitation or loss of time and without ambiguity		NA
Control devices must be designed in such a way that the movement of the control device is consistent with its effect		NA
Control devices must be located outside the danger zones, except where necessary for certain control devices such as an emergency stop or a teach pendant		NA
Control devices must be positioned in such a way that their operation cannot cause additional risk		NA
Control devices must be designed or protected in such a way that the desired effect, where a hazard is involved, can only be achieved by		NA

a deliberate action		
Control devices must be made in such a way as to withstand foreseeable forces; particular attention must be paid to emergency stop devices liable to be subjected to considerable forces		NA
Where a control device is designed and constructed to perform several different actions, namely where there is no one-to-one correspondence, the action to be performed must be clearly displayed and subject to confirmation, where necessary		NA
Control devices must be so arranged that their layout, travel and resistance to operation are compatible with the action to be performed, taking account of ergonomic principles		NA
Machinery must be fitted with indicators as required for safe operation. The operator must be able to read them from the control position		NA
From each control position, the operator must be able to ensure that no-one is in the danger zones, or the control system must be designed and constructed in such a way that starting is prevented while someone is in the danger zone. If neither of these possibilities is applicable, before the machinery starts, an acoustic and/or visual warning signal must be given. The exposed persons must have time to leave the danger zone or prevent the machinery starting up. If necessary, means must be provided to ensure that the machinery can be controlled only from control positions located in one or more predetermined zones or locations.		NA
Where there is more than one control position, the control system must be designed in such a way that the use of one of them precludes the use of the others, except for stop controls and emergency stops		NA
When machinery has two or more operating positions, each position must be provided with all the required control devices without the operators hindering or putting each other into a hazardous situation		NA
1.2.3. Starting		
It must be possible to start machinery only by voluntary actuation of a control device provided for the purpose.	Must pull the starter pulley several times to start the engine	Y
It must only be possible to restart the machinery after a stoppage by voluntary actuation of a control device provided for the purpose		Y
It must only be possible to effect a significant change in the operating conditions by voluntary actuation of a control device provided for the purpose		Y
However, the restarting of the machinery or a change in operating conditions may be effected by voluntary actuation of a device other than the control device provided for the purpose, on condition that this does not lead to a hazardous situation.		Y
For machinery functioning in automatic mode, the starting of the machinery, restarting after a stoppage, or a change in operating conditions may be possible without intervention, provided this does not lead to a hazardous situation.		Y
Where machinery has several starting control devices and the operators can the power therefore put each other in danger, additional		NA

devices must be fitted to rule out such risks		
If safety requires that starting and/or stopping must be performed in a specific sequence, there must be devices which ensure that these operations are performed in the correct order.		Y
1.2.4. Stopping		
1.2.4.1. Normal stop		
Machinery must be fitted with a control device whereby the machinery can be brought safely to a complete stop.	Stop activity is safe.	Y
Each workstation must be fitted with a control device to stop some or all of the functions of the machinery, depending on the existing hazards, so that the machinery is rendered safe		NA
The machinery's stop control must have priority over the start controls		Y
Once the machinery or its hazardous functions have stopped, the energy supply to the actuators concerned must be cut off		Y
1.2.4.2. Operational stop		
Where, for operational reasons, a stop control that does not cut off the energy supply to the actuators is required, the stop condition must be monitored and maintained.		NA
1.2.4.3. Emergency stop		
Machinery must be fitted with one or more emergency stop devices to enable actual or impending danger to be averted unless: - the emergency device would not lessen the risk (would not reduce stopping time or would not allow measures to deal with the risk) - it is a portable hand-held and/or hand guided machine	It can stop immediately at emergency situation.	Y
The emergency stop must be clearly identifiable, clearly visible and quickly accessible		Y
The emergency stop must stop the hazardous process as quickly as possible, without creating additional risks,		Y
Where necessary, the emergency stop device must trigger or permit the triggering of certain safeguard movements		NA
Once active operation of the emergency stop device has ceased following a stop command, that command must be sustained by engagement of the emergency stop device until that engagement is specifically overridden		Y
It must not be possible to engage the emergency stop device without triggering a stop command		Y
it must be possible to disengage the emergency stop device only by an appropriate operation		Y
Disengaging the emergency stop device must not restart the machinery but only permit restarting		Y
The emergency stop function must be available and operational at all times, regardless of the operating mode		Y
Emergency stop devices must be a back-up to other safeguarding measures and not a substitute for them		Y

1.2.4.4. Assembly of machinery		
In the case of machinery or parts of machinery designed to work together, the machinery must be designed and constructed in such a way that the stop controls, including the emergency stop devices, can stop not only the machinery itself but also all related equipment, if its continued operation may be dangerous		Y
1.2.5. Selection of control or operating modes		
The control or operating mode selected must override all other control or operating modes, with the exception of the emergency stop.		NA
If machinery has been designed and constructed to allow its use in several control or operating modes requiring different protective measures and/or work procedures, it must be fitted with a mode selector which can be locked in each position. Each position of the selector must be clearly identifiable and must correspond to a single operating or control mode		NA
The mode selector may be replaced by another selection method which restricts the use of certain functions of the machinery to certain categories of operator		NA
If, for certain operations, the machinery must be able to operate with a guard displaced or removed and/or a protective device disabled, the control or operating mode selector must simultaneously: - disable all other control or operating modes		NA
- permit operation of hazardous functions only by control devices requiring sustained action		
- permit the operation of hazardous functions only in reduced risk conditions while preventing hazards from linked sequences		NA
- prevent any operation of hazardous functions by voluntary or involuntary action on the machine's sensors		NA
If these four conditions cannot be fulfilled simultaneously, the control or operating mode selector must activate other protective measures designed and constructed to ensure a safe intervention zone.		NA
In addition, the operator must be able to control operation of the parts he is working on from the adjustment point		NA
1.2.6. Failure of the power supply		
The interruption, the re-establishment after an interruption or the fluctuation in whatever manner of the power supply to the machinery must not lead to dangerous situations.	It is gasoline engine	NA
Following an interruption or change in the power supply, the machinery must not start unexpectedly		NA
Following an interruption or change in the power supply, the parameters of the machinery must not change in an uncontrolled way when such change can lead to hazardous		NA
Following an interruption or change in the power supply, the machinery must not be prevented from stopping if the command has already been given		NA

Following an interruption or change in the power supply, no moving part of the machinery or piece held by the machinery must fall or be ejected		NA
Following an interruption or change in the power supply, automatic or manual stopping of the moving parts, whatever they may be, must be unimpeded		NA
Following an interruption or change in the power supply, the protective devices must remain fully effective or give a stop command		NA
1.3. PROTECTION AGAINST MECHANICAL HAZARDS		
1.3.1. Risk of loss of stability		
Machinery and its components and fittings must be stable enough to avoid overturning, falling or uncontrolled movements during transportation, assembly, dismantling and any other action involving the machinery.	This is handhold machine	NA
If the shape of the machinery itself or its intended installation does not offer sufficient stability, appropriate means of anchorage must be incorporated and indicated in the instructions		NA
1.3.2. Risk of break-up during operation		
The various parts of machinery and their linkages must be able to withstand the stresses to which they are subject when used	Have enough strength.	Y
The durability of the materials used must be adequate for the nature of the working environment foreseen by the manufacturer or his authorized representative, in particular regarding: - fatigue - ageing - corrosion - abrasion	The main materials are cast aluminium alloy and iron.	Y
The instructions must indicate the type and frequency of inspections and maintenance required for safety reasons.	Please see the manual	Y
The instructions must, where appropriate, indicate the parts subject to wear and the criteria for replacement		Y
Where a risk of rupture or disintegration remains despite the measures taken, the parts concerned must be mounted, positioned and/or guarded in such a way that any fragments will be contained, preventing hazardous situations.		Y
Both rigid and flexible pipes carrying fluids, particularly those under high pressure, must be able to withstand the foreseen internal and external stresses and must be firmly attached and/or protected to ensure that no risk is posed by a rupture.	No high pressure in the petrol pipes and the pipes have enough strength and suppleness.	Y

Where the material to be processed is fed to the tool automatically the tool must have attained its normal working condition when it comes into contact with the workpiece.		NA
Where the material to be processed is fed to the tool automatically the feed movement and the tool movement must be coordinated when the tool starts and/or stops (intentionally or accidentally)		NA
1.3.3. Risks due to falling or ejected objects		
Precautions must be taken to prevent risks from falling or ejected objects.	No this situation	NA
1.3.4. Risks due to surfaces, edges or angles		
Insofar as their purpose allows, accessible parts of the machinery must have no sharp edges, no sharp angles and no rough surfaces likely to cause injury.	No sharp angles or rough surfaces.	Y
1.3.5. Risks related to combined machinery		
Where the machinery is intended to carry out several different operations with manual removal of the piece between each operation (combined machinery), it must be designed and constructed in such a way as to enable each element to be used separately without the other elements constituting a risk for exposed persons. To do this, it must be possible to start and stop separately any elements that are not protected	Not combined machine.	NA
1.3.6. Risks related to variations in operating conditions		
Where the machinery performs operations under different conditions of use, it must be designed and constructed in such a way that selection and adjustment of these conditions can be carried out safely and reliably		NA
1.3.7. Risks related to moving parts		
The moving parts of machinery must be designed and constructed in such a way as to prevent risks of contact which could lead to accidents or must, where risks persist, be fitted with guards or protective devices.	Necessary guards are fitted.	Y
All necessary steps must be taken to prevent accidental blockage of moving parts involved in the work. In cases where, despite the precautions taken, a blockage is likely to occur, the necessary specific protective devices and tools must, when appropriate, be provided to enable the equipment to be safely unblocked.	Refer to user manual	Y
The instructions and, where possible, a sign on the machinery shall identify these specific protective devices and how they are to be used	Refer to user manual	Y
1.3.8. Choice of protection against risks arising from moving parts		
Guards or protective devices designed to protect against risks arising from moving parts must be selected on the basis of the type of risk. The following guidelines must be used to help to make the choice.		Y

1.3.8.1. Moving transmission parts		
Guards designed to protect persons against the hazards generated by moving transmission parts must be: — either fixed guards as referred to in section 1.4.2.1, or — interlocking movable guards as referred to in section 1.4.2.2. Interlocking movable guards should be used where frequent access is envisaged.	No moving transmission parts expose of the machine.	NA
1.3.8.2. Moving parts involved in the process		
Guards or protective devices designed to protect persons against the hazards generated by moving parts involved in the process must be: — either fixed guards as referred to in section 1.4.2.1, or — interlocking movable guards as referred to in section 1.4.2.2, or — protective devices as referred to in section 1.4.3, or — a combination of the above.	Fixed guards installed.	Y
When certain moving parts directly involved in the process cannot be made completely inaccessible during operation owing to operations requiring operator intervention, such parts must be fitted with: — fixed guards or interlocking movable guards preventing access to those sections of the parts that are not used in the work, and — adjustable guards as referred to in section 1.4.2.3 restricting access to those sections of the moving parts where access is necessary		Y
1.3.9. Risks of uncontrolled movements		
When a part of the machinery has been stopped, any drift away from the stopping position, for whatever reason other than action on the control devices, must be prevented or must be such that it does not present a hazard		Y
1.4. REQUIRED CHARACTERISTICS OF GUARDS AND PROTECTIVE DEVICES		
1.4.1. General requirements		
Guards and protective devices must: - be of robust construction, - be securely held in place - not give rise to any additional hazard - not be easy to by-pass or render non-operational - be located at an adequate distance from the danger zone - cause minimum obstruction to the view of the production process - enable essential work to be carried out on the installation and/or replacement of tools and for maintenance purposes by restricting access exclusively to the area where the work has to be done, if possible without the guard having to be removed or the protective device having to be disabled	Enough strength and no risk to operators	Y
Where possible, guards must protect against the ejection or falling of materials or objects and against emissions generated by the machinery		Y
1.4.2. Special requirements for guards		

1.4.2.1. Fixed guards		
Fixed guards must be fixed by systems that can be opened or removed only with tools.	Bolts fasten	Y
Guard fixing systems must remain attached to the guards or to the machinery when the guards are removed		Y
Where possible, guards must be incapable of remaining in place without their fixings		Y
1.4.2.2. Interlocking movable guards		
Interlocking movable guards must: -as far as possible remain attached to the machinery when open - be designed and constructed in such a way that they can be adjusted only by means of an intentional action	No interlocking movable guard	NA
Interlocking movable guards must be associated with an interlocking device that prevents the start of hazardous machinery functions until they are closed		NA
Interlocking movable guards must be associated with an interlocking device that gives a stop command whenever they are no longer closed		NA
Where it is possible for an operator to reach the danger zone before the risk due to the hazardous machinery functions has ceased, movable guards must be associated with a guard locking device in addition to an interlocking device that prevents the start of hazardous machinery functions until the guard is closed and locked		NA
Where it is possible for an operator to reach the danger zone before the risk due to the hazardous machinery functions has ceased, movable guards must be associated with a guard locking device in addition to an interlocking device that keeps the guard closed and locked until the risk of injury from the hazardous machinery functions has ceased		NA
Interlocking movable guards must be designed in such a way that the absence or failure of one of their components prevents starting or stops the hazardous machinery functions		NA
1.4.2.3. Adjustable guards restricting access		
Adjustable guards restricting access to those areas of the moving parts strictly necessary for the work must be adjustable manually or automatically, depending on the type of work involved		NA
Adjustable guards restricting access to those areas of the moving parts strictly necessary for the work must be readily adjustable without the use of tools		NA
1.4.3. Special requirements for protective devices		
Protective devices must be designed and incorporated into the control system in such a way that: - moving parts cannot start up while they are within the operator's reach, - persons cannot reach moving parts while the parts are moving - the absence or failure of one of their components prevents starting or stops the moving parts		NA
Protective devices must be adjustable only by means of an intentional action		NA

1.5. RISKS DUE TO OTHER HAZARDS		
1.5.1. Electricity supply		
Where machinery has an electricity supply, it must be designed, constructed and equipped in such a way that all hazards of an electrical nature are or can be prevented. (The safety objectives set out in Directive 73/23/EEC shall apply to machinery. However, the obligations concerning conformity assessment and the placing on the market and/or putting into service of machinery with regard to electrical hazards are governed solely by this Directive.)		NA
1.5.2. Static electricity		
Machinery must be designed and constructed to prevent or limit the buildup of potentially dangerous electrostatic charges and/or be fitted with a discharging system.		NA
1.5.3. Energy supply other than electricity		
Where machinery is powered by source of energy other than electricity, it must be so designed, constructed and equipped as to avoid all potential risks associated with such sources of energy	Gasoline engine driven	Y
1.5.4. Errors of fitting		
Errors likely to be made when fitting or refitting certain parts which could be a source of risk must be made impossible by the design and construction of such parts or, failing this, by information given on the parts themselves and/or their housings. The same information must be given on moving parts and/or their housings where the direction of movement needs to be known in order to avoid a risk. Where necessary, the instructions must give further information on these risks.	Please see the manual	Y
Where a faulty connection can be the source of risk, incorrect connections must be made impossible by design or, failing this, by information given on the elements to be connected and, where appropriate, on the means of connection	No this situation	NA
1.5.5. Extreme temperatures		
Steps must be taken to eliminate any risk of injury arising from contact with or proximity to machinery parts or materials at high or very low temperatures. The necessary steps must also be taken to avoid or protect against the risk of hot or very cold material being ejected	Engine hood has a protective cover	Y
1.5.6. Fire		
Machinery must be designed and constructed in such a way as to avoid any risk of fire or overheating posed by the machinery itself or by gases, liquids, dust, vapours or other substances produced or used by the machinery	Used at outdoor	NA
1.5.7. Explosion		
Machinery must be designed and constructed in such a way as to avoid any risk of explosion posed by the machinery itself or by gases, liquids, dust, vapours or other substances produced or used by the machinery		NA
Machinery must comply, as far as the risk of explosion due to its use in a potentially explosive atmosphere is concerned, with the provisions of the specific Community Directives		NA

1.5.8. Noise		
Machinery must be designed and constructed in such a way that risks resulting from the emission of airborne noise are reduced to the lowest level, taking account of technical progress and the availability of means of reducing noise, in particular at source	The sound power level is about 105 dB(A)	Y
The level of noise emission may be assessed with reference to comparative emission data for similar machinery		Y
1.5.9. Vibrations		
Machinery must be designed and constructed in such a way that risks resulting from vibrations produced by the machinery are reduced to the lowest level, taking account of technical progress and the availability of means of reducing vibration, in particular at source.	This type machine just used for ramming the cement by vibrations	Y
The level of vibration emission may be assessed with reference to comparative emission data for similar machinery		Y
1.5.10. Radiation		
Undesirable radiation emissions from the machinery must be eliminated or be reduced to levels that do not have adverse effects on persons. Any functional ionising radiation emissions must be limited to the lowest level which is sufficient for the proper functioning of the machinery during setting, operation and cleaning. Where a risk exists, the necessary protective measures must be taken.		NA
Any functional non-ionising radiation emissions during setting, operation and cleaning must be limited to levels that do not have adverse effects on persons.		NA
1.5.11. External radiation		
Machinery must be designed and constructed in such a way that external radiation does not interfere with its operation		NA
1.5.12. Laser radiation		
Laser equipment on machinery must be designed and constructed in such a way as to prevent any accidental radiation		NA
Laser equipment on machinery must be protected in such a way that effective radiation, radiation produced by reflection or diffusion and secondary radiation do not damage health		NA
Optical equipment for the observation or adjustment of laser equipment on machinery must be such that no health risk is created by laser radiation		NA
1.5.13. Emissions of hazardous materials and substances		
Machinery must be designed and constructed in such a way that risks of inhalation, ingestion, contact with the skin, eyes and mucous membranes and penetration through the skin of hazardous materials and substances which it produces can be avoided		NA
Where a hazard cannot be eliminated, the machinery must be so equipped that hazardous materials and substances can be contained, evacuated, precipitated by water spraying, filtered or treated by another equally effective method		NA

Where the process is not totally enclosed during normal operation of the machinery, the devices for containment and/or evacuation must be situated in such a way as to have the maximum effect		NA
1.5.14. Risk of being trapped in a machine		
Machinery must be designed, constructed or fitted with a means of preventing a person from being enclosed within it or, if that is impossible, with a means of summoning help		NA
1.5.15. Risk of slipping, tripping or falling		
must be designed and constructed in such a way as to prevent persons slipping, tripping or falling on or off these parts		Y
Where appropriate, parts of the machinery where persons are liable to move about or stand must be fitted with handholds that are fixed relative to the user and that enable them to maintain their stability		Y
1.5.16. Lightning		
Machinery in need of protection against the effects of lightning while being used must be fitted with a system for conducting the resultant electrical charge to earth		NA
1.6. MAINTENANCE		
1.6.1. Machinery maintenance		
Adjustment and maintenance points must be located outside danger zones	Refer to the operating manual	Y
It must be possible to carry out adjustment, maintenance, repair, cleaning and servicing operations while machinery is at a standstill		Y
If one or more of the above conditions cannot be satisfied for technical reasons, measures must be taken to ensure that these operations can be carried out safely (see section 1.2.5)		Y
In the case of automated machinery and, where necessary, other machinery, a connecting device for mounting diagnostic fault-finding equipment must be provided		Y
Automated machinery components which have to be changed frequently must be capable of being removed and replaced easily and safely		Y
A specified operating method must be provided for removing and replacing automated machinery components which have to be changed frequently		Y
1.6.2. Access to operating positions and servicing points		
Machinery must be designed and constructed in such a way as to allow access in safety to all areas where intervention is necessary during operation, adjustment and maintenance of the machinery		Y
1.6.3. Isolation of energy sources		

Machinery must be fitted with means to isolate it from all energy sources. Such isolators must be clearly identified.		NA
Isolators must be capable of being locked if reconnection could endanger persons		NA
Isolators must also be capable of being locked where an operator is unable, from any of the points to which he has access, to check that the energy is still cut off		NA
In the case of machinery capable of being plugged into an electricity supply, removal of the plug is sufficient, provided that the operator can check from any of the points to which he has access that the plug remains removed		NA
After the energy is cut off, it must be possible to dissipate normally any energy remaining or stored in the circuits of the machinery without risk to persons		NA
As an exception to the requirement laid down in the previous paragraphs, certain circuits may remain connected to their energy sources in order, for example, to hold parts, to protect information, to light interiors, etc. In this case, special steps must be taken to ensure operator safety		NA
1.6.4. Operator intervention		
Machinery must be so designed, constructed and equipped that the need for operator intervention is limited	No need of an operator after the power switch is actuated.	Y
If operator intervention cannot be avoided, it must be possible to carry it out easily and safely		NA
1.6.5. Cleaning of internal parts		
The machinery must be designed and constructed in such a way that it is possible to clean internal parts which have contained dangerous substances or preparations without entering them	Please see the maintenance in the manual.	Y
any necessary unblocking of internal parts must also be possible from the outside		Y
If it is impossible to avoid entering the machinery, it must be designed and constructed in such a way as to allow cleaning to take place safely		N A
1.7. INFORMATION		
1.7.1. Information and warnings on the machinery		
Information and warnings on the machinery should preferably be provided in the form of readily understandable symbols or pictograms	Refer to product photo and instructions	Y

Any written or verbal information and warnings must be expressed in an official Community language or languages, which may be determined in accordance with the Treaty by the Member State in which the machinery is placed on the market and/or put into service and may be accompanied, on request, by versions in any other official Community language or languages understood by the operators.		Y
1.7.1.1. Information and information devices		
The information needed to control machinery must be provided in a form that is unambiguous and easily understood. It must not be excessive to the extent of overloading the operator.		Y
Visual display units or any other interactive means of communication between the operator and the machine must be easily understood and easy to use	No visual display	NA
1.7.1.2. Warning devices		
Where the health and safety of persons may be endangered by a fault in the operation of unsupervised machinery, the machinery must be equipped in such a way as to give an appropriate acoustic or light signal as a warning		NA
Where machinery is equipped with warning devices these must be unambiguous and easily perceived		NA
The operator must have facilities to check the operation of warning devices at all times		NA
The requirements of the specific Community Directives concerning colors and safety signals must be complied with		Y
1.7.2. Warning of residual risks		
Where risks remain despite the inherent safe design measures, safeguarding and complementary protective measures adopted, the necessary warnings, including warning devices, must be provided		Y
1.7.3. Marking of machinery		
All machinery must be marked visibly, legibly and indelibly with the following minimum particulars: - the business name and full address of the manufacturer and, where applicable, his authorized representative, - designation of the machinery - the CE Marking (see Annex III), - designation of series or type - serial number, if any - the year of construction, that is the year in which the manufacturing process is completed	Please see the nameplate.	Y
It is prohibited to pre-date or post-date the machinery when affixing the CE marking		Y
Machinery designed and constructed for use in a potentially explosive atmosphere must be marked accordingly		NA

Machinery must also bear full information relevant to its type and essential for safe use. Such information is subject to the requirements set out in section 1.7.1		Y
Where a machine part must be handled during use with lifting equipment, its mass must be indicated legibly, indelibly and unambiguously		Y
1.7.4. Instructions		
All machinery must be accompanied by instructions in the official Community language or languages of the Member State in which it is placed on the market and/or put into service	English version	Y
The instructions accompanying the machinery must be either 'Original instructions' or a 'Translation of the original instructions', in which case the translation must be accompanied by the original instructions		Y
The maintenance instructions intended for use by specialized personnel mandated by the manufacturer or his authorized representative may be supplied in only one Community language which the specialized personnel understand.		Y
1.7.4.1. General principles for the drafting of instructions		
(a) The instructions must be drafted in one or more official Community languages. The words 'Original instructions' must appear on the language version(s) verified by the manufacturer or his authorized representative.	English	Y
(b) Where no 'Original instructions' exist in the official language(s) of the country where the machinery is to be used, a translation into that/those language(s) must be provided by the manufacturer or his authorized representative or by the person bringing the machinery into the language area in question. The translations must bear the words 'Translation of the original instructions'	Please see the manual.	Y
(c) The contents of the instructions must cover not only the intended use of the machinery but also take into account any reasonably foreseeable misuse thereof		Y
(d) In the case of machinery intended for use by non-professional operators, the wording and layout of the instructions for use must take into account the level of general education and acumen that can reasonably be expected from such operators.	Please see the manual.	Y
1.7.4.2. Contents of the instructions		
Each instruction manual must contain, where applicable, at least the following information: (a) the business name and full address of the manufacturer and of his authorized representative		Y
(b) the designation of the machinery as marked on the machinery itself, except for the serial number (see section 1.7.3)		Y
(c) the EC declaration of conformity, or a document setting out the contents of the EC declaration of conformity, showing the particulars of the machinery, not necessarily including the serial number and the signature		Y
(d) a general description of the machinery		Y

(e) the drawings, diagrams, descriptions and explanations necessary for the use, maintenance and repair of the machinery and for checking its correct functioning		Y
(f) a description of the workstation(s) likely to be occupied by operators		Y
(g) a description of the intended use of the machinery		Y
(h) warnings concerning ways in which the machinery must not be used that experience has shown might occur		Y
(i) assembly, installation and connection instructions, including drawings, diagrams and the means of attachment and the designation of the chassis or installation on which the machinery is to be mounted		Y
(j) instructions relating to installation and assembly for reducing noise or vibration		Y
(k) instructions for the putting into service and use of the machinery and, if necessary, instructions for the training of operators		Y
(l) information about the residual risks that remain despite the inherent safe design measures, safeguarding and complementary protective measures adopted		Y
(m) instructions on the protective measures to be taken by the user, including, where appropriate, the personal protective equipment to be provided		Y
(n) the essential characteristics of tools which may be fitted to the machinery		NA
(o) the conditions in which the machinery meets the requirement of stability during use, transportation, assembly, dismantling when out of service, testing or foreseeable breakdowns		Y
(p) instructions with a view to ensuring that transport, handling and storage operations can be made safely, giving the mass of the machinery and of its various parts where these are regularly to be transported separately		Y
(q) the operating method to be followed in the event of accident or breakdown; if a blockage is likely to occur, the operating method to be followed so as to enable the equipment to be safely unblocked		Y
(r) the description of the adjustment and maintenance operations that should be carried out by the user and the preventive maintenance measures that should be observed		Y
(s) instructions designed to enable adjustment and maintenance to be carried out safely, including the protective measures that should be taken during these operations		Y
(t) the specifications of the spare parts to be used, when these affect the health and safety of operators		Y
(u) the following information on airborne noise emissions: — the A-weighted emission sound pressure level at workstations, where this exceeds 70 dB(A); where this level does not exceed 70 dB(A), this fact must be indicated, — the peak C-weighted instantaneous sound		Y

<p>pressure value at workstations, where this exceeds 63 Pa (130 dB in relation to 20 µPa), — the A-weighted sound power level emitted by the machinery, where the A-weighted emission sound pressure level at workstations exceeds 80 dB(A). These values must be either those actually measured for the machinery in question or those established on the basis of measurements taken for technically comparable machinery which is representative of the machinery to be produced. In the case of very large machinery, instead of the A-weighted sound power level, the A-weighted emission sound pressure levels at specified positions around the machinery may be indicated. Where the harmonized standards are not applied, sound levels must be measured using the most appropriate method for the machinery. Whenever sound emission values are indicated the uncertainties surrounding these values must be specified. The operating conditions of the machinery during measurement and the measuring methods used must be described. Where the workstation(s) are undefined or cannot be defined, A-weighted sound pressure levels must be measured at a distance of 1 meter from the surface of the machinery and at a height of 1.6 meters from the floor or access platform. The position and value of the maximum sound pressure must be indicated. Where specific Community Directives lay down other requirements for the measurement of sound pressure levels or sound power levels, those Directives must be applied and the corresponding provisions of this section shall not apply</p>		
<p>(v) where machinery is likely to emit non-ionizing radiation which may cause harm to persons, in particular persons with active or non-active implantable medical devices, information concerning the radiation emitted for the operator and exposed persons</p>		NA
<p>1.7.4.3. Sales literature</p>		
<p>Sales literature describing the machinery must not contradict the instructions as regards health and safety aspects. Sales literature describing the performance characteristics of machinery must contain the same information on emissions as is contained in the instructions</p>		Y
<p>2. SUPPLEMENTARY ESSENTIAL HEALTH AND SAFETY REQUIREMENTS FOR CERTAIN CATEGORIES OF MACHINERY</p>		
<p>Foodstuffs machinery, machinery for cosmetics or pharmaceutical products, hand-held and/or hand-guided machinery, portable fixing and other impact machinery, machinery for working wood and material with similar physical characteristics must meet all the essential health and safety requirements described in this chapter</p>		NA
<p>2.1. FOODSTUFFS MACHINERY AND MACHINERY FOR COSMETICS OR PHARMACEUTICAL PRODUCTS</p>		
<p>2.1.1. General</p>		
<p>Machinery intended for use with foodstuffs or with cosmetics or pharmaceutical products must be designed and constructed in such a way as to avoid any risk of infection, sickness or contagion. The following requirements must be observed: (a) materials in contact with, or intended to come into contact with, foodstuffs or cosmetics or pharmaceutical products must satisfy the conditions set down in the relevant Directives. The machinery must be designed and constructed in such a way that these materials can be cleaned before each use. Where this is not possible disposable parts must be used</p>	Not foodstuffs machinery	NA

(b) all surfaces and joinings in contact with foodstuffs or cosmetics or pharmaceutical products, other than surfaces of disposable parts, must be smooth and have neither ridges nor crevices which could harbour organic materials.		NA
all surfaces in contact with foodstuffs or cosmetics or pharmaceutical products, other than surfaces of disposable parts, must be designed and constructed in such a way as to reduce the projections, edges and recesses of assemblies to a minimum		NA
all surfaces in contact with foodstuffs or cosmetics or pharmaceutical products, other than surfaces of disposable parts, must be easily cleaned and disinfected, where necessary after removing easily dismantled parts; the inside surfaces must have curves with a radius sufficient to allow thorough cleaning		NA
(c) it must be possible for liquids, gases and aerosols deriving from foodstuffs, cosmetics or pharmaceutical products as well as from cleaning, disinfecting and rinsing fluids to be completely discharged from the machinery (if possible, in a 'cleaning' position)		NA
(d) machinery must be designed and constructed in such a way as to prevent any substances or living creatures, in particular insects, from entering, or any organic matter from accumulating in, areas that cannot be cleaned		NA
(e) machinery must be designed and constructed in such a way that no ancillary substances hazardous to health, including the lubricants used, can come into contact with foodstuffs, cosmetics or pharmaceutical products. Where necessary, machinery must be designed and constructed in such a way that continuing compliance with this requirement can be checked		NA
2.1.2. Instructions		
The instructions for foodstuffs machinery and machinery for use with cosmetics or pharmaceutical products must indicate recommended products and methods for cleaning, disinfecting and rinsing, not only for easily accessible areas but also for areas to which access is impossible or inadvisable		NA
2.2. PORTABLE HAND-HELD AND/OR HAND-GUIDED MACHINERY		
2.2.1. General		
Depending on the type of machinery portable hand-held and/or handguided machinery must have a supporting surface of sufficient size and have a sufficient number of handles and supports of an appropriate size, arranged in such a way as to ensure the stability of the machinery under the intended operating conditions.		Y
Except where technically impossible, or where there is an independent control device, in the case of handles which cannot be released in complete safety; portable hand-held and/or hand-guided machinery must be fitted with manual start and stop control devices arranged in such a way that the operator can operate them without releasing the handles.	This engine fitted in the machine should start with manual.	Y
Portable hand-held and/or hand-guided machinery must present no risks of accidental starting and/or continued operation after the operator has released the handles. Equivalent steps must be taken if this requirement is not technically feasible.		Y
Portable hand-held and/or hand-guided machinery must permit, where necessary, visual observation of the danger zone and of the action of the tool with the material being processed	Easy visual observation	Y

The handles of portable machinery must be designed and constructed in such a way as to make starting and stopping straightforward		NA
2.2.1.1. Instructions		
The instructions must give the following information concerning vibrations transmitted by portable handheld and hand-guided machinery: — the vibration total value to which the hand-arm system is subjected, if it exceeds 2,5 m/s ² . Where this value does not exceed 2,5 m/s ² , this must be mentioned, — the uncertainty of measurement. These values must be either those actually measured for the machinery in question or those established on the basis of measurements taken for technically comparable machinery which is representative of the machinery to be produced		Y
If harmonized standards are not applied, the vibration data must be measured using the most appropriate measurement code for the machinery.		Y
The operating conditions during measurement and the methods used for measurement, or the reference of the harmonized standard applied, must be specified.		Y
2.2.2. Portable fixing and other impact machinery		
2.2.2.1. General		
Portable fixing and other impact machinery must be designed and constructed in such a way that energy is transmitted to the impacted element by the intermediary component that does not leave the device.		Y
Portable fixing and other impact machinery must be designed and constructed in such a way that an enabling device prevents impact unless the machinery is positioned correctly with adequate pressure on the base material.		Y
Portable fixing and other impact machinery must be designed and constructed in such a way that involuntary triggering is prevented; where necessary, an appropriate sequence of actions on the enabling device and the control device must be required to trigger an impact.		Y
Portable fixing and other impact machinery must be designed and constructed in such a way that accidental triggering is prevented during handling or in case of shock.		Y
Portable fixing and other impact machinery must be designed and constructed in such a way that loading and unloading operations can be carried out easily and safely.		Y
Where necessary, it must be possible to fit the device with splinter guard(s) and the appropriate guard(s) must be provided by the manufacturer of the machinery.		Y
2.2.2.2. Instructions		
The instructions must give the necessary information regarding the accessories and interchangeable equipment that can be used with the machinery.		Y
The instructions must give the necessary information regarding the suitable fixing or other impacted elements to be used with the machinery.		Y

The instructions must give the necessary information regarding, where appropriate, the suitable cartridges to be used.		Y
2.3. MACHINERY FOR WORKING WOOD AND MATERIAL WITH SIMILAR PHYSICAL CHARACTERISTICS		
Machinery for working wood and materials with similar physical characteristics must comply with the following requirements: (a) the machinery must be designed, constructed or equipped in such a way that the piece being machined can be placed and guided in safety; where the piece is hand-held on a work-bench, the latter must be sufficiently stable during the work and must not impede the movement of the piece		NA
(b) where the machinery is likely to be used in conditions involving the risk of ejection of workpieces or parts of them, it must be designed, constructed, or equipped in such a way as to prevent such ejection, or, if this is not possible, so that the ejection does not engender risks for the operator and/or exposed persons		NA
(c) the machinery must be equipped with an automatic brake that stops the tool in a sufficiently short time if there is a risk of contact with the tool whilst it runs down		NA
(d) where the tool is incorporated into a non-fully automated machine, the machine must be designed and constructed in such a way as to eliminate or reduce the risk of accidental injury		NA
3. SUPPLEMENTARY ESSENTIAL HEALTH AND SAFETY REQUIREMENTS TO OFFSET HAZARDS DUE TO THE MOBILITY OF MACHINERY		
Machinery presenting hazards due to its mobility must meet all the essential health and safety requirements described in this chapter (see General Principles, point 4).		
3.1. GENERAL		
3.1.1. Definitions		
(a) 'Machinery presenting hazards due to its mobility' means — machinery the operation of which requires either mobility while working, or continuous or semicontinuous movement between a succession of fixed working locations, or — machinery which is operated without being moved, but which may be equipped in such a way as to enable it to be moved more easily from one place to another.		
b) 'Driver' means an operator responsible for the movement of a machine. The driver may be transported by the machinery or may be on foot, accompanying the machinery, or may guide the machinery by remote control		
3.2. WORK POSITIONS		
3.2.1. Driving position		
Visibility from the driving position must be such that the driver can, in complete safety for himself and the exposed persons, operate the machinery and its tools in their foreseeable conditions of use. Where necessary, appropriate devices must be provided to remedy hazards due to inadequate direct vision		NA
Machinery on which the driver is transported must be designed and constructed in such a way that, from the driving positions, there is no risk to the driver from inadvertent contact with the wheels and tracks		NA
The driving position of ride-on drivers must be designed and constructed in such a way that a driver's cab may be fitted, provided this does		NA

not increase the risk and there is room for it. The cab must incorporate a place for the instructions needed for the driver		
3.2.2. Seating		
Where there is a risk that operators or other persons transported by the machinery may be crushed between parts of the machinery and the ground should the machinery roll or tip over, in particular for machinery equipped with a protective structure referred to in section 3.4.3 or 3.4.4, their seats must be designed or equipped with a restraint system so as to keep the persons in their seats, without restricting movements necessary for operations or movements relative to the structure caused by the suspension of the seats. Such restraint systems should not be fitted if they increase the risk.		NA
3.2.3. Positions for other persons		
If the conditions of use provide that persons other than the driver may occasionally or regularly be transported by the machinery or work on it, appropriate positions must be provided which enable them to be transported or to work on it without risk.		NA
The second and third paragraphs of section 3.2.1 also apply to the places provided for persons other than the driver.		NA
3.3. CONTROL SYSTEMS		
If necessary, steps must be taken to prevent unauthorised use of controls.		NA
In the case of remote controls, each control unit must clearly identify the machinery to be controlled from that unit.		NA
The remote control system must be designed and constructed in such a way as to affect only: — the machinery in question, — the functions in question.		NA
Remote controlled machinery must be designed and constructed in such a way that it will respond only to signals from the intended control units.		NA
3.3.1. Control devices		
The driver must be able to actuate all control devices required to operate the machinery from the driving position, except for functions which can be safely actuated only by using control devices located elsewhere. These functions include, in particular, those for which operators other than the driver are responsible or for which the driver has to leave the driving position in order to control them safely.		NA
Where there are pedals, they must be so designed, constructed and fitted as to allow safe operation by the driver with the minimum risk of incorrect operation.		NA
Where there are pedals, they must have a slip-resistant surface and be easy to clean.		NA
Where their operation can lead to hazards, notably dangerous movements, the control devices, except for those with preset positions, must return to the neutral position as soon as they are released by the operator.		NA
In the case of wheeled machinery, the steering system must be designed and constructed in such a way as to reduce the force of sudden movements of the steering wheel or the steering lever caused by shocks to the guide wheels.		NA

Any control that locks the differential must be so designed and arranged that it allows the differential to be unlocked when the machinery is moving.		NA
The sixth paragraph of section 1.2.2, concerning acoustic and/or visual warning signals, applies only in the case of reversing.		NA
3.3.2. Starting/moving		
All travel movements of self-propelled machinery with a ride-on driver must be possible only if the driver is at the controls.		NA
Where, for operating purposes, machinery is fitted with devices which exceed its normal clearance zone (e.g. stabilisers, jib, etc.), the driver must be provided with the means of checking easily, before moving the machinery, that such devices are in a particular position which allows safe movement. This also applies to all other parts which, to allow safe movement, have to be in particular positions, locked if necessary.		NA
Where it does not give rise to other risks, movement of the machinery must depend on safe positioning of the aforementioned parts.		NA
It must not be possible for unintentional movement of the machinery to occur while the engine is being started.		NA
3.3.3. Travelling function		
Without prejudice to road traffic regulations, self-propelled machinery and its trailers must meet the requirements for slowing down, stopping, braking and immobilisation so as to ensure safety under all the operating, load, speed, ground and gradient conditions allowed for		NA
The driver must be able to slow down and stop self-propelled machinery by means of a main device.		NA
Where safety so requires, in the event of a failure of the main device, or in the absence of the energy supply needed to actuate the main device, an emergency device with a fully independent and easily accessible control device must be provided for slowing down and stopping.		NA
Where safety so requires, a parking device must be provided to render stationary machinery immobile. This device may be combined with one of the devices referred to in the second paragraph, provided that it is purely mechanical.		NA
Remote-controlled machinery must be equipped with devices for stopping operation automatically and immediately and for preventing potentially dangerous operation in the following situations: — if the driver loses control, — if it receives a stop signal, — if a fault is detected in a safety-related part of the system, — if no validation signal is detected within a specified time. Section 1.2.4 does not apply to the travelling function.		NA
3.3.4. Movement of pedestrian-controlled machinery		
Movement of pedestrian-controlled self-propelled machinery must be possible only through sustained action on the relevant control device		NA

by the drive.		
In particular, it must not be possible for movement to occur while the engine is being started.		NA
The control systems for pedestrian-controlled machinery must be designed in such a way as to minimise the risks arising from inadvertent movement of the machine towards the driver, in particular: — crushing, — injury from rotating tools.		NA
The speed of travel of the machinery must be compatible with the pace of a driver on foot.		NA
In the case of machinery on which a rotary tool may be fitted, it must not be possible to actuate the tool when the reverse control is engaged, except where the movement of the machinery results from movement of the tool. In the latter case, the reversing speed must be such that it does not endanger the driver.		NA
3.3.5. Control circuit failure		
A failure in the power supply to the power-assisted steering, where fitted, must not prevent machinery from being steered during the time required to stop it.		NA
3.4. PROTECTION AGAINST MECHANICAL HAZARDS		
3.4.1. Uncontrolled movements		
Machinery must be designed, constructed and where appropriate placed on its mobile support in such a way as to ensure that, when moved, uncontrolled oscillations of its centre of gravity do not affect its stability or exert excessive strain on its structure		NA
3.4.2. Moving transmission parts		
By way of exception to section 1.3.8.1, in the case of engines, moveable guards preventing access to the moving parts in the engine compartment need not have interlocking devices if they have to be opened either by the use of a tool or key or by a control located in the driving position, providing the latter is in a fully enclosed cab with a lock to prevent unauthorised access		NA
3.4.3. Roll-over and tip-over		
Where, in the case of self-propelled machinery with a ride-on driver, operator(s) or other person(s), there is a risk of rolling or tipping over, the machinery must be fitted with an appropriate protective structure, unless this increases the risk		NA
The protective structure must be such that in the event of rolling or tipping over it affords the ride-on person(s) an adequate deflection-limiting volume.		NA
In order to verify that the structure complies with the requirement laid down in the previous paragraph, the manufacturer or his authorised representative must, for each type of structure concerned, perform appropriate tests or have such tests performed.		NA
3.4.4. Falling objects		
Where, in the case of self-propelled machinery with a ride-on driver, operator(s) or other person(s), there is a risk due to falling objects or		NA

material, the machinery must be designed and constructed in such a way as to take account of this risk and fitted, if its size allows, with an appropriate protective structure.		
The protective structure must be such that, in the event of falling objects or material, it guarantees the ride-on person(s) an adequate deflection-limiting volume.		NA
In order to verify that the structure complies with the requirement laid down in the previous paragraph, the manufacturer or his authorised representative must, for each type of structure concerned, perform appropriate tests or have such tests performed.		NA
3.4.5. Means of access		
Handholds and steps must be designed, constructed and arranged in such a way that the operators use them instinctively and do not use the control devices to assist access		NA
3.4.6. Towing devices		
All machinery used to tow or to be towed must be fitted with towing or coupling devices designed, constructed and arranged in such a way as to ensure easy and secure connection and disconnection and to prevent accidental disconnection during use		NA
Insofar as the tow bar load so requires, such machinery must be equipped with a support with a bearing surface suited to the load and the ground		NA
3.4.7. Transmission of power between self-propelled machinery (or tractor) and recipient machinery		
Removable mechanical transmission devices linking self-propelled machinery (or a tractor) to the first fixed bearing of recipient machinery must be designed and constructed in such a way that any part that moves during operation is protected over its whole length.		NA
On the side of the self-propelled machinery (or tractor), the power take-off to which the removable mechanical transmission device is attached must be protected either by a guard fixed and linked to the self-propelled machinery (or tractor) or by any other device offering equivalent protection.		NA
It must be possible to open this guard for access to the removable transmission device. Once it is in place, there must be enough room to prevent the drive shaft damaging the guard when the machinery (or the tractor) is moving.		NA
On the recipient machinery side, the input shaft must be enclosed in a protective casing fixed to the machinery.		NA
Torque limiters or freewheels may be fitted to universal joint transmissions only on the side adjoining the driven machinery. The removable mechanical transmission device must be marked accordingly.		NA
All recipient machinery, the operation of which requires a removable mechanical transmission device to connect it to self-propelled machinery (or a tractor), must have a system for attaching the removable mechanical transmission device so that, when the machinery is uncoupled, the removable mechanical transmission device and its guard are not damaged by contact with the ground or part of the machinery.		NA
The outside parts of the guard must be so designed, constructed and arranged that they cannot turn with the removable mechanical		NA

transmission device. The guard must cover the transmission to the ends of the inner jaws in the case of simple universal joints and at least to the centre of the outer joint or joints in the case of wide-angle universal joints.		
If means of access to working positions are provided near to the removable mechanical transmission device, they must be designed and constructed in such a way that the shaft guards cannot be used as steps, unless designed and constructed for that purpose.		NA
3.5. PROTECTION AGAINST OTHER HAZARDS		
3.5.1. Batteries		
The battery housing must be designed and constructed in such a way as to prevent the electrolyte being ejected on to the operator in the event of rollover or tipover and to avoid the accumulation of vapours in places occupied by operators.		
Machinery must be designed and constructed in such a way that the battery can be disconnected with the aid of an easily accessible device provided for that purpose		
3.5.2. Fire		
Depending on the hazards anticipated by the manufacturer, machinery must, where its size permits: — either allow easily accessible fire extinguishers to be fitted, or — be provided with built-in extinguisher systems		
3.5.3. Emissions of hazardous substances		
The second and third paragraphs of section 1.5.13 do not apply where the main function of the machinery is the spraying of products. However, the operator must be protected against the risk of exposure to such hazardous emissions		
3.6. INFORMATION AND INDICATIONS		
3.6.1. Signs, signals and warnings		
All machinery must have signs and/or instruction plates concerning use, adjustment and maintenance, wherever necessary, so as to ensure the health and safety of persons. They must be chosen, designed and constructed in such a way as to be clearly visible and indelible.		
Without prejudice to the provisions of road traffic regulations, machinery with a ride-on driver must have the following equipment: — an acoustic warning device to alert persons		
— a system of light signals relevant to the intended conditions of use; the latter requirement does not apply to machinery intended solely for underground working and having no electrical power		
— where necessary, there must be an appropriate connection between a trailer and the machinery for the operation of signals		
Remote-controlled machinery which, under normal conditions of use, exposes persons to the risk of impact or crushing must be fitted with appropriate means to signal its movements or with means to protect persons against such risks. The same applies to machinery which involves, when in use, the constant repetition of a forward and backward movement on a single axis where the area to the rear of the machine is not directly visible to the driver		

Machinery must be constructed in such a way that the warning and signalling devices cannot be disabled unintentionally		
Where it is essential for safety, warning and signalling devices must be provided with the means to check that they are in good working order and their failure must be made apparent to the operator		
Where the movement of machinery or its tools is particularly hazardous, signs on the machinery must be provided to warn against approaching the machinery while it is working; the signs must be legible at a sufficient distance to ensure the safety of persons who have to be in the vicinity		
3.6.2. Marking		
The following must be shown legibly and indelibly on all machinery: — nominal power expressed in kilowatts (kW), — mass of the most usual configuration, in kilograms (kg); where appropriate: — maximum drawbar pull provided for at the coupling hook, in Newtons (N), — maximum vertical load provided for on the coupling hook, in Newtons (N).		
3.6.3. Instructions		
3.6.3.1. Vibrations		
The instructions must give the following information concerning vibrations transmitted by the machinery to the hand-arm system or to the whole body: — the vibration total value to which the hand-arm system is subjected, if it exceeds 2,5 m/s ² . Where this value does not exceed 2,5 m/s ² , this must be mentioned — the highest root mean square value of weighted acceleration to which the whole body is subjected, if it exceeds 0,5 m/s ² . Where this value does not exceed 0,5 m/s ² , this must be mentioned — the uncertainty of measurement.		
These values must be either those actually measured for the machinery in question or those established on the basis of measurements taken for technically comparable machinery which is representative of the machinery to be produced		
Where harmonised standards are not applied, the vibration must be measured using the most appropriate measurement code for the machinery concerned		
The operating conditions during measurement and the measurement codes used must be described		
3.6.3.2. Multiple uses		
The instructions for machinery allowing several uses depending on the equipment used and the instructions for the interchangeable equipment must contain the information necessary for safe assembly and use of the basic machinery and the interchangeable equipment that can be fitted.		
4. SUPPLEMENTARY ESSENTIAL HEALTH AND SAFETY REQUIREMENTS TO OFFSET HAZARDS DUE TO LIFTING OPERATIONS		
Machinery presenting hazards due to lifting operations must meet all the relevant essential health and safety requirements described in this chapter (see General Principles, point 4)		

4.1. GENERAL		
4.1.1. Definitions		
<p>(a) 'Lifting operation' means a movement of unit loads consisting of goods and/or persons necessitating, at a given moment, a change of level. (b) 'Guided load' means a load where the total movement is made along rigid or flexible guides whose position is determined by fixed points. (c) 'Working coefficient' means the arithmetic ratio between the load guaranteed by the manufacturer or his authorised representative up to which a component is able to hold it and the maximum working load marked on</p>		
Clause	Comment	Pass? Y/N/NA
<p>the component. (d) 'Test coefficient' means the arithmetic ratio between the load used to carry out the static or dynamic tests on lifting machinery or a lifting accessory and the maximum working load marked on the lifting machinery or lifting accessory. (e) 'Static test' means the test during which lifting machinery or a lifting accessory is first inspected and subjected to a force corresponding to the maximum working load multiplied by the appropriate static test coefficient and then re-inspected once the said load has been released to ensure that no damage has occurred. (f) 'Dynamic test' means the test during which lifting machinery is operated in all its possible configurations at the maximum working load multiplied by the appropriate dynamic test coefficient with account being taken of the dynamic behaviour of the lifting machinery in order to check that it functions properly. (g) 'Carrier' means a part of the machinery on or in which persons and/or goods are supported in order to be lifted.</p>		
4.1.2. Protection against mechanical hazards		
4.1.2.1. Risks due to lack of stability		
Machinery must be designed and constructed in such a way that the stability required by section 1.3.1 is maintained both in service and out of service. This must be verified		
stability must be maintained during all stages of transportation. This must be verified		
stability must be maintained during all stages of, assembly and dismantling. This must be verified		
stability must be maintained during foreseeable component failures. This must be verified		
stability must be maintained during the tests carried out in accordance with the instruction handbook. This must be verified		
4.1.2.2. Machinery running on guide rails and rail tracks		
Machinery must be provided with devices which act on the guide rails or tracks to prevent derailment.		
If, despite such devices, there remains a risk of derailment or of failure of a rail or of a running component, devices must be provided which prevent the equipment, component or load from falling or the machinery from overturning		
4.1.2.3. Mechanical strength		
Machinery, lifting accessories and their components must be capable of withstanding the stresses to which they are subjected, both in and, where applicable, out of use, under the installation and operating conditions provided for and in all relevant configurations, with due regard, where appropriate, to the effects of atmospheric factors and forces exerted by persons. This requirement must also be satisfied during transport, assembly and dismantling		
Machinery and lifting accessories must be designed and constructed in such a way as to prevent failure from fatigue and wear, taking due		

account of their intended use		
The materials used must be chosen on the basis of the intended working environments, with particular regard to corrosion, abrasion, impacts, extreme temperatures, fatigue, brittleness and ageing		
Machinery and lifting accessories must be designed and constructed in such a way as to withstand the overload in the static tests without permanent deformation or patent defect. Strength calculations must take account of the value of the static test coefficient chosen to guarantee an adequate level of safety. That coefficient has, as a general rule, the following values: (a) manually-operated machinery and lifting accessories: 1,5; (b) other machinery: 1,25		
Machinery must be designed and constructed in such a way as to undergo, without failure, the dynamic tests carried out using the maximum working load multiplied by the dynamic test coefficient. This dynamic test coefficient is chosen so as to guarantee an adequate level of safety: the coefficient is, as a general rule, equal to 1,1. As a general rule, the tests will be performed at the nominal speeds provided for. Should the control circuit of the machinery allow for a number of simultaneous movements, the tests must be carried out under the least favourable conditions, as a general rule by combining the movements concerned		
4.1.2.4. Pulleys, drums, wheels, ropes and chains		
Pulleys, drums and wheels must have a diameter commensurate with the size of the ropes or chains with which they can be fitted.		
Drums and wheels must be designed, constructed and installed in such a way that the ropes or chains with which they are equipped can be wound without coming off		
Ropes used directly for lifting or supporting the load must not include any splicing other than at their ends. Splicings are, however, tolerated in installations which are intended by design to be modified regularly according to needs of use		
Complete ropes and their endings must have a working coefficient chosen in such a way as to guarantee an adequate level of safety. As a general rule, this coefficient is equal to 5		
Lifting chains must have a working coefficient chosen in such a way as to guarantee an adequate level of safety. As a general rule, this coefficient is equal to 4		
In order to verify that an adequate working coefficient has been attained, the manufacturer or his authorised representative must, for each type of chain and rope used directly for lifting the load and for the rope ends, perform the appropriate tests or have such tests performed.		
4.1.2.5. Lifting accessories and their components		
Lifting accessories and their components must be sized with due regard to fatigue and ageing processes for a number of operating cycles consistent with their expected life-span as specified in the operating conditions for a given application		
(a) the working coefficient of wire-rope/rope-end combinations must be chosen in such a way as to guarantee an adequate level of safety; this coefficient is, as a general rule, equal to 5. Ropes must not comprise any splices or loops other than at their ends		
(b) where chains with welded links are used, they must be of the short-link type. The working coefficient of chains must be chosen in such		

a way as to guarantee an adequate level of safety; this coefficient is, as a general rule, equal to 4		
(c) the working coefficient for textile ropes or slings is dependent on the material, method of manufacture, dimensions and use. This coefficient must be chosen in such a way as to guarantee an adequate level of safety; it is, as a general rule, equal to 7, provided the materials used are shown to be of very good quality and the method of manufacture is appropriate to the intended use. Should this not be the case, the coefficient is, as a general rule, set at a higher level in order to secure an equivalent level of safety. Textile ropes and slings must not include any knots, connections or splicing other than at the ends of the sling, except in the case of an endless sling		
(d) all metallic components making up, or used with, a sling must have a working coefficient chosen in such a way as to guarantee an adequate level of safety; this coefficient is, as a general rule, equal to 4		
(e) the maximum working load of a multilegged sling is determined on the basis of the working coefficient of the weakest leg, the number of legs and a reduction factor which depends on the slinging configuration		
(f) in order to verify that an adequate working coefficient has been attained, the manufacturer or his authorised representative must, for each type of component referred to in (a), (b), (c) and (d), perform the appropriate tests or have such tests performed		
4.1.2.6. Control of movements		
Devices for controlling movements must act in such a way that the machinery on which they are installed is kept safe		
(a) Machinery must be designed and constructed or fitted with devices in such a way that the amplitude of movement of its components is kept within the specified limits. The operation of such devices must, where appropriate, be preceded by a warning		
(b) Where several fixed or rail-mounted machines can be manoeuvred simultaneously in the same place, with risks of collision, such machinery must be designed and constructed in such a way as to make it possible to fit systems enabling these risks to be avoided		
(c) Machinery must be designed and constructed in such a way that the loads cannot creep dangerously or fall freely and unexpectedly, even in the		
event of partial or total failure of the power supply or when the operator stops operating the machine		
(d) It must not be possible, under normal operating conditions, to lower the load solely by friction brake, except in the case of machinery whose function requires it to operate in that way		
(e) Holding devices must be designed and constructed in such a way that inadvertent dropping of the loads is avoided		
4.1.2.7. Movements of loads during handling		
The operating position of machinery must be located in such a way as to ensure the widest possible view of trajectories of the moving parts, in order to avoid possible collisions with persons, equipment or other machinery which might be manoeuvring at the same time and liable to constitute a hazard.		
Machinery with guided loads must be designed and constructed in such a way as to prevent persons from being injured by movement of		

the load, the carrier or the counterweights, if any		
4.1.2.8. Machinery serving fixed landings		
4.1.2.8.1. Movements of the carrier		
The movement of the carrier of machinery serving fixed landings must be rigidly guided to and at the landings. Scissor systems are also regarded as rigid guidance		
4.1.2.8.2. Access to the carrier		
Where persons have access to the carrier, the machinery must be designed and constructed in such a way as to ensure that the carrier remains stationary during access, in particular while it is being loaded or unloaded		
The machinery must be designed and constructed in such a way as to ensure that the difference in level between the carrier and the landing being served does not create a risk of tripping		
4.1.2.8.3. Risks due to contact with the moving carrier		
Where necessary in order to fulfil the requirement expressed in the second paragraph of section 4.1.2.7, the travel zone must be rendered inaccessible during normal operation		
When, during inspection or maintenance, there is a risk that persons situated under or above the carrier may be crushed between the carrier and any fixed parts, sufficient free space must be provided either by means of physical refuges or by means of mechanical devices blocking the movement of the carrier		
4.1.2.8.4. Risk due to the load falling off the carrier		
Where there is a risk due to the load falling off the carrier, the machinery must be designed and constructed in such a way as to prevent this risk		
4.1.2.8.5. Landings		
Risks due to contact of persons at landings with the moving carrier or other moving parts must be prevented		
Where there is a risk due to persons falling into the travel zone when the carrier is not present at the landings, guards must be fitted in order to prevent this risk		
Such guards must not open in the direction of the travel zone		
Guards must be fitted with an interlocking device controlled by the position of the carrier that prevents: — hazardous movements of the carrier until the guards are closed and locked, — hazardous opening of a guard until the carrier has stopped at the corresponding landing.		
4.1.3. Fitness for purpose		
When lifting machinery or lifting accessories are placed on the market or are first put into service, the manufacturer or his authorised representative must ensure, by taking appropriate measures or having them taken, that the machinery or the lifting accessories which are		

ready for use, whether manually or power-operated, can fulfil their specified functions safely		
The static and dynamic tests referred to in section 4.1.2.3 must be performed on all lifting machinery ready to be put into service. Where the machinery cannot be assembled in the manufacturer's premises or in the premises of his authorised representative, the appropriate measures must be taken at the place of use		
4.2. REQUIREMENTS FOR MACHINERY WHOSE POWER SOURCE IS OTHER THAN MANUAL EFFORT		
4.2.1. Control of movements		
Hold-to-run control devices must be used to control the movements of the machinery or its equipment. However, for partial or complete movements in which there is no risk of the load or the machinery colliding, the said devices may be replaced by control devices authorising automatic stops at pre-selected positions without the operator holding a hold-to-run control device		
4.2.2. Loading control		
Machinery with a maximum working load of not less than 1 000 kilograms or an overturning moment of not less than 40 000 Nm must be fitted with devices to warn the driver and prevent dangerous movements in the event: — of overloading, either as a result of the maximum working load or the maximum working moment due to the load being exceeded, or — of the overturning moment being exceeded		
4.2.3. Installations guided by ropes		
Rope carriers, tractors or tractor carriers must be held by counterweights or by a device allowing permanent control of the tension		
4.3. INFORMATION AND MARKINGS		
4.3.1. Chains, ropes and webbing		
Each length of lifting chain, rope or webbing not forming part of an assembly must bear a mark or, where this is not possible, a plate or irremovable ring bearing the name and address of the manufacturer or his authorised representative and the identifying reference of the relevant certificate		
The certificate mentioned above must show at least the following information: (a) the name and address of the manufacturer and, if appropriate, his authorised representative; (b) a description of the chain or rope which includes: — its nominal size, — its construction, — the material from which it is made, and — any special metallurgical treatment applied to the material; (c) the test method used; (d) the maximum load to which the chain or rope should be subjected in service. A range of values may be given on the basis of the intended applications		
4.3.2. Lifting accessories		
Lifting accessories must show the following particulars: — identification of the material where this information is needed for safe use, — the maximum working load.		
In the case of lifting accessories on which marking is physically impossible, the particulars referred to in the first paragraph must be		

displayed on a plate or other equivalent means and securely affixed to the accessory		
The particulars must be legible and located in a place where they are not liable to disappear as a result of wear or jeopardise the strength of the accessory		
4.3.3. Lifting machinery		
The maximum working load must be prominently marked on the machinery. This marking must be legible, indelible and in an un-coded form		
Where the maximum working load depends on the configuration of the machinery, each operating position must be provided with a load plate indicating, preferably in diagrammatic form or by means of tables, the working load permitted for each configuration		
Machinery intended for lifting goods only, equipped with a carrier which allows access to persons, must bear a clear and indelible warning prohibiting the lifting of persons. This warning must be visible at each place where access is possible		
4.4. INSTRUCTIONS		
4.4.1. Lifting accessories		
Each lifting accessory or each commercially indivisible batch of lifting accessories must be accompanied by instructions setting out at least the following particulars: (a) the intended use; (b) the limits of use (particularly for lifting accessories such as magnetic or vacuum pads which do not fully comply with section 4.1.2.6(e)); (c) instructions for assembly, use and maintenance; (d) the static test coefficient used		
4.4.2. Lifting machinery		
Lifting machinery must be accompanied by instructions containing information on: (a) the technical characteristics of the machinery, and in particular: — the maximum working load and, where appropriate, a copy of the load plate or load table described in the second paragraph of section 4.3.3, — the reactions at the supports or anchors and, where appropriate, characteristics of the tracks, — where appropriate, the definition and the means of installation of the ballast; (b) the contents of the logbook, if the latter is not supplied with the machinery; (c) advice for use, particularly to offset the lack of direct vision of the load by the operator; (d) where appropriate, a test report detailing the static and dynamic tests carried out by or for the manufacturer or his authorised representative; (e) for machinery which is not assembled on the premises of the manufacturer in the form in which it is to be used, the necessary instructions for performing the measures referred to in section 4.1.3 before it is first put into service		
5. SUPPLEMENTARY ESSENTIAL HEALTH AND SAFETY REQUIREMENTS FOR MACHINERY INTENDED FOR UNDERGROUND WORK		
Machinery intended for underground work must meet all the essential health and safety requirements described in this chapter (see General Principles, point 4).		
5.1. RISKS DUE TO LACK OF STABILITY		
Powered roof supports must be designed and constructed in such a way as to maintain a given direction when moving and not slip before and while they come under load and after the load has been removed. They must be equipped with anchorages for the top plates of the individual hydraulic props		

5.2. MOVEMENT		
Powered roof supports must allow for unhindered movement of persons		
5.3. CONTROL DEVICES		
The accelerator and brake controls for movement of machinery running on rails must be hand-operated. However, enabling devices may be footoperated		
The control devices of powered roof supports must be designed and positioned in such a way that, during displacement operations, operators are sheltered by a support in place		
The control devices of powered roof supports must be protected against any accidental release		
5.4. STOPPING		
Self-propelled machinery running on rails for use in underground work must be equipped with an enabling device acting on the circuit controlling the movement of the machinery such that movement is stopped if the driver is no longer in control of the movement		
5.5. FIRE		
The second indent of section 3.5.2 is mandatory in respect of machinery which comprises highly flammable parts		
The braking system of machinery intended for use in underground workings must be designed and constructed in such a way that it does not produce sparks or cause fires		
Machinery with internal combustion engines for use in underground workings must be fitted only with engines using fuel with a low vaporising pressure and which exclude any spark of electrical origin		
5.6. EXHAUST EMISSIONS		
Exhaust emissions from internal combustion engines must not be discharged upwards		
6. SUPPLEMENTARY ESSENTIAL HEALTH AND SAFETY REQUIREMENTS FOR MACHINERY PRESENTING PARTICULAR HAZARDS DUE TO THE LIFTING OF PERSONS		
Machinery presenting hazards due to the lifting of persons must meet all the relevant essential health and safety requirements described in this chapter (see General Principles, point 4).		
6.1. GENERAL		
6.1.1. Mechanical strength		
The carrier, including any trapdoors, must be designed and constructed in such a way as to offer the space and strength corresponding to the maximum number of persons permitted on the carrier and the maximum working load		
The working coefficients for components set out in sections 4.1.2.4 and 4.1.2.5 are inadequate for machinery intended for the lifting of persons and must, as a general rule, be doubled		
Machinery intended for lifting persons or persons and goods must be fitted with a suspension or supporting system for the carrier designed and constructed in such a way as to ensure an adequate overall level of safety and to prevent the risk of the carrier falling		

If ropes or chains are used to suspend the carrier, as a general rule, at least two independent ropes or chains are required, each with its own anchorage		
6.1.2. Loading control for machinery moved by power other than human strength		
The requirements of section 4.2.2 apply regardless of the maximum working load and overturning moment, unless the manufacturer can demonstrate that there is no risk of overloading or overturning		
6.2. CONTROL DEVICES		
Where safety requirements do not impose other solutions, the carrier must, as a general rule, be designed and constructed in such a way that persons in the carrier have means of controlling upward and downward movements and, if appropriate, other movements of the carrier		
In operation, those control devices must override any other devices controlling the same movement with the exception of emergency stop devices		
The control devices for these movements must be of the hold-to-run type except where the carrier itself is completely enclosed		
6.3. RISKS TO PERSONS IN OR ON THE CARRIER		
6.3.1. Risks due to movements of the carrier		
Machinery for lifting persons must be designed, constructed or equipped in such a way that the acceleration or deceleration of the carrier does not engender risks for persons.		
6.3.2. Risk of persons falling from the carrier		
The carrier must not tilt to an extent which creates a risk of the occupants falling, including when the machinery and carrier are moving		
Where the carrier is designed as a work station, provision must be made to ensure stability and to prevent hazardous movements		
If the measures referred to in section 1.5.15 are not adequate, carriers must be fitted with a sufficient number of suitable anchorage points for the number of persons permitted on the carrier. The anchorage points must be strong enough for the use of personal protective equipment against falls from a height		
Any trapdoor in floors or ceilings or side doors must be designed and constructed in such a way as to prevent inadvertent opening and must open in a direction that obviates any risk of falling, should they open unexpectedly		
6.3.3. Risk due to objects falling on the carrier		
Where there is a risk of objects falling on the carrier and endangering persons, the carrier must be equipped with a protective roof		
6.4. MACHINERY SERVING FIXED LANDINGS		
6.4.1. Risks to persons in or on the carrier		
The carrier must be designed and constructed in such a way as to prevent risks due to contact between persons and/or objects in or on the carrier with any fixed or moving elements. Where necessary in order to fulfil this requirement, the carrier itself must be completely		

enclosed with doors fitted with an interlocking device that prevents hazardous movements of the carrier unless the doors are closed. The doors must remain closed if the carrier stops between landings where there is a risk of falling from the carrier		
The machinery must be designed, constructed and, where necessary, equipped with devices in such a way as to prevent uncontrolled upward or downward movement of the carrier. These devices must be able to stop the carrier at its maximum working load and at the foreseeable maximum speed		
The stopping action must not cause deceleration harmful to the occupants, whatever the load conditions		
6.4.2. Controls at landings		
Controls, other than those for emergency use, at landings must not initiate movements of the carrier when:		
— the control devices in the carrier are being operated, — the carrier is not at a landing		
6.4.3. Access to the carrier		
The guards at the landings and on the carrier must be designed and constructed in such a way as to ensure safe transfer to and from the carrier, taking into consideration the foreseeable range of goods and persons to be lifted		
6.5. MARKINGS		
The carrier must bear the information necessary to ensure safety including: — the number of persons permitted on the carrier, — the maximum working load		

Annex 02: Risk Assessment report (EN 12100)

Risk Assessment Strategy

To implement risk assessment and risk reduction the designer shall take the following actions, in the order given (see Figure 1):

- a) determine the limits of the machinery, which include the intended use and any reasonably foreseeable misuse thereof;
- b) identify the hazards and associated hazardous situations;
- c) estimate the risk for each identified hazard and hazardous situation;
- d) evaluate the risk and take decisions about the need for risk reduction;

The final step is related to risk reduction.

- e) eliminate the hazard or reduce the risk associated with the hazard by means of protective measures.

Follow the above steps to analyse the risks associated with machinery.

Risk assessment is always followed where possible risk reduction and iteration of the process can be required to eliminate hazards as far as practicable and to implement protective measures to reduce risks.

Protective Measures

Protective measures are the measures implemented by the designer and the user, protective measures designed into the product are generally more effective and tend to be cheaper to implement.

The objective is to achieve the most practicable risk reduction taking into account the following:

- a) Safety of the machine in all the phases of the life cycle
- b) Ability of the machine to perform its function
- c) The usability of the machine
- d) The manufacturing, operational and dismantling cost of the machine

Risk reduction

Following a risk assessment risk reduction may be required. This can be achieved by the elimination of the hazard or by separately or simultaneously reducing each of the elements that determine the associated risk.

- a) Severity of harm from the hazard,
- b) Probability of the occurrence of that harm.

All protective measures that are intended to meet this objective shall be applied using the “ Three Step Method”.

Step 1: Inherently safe design measures

Inherently safe design measures eliminate hazards or reduce the associated risks by a suitable choice of design features of the machine itself and/or

interaction between the exposed persons and the machine.

NOTE 1: This stage is the only one at which hazards can be eliminated, thus avoiding the need for additional protective measures such as safeguarding or complementary protective measures.

Step 2: Safeguarding and/or complementary protective measures

Taking into account the intended use and the reasonably foreseeable misuse, appropriately selected safeguarding and complementary protective measures can be used to reduce risk when it is not practicable to eliminate a hazard, or reduce its associated risk sufficiently, using inherently safe design measures.

Step 3: Information for use

Where risks remain despite inherently safe design measures, safeguarding and the adoption of complementary protective measures, the residual risks shall be identified in the information for use. The information for use shall include, but not be limited to, the following:

- Operating procedures for the use of the machinery consistent with the expected ability of personnel who use the machinery or other persons who can be exposed to the hazards associated with the machinery.

- The recommended safe working practices for the use of the machinery and the related training requirements adequately described.

- Sufficient information, including warning of residual risks for the different phases of the life of the machinery.

- The description of any recommended personal protective equipment, including detail as to its need as well as to training needed for its use.

Information for use shall not be a substitute for the correct application of inherently safe design measures, safeguarding or complementary protective measures.

NOTE 2: Adequate protective measures associated with each of the operating modes and intervention procedures reduce the possibility of operators being induced to use hazardous intervention techniques in case of technical difficulties.

Prior to beginning work the first time, the operators are expected to have read and understood the safety section of the instructions that accompany the machinery, and to be familiar with the location and operation of each control, and to have received appropriate training / competence assessment.

Risk Estimation

Hazards should be assessed at all phases of the machine life i.e. construction, transportation, assembly, installation, commissioning, use, maintenance, dismantling & disposal.

Risk is a function of the combination of the **severity of harm** and the **probability of occurrence** of that harm. Information taken from the determined limits of the machinery will allow the risk assessor to correctly estimate the risks.

The severity of harm is estimated by considering the *severity of injury* or damage to health and the *extent of the harm* . The probability of occurrence is itself a function of the *exposure of person (s)* to the hazard, the *occurrence of a hazardous event* and the *possibility to avoid* or limit the harm.

Severity of Harm

When completing risk assessments, the risk from the most likely severity of harm that is likely to occur from each identified hazard shall be considered and the highest foreseeable severity shall also be taken into account, even if the probability is low.

The **severity of harm** can be distinguished in better detail by considering the **severity of injury** and the **extent of that harm**.

Probability of Occurrence of that harm

This is a combination of factors that can be split into the **Frequency of Exposure** and **Possibility of Avoidance**.

The frequency of exposure takes into account the *frequency of access, the nature of access, the number of persons* requiring access to the hazard zone and the *time spend within the hazard zone* . Also there are other element to identification of possibility of avoidance which considers the machines history (reliability / known problems) and the type of machine by using comparison of risks to similar machines.

The possibility of avoidance considers the skill of the operators / persons exposed to the harm, how quickly the hazardous situation develops and how easy it is for the operator / persons exposed to the harm to identify a risk.

The risk score is calculated by multiplying: severity of injury x extent of harm, frequency of exposure x possibility of avoidance using the following scoring system:

	Rating	Description	Score
Severity of Injury SOI	High	irreversible e.g. loss of limb, or fatality	3
	Medium	recoverable e.g. broken bone or deep cuts	2
	Low	reversible, minor cuts and bruises	1
Extent of Harm EOH	Several	Multiple persons exposed to hazard	2
	One	Single person exposed to hazardous situation	1
Frequency of Exposure FOE	High	frequent e.g. more than once every 10 minutes	3
	Medium	regularly e.g. once per hour	2
	Low	infrequent e.g. once per week	1
Possibility of Avoidance POA	High	obvious and slow moving	1
	Medium	can get out of the way with normal reactions	2
	Low	hazard not obvious and moving fast	3

Note: The scoring for Possibility of Avoidance is reversed from the other 2 categories.

For each hazard the objective is to get to a risk score of 4 or less.

Once the risk has been assessed, appropriate elimination and reduction measures should be taken and the risk rating recalculated.

Risk reduction can be done by separately or simultaneously reducing each of the elements which determine the risk, SOI, EOH, FOE and POA. The measures taken should be reevaluated to check if they have introduced any new hazards.

The risk assessment process should be repeated until an acceptable risk level is achieved. This called an “iterative” process.

Hazard ID #	EHSR	EN 12100 Clause	Generic Hazards	Actual Hazard – inclocation, activity & persons at risk	Risk Estimation					Measures taken to eliminate or reduce risk	Risk Re - estimation					Residual Risks – information provided & warning labels	
					SOI	EOH	FOE	POA	RISK		SOI	EOH	FOE	POA	RISK		
1			Mechanical														
1.1	1.3.7	6.2.2.1 6.2.2.2	Crushing														
1.2	1.3.4	6.2.2.1 6.2.2.2	Cutting or severing	Closing the blades - when the machine working - cutting or severing	2	1	2	2	8	Safety guard provided	1	1	2	1	2	Low risk but warning label required. (See instruction manual). Residual risk highlighted in the manual.	
1.3	1.3.7	6.2.2.1 6.2.2.2	Drawing-in or trapping	Closing the transmission device - when the machine working - hands drawing-in the machine	2	1	2	2	8	Safety guard provided	1	1	2	1	2	Low risk but warning label required. (See instruction manual). Residual risk highlighted in the manual.	
1.4	1.3.7	6.2.2.1 6.2.2.2	Entanglement	Closing the transmission device - when the machine working - hair or clothing entanglement	2	1	2	2	8	Safety guard provided	1	1	2	1	2	Low risk but warning label required. (See instruction manual). Residual risk highlighted in the manual.	
1.5	1.3.4	6.2.2.1 6.2.2.2	Friction or abrasion														
1.6	1.3.3	6.2.2.1 6.2.2.2	Impact														
1.7	1.3.2	6.2.10	Injection (e.g. high pressure fluids)														
1.8	1.3.7	6.2.2.1	Shearing														
1.10	1.5.15	6.3.5.6	Sliping, tripping and falling														
1.11	1.3.4	6.2.2.1	Stabbing or														

Hazard ID #	EHSR	EN 12100 Clause	Generic Hazards	Actual Hazard – inclocation, activity & persons at risk	Risk Estimation					Measures taken to eliminate or reduce risk	Risk Re - estimation					Residual Risks – information provided & warning labels
					SOI	EOH	FOE	POA	RISK		SOI	EOH	FOE	POA	RISK	
											Users Must be Warned of Residual Risks					
2.10	1.5.15	6.3.5.6	Falling / being thrown (e.g. during electrocution)													
3			Thermal													
3.1	1.5.5	6.2.3	Burn													
3.2	1.1.6	6.2.8	Dehydration													
3.3	1.1.6	6.2.8	Discomfort													
3.4	1.5.5	6.2.9	Frostbite													
3.5	1.5.5	6.2.3	Injuries by the radiation of heat sources													
3.6	1.5.5	6.2.3	Scald	Touching the exhaust pipe -when the engine running- injury to hands	2	1	3	3	18	Fully guard installed around the exhaust pipe.	1	1	1	1	1	low risk but warning labels required.(see reference information in the instruction handbook)
4			Noise													
4.1	1.5.8	6.2.2.2	Permanent hearing loss													
4.2	1.5.8	6.2.2.2	Tinnitus													
4.3	1.5.8	6.2.2.2 6.2.8	Interference of speech	Closing the machine- when it is working - interference of speech	1	2	3	3	18	The low noise design considered. The operators must wear earmuffs or similar device to reduce risk.	1	2	1	1	2	Warning labels required.(see reference information in the instruction handbook)
4.4	1.1.6	6.2.8	Loss of awareness													
4.5	1.1.6	6.2.8	Loss of balance													

Hazard ID #	EHSR	EN 12100 Clause	Generic Hazards	Actual Hazard – inclocation, activity & persons at risk	Risk Estimation					Measures taken to eliminate or reduce risk	Risk Re - estimation					Residual Risks – information provided & warning labels
					SOI	EOH	FOE	POA	RISK		SOI	EOH	FOE	POA	RISK	
					SOI	EOH	FOE	POA	RISK						Users Must be Warned of Residual Risks	
4.6	1.1.6	6.2.8	Discomfort	Closing the machine- when it is working - cause discomfort to people's hearing	1	2	3	3	18	The low noise design considered. The operators must wear earmuffs or similar device to reduce risk.	1	2	1	1	2	Warning labels required.(see reference information in the instruction handbook)
4.7	1.1.6	6.2.8	Stress													
5			Vibration													
5.1	1.5.9	6.2.3 6.3.4.3	Handheld													
5.2	1.5.9	6.2.3 6.3.4.3	Whole body													
5.3	1.5.9	6.2.3 6.3.4.3	Discomfort													
5.4	1.5.9	6.2.3 6.3.4.3	Low-back morbidity													
5.5	1.5.9	6.2.3 6.3.4.3	Neurological disorder													
5.6	1.5.9	6.2.3 6.3.4.3	Osteo-articular disorder													
5.7	1.5.9	6.2.3 6.3.4.3	Trauma of the spine													
5.8	1.5.9	6.2.3 6.3.4.3	Vascular disorder													
6			Radiation													
6.1	1.5.10	6.2.2.2 6.2.3	Ionising													
6.2	1.5.11	6.3.4.5	Low frequency electromagnetic													
6.3	1.5.10	6.2.3 6.3.4.5	Optical (e.g. infrared, ultraviolet)													

Hazard ID #	EHSR	EN 12100 Clause	Generic Hazards	Actual Hazard – inclocation, activity & persons at risk	Risk Estimation					Measures taken to eliminate or reduce risk	Risk Re - estimation					Residual Risks – information provided & warning labels
					SOI	EOH	FOE	POA	RISK		SOI	EOH	FOE	POA	RISK	
					SOI	EOH	FOE	POA	RISK						Users Must be Warned of Residual Risks	
6.4	1.5.12	6.2.3 6.3.4.5	Laser													
6.5	1.5.10	6.2.3 6.3.4.5 6.3.5.1	Radio frequency electromagnetic													
7			Material													
7.1	1.1.3 1.5.13	6.2.2.2 6.2.3 6.2.4	Breathing suffocation (aerosols, dust, fibres, fluids, gas)	/ Closing the working position - when the machine cutting floor - cement dust breathed by people	2	2	2	3	24	The machine installed water spray. The operators must put on protective clothing.	1	2	1	1	2	Low risk but warning label required. (See instruction manual). Residual risk highlighted in the manual.
7.2	1.1.3 1.5.13	6.2.2.2 6.2.3	Cancer (biological / microbiological agents)													
7.3	1.1.3	6.2.2.2 6.2.3	Corrosion													
7.4	1.1.3	6.2.2.2 6.2.3	Effects reproduction capability of													
7.5	1.1.3	6.2.2.2 6.2.4 6.3.1	Explosion													
7.6	1.1.3	6.2.2.2 6.2.3 6.2.4	Fire													
7.7	1.1.3	6.2.2.2 6.2.3	Infection sensitization mutation	/												
7.8	1.1.3 1.5.13	6.2.2.2 6.2.3	Poisoning													
8			Ergonomic													
8.1	1.1.6	6.2.8	Discomfort unhealthy postures	–												
8.2	1.1.6	6.2.8	Musculoskeletal disorder inadequate consideration of anatomy	–												
8.3	1.1.6 1.2.2	6.2.8	Fatigue													

Hazard ID #	EHSR	EN 12100 Clause	Generic Hazards	Actual Hazard – inclocation, activity & persons at risk	Risk Estimation					Measures taken to eliminate or reduce risk	Risk Re - estimation					Residual Risks – information provided & warning labels
					SOI	EOH	FOE	POA	RISK		SOI	EOH	FOE	POA	RISK	
			temperature												Users Must be Warned of Residual Risks	

Annex 03: Assessment report (EN 13862)



Notes of this document



It has been agreed that compliance with the EN 13862:2021 Floor cutting-off machines - Safety.

This part of EN 13862 provides requirements and recommendations relating to the Machinery Safety Requirements relating to the design and construction of machinery so as to promote:

- safety of persons and property;
- consistency of control response;
- ease of maintenance.

Clause	Requirements	Verdict	Remark
1	Scope		
	This European Standard deals with all significant hazards pertinent to floor sawing machines, when they are used as intended and under the conditions foreseen by the manufacturer (see clause 4). This European Standard specifies the appropriate technical measures to eliminate or reduce risks arising from the significant hazards. These machines are designed for use with rotating cutting-off wheels for wet and dry cutting. These cutting-off wheels can be either a diamond cutting-off wheel or a boron nitride cutting-off wheel.	P	The series floor saws are within the scope of this standard.
	This European Standard covers electrical hazards by making reference to relevant European Standards (see 5.2). Those hazards that are relevant for all mechanical, electrical, hydraulic and other equipment or machinery and that are dealt with in standards for common use are not covered by this European Standard. Reference to pertinent standards is made where such standards are applicable and so far necessary.		Electrical hazards are not applicable. Main hazards come from mechanical parts.
	This European Standard applies primarily to machines which are manufactured after the date of approval of the standard by CEN.	P	
5	Safety requirements and/or measures		
5.1	Mechanical hazards		
5.1.1	General		
	As components and parts have to be manually handled, all the accessible parts, the tool excepted, shall not present sharp edges or angles/corners which could generate hazards when setting, using, handling, and maintaining the machine. Burrs resulting from, for example, manufacturing, casting or welding shall be eliminated and sharp edges shall be smoothed.	P	No such sharp edges or angles/corners exist.

Clause	Requirements	Verdict	Remark
5.1.2	Protection against moving parts		
5.1.2.1	Transmission parts		
	Rotating transmission parts, for example drive shafts, couplings, belt drives shall be provided with fixed guards to prevent contact.	P	Rotating transmission parts equipped fixed guard. 
	Fixed guards shall be held in position either by welding or by mounting them in such a way that they can be opened or removed only with the aid of tools or keys.	P	The guard as above picture need spanner. The machine provides a spanner. 
	Guards shall comply with the provisions of EN 294:1992 on safety distances.	P	
5.1.2.2	Connection between the cutting head and the frame		
	When the vertical movement of the cutting head with respect to the frame is power driven, safety distances according to EN 294:1992 shall be provided.	NA	Hand-operated for the tool height

Clause	Requirements	Verdict	Remark
			<p>adjustment.</p> 
5.1.2.3	Protection of the tool		
5.1.2.3.1	General		
	Machines shall be equipped with a guard covering at least the upper half of the tool(s) and its fixing device(s) (see figure C.1).	P	
	Specifications concerning the strength of the guards are given in annex C.	P	
	The guard(s) shall be so designed to facilitate safe and easy access for tool replacement.	P	
	When the tool guard is removable to allow access to the tool fixing device, the machine shall be so designed that the rotation of the tool(s) may not be possible without the guard. The following exception is possible.	P	<p>The key need for starting the engine. And a safety pin used for block the tool.</p>

Clause	Requirements	Verdict	Remark
	The presence of a device for stopping the tool(s) is not necessary when the absence or the opening of the guard creates a projection of water, which prevents the intended use of the machine. The guard shall remain fixed to the machine also in the open position and a warning sign (see figure D.3) shall be provided at the guard.	P	Water projection for cooling the tool. 
5.1.2.3.2	Open parts in the guard		
	When the guard is designed with a section which can be opened at the front in order to visually position the rotating tool in relation with the cutting line, or to allow it to perform a cut close to a vertical surface, then: - the open section shall stay connected to the main guard; - the retaining device of the rotating tool(s) shall remain covered.	NA	No open part.
5.1.2.3.3	Complementary requirements to prevent contact with the tool(s) out of the cutting area		
	Contact with the tool(s) in rotation during the displacement of the machine outside the cutting area shall be prevented as follows: - either all parts of the tool(s) (in particular the lower part) shall be guarded when the machine is set for displacement or; - if the tool(s) is(are) not completely guarded, the machine shall be designed to allow displacement without the tool rotating, for example by means of a clutch and the guard shall carry a warning sign stating the following: "All displacement of the machine outside the cutting area shall be carried out with the tool not in rotation" (see figure D.2).	P	The engine cannot start without pull hard several times. Also a stop pin blocks the tool.
5.1.3	Minimum strength of the guard		
	The guards for rotating tools shall be so designed to resist strains resulting from an accidental projection of a segment of the cutting-off wheel. Any brittleness damage of the guard material shall be avoided. A permanent plastic deformation of the guard resulting from stresses is acceptable as long as the guard fulfils its protective function and can be normally assembled/disassembled.	P	The guard manufactured with enough strength.

Clause	Requirements	Verdict	Remark
	The guards shall remain attached to the frame in the case of projection of segments of the cutting-off wheel.	P	
5.1.4	Immobilization, stability		
5.1.4.1	Immobilization		
	Machines whose nominal mass exceeds 100 kg shall be equipped with a device which allows their immobilization (e. g. mechanical parking brake or self-sustaining system) on a slope of 10° with the machine in a position and configuration giving the maximum load on the braked wheel(s).	NA	The sample is less than 100 kg.
5.1.4.2	Stability		
	The machines shall be designed and constructed so that they are sufficiently stable under the intended operating conditions, e.g. movement on site, cutting and parking.	P	
	This shall be verified under the most unfavorable conditions specified by the manufacturer with the machine located on a plane inclined at 10° to the horizontal and with the machine power source switched off. The immobilization means (if any) shall be in use during the test. For machines without immobilization means the wheels shall be blocked for the test. Under these test conditions the machine shall not overturn.	P	
5.1.5	Transport and handling		
	The movable parts of the machine shall be either lockable or removable to avoid any risk of shearing or crushing e.g. during handling and carrying.	P	
5.1.6	Fixing of the tool(s)		
5.1.6.1	Device for mounting the rotating tool(s)		
	The device for mounting the rotating tool(s) shall be so designed that loosening and untightening shall be possible only by an intentional manual action (e.g. retaining the rotating tool(s) on the drive spindle by a threaded nut, the thread direction of which prevents unscrewing of the nut during the cutting operation.	P	
5.1.6.2	Flanges		
5.1.6.2.1	Mounting of a cutting-off wheel		

Clause	Requirements	Verdict	Remark
	The flanges intended to mount a rotating tool shall comply with the requirements of annex B.	P	
5.1.6.2.2	Mounting of several cutting-off wheels for grooving and milling operations		
	Where the machine is designed for grooving and milling operations with several cutting-off wheels mounted on the same spindle, the manufacturer shall specify that the spacer discs which allows the width of the saw cut to be altered to make the required groove width shall have the following performance requirements: <ul style="list-style-type: none"> - when rotating, the spacer disc(s) shall be prevented from moving in relation to the cutting tools and spindle by a positive device and not only by the tightening of the flanges; - the use of multiple mounted cutting tools shall be effected without additional modification to existing guards or exchange of guards; - secure and safe fixing of the multiple tools on the spindle shall be provided. 	NA	
	The manufacturer shall indicate the limitations and intended modifications of this application in the operator's instructions.	NA	
5.1.7	Starting with a crank		
	Internal combustion engines which are hand-started using a crank shall be designed to avoid hazards caused by kick-back, for example, a safety crank shall be provided or the engine shall be fitted with an internal antikick-back device.	NA	
	Easily accessible storage facilities shall be provided for safety starting cranks.	NA	
5.1.8	Controls		
5.1.8.1	General		
	For control functions in electric systems see clauses 7, 9, 11 and 13 of EN 60204-1:2006 and for safety related parts, see EN ISO 13849-1:2008.	P	
5.1.8.2	Stop control(s)		
	The following stop control devices shall be provided at the intended operator's position: <ul style="list-style-type: none"> - a control for stopping the whole machine; 	P	

Clause	Requirements	Verdict	Remark
	- a control enabling the rotation of the tool to be stopped (see 5.1.2.3.3).		
5.1.8.3	Control for feed movement		
	Self-propelled machines (see 3.2.3) shall be equipped with a control at the operator's position which allows disengagement of the feed system.	P	
	Self-propelled machines with the exception of those with a manually started engine shall be equipped with a device that shall prevent starting the engine when the feed mode is selected (neutral start function).	P	
	Self-propelled pedestrian controlled machines whose travelling speed towards to the operator is greater than 25 m/min (1,5 km/h) shall be equipped with a "hold to run" control.	NA	Less than 25 m/min
5.1.9	Failure of the power supply		
	An interruption of the power supply and re-establishment after an interruption shall not lead to a dangerous situation in particular: - the machine shall not be restarted automatically, an intentional action shall be necessary; - the machine shall not be prevented from stopping if the stop command has been given.	P	
5.2	Electrical hazards		
	Machines with an electrical motor power < 4 kW shall fulfil the electrical safety requirements of EN 61029-1:2000	NA	Not electrical motor.
	Other machines with an electrical motor shall fulfil the electrical safety requirements of EN 60204-1:2006, in particular clauses 4, 5, 6, 14, 15 and 16. In addition to 4.4.3 of EN 60204-1:2006 these machines shall work as intended in an ambient temperature range of 0 °C to 40 °C.	NA	
	The enclosure of the electric controls shall provide a degree of protection of at least IP 54 as defined in EN 60529:1991.	NA	
5.2.2	Water pump		
	Where water is supplied by an electrical pump for flushing the tool(s) the pump shall fulfil the relevant requirements of EN 60335-1:2002 and EN 60335-2-41:2003	NA	Water supplied by gravity.
5.3	Thermal hazards		
5.3.1	Handles and other surfaces which require continuous contact shall have a surface temperature not exceeding 43 °C.	P	
5.3.2	Controls and other parts of the machine which are contacted occasionally shall meet the limits as given in 4.2 of EN ISO 13732-1:2008 according to the chosen material for a contact period up to 5 s, lowest curve.	P	
5.3.3	Hot areas which may be contacted unintentionally shall meet the levels of EN ISO 13732-1:2008 for a contact period below 1 s. These areas shall be either located at a distance greater than 120 mm from the gripping areas, or they shall be protected by shields.	P	

Clause	Requirements	Verdict	Remark
	These shields shall be designed to reduce the heat transfer from the surface to the body of the operator. This could be achieved by a structured surface, ribs or special coating.	P	A PP material guard fitted at the position of exhaust.
5.4	Exhaust fumes (and gas)		
	Internal combustion engine exhausts shall not be directed towards the operator when in the operating position as specified by the manufacturer.	P	
	This requirement is considered fulfilled when the angle of the axis of the exhaust outlet and the longitudinal axis of the machine, measured from the position of the operator, is equal to or greater than 90°.	P	The exhaust outlet is 90° from the position of the operator.
5.5	Machines having a hydraulic power transmission		
	The hydraulic system shall comply with the safety requirements of EN 982:1996.	NA	
	Hydraulic cylinders intended for erection and lifting (e.g. to raise the tool out of the cut) shall be fitted with pilot operated check valves.	NA	
	Hydraulic hoses and pipes shall be separated from electric power wiring and be guarded against hot surfaces and sharp edges.	NA	
	Pipes and hoses which have to be disconnected in operation shall be fitted with self sealing couplings. Couplings shall be marked to ensure correct reconnection.	NA	
5.6	Fluid containers		
	When filled according to manufacturer's instructions, fluid containers except water tanks, and in particular batteries, fuel system and oil tanks shall be constructed to prevent spillage when the machine is tilted as specified in the stability test (see 5.1.4).	P	Only a fuel tank assembled with the engine.
5.7	Water supply and dust emission		
	Machines intended for wet cutting shall be equipped with a water supply device. The volume of water supplied to the	P	Wet cutting.

Clause	Requirements	Verdict	Remark
	tool(s) shall be sufficient to provide adequate tool flush and dust suppression.		
	Machines intended for dry cutting shall be equipped with a dust collector located at the appropriate place and of a suitable shape and size. This device shall be capable of being connected to a dust suction device.	NA	
5.8	Rotational speed		
	Under the rated conditions of power supply specified by the machine manufacturer, the maximum rotational speed of the spindle in min-1 shall not exceed the level as marked on the machine (see 7.1).	P	
	The rotational speed of the spindle not being equipped with the tool(s) shall be measured under the conditions specified by the manufacturer.	P	
	In the case of variation of the power supply specified by the machine manufacturer, the rotational speed shall not exceed by more than 10 % the rotational speed stated on the machine.	P	
5.9	Noise		
5.9.1	Noise reduction at the design stage		
	When designing a floor sawing machine, the available information and the technical measure to reduce noise at source shall be taken into account (see e. g. EN 11688-1:1998).	P	Considered during design.
	For machines intended to be fitted with a combustion engine, a reduction in noise shall be obtained at the design stage by at least incorporation of an exhaust silencer (muffler).	NA	
5.9.2	Noise emission measurement, declaration and verification procedures		
	Measurement, declaration and verification of noise emission values shall be made according to the noise test code given in annex A.	P	Noise emission measured according annex A.
5.10	Maintenance		
	The parts of the machine which require regular maintenance shall be designed and located to be easily accessible.	P	User manual referred.
	In particular for machines with internal combustion engine: <ul style="list-style-type: none"> - the oil drain shall be designed to allow easy recovery of the used oil; - the sump drain plug shall be recognizable. 	P	

Appendix...

Airborne noise test report

I. Applicable standards

EN ISO 3744:2010 Acoustics - Determination of sound power levels and sound energy levels of noise sources using sound pressure - Engineering methods for an essentially free field over a reflecting plane

EN ISO 11201:2010 Acoustics - Noise emitted by machinery and equipment - Determination of emission sound pressure levels at a work station and at other specified positions in an essentially free field over a reflecting plane with negligible environmental corrections

II. Test instrument

- Digital Sound Level Meter: AR834
- Manufacturer: SIGMA TECHNOLOGY
- Measurement range: A weighting 30~130dB, C weighting 35~130dB
- Accuracy of measurement: ± 1.5 dB
- Frequency response: 31.5HZ-8.5KHZ
- Sampling frequency: 2 times /sec
- Digit and precision: 5Digits & 0.1dB
- AC/DC signal output

III. Measurement method and requirements

A.1 General

The grade of accuracy of this measurement method is grade 2 according to prEN ISO 3744:2010

A-weighted emission sound pressure level at the work station and sound power level emitted by the machine shall be measured at no load and maximum speed of the tool.

A.2 Measurement of the A-weighted emission sound pressure level at the working place of the operator

The A-weighted emission sound pressure level at the working place of the operator shall be measured in accordance with EN ISO 11201:2010 and under the following conditions:

- the machine shall be placed in working environmental conditions which fulfil the requirements of clause 6 of EN ISO 11201:2010, equipped with the largest possible tool as specified by the machine manufacturer, set for a cutting operation and shall be operated at no load and at the maximum speed specified by the machine manufacturer for the size of this tool;

- measurements shall be made when the motor is at its normal operating conditions (wait 10 min at least after starting);
- the microphone position shall be related to the size of the operator which is determined by $(1,75 \pm 0,05)$ m, the operator being positioned to actuate the feed control of the machine (see also 11.1 of EN ISO 11201:2010);
- 3 series of measurements shall be made. The 3 measured values shall be recorded. The arithmetic mean value of the 3 measured values shall be retained as the measured A-weighted emission sound pressure level of the machine and reported.

A.3 Determination of the sound power level emitted by the machine

The A-weighted sound power level emitted by the machine shall be measured in accordance with EN ISO 3744:2010

The operating conditions of the machine and the calculation method of the value are the same as those used for the measurement of emission sound pressure level at the work station (see A.2).

IV . Information to be recorded

Machine				
Manufacturer	Type	Dimension mm		
LUDWIG	GFS120	Diameter 300mm		
Engine Specs				
Manufacturer	Type	Power		
Honda	GX160 Air-cooled, 4-cycle, single cylinder	4.0KW		
Acoustic environment				
Description of test environment				
Air temperature	Barometric pressure	Relative humidity	Wind speed	
25 °C	1020 hPa	53%	2.6m/s	
Acoustical data				
The shape and radius of measurement surface	The area of measurement surface	Corrections for background noise K_1	environmental correction K_{2A}	Background noise
Cuboid	33.0 m2	0	0	53.5 dB(A)

V. Test report

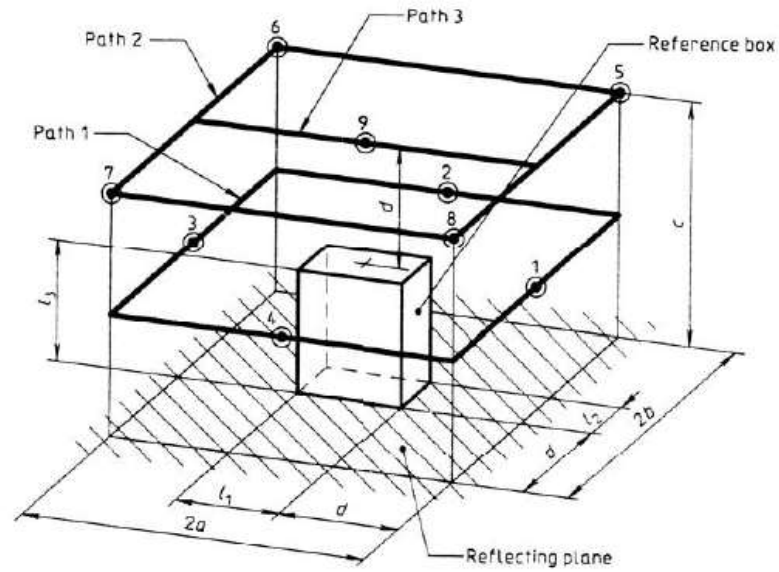

$d = 1m$

Source at maximum operating speed under no load	Test	Sound pressure level at the measurement Points (dB(A))									Sound pressure in the operating station L_{pA} (dB(A))
		2	3	4	5	6	7	8	9	L_{pAm}	1
		No.1	71.4	70.3	73.6	70.9	72.4	71.8	73.0	72.5	72.0
No.2	71.5	70.6	72.4	71.1	73.5	71.2	72.7	71.5	71.8	77.5	
No.3	72.4	71.4	73.1	71.5	73.5	72.3	73.2	71.9	72.4	77.0	
LWA= $L_{pAm} + 10 \log (S/S_0) = 87.2$ dB(A)										76.9	

Source at maximum operating speed under full load	Test	Sound pressure level at the measurement Points (dB(A))									Sound pressure in the operating station L_{pA} (dB(A))
		2	3	4	5	6	7	8	9	L_{pAm}	1
	No.1	85.2	82.3	87.2	82.1	81.6	81.7	81.8	82.4	83.0	88.5
No.2	86.2	82.7	87.6	82.8	83.1	81.2	80.4	82.6	83.3	87.5	
No.3	85.0	83.2	88.5	81.5	82.7	81.2	83.0	82.8	83.5	88.3	
$LWA = L_{pAm} + 10 \log (S/S_0) = 98.5 \text{ dB(A)}$										88.1	

Technical document list

The technical file must be made available to the competent authorities of the Member States for at least 10 years following the date of manufacture of the machinery or, in the case of series manufacture, of the last unit produced.

- A1. EC Declaration of Conformity
- A2. Specifications of models
- A3. Overall drawings
- A4. Parts list
- A5. Nameplate and warning labels
- A6. Photo of product
- A7. Operation Manual
- A8. Certificates of gasoline engine

****End of report****