

Ventiloconvectoare carcasate/necarcasate cu motoare asincron/brushless
Fan coil with Brushless DC and AC asynchronous motor



50%
50%

Economii de energie electrica
Annual savings in electricity

Reducere de nivel de zgomot
Reduction of the noise level

VERSIONI

- VMI** Verticale carcasate cu aspiratie inferioara
- VMF** Verticale carcasate cu aspiratie frontala
- OMP** Orizontale carcasate cu aspiratie posterioara
- OMI** Orizontale carcasate cu aspiratie inferioara
- VII** Verticale necarcasate cu aspiratie inferioara
- VIF** Verticale necarcasate cu aspiratie frontala
- OIP** Orizontale necarcasate cu aspiratie posterioara
- OII** Orizontale necarcasate cu aspiratie inferioara
- VIP** Verticale necarcasate cu panou decorativ P1
- VIP2** Verticale necarcasate cu panou decorativ P2
- ONP** Orizontale necarcasate cu panou decorativ

VERSIONS

- VMI** Vertical units with bottom inlet
- VMF** Vertical units with front inlet
- OMP** Horizontal units with rear inlet
- OMI** Horizontal units with bottom inlet
- VII** Fitted vertical units, bottom inlet
- VIF** Fitted vertical units, front inlet
- OIP** Fitted horizontal units, rear inlet
- OII** Fitted horizontal units, bottom inlet
- VIP** Fitted vertical units whit P1 panel
- VIP2** Fitted vertical units whit P2 panel
- ONP** Horizontal vertical units whit panel

VENTILOCONVECTOARE BRUSHLESS

- Modulatie ventilator 0-100%
- Operare super silentioase
- Beneficii majore: variatia continua 0-100% din debitul de aer (cu semnalul 0 ... 10Vdc) se reflecta in modularea puterii de incalzire si racire prin adaptarea lor instantanee la nevoile reale ale incalzirii care trebuie conditionata si asigurarea fluctuatiilor reduse ale temperaturii, umiditatii si zgomotului liniștit.

FANCOIL BRUSHLESS

- Modulating ventilation 0-100%
- Super quiet operation
- Highest well-being: the continuous variation 0-100% of the air flow (by means of the signal 0...10Vdc) is reflected in the modulation of the heating and cooling power by their instantaneous adaptation, to the actual needs of the room that to be conditioned and ensuring reduced fluctuations temperature, humidity and quiet noise.

CARACTERISTICI CONSTRUCTIVE

- Structura din tablă zincată cu carcasă preimprimată (la modelele VMI-VMF-OMP-OMI) și detalii ABS, completată cu izolație termică / fonică.
- Filtru regenerabil și colector gravitațional pentru condens. Ventilatoare centrifugale cu 6 viteze, din care 3 se pot seta in configuratia standard.
- Schimbator de caldura realizat din tevi de Cu si aripiore de Aluminiu tratate hidrofolic pentru evacuare rapida a condensului.
- Recomandare instalare kit de vane pentru fiecare unitate.

BUILDING FEATURES

- Structure galvanized sheet with prepainted covering shell (in VMI-VMF-OMP-OMI models) and ABS details, complete with heat/sound insulation
- Regenerating filter and natural discharge moisture tray.
- Centrifugal 6-speed fans type, with 3 speeds connected in the standard configuration.
- Heat exchanger in copper tubes and alluminium fins with hydrophilic surface treatment to rapid draining of moisture.
- It's recommended to use the kit valves for each type of system.



Attacchi acqua lato sinistro / Left side water sockets / Prises d'eau côté gauche
Linke Seite Wasseranschlüsse / Enganches agua lado izquierdo / Racorduri hidraulice stanga

Versiuni Versions

VMI



Verticale carcasate cu aspiratie inferioara
Vertical terminal with cabinet, bottom air intake

VMF



Verticale carcasate cu aspiratie frontala
Vertical terminal with cabinet, frontal air intake

OMP



Orizontale carcasate cu aspiratie posterioara
Horizontal terminal with cabinet, rear air intake

OMI



Orizontale carcasate cu aspiratie inferioara
Horizontal terminal with cabinet, bottom air intake

VII



Verticale necarcasate cu aspiratie inferioara
Vertical naked terminal, bottom air intake

VIF



Verticale necarcasate cu aspiratie frontala
Vertical naked terminal, front air intake

OIP



Orizontale necarcasate cu aspiratie posterioara
Horizontal naked terminal, rear air intake

OII



Orizontale necarcasate cu aspiratie inferioara
Horizontal naked terminal, bottom air intake

VIP



Verticale necarcasate cu panou decorativ (include VE/VIF, FTI, PMI, MOR, P1)
Vertical built-in terminal with panel (included VE/VIF, FTI, PMI, MOR, P1)

ONP

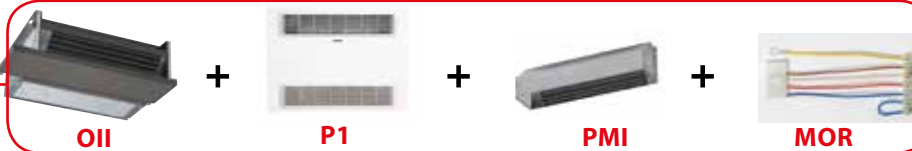

Orizontale necarcasate cu panou decorativ (include VE/OII, FTI, PMI, MOR, P1)
Horizontal built-in with panel (included VE/OII, FTI, PMI, MOR, P1)



FTI

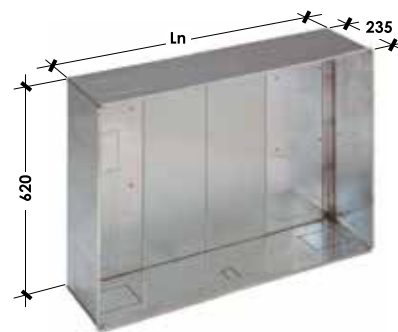
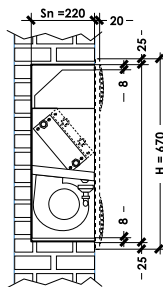
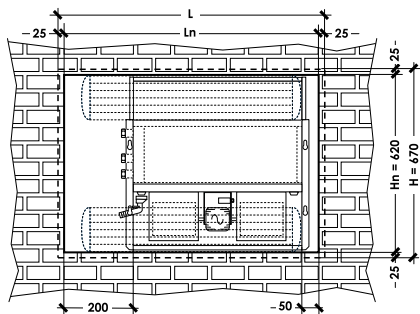

Dimensiuni - Dimensions **13/23** **33/43** **53/63** **73/83** **93/103P** **113/123P**

Ln	mm	650	850	1.050	1.250	1.450	1.650
L	mm	700	900	1.100	1.300	1.500	1.700



Placă de borne de tip mamut este inclusă pe controlerul de bord CVA-CVB-CVB-CVB-CVB. În alte cazuri trebuie comandată ca accesoriu (se monteaza in fabrica).
Mammoth type terminal board (included on the on board controller CVA-CVB-CVC-CVB-CVD) In other cases must be ordered as an accessory.

3 RANGHI I 3 ROWS I 3 RANGÉES I 3 ZELLEN I 3 BANCOS DE TUBOS I 3 RANDURI

VE		13	23	33	43	53	63	73		VE	
Pot. frigorifera / Cooling cap. / Puiss. frigorifique (1) (*)	W	1.579	2.105	2.663	3.179	3.947	4.474	5.811	W	Kühlleistung / Pot. frigorífica / Capacitate de racire (1) (*)	
Resa sensibile / Sensible capacity / Rend. sensible (1) (*)	W	1.290	1.620	2.070	2.310	2.870	3.230	4.330	W	Sensible Leistung / Cap. Sensible / Capacit. sensibila (1) (*)	
Pot. calorifica / Heating cap. / Puiss. calorifique (2) (*)	W	1.870	2.455	2.990	3.355	4.080	4.720	6.000	W	Heizleistung / Pot. calorífica / Capacit. de incalzire (2) (*)	
Pot. calorifica / Heating cap. / Puiss. calorifique (3) (*)	W	3.740	4.910	5.980	6.710	8.160	9.440	12.000	W	Heizleistung / Pot. calorífica / Capacit. de incalzire (3) (*)	
Perdite di carico / Pressure drop / Pertes de pression										Leitungsverluste / Pérdidas de carga / Cadere de presiune	
Raffreddamento / Cooling / Refroidissement (*)	kPa	14,5	18,1	20,5	23,0	25,1	26,8	27,2	kPa	Kühlung / Enfriamiento / Racire (*)	
Riscaldamento / Heating / Chauffage (3) (*)	kPa	15,9	19,2	20,1	20,0	20,9	23,2	22,6	kPa	Heizung / Calefacción / Incalzire (3) (*)	
Portata d'aria / Air flow / Débit d'air (*)	max	m³/h	370	400	500	550	670	720	1.000	m³/h	max
	med	m³/h	285	308	400	440	590	634	890	m³/h	med
	min	m³/h	226	244	305	336	462	497	650	m³/h	min
Raffreddamento / Cooling / Refroidissement (*)	l/h	272	362	458	547	679	769	999	l/h	Kühlung / Enfriamiento / Racire (*)	
Riscaldamento / Heating / Chauffage (3) (*)	l/h	322	422	514	577	702	812	1.032	l/h	Heizung / Calefacción / Incalzire (3) (*)	
Potenza assorb. / Power input / Puissance absorbée (*)	W	55	55	85	85	75	75	145	W	Leistungsaufnahme / Pot. absorbida / Put. absorbita (*)	
Press. sonora / Sound pressure / Pression sonore (4)	dB(A)	24/31/38	25/31/38	30/38/44	31/38/45	26/33/37	27/34/37	34/41/43	dB(A)	Geräuschentwicklung / Nivel de ruido / Niv. zgomot (4)	
Alimentazione / Power supply / Alimentation	V~, Ph, Hz	230, 1, 50						V~, Ph, Hz		Versorgung / Alimentación / Alimentare	
Attacchi idraulici / Water connections / Con. hydrauliques	"G	1/2"	1/2"	1/2"	1/2"	1/2"	1/2"	1/2"	"G	Hyd. Anschlüsse / Acoplam. para agua / Conexiuni	
Scarico condensa / Condensing drain / évac. condensant	mm	20	20	20	20	20	20	20	mm	Kondenswasser. / Desagüe cond. / Teava de condens.	

BATTERIA CALDA - HOT WATER EXCHANGER - RANGÉE CHAUDE - HEISSLUFTZELLE - BATERIA DE AGUA CALIENTE - BATERIE APA CALDA

VE		13	23	33	43	53	63	73		VE
Pot. calorifica / Heating cap. / Puiss. calorifique (2) (*)	W	940	990	1.590	1.675	2.190	2.275	3.145	W	Heizleistung / Pot. calorífica / Capacit. de incalzire (2) (*)
Pot. calorifica / Heating cap. / Puiss. calorifique (3) (*)	W	1.880	1.980	3.180	3.350	4.380	4.550	6.290	W	Heizleistung / Pot. calorífica / Capacit. de incalzire (3) (*)
Perdite di carico / Pressure drop / Pertes de pression (3) (*)	kPa	7,3	8,0	11,7	12,9	21,3	22,9	41,1	kPa	Leitungsverluste / Pérdidas de carga / Cadere de pres. (3) (*)

BRUSHLESS

VE		13	23	33	43	53	63	73		VE
Pot. frigorifera / Cooling cap. / Puiss. frigorifique (1)	W	1.810-880	2.320-1.130	2.830-1.400	3.220-1.600	4.630-2.130	5.070-2.330	6.010-3.060	W	Kühlleistung / Pot. frigorífica / Capacit. de racire (1)
Pot. calorifica / Heating cap. / Puiss. calorifique (2)	W	985-2.325	1.233-2.915	1.670-3.409	1.557-3.625	2.063-5.209	2.285-5.794	2.949-6.615	W	Heizleistung / Pot. calorífica / Capacit. de incalzire (2)
Pot. calorifica / Heating cap. / Puiss. calorifique (3)	W	4.680-1.970	5.860-2.470	6.840-2.940	7.250-3.120	10.510-4.130	11.650-4.580	13.280-5.900	W	Heizleistung / Pot. calorífica / Capacit. de incalzire (3)
Batteria calda / Hot water exchanger / Rangée chaude (2)	W	1.209-510	1.211-515	1.855-800	1.865-805	2.880-1.135	2.883-1.140	3.553-1.580	W	Heissluftzelle / Bateria de agua caliente / Bateria (2)
Batteria calda / Hot water exchanger / Rangée chaude (3)	W	2.440-1.030		3.730-1.610		5.800-2.280		7.140-3.170	W	Heissluftzelle / Bateria de agua caliente / Bateria (3)
Portata d'aria / Air flow / Débit d'air	m³/h	537-127		625-153		1.021-215		1.184-306	m³/h	Luftdurchflussmenge / Caudal de aire / Debit de aer
Pot. assorb. / Power input / Puiss. absorbée (5)	W	9		9		10		11	W	Leistungsaufnahme / Pot. absorbida / Put. absorbita (5)
Press. sonora / Sound pressure / Pression sonore (5)	dB(A)	23		26		22		24	dB(A)	Geräuschentwicklung / Nivel de ruido / Niv. zgomot (5)
Alimentazione / Power supply / Alimentation	V~, Ph, Hz	230, 1, 50						V~, Ph, Hz		Versorgung / Alimentación / Alimentare
Segnale / Signal / Signal	Vdc	0-10						Vdc		Signal / Señal / Semnal

Attacchi acqua lato sinistro / Left side water sockets / Prises d'eau côté gauche Linke Seite Wasseranschlüsse Enganches agua lado izquierdo Racorduri hidraulice partea stanga

Nota: Rese e portate d'aria riferite in condizioni di prevalenza 0 Pa. Per prevalenze utili diverse riferirsi ai diagrammi di variazione di portata d'aria. Note: Capacities and air flow rates referred in terms of prevalence 0 Pa. For different static pressure, refer air flow variation diagrams.

- (1) Temperatura aria in ingresso: 27°C b.s./19,5°C b.u.
Temperatura acqua in ingresso/uscita: 7°C/12°C
- (2) Temperatura aria in ingresso: 20°C b.s.
Temperatura acqua in ingresso/uscita: 45°C/40°C
- (3) Temperatura aria in ingresso: 20°C b.s.
Temperatura acqua in ingresso/uscita: 70°C/60°C
- (4) Alla distanza di 2 m e tempo di riverbero 0,5 s.
- (5) Con segnale ingresso 3Vdc
- (*) Massima velocità

- (1) Température air en entrée: 27°C b.s./19,5°C b.u.
Température eau entrée/sortie: 7°C/12°C
- (2) Température air en entrée: 20°C b.s.
Température eau entrée/sortie: 45°C/40°C
- (3) Température eau entrée/sortie: 70°C/60°C
- (4) A une distance de 2 m et avec temps de resonnance de 0,5 s
- (5) Signal d'entrée 3Vdc
- (*) Vitesse maximal
- (1) Lufttemperatur Zulauf: 27°C b.t./19,5°C b.f.
Wassertemperatur: 7°C/12°C
- (2) Lufttemperatur Zulauf: 20°C b.t.
Wassertemperatur: 45°C/40°C
- (3) Wassertemperatur: 70°C/60°C
- (4) Bei einer Entfernung von 2 m und mit Wiederhallzeit von 0,5 s
- (5) 3Vdc Eingangssignals
- (*) Höchstgeschwindigkeit

- (1) Temperatura del aire de entrada: 27°C b.s./19,5°C b.u. Temperatura del agua de entrada/salida: 7°C/12°C
- (2) Temperatura del aire de entrada: 20°C b.s.
Temperatura del agua de entrada/salida: 45°C/40°C
- (3) Temperatura del agua de entrada/salida: 70°C/60°C
- (4) En una distancia de 2 m y con tiempo de reverberación de 0,5 s
- (5) Señal de entrada 3Vdc
- (*) Máxima velocidad
- (1) Temperatura ar à entrada: 27°C b.s./19,5°C b.u.
Temperatura água à entrada/sáida: 7°C/12°C
- (2) Temperatura ar à entrada: 20°C b.s.
Temperatura água à entrada/sáida: 45°C/40°C
- (3) Temperatura água à entrada/sáida: 70°C/60°C
- (4) A uma distância de 2 m e com tempo de reverberação de 0,5 s.
- (5) Sinal de entrada 3Vdc
- (*) Velocidade máxima

3 RANGHI | 3 ROWS | 3 RANGÉES | 3 ZELLEN | 3 BANCOS DE TUBOS | 3 RANDURI

VE		83 93 103 93P 103P 113P 123P								VE		
Pot. frigorifera / Cooling cap. / Puiss. frigorifique (1) (*)	W	6.758	7.926	9.495	9.568	10.337	10.105	11.274	W	Kühlleistung / Pot. frigorífica / Capacit. de racire (1) (*)		
Resa sensibile / Sensible capacity / Rend. sensible (*)	W	4.800	5.670	6.620	6.200	7.300	7.640	8.360	W	Sensible Leistung / Cap. Sensible / Capacit. sensibila (*)		
Pot. calorifica / Heating cap. / Puiss. calorifique (2) (*)	W	6.650	7.750	9.050	8.415	9.895	10.550	11.600	W	Heizleistung / Pot. calorífica / Capac. de incalzire (2) (*)		
Pot. calorifica / Heating cap. / Puiss. calorifique (3) (*)	W	13.300	15.500	18.100	16.830	19.790	21.100	23.200	W	Heizleistung / Pot. calorífica / Capac. de incalzire (3) (*)		
Perdite di carico / Pressure drop / Pertes de pression										Leitungsverluste / Pérdidas de carga / Cadere de presiune		
Raffreddamento / Cooling / Refroidissement (*)	kPa	30,0	31,9	32,4	37,4	38,4	34,4	37,0	kPa	Kühlung / Enfriamiento / Racire (*)		
Riscaldamento / Heating / Chauffage (3) (*)	kPa	22,6	23,8	22,9	28,1	27,4	29,2	30,5	kPa	Heizung / Calefacción / Incalzire (3) (*)		
Portata d'aria / Air flow / Débit d'air (*)	max	m³/h	1.050	1.280	1.310	1.450	1.500	1.910	1.940	m³/h	max	Luftdurchflussmenge / Caudal de aire / Debit (*)
	med	m³/h	935	1.139	1.166	1.291	1.335	1.643	1.668	m³/h	med	
	min	m³/h	683	870	891	986	1020	1490	1.513	m³/h	min	
Raffreddamento / Cooling / Refroidissement (*)	l/h	1.162	1.363	1.633	1.474	1.778	1.738	1.939	l/h	Kühlung / Enfriamiento / Racire (*)		
Riscaldamento / Heating / Chauffage (3) (*)	l/h	1.144	1.333	1.557	1.447	1.702	1.815	1.995	l/h	Heizung / Calefacción / Incalzire (3) (*)		
Potenza assorb. / Power input / Puissance absorbée (*)	W	145	175	175	225	225	285	285	W	Leistungsaufnahme / Pot. absorbida / Put. absorbita (*)		
Press. sonora / Sound pressure / Pression sonore (4)	dB(A)	35/41/45	39/46/48	40/46/49	43/48/51	44/49/52	45/48/51	46/48/51	dB(A)	Geräuschentwicklung / Nivel de ruido / Nivel de zgomot (4)		
Alimentazione / Power supply / Alimentation	V~, Ph, Hz	230, 1, 50						V~, Ph, Hz		Versorgung / Alimentación / Alimentare		
Attacchi idraulici / Water connections / Con. hydrauliques	"G	1/2"	1/2"	1/2"	1/2"	1/2"	1/2"	1/2"	"G	Hyd. Anschlüsse / Acoplam. para agua / Racorduri		
Scarico condensa / Condensing drain / évac. condensant	mm	20	20	20	20	20	20	20	mm	Kondenswasser. / Desagüe cond. / Teava condens		

BATTERIA CALDA - HOT WATER EXCHANGER - RANGÉE CHAUDE - HEISLUFTZELLE - BATERIA DE AGUA CALIENTE - BATERIE APA CALDA

VE		83 93 103 93P 103P 113P 123P								VE	
Pot. Calorifica / Heating cap. / Puiss. calorifique (2) (*)	W	3.230	3.995	4.055	4.350	4.450	5.545	5.600	W	Heizleistung / Pot. calorífica / Capacit. de incalzire (2) (*)	
Pot. Calorifica / Heating cap. / Puiss. calorifique (3) (*)	W	6.460	7.990	8.110	8.700	8.900	11.090	11.200	W	Heizleistung / Pot. calorífica / Capacit. de incalzire (3) (*)	
Perdite di carico / Pressure drop / Pertes de pression (3) (*)	kPa	43,3	37,7	38,8	44,6	46,7	48,4	49,3	kPa	Leitungsverluste / Pérdidas de carga / Cadere de pres (3) (*)	

BRUSHLESS

VE		83 93 103			VE		
Pot. frigorifera / Cooling cap. / Puiss. frigorifique (1)	W	6.820-3.470		7.440-3.780	8.790-4.460	W	Kühlleistung / Pot. frigorífica / Capacit. de racire (1)
Pot. calorifica / Heating cap. / Puiss. calorifique (2)	W	2.174-7.149		3.388-7.650	3.898-8.800	W	Heizleistung / Pot. calorífica / Capacit. de incalzire (2)
Pot. calorifica / Heating cap. / Puiss. calorifique (3)	W	14.300-6350		15.300-6.780	17.600-7.800	W	Heizleistung / Pot. calorífica / Capacit. de incalzire (3)
Batteria calda / Hot water exchanger / Rangée chaude (2)	W	3.561-1.590		4.045-1.790	4.045-1.795	W	Heissluftzelle / Bateria de agua caliente / Baterie (2)
Batteria calda / Hot water exchanger / Rangée chaude (3)	W	7.140-3.170		8.090-3.590		W	Heissluftzelle / Bateria de agua caliente / Baterie (3)
Portata d'aria / Air flow / Débit d'air	m³/h	1.184-306		1.255-323		m³/h	Luftdurchflussmenge / Caudal de aire / Debit de aer
Pot. assorbita / Power input / Puiss. absorbée (5)	W	11		11		W	Leistungsaufnahme / Pot. absorbida / Put. absorbita (5)
Press. sonora / Sound pressure / Pression sonore (5)	dB(A)	24		25		dB(A)	Geräuschentwicklung / Nivel de ruido / Niv. zgomot (5)
Alimentazione / Power supply / Alimentation	V~, Ph, Hz	230, 1, 50				V~, Ph, Hz	Versorgung / Alimentación / Alimentare
Segnale / Signal / Signal	Vdc	0-10				Vdc	Signal / Señal / Semnal

Attacchi acqua lato sinistro / Left side water sockets / Prises d'eau côté gauche Linke Seite Wasseranschlüsse Enganches agua lado izquierdo Ligações água lado esquerdo

Nota: Rese e portate d'aria riferite in condizioni di prevalenza 0 Pa. Per prevalenze utili diverse riferirsi ai diagrammi di variazione di portata d'aria. Note: Capacities and air flow rates referred in terms of prevalence 0 Pa. For different static pressure, refer air flow variation diagrams.

(1) Temperatura aria in ingresso: 27°C b.s./19,5°C b.u. Temperatura acqua in ingresso/uscita: 7°C / 12°C	(1) Température air en entrée: 27 °C b.s. / 19,5 °C b.u. Température eau entrée/sortie: 7 °C/12 °C	(1) Temperatura del aire de entrada: 27°C b.s. / 19,5°C b.u. Temperatura del agua de entrada/salida: 7°C / 12°C
(2) Temperatura aria in ingresso: 20°C b.s. Temperatura acqua in ingresso/uscita: 45°C / 40°C	(2) Température air en entrée: 20 °C b.s. Température eau entrée/sortie: 45°C / 40°C	(2) Temperatura del aire de entrada: 20°C b.s. Temperatura del agua de entrada/salida: 45°C / 40°C
(3) Temperatura acqua in ingresso/uscita: 70°C / 60°C	(3) Température eau entrée/sortie: 70°C / 60°C	(3) Temperatura del agua de entrada/salida: 70°C / 60°C
(4) Alla distanza di 2 m e tempo di riverbero 0,5 s.	(4) A une distance de 2 m et avec temps de resanance de 0,5 s	(4) En una distancia de 2 m y con tiempo de resonancia de 0,5 s
(5) Con segnale ingresso 3Vdc	(5) Signal d'entrée 3Vdc	(5) Señal de entrada 3Vdc
(*) Massima velocità	(*) Vitesse maximal	(*) Máxima velocidad
(1) Entering air temperature: 27°C db./19,5°C w.b. In/Out water temperature: 7°C / 12°C	(1) Lufttemperatur Zulauf: 27°C b.t. / 19,5°C b.f. Wassertemperatur: 7°C / 12°C	(1) Temperatura ar à entrada: 27°C b.s. / 19,5°C b.u. Temperatura água à entrada/sáida: 7°C / 12°C
(2) Entering air temperature: 20°C db. In/Out water temperature: 45°C / 40°C	(2) Lufttemperatur Zulauf: 20°C b.t. Wassertemperatur: 45°C / 40°C	(2) Temperatura ar à entrada: 20°C b.s. Temperatura água à entrada/sáida: 45°C / 40°C
(3) In/Out water temperature: 70°C / 60°C	(3) Wassertemperatur: 70°C / 60°C	(3) Temperatura água à entrada/sáida: 70°C / 60°C
(4) At a distance of 2 m and with reverberation time of 0,5 s.	(4) Bei einer Entfernung von 2 m und mit Wiederhaltzeit von 0,5 s	(4) A uma distância de 2 m e com tempo de reverberação de 0,5 s.
(5) 3Vdc input signal	(5) 3Vdc Eingangssignals	(5) Sinal de entrada 3Vdc
(*) Max speed	(*) Höchstgeschwindigkeit	(*) Velocidade máxima

DIMENSIUNI DIMENSIONS

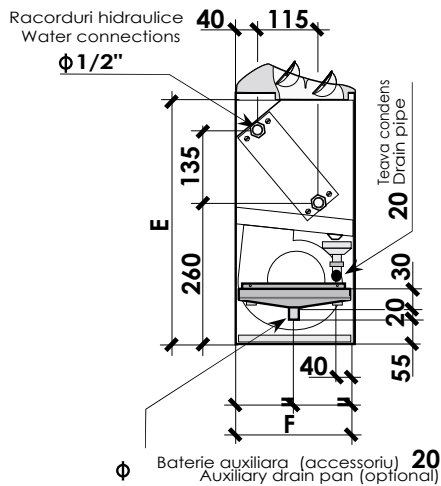
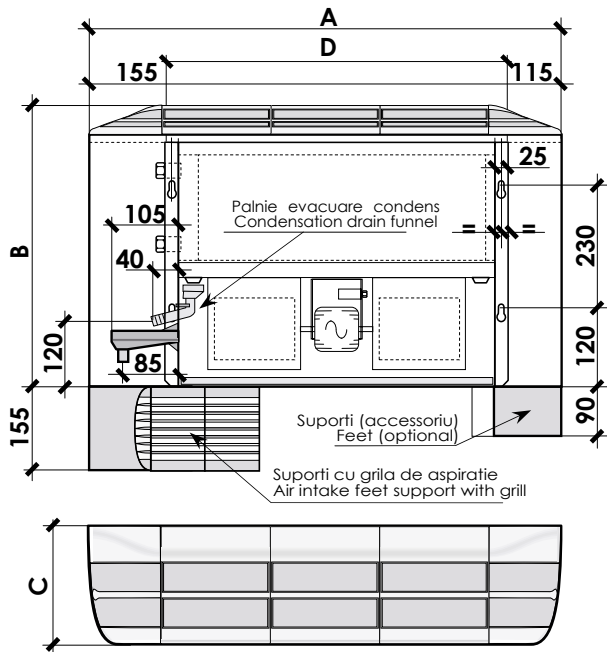

Versiuni carcasate
Versions with cabinet
B = 520 mm
C = 220 mm

Versiuni necarcasate
Versions without cabinet
B1 = 450 mm
C1 = 215 mm

Attacchi acqua lato sinistro / Left side water sockets / Prises d'eau côté gauche
Linke Seite Wasseranschlüsse / Enganches agua lado izquierdo / Racorduri partea stanga

CON MANTELLO - WITH CABINET - AVEC CARROSSERIE - EINHEITEN - CON MANTO - CARCASATE

VE		13	23	33	43	53	63	73
A *	mm	670	670	870	870	1.070	1.070	1.270
B	mm	520	520	520	520	520	520	520
C	mm	220	220	220	220	220	220	220
Peso/Weight/Poids/Gewicht/Peso/Greutate	kg	15	15,5	18,5	19	25	26	29

VE		83	93	103	93P	103P	113P	123P
A *	mm	1.270	1.470	1.470	1.470	1.470	1.670	1.670
B	mm	520	520	520	520	520	520	520
C	mm	220	220	220	220	220	220	220
Peso/Weight/Poids/Gewicht/Peso/Greutate	kg	30	34	35	35	36	39	42

* Nelle versioni orizzontali la larghezza A risulta più larga di 120 mm / * In horizontal versions the width A is larger than 120 mm / * Dans les versions horizontales la largeur A est supérieur à 120 mm / * In horizontaler Ausführung die Breite A ist größer als 120 mm / * En las versiones horizontales de la anchura A es mayor que 120 mm / * In versiunile orizontale latimea A este mai mare de 120 mm

SENZA MANTELLO - NAKED VERSION - VERSION NAKED - NACKT VERSIONEN - VERSIÓN DESNUDO - NECARCASATE

VE		13	23	33	43	53	63	73
A *	mm	425	425	625	625	825	825	1.025
B	mm	450	450	450	450	450	450	450
C	mm	215	215	215	215	215	215	215
Peso/Weight/Poids/Gewicht/Peso/Greutate	kg	11	11,6	14	15	20	21	23,5

VE		83	93	103	93P	103P	113P	123P
A *	mm	1.025	1.225	1.225	1.225	1.225	1.425	1.425
B	mm	450	450	450	450	450	450	450
C	mm	215	215	215	215	215	215	215
Peso/Weight/Poids/Gewicht/Peso/Greutate	kg	25	27,5	29	28,5	30	31	35

* Nelle versioni orizzontali la larghezza A risulta più larga di 120 mm / * In horizontal versions the width A is larger than 120 mm / * Dans les versions horizontales la largeur A est supérieur à 120 mm / * In horizontaler Ausführung die Breite A ist größer als 120 mm / * En las versiones horizontales de la anchura A es mayor que 120 mm / * In versiunile orizontale latimea A este mai mare de 120 mm



MB	Motore brushless (solo modelli 13÷103) / Brushless motor (only for models 13÷103) / Moteur Brushless (pour les modèles 13÷103) / Brushless Motor (nur für Modelle 13÷103) / Motor Brushless (sólo para los modelos 13÷103) / Motor brushless (doar pt. modelele 13-103)
BC	Batteria ausiliaria 1 rango / Auxiliary coil / Batterie auxiliare 1 rang Zusatzbatterie 1 Zeile / Bateria auxiliar 1 fila / Baterie auxiliara cu 1 rand
P	Piedini / Pedestal / Pieds-support / Füßen / Pies / Suporti de sustinere
VA	Bacinella ausiliaria per versioni verticali / Auxiliary drain pan for vertical versions / Bac de récupération d'eau pour les versions verticales / Zusatzkondensantwanne für vertikale Versionen / Drenaje auxiliar para las versiones verticales / Tava suplimentara condens versiuni verticale
CVA	Comando bordo macchina 3 velocità / OFF/3-speed switch / Selecteur de 3 vitesses de bord de l'appareil / Befehl an der Maschine in 3 Geschwindigkeiten Tarjeta de control a 3 velocidades / Panou de comanda incorporat-selector 3 viteze/Öff
CVB	Comando bordo macchina 3 velocità + commutatore estate inverno + termostato ambiente / OFF/3-speed switch Winter-Summer switch+Bulb room thermostat / Selecteur de 3 vitesses de bord de l'appareil + commutateur été-hiver + thermostat d'ambiance / Befehl an der Maschine in 3 Geschwindigkeiten + Sommer Winter Schalter + Thermostat / Tarjeta de control a 3 velocidades + interruptor verano invierno + termostato de ambiente / Panou de comanda incorporat cu 3 viteze + comutator Vara/larna + termostat ambiental
CVC	Comando elettronico bordo macchina 230Vac con OFF/Est/Inv + 3 velocità + termostato con/senza valvole / On board mounted electronic control 230Vac with off/summer/winter+3speeds+thermostat with-without valves/ Régulateur électronique de bord de l'appareil 230Vac avec OFF/été/Hiver + 3 vitesses + thermostat avec/sans vannes / elektronische Steuerkarte an der Maschine 230Vac mit OFF/Sommer/Winter + 3 Geschwindigkeiten + Thermostat ohne / mit Ventilen / Tablero de control electrónico con 230vac OFF/Verano/Invierno + 3 velocidades + termostato con/sin válvulas / Panou de comanda electronic incorporat 230 V + comutator Off/Vara/larna + selector 3 viteze + termostat cu/fara vane
CBB	Comando bordo macchina per motore brushless gestione 2/4 tubi con/senza valvole / On board brushless control 2/4pipes unit with-without valves / Régulateur de bord de l'appareil pour moteur brushless gestion 2/4 tubes avec/sans vannes / Steuerungen an der Maschine für Brushless Motor 2/4 Rohre ohne / mit Ventilen / Tarjeta de control para la gestión de motor brushless 2/4 tubos con/sin válvulas / Panou de comanda incorporat pentru motoare brushless + gestiune 2/4 tevi cu sau fara vane
CVD	Comando bordo macchina a microprocessore 230Vac + gestione 2/4 tubi con/senza valvole / On board control 230 Vac for controll 2/4 pipes unit with/without valves / Régulateur mural à microprocesseur de gestion 2/4 tubes avec/sans vannes / Steuerungen an der Maschine 2/4 Rohre ohne mit Ventilen / Tarjeta de control con microprocesador 230Vac + gestión 2/4 tubos con/sin válvulas / Panou de comanda incorporat cu microprocesor 230V + gestiune sistem 2/4 tevi cu/fara vane
CRA	Panou de comanda de perete 230V - relee 5A/230V - selector 3 viteze On/Off - gestiune sistem 2 tevi cu 1 vana on-off 230 V / 230V wall thermostat. 3 speeds fan selector + Off/On selector + 2 pipes plant management with or without 230V on-off valves /
CRB	Panou de comanda de perete digital 230V/24V - relee 5A/230V. Selector 3 trepte de viteze si mod auto + gestiune sistem 2 sau 4 tevi cu 1 vana on/off, PWM, 3 puncte, rezistente / 230V/24V wall digital thermostat. 3 ways and auto selector + 2 or 4 pipes plant management with or without on-off valves, PWM, 3 points, electrical heaters
CBP	Panou de comanda de perete digital 230V/24V - relee 3A/230V. Ventilator on/off sau brushless, gestiune sistem 2 sau 4 tevi cu 1 vana on/off sau 0..10V alimentate 230V sau 24V / On-off or brushless fan, 2 or 4 pipes plant management with or without on-off valve or 0..10V with 230V or 24V alimentation.
CRI	Termostat electronic incastrat programabil 230 V - relee 3A/230V. Start/stop + selector 3 trepte de viteze + selector Vara/larna. Gestiune sistem 2 sau 4 tevi cu 1 vana on/off alimentata 230V. Necompatibil cu TMB / Programable 230V ducted electronic thermostat - Relay contacts 3A/230V. Start-Stop + 3-speeds fan selector + heat/cool selector. 2 pipes plant management with or without on-off valve with 230V alimentation. Not compatible with TMB
TMB	Termostato bimetallico di minima - Tset 32°C / Water low temperature thermostat - Tset 32° C / Thermostat basse température Thermostat - Tset 32°C / Termostato de minima - Tset 32° C / Termostot bimetal temp. min. - Tset 32°C
MOR	Morsettiera tipo "Mamut", sempre obbligatoria, compresa nei comandi a bordo macchina CVA-CVB-CVC-CVB-CVD. Negli altri casi deve essere ordinata come accessorio (montato a bordo macchina) / Mammoth type terminal board (included on the on board controller CVA-CVB-CVC-CVB-CVD) In other cases must be ordered as an accessory / Barrette de connexion type "Mamut" (Inclus sur le contrôleur de bord CVA-CVB-CVC-CVB-CVD) Dans d'autres cas doit être commandé comme accessoire / Klemmleiste "Mamut" (einschließlich an der Maschine CVA-CVB-CVC-CVB-CVD) In anderen Fällen muss als Zubehör bestellt werden / Tablero de barnes tipo "Mamut" (Incluida en el controlador de a bordo CVA-CVB-CVC-CVB-CVD) En otros casos se debe pedir como accesorio / Placă de borne de tip mamut este inclusă pe controlerul de bord CVA-CVB-CVB-CVB-CVB. In alte cazuri trebuie comandată ca accesoriu (se monteaza in fabrica).



3V2	Valvole a 3 vie per impianto 2 tubi con servocomando 230V / 3-way valve with actuator 230V for 2 pipes units / Vanne à 3 voies pour installation à 2 tuyaux avec servocommande 230V / 3-Wege-Ventile für 2 Rohre System mit Stellantrieb 230V / válvulas a 3 Vías para sistema de 2 tubos con servomando 230V / Vana cu 3 cai sistem 2 tevi cu servomotor 230V														
2V2	Valvole a 2 vie per impianto 2 tubi con servocomando 230V / 2-way valve with actuator 230V for 2 pipes units / Vanne à 2 voies pour installation à 2 tuyaux avec servocommande 230V / 2-Wege-Ventile für 2 Rohre System mit Stellantrieb 230V / válvulas a 2 vías para sistema de 2 tubos con servomando 230V / Vana cu 2 cai sistem 2 tevi cu servomotor 230V														
3V4	Valvole a 3 vie per impianto 4 tubi con servocomando 230V / 3-way valve with actuator 230V heating coil for 4 pipes units / Vanne à 3 voies pour installation à 4 tuyaux avec servocommande 230V / 3-Wege-Ventile für 4 Rohre System mit Stellantrieb 230V / válvulas a 3 vías para sistema de 4 tubos con servomando 230V / Vana cu 3 cai sistem 4 tevi cu servomotor 230V														
2V4	Valvole a 2 vie per impianto 4 tubi con servocomando 230V / 2-way valve with actuator 230V for 4 pipes units / Vanne à 2 voies pour installation à 4 tuyaux avec servocommande 230V / 2-Wege-Ventile für 4 Rohre System mit Stellantrieb 230V / válvulas a 2 vías para sistema de 4 tubos con servomando 230V / Vana cu 2 cai sistem 4 tevi cu servomotor 230V														
P1	Pannello per versione VIP/OIP / Panel made of pre-painted steel / Panneau pour version VIP/OIP / Panel für die Version VIP/OIP / Panel por versión VIP/OIP Panou decorativ pentru modelele VIP / OIP														
P2	Pannello per versione VIP/OIP con sportello comandi / Panel made of pre-painted steel with controll panel doors / Panneau pour version VIP/OIP avec tableau de commandes / Panel für die Version VIP/OIP mit Türsteuerungen / Panel por versión VIP/OIP con puerta comandos / Panou decorativ realizat din oțel pre-vopsit cu ușa pentru panoul de control														
FTI	Falso telaio incasso zincato per versioni VIP e OIP / False frame made of galvanizes steel for versions VIP and OIP / Faux châssis encastrable galvanisé pour version VIP e OIP / Rahmen Einbauleuchte verzinkt Version VIP und OIP / bastidor galvanizado empotrable para versiones VIP y OIP / Rama falsă din oțel zincat pentru versiunile VIP și VIP														
PMI	Plenum 90° mandata per versione VIP e OIP / Air supply plenum with spigots for versions VIP and OIP / Plénum 90° décharge pour version VIP et OIP / Plenum 90° Entlastung Version VIP und OIP / plenum 90° para versiones VIP y OIP / Plenum aspiratie 90° pentru gama VIP si OIP														
PCPF	Pannello in chiusura posteriore basso in lamiera preverniciata / Central closing back panel / Panneau avec fermeture postérieure basse en tôle prépeint / Schließung Panel niedrig hinten in lackiertem Stahlblech / panel de cierre bajo detrás en chapa prepintada / Panou decorativ posterior														
PCPB	Pannello in chiusura posteriore medio in lamiera preverniciata / Central closing back panel / Panneau avec fermeture postérieure moyenne en tôle prépeinte / Schließung Panel mittel hinten in lackiertem Stahlblech / panel de cierre medio detrás en chapa prepintada / Panou decorativ posterior														
PCB	Pannello in chiusura inferiore senza griglia in lamiera preverniciata / Bottom closing panel without grill / Panneau avec fermeture inférieure sans grille en tôle prépeinte / Schließung Panel unter in lackiertem Stahlblech / panel de cierre inferior sin rejilla en chapa prepintada / Panou decorativ inferior fara grila														
PM	Plenum con attacchi circolari mandata / Air supply plenum with spigots / Plénum de raccords à section circulaires de décharge / Plenum mit Rundschreiben Anschlüsse Entladung / plenum con conexiones circulares de descarga / Plenum refulare cu racorduri circulare														
PA	Plenum con attacchi circolari aspirazione / Air intake plenum with spigots / Plénum de raccords à section circulaire d'aspiration / Plenum mit Rundschreiben Anschlüsse Ansaugen / Plenum con conexiones circulares de succión / Plenum aspiratie cu racorduri circulare Plenum cu racorduri circulare - Plenum with spigots (PA, PM)														
	<table border="1"> <thead> <tr> <th>VE</th> <th>13/23</th> <th>33/43</th> <th>53/63</th> <th>73/83</th> <th>93P/103P</th> <th>113P/123P</th> </tr> </thead> <tbody> <tr> <td>Attacchi circolari - Racorduri (N° x Ø 200/180/160 mm)</td> <td>1 x Ø</td> <td>2 x Ø</td> <td>2 x Ø</td> <td>3 x Ø</td> <td>4 x Ø</td> <td>4 x Ø</td> </tr> </tbody> </table>	VE	13/23	33/43	53/63	73/83	93P/103P	113P/123P	Attacchi circolari - Racorduri (N° x Ø 200/180/160 mm)	1 x Ø	2 x Ø	2 x Ø	3 x Ø	4 x Ø	4 x Ø
VE	13/23	33/43	53/63	73/83	93P/103P	113P/123P									
Attacchi circolari - Racorduri (N° x Ø 200/180/160 mm)	1 x Ø	2 x Ø	2 x Ø	3 x Ø	4 x Ø	4 x Ø									
RA	Resistenza elettrica 230 V (0,7 Kw - 2 kW) / Electrical heater 230V (0,7 Kw - 2 Kw) / Résistance électrique 230 V (0,7kW - 2 kW) / elektrischer Widerstand 230 V (0,7kW - 2kW) / resistencia eléctrica 230 V (0,7 Kw - 2 kW) / Rezistentă electrică 230 V (0,7 - 2 kW)														
RB	Resistenza elettrica 230 V (1Kw - 3Kw) / Electrical heater 230V (1Kw - 3Kw) / Résistance électrique 230 V (1Kw - 3Kw) / elektrischer Widerstand 230 V (1Kw - 3Kw) / resistencia eléctrica 230 V (1Kw - 3Kw) / Rezistentă electrică 230 V (1 - 3 kW)														



<p>TEL</p>	<p>Scheda madre+Sonda aria+Sonda acqua+Ricevitore I.R.+Telecomando (gestione 2/4 tubi, con/ senza valvole). Ventilatore 7A-230Vac. Valvole: 2A-230Vac.</p> <p>Placa principala + senzor aer + senzor apa + receptor infrarosu + telecomanda infrarosu (control sistem 2 sau 4 tevi, cu sau fara vane). Ventilator 7A-230Vac. Vane: 2A-230Vac.</p>
<p>BMS-U1-V</p>	<p>Scheda principale con comunicazione integrata</p> <p>Placa principala cu comunicare integrata pentru sistem BMS</p>
<p>SND-A2</p>	<p>Sonda temperatura aria (obbligatoria per ogni scheda orincipale BMS)</p> <p>Senzor temperatura aer (obligatoriu pentru fiecare placa BMS)</p>
<p>SND-W2</p>	<p>Senzor de temperatura apa VARA/IARNA</p> <p>SUMMER/WINTER Water temperature sensor</p>
<p>SND-W3</p>	<p>Senzor de temperatura min apa</p> <p>Minimum water temperature sensor</p>
<p>CD6</p>	<p>Panou de comanda de perete digital</p> <p>Wall mounted external digital control</p>