

CAD-Nr.:

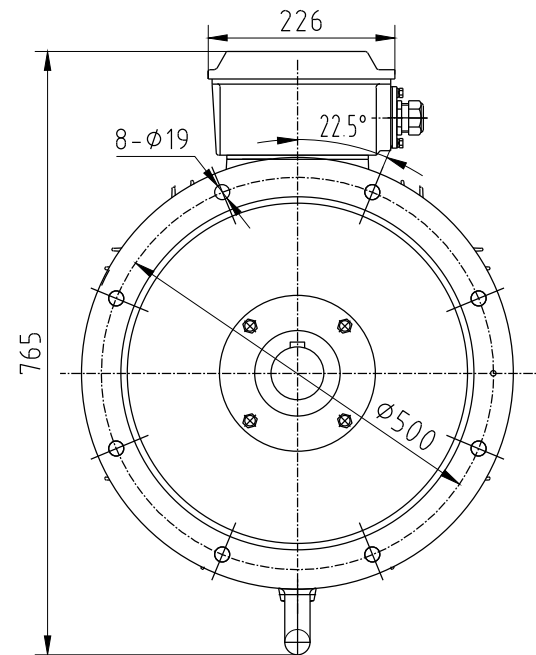
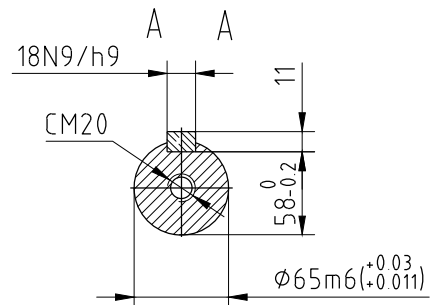
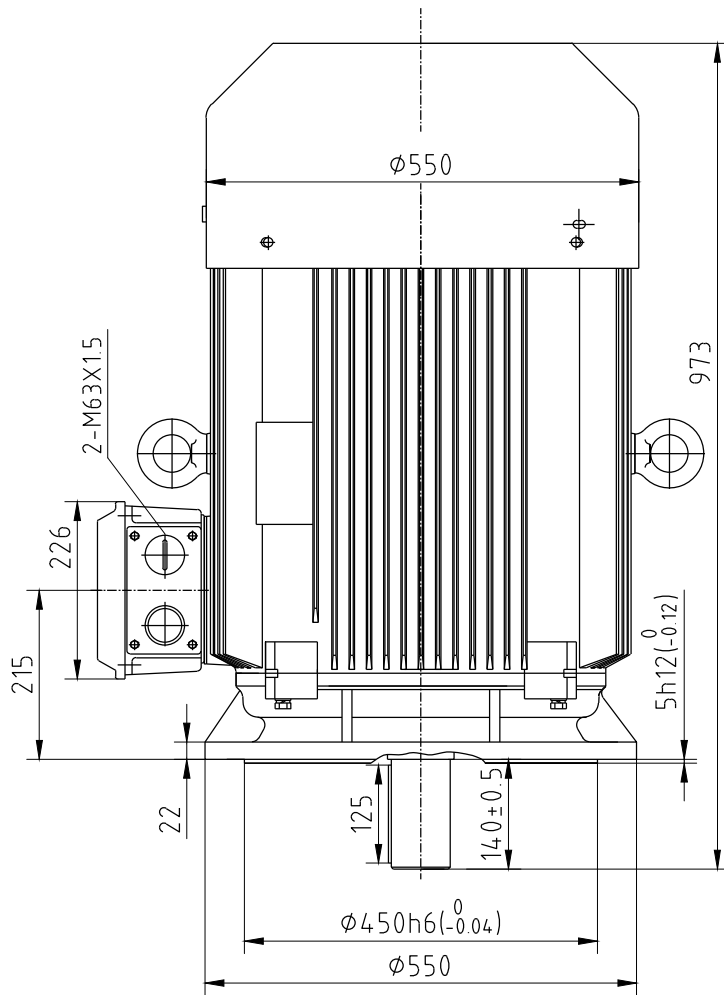

Kennwort:		Stand	Type	MEBK 280S-02-190 V1	
Datum		Name		Maßzeichnung	
Bearbeitet	02.04.2013	Zipperling		Drehstrommotor	
Geprüft	02.04.2013	M.Menzel			
Geändert					
					Blatt 1
(Urspr.)			(Ers. f.)		(Ers. d.)

Blatt  
1  
1 Bl