



# FinnpiPette® Novus

## Single Channel & Multichannel

### Instructions for Use

# CONTENT

<b>PRODUCT DESCRIPTION</b> .....	<b>4</b>
Raw materials .....	5
Description of tips .....	5
<b>PACKAGE</b> .....	<b>5</b>
<b>GETTING STARTED</b> .....	<b>5</b>
Power supply .....	5
Power Requirements .....	5
Power plug adapters .....	5
Installing the battery .....	6
Charging the battery .....	7
Adjusting the trigger position .....	7
Tip ejection .....	7
Shelf hanger .....	7
<b>PIPETTE OPERATION</b> .....	<b>9</b>
Choosing pipetting functions and speed .....	9
The Menu Map .....	10
Pipette (Forward technique) .....	10
Rpipet (Reverse & Repetitive) .....	11
Reverse technique .....	11
Repetitive technique .....	11
Stepper (multi dispensing) .....	12
Dilute .....	12
Program .....	13
Additional functions in program mode .....	13
Mix + Pipette .....	13
Pipette + Count .....	13
Seq stepper .....	14
Mix + Dilute .....	14
Manual .....	15
Seq + Aspirate .....	15
Options .....	16
Calibrate .....	16
Service .....	16
Language .....	16
Name .....	16
Power .....	16
Buzzer .....	16
Version .....	16
Backlight .....	16

<b>CALIBRATION</b> .....	<b>17</b>
Device requirements and test conditions .....	17
Calibration Counter .....	17
Checking the calibration .....	17
Procedure .....	17
Adjustment .....	18
Two point calibration .....	18
One point calibration .....	19
Formulas for calculating results .....	19
Conversion of mass to volume .....	19
Inaccuracy (systematic error) .....	20
Imprecision (random error) .....	20
<b>MAINTENANCE</b> .....	<b>21</b>
Daily checking .....	21
Short-term Service Single Channel pipettes .....	21
Long-term service Single Channel pipettes .....	22
Short-term Service Multichannel pipettes .....	24
Long-term service Multichannel pipettes .....	25
Service Instructions for Multichannel Pipette Tip Cones .....	26
Replacing the battery .....	26
Opening the Version 1 battery lid .....	26
Opening the Version 2 battery lid .....	26
Sterilization Single Channel pipettes .....	27
Sterilization Multichannel pipettes .....	27
<b>TROUBLE SHOOTING</b> .....	<b>28</b>
<b>TECHNICAL DATA</b> .....	<b>30</b>
<b>SPARE PARTS SCP</b> .....	<b>31-33</b>
<b>SPARE PARTS MCP</b> .....	<b>34-37</b>



WEEE (Waste Electrical and Electronic Equipment) symbol indicates that this product should not be disposed of in unsorted municipal waste. Follow local municipal waste ordinances for proper disposal provisions to reduce the environmental impact of WEEE.



This instrument meets European requirement WEEE Directive 2012/19/EU.

Product specifications are subject to change without prior notice. Finnpiquette® and Finntip® are registered trademarks of Thermo Scientific.

See the latest version at [www.thermofisher.com](http://www.thermofisher.com)

# PRODUCT DESCRIPTION

The different models of Finnpiquette Novus pipettes cover a volume range from 1  $\mu$ l to 10 ml.

<b>Order No.</b>	<b>Volume Range</b>		<b>Finntip</b>
46200000	1 $\mu$ l	to 10 $\mu$ l	<b>Flex 10</b> , 10, 20, 50
46200100	1 $\mu$ l	to 10 $\mu$ l	<b>Flex 200</b> , 250 Univ., 200 Ext, 300
46200200	5 $\mu$ l	to 50 $\mu$ l	<b>50</b>
46200300	5 $\mu$ l	to 50 $\mu$ l	<b>Flex 200</b> , 250 Univ., 200 Ext, 300
46200400	10 $\mu$ l	to 100 $\mu$ l	<b>Flex 200</b> , 250 Univ., 200 Ext, 300
46200500	30 $\mu$ l	to 300 $\mu$ l	<b>Flex 300</b> , 300
46200600	100 $\mu$ l	to 1000 $\mu$ l	<b>Flex 1000</b> , 1000, 1000 Ext
46200700	0,5 ml	to 5 ml	<b>5 ml</b>
46200800	1 ml	to 10 ml	<b>10 ml</b> , Flex 10 ml Ext

The different models of Finnpiquette Novus pipettes cover a volume range from 1  $\mu$ l to 1200  $\mu$ l.

<b>Order No.</b>	<b>Channel</b>	<b>Volume Range</b>		<b>Finntip</b>
46300000	8	1 $\mu$ l	to 10 $\mu$ l	<b>Flex 10</b> , 10, 20, 50
46300100	12	1 $\mu$ l	to 10 $\mu$ l	<b>Flex 10</b> , 10, 20, 50
46300200	8	5 $\mu$ l	to 50 $\mu$ l	<b>Flex 200</b> , 250 Univ., 200 Ext
46300300	12	5 $\mu$ l	to 50 $\mu$ l	<b>Flex 200</b> , 250 Univ., 200 Ext
46300400	8	30 $\mu$ l	to 300 $\mu$ l	<b>Flex 300</b> , 300
46300500	12	30 $\mu$ l	to 300 $\mu$ l	<b>Flex 300</b> , 300
46300700	16	5 $\mu$ l	to 50 $\mu$ l	<b>50</b>
46300800	8	100 $\mu$ l	to 1200 $\mu$ l	<b>Flex 1200</b>

The Finnpiquette Novus is an electronically assisted pipette for a wide range of liquid handling operations. Thanks to the electronic motor and electronic control, pipetting is easy and comfortable, yet still fast and accurate. It operates on the air displacement principle (i.e. an air interface) and uses detachable, disposable tips, which are easy to remove with a soft touch tip ejector.

The adjustable, index finger operated pipetting trigger uses natural hand movement, increasing comfort and reducing the risk of repetitive stress injuries. The Finnpiquette Novus provides many functions which are very practical for daily use in laboratory work, such as forward-, reverse- and repetitive pipetting, stepper and diluting modes.

The guiding and easy user-interface is very fast to learn. The adjusted delivery volume is clearly indicated in the LCD display on top of the handle. The long lasting Lithium-Ion -battery is always charged with rapid charge technique. If needed, the battery can be charged over the lunch hour.

## Raw materials

The Finnpiquette Novus is made of mechanically durable and chemically resistant materials. The tip cone modules can be repeatedly autoclaved at 121°C.



**Note** The 1200 µl module is NOT autoclavable.

## Description of tips

Finntips are recommended for use with the Finnpiquette Novus. They are made of natural colour polypropylene, generally regarded as the only contamination free material suitable for tips. Finntips are also autoclavable (121°C).

## PACKAGE

The complete Finnpiquette Novus package contains:

1. Finnpiquette Novus
2. Charger
3. Piston removal tool
4. Instructions for use
5. Calibration Certificate / Warranty Certificate

## GETTING STARTED

Remove the content from the package and verify that all items listed above are included. Inspect for possible shipping damage. Make sure that the pipette is desired volume range and that the voltage of the charger is correct.



**Note** If the device is not used according to manufacturers instructions the protection provided by the device cannot be guaranteed.

## Power supply

### Power Requirements

- INPUT: 100-240V~50/60Hz, 300 mA
- OUTPUT: 5,0V --- 0,5 A max

### Power plug adapters:

1. Australia
2. Europe
3. United Kingdom
4. USA / Japan
5. Power supply unit



Insert the country specific power plug adapter into the power supply unit.



**Note** The charger's plug must be inserted in a socket that is easy to reach and from which it can be easily unplugged in case of emergency.



**Warning** Use of incorrect power supply units may result in fatal injuries and damage to the device.

Use of incorrect power supply units may result in overheating, burning, melting, short-circuiting of the Thermo Scientific FinnpiPETTE Novus pipette or similar damage.

Only use the supplied power supply unit for charging the pipette. You can recognize the correct power supply by the Thermo Scientific logo and the pipette name on the power supply unit.

Do not charge the pipette in a hot location (>40°C)



## Installing the battery



**Note** If the pipette is supplied with the battery attached the below installation is not needed.

- Check, that the battery wires are as shown in the picture.



**Note** Do not remove the tape that is holding the wires

- Slide in the battery (label side visible)
- Connect the battery connector.
- Ensure that the wires are flat, not twisted
- Attach the battery lid as shown in the picture

## Charging the battery



**Warning** Use only the original Finnpiquette Novus charger and battery pack.

The pipette battery may be empty when delivered and must be charged before initial use. Connect the lead of charger to the socket on the back of pipette. Then connect the charger to an AC wall socket. If the battery is completely empty, it may take a few minutes before the pipette will turn on. You can use the pipette while the charger is connected. The charging time is typically less than one hour. An indicator in the LCD display shows the charge level of the battery.

When the indicator shows empty battery, pipetting is no more possible, and the pipette has to be charged again. To extend battery life cycle, it's recommended to charge the pipette every two months even if/ even though the pipette is not used daily. A typical Finnpiquette Novus battery lasts for around 500 charging cycles. Please note that an old battery can cause the pipette to malfunction. We recommend that you change the battery every 3 years.

## Adjusting the trigger position

The index finger operated trigger, which activates the piston movement, can be adjusted by rotating it 60 degrees to both directions of the center position. Usually right handed operators turn it left (counter clockwise) to get the best possible position for the thumb to eject the tip. **See picture on page 9.**

## Tip ejection

To help eliminate the risk of contamination, each pipette is fitted with a tip ejector system.

The tip ejector system consists of a soft-touch tip ejector and specially designed gearing mechanism. To release the tips, point the pipette at suitable waste receptacle and press the tip ejector with your thumb.

## Shelf hanger

You can attach the pipette shelf hanger on a counter, pipette stand or anywhere where you want to hang your pipette. Clean the area where you plan to attach the shelf hanger. Apply two stickers to the underside of the shelf hanger. Press the shelf hanger firmly into place — on a shelf, countertop or pipette stand. To use, hang the grippy finger rest on the shelf hanger.

## Safety Precautions



**Warning** Novus pipette contains a Li-Ion battery and a potential malfunction of the battery (short circuit, mechanical damage, overheating etc) may cause explosion.



**Warning** Incorrect handling of the battery or pipette may cause personal injury. Do not drop the battery. Do not expose battery to any kind of mechanical stress or extreme temperatures: above 60 °C (45 °C when charging) or under 0 C°.



**Warning** Do not immerse the unit in liquid and do not clean the upper part of the pipette by spraying. Fluid seepage can damage internal components and may cause a safety risk.



**Warning** Follow the Novus pipette instructions presented in the user manual in part, Technical Data. If the instructions are not followed it may cause a safety risk.

# PIPETTE OPERATION

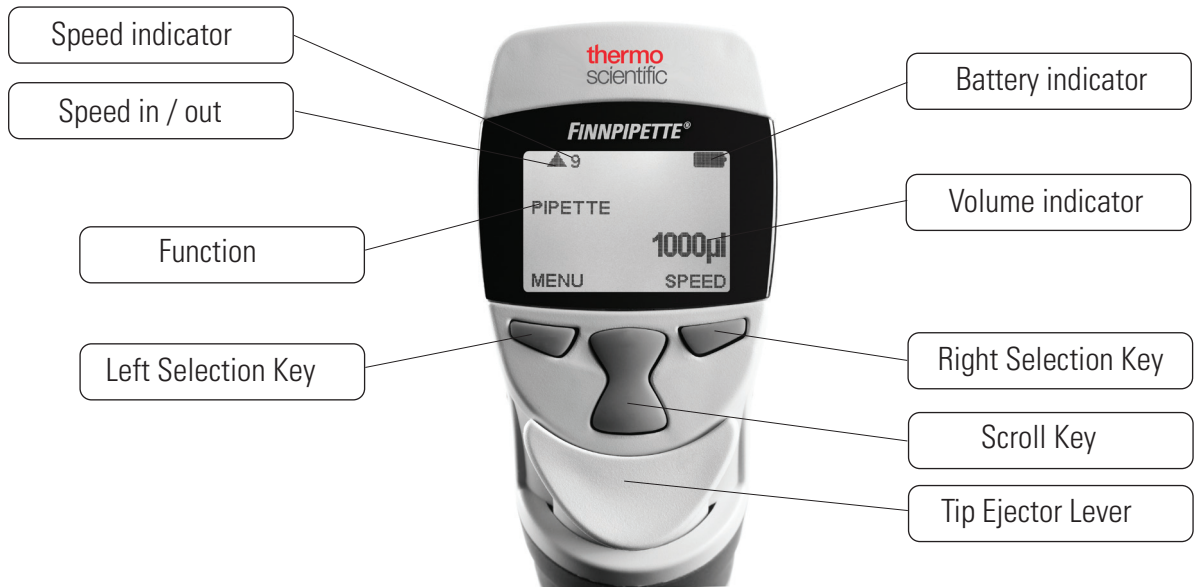

## Choosing pipetting functions and speed

To choose the pipetting function press Menu (left selection key). Scroll the function list and select the desired function with OK (right selection key). In most cases the volume can be selected simply by pressing the scroll key up or down. Accept the volume with OK. In some cases the initial piston position has to be changed and a text PRESS TRIGGER appears on display. Press the trigger to move the piston to the new initial position.

Pipetting speeds can be selected with the right selection key whenever the text SPEED is displayed. Press SPEED and the speed in starts to blink. Select the speed with scroll key and accept with OK. Now the speed out starts to blink. Select the speed with scroll key and accept with OK.



# The Menu Map

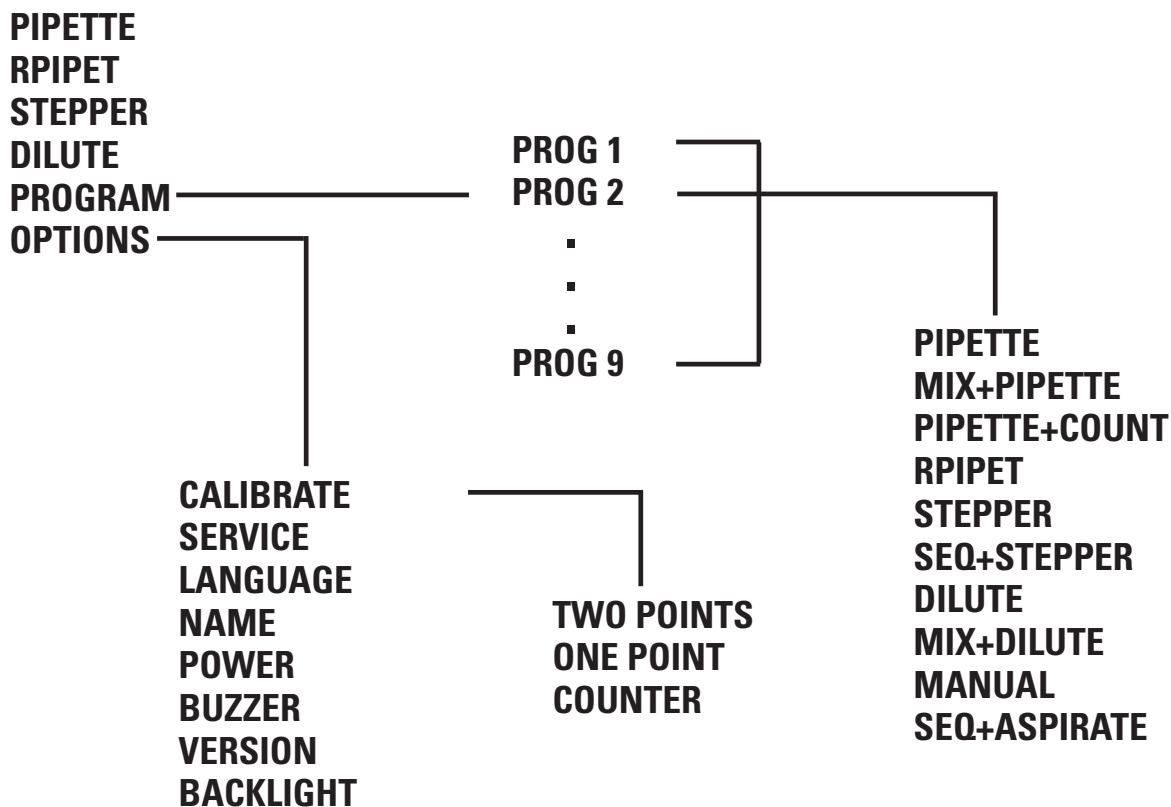

## Pipette (Forward technique)

Choose the PIPETTE function as described above.

Select the pipetting volume simply by pressing the scroll key up or down.

Accept the volume with OK. Optionally press SPEED and the speed in starts to blink. Select the speed with scroll key and accept with OK. Select the speed out with scroll key and accept with OK.

1. Dip the tip under the surface of the liquid in the reservoir and press the trigger. The liquid is drawn in to the tip.
2. Wait until the liquid is not moving in the tip and withdraw the tip from the liquid touching it against the edge of the reservoir to remove excess liquid.
3. To deliver the liquid press the trigger and hold it down. The blow-out is also included to empty the tip.
4. Release the trigger to return to the ready position.

If necessary, change the tip and continue pipetting.

## Rpipet (Reverse & Repetitive)

With RPIPET function both reverse and repetitive techniques are possible. Choose the RPIPET function as described above.

Select the pipetting volume simply by pressing the scroll key up or down. Accept the volume with OK. Press SPEED and the speed in starts to blink. Select the speed with scroll key and accept with OK. Select the speed out with scroll key and accept with OK.

## Reverse technique

The reverse technique is suitable for dispensing liquids that have a high viscosity or a tendency to foam easily. The technique is also recommended for dispensing very small volumes.

Fill a clean reagent reservoir with the liquid to be dispensed.

1. Dip the tip under the surface of the liquid in the reservoir and press the trigger. This action will fill the tip.
2. Withdraw the tip from the liquid touching it against the edge of the reservoir to remove excess liquid.
3. Deliver the preset volume by **shortly pressing the trigger**. Some liquid will remain in the tip and this should not be included in the delivery. A text BLOWOUT is displayed.
4. To empty the tip, press trigger again.

If necessary, change the tip and continue pipetting.

## Repetitive technique

The repetitive technique offers a rapid and simple procedure for repeated delivery of the same volume. Fill a clean reagent reservoir with the liquid to be dispensed.

1. Dip the tip under the surface of the liquid in the reservoir and press the trigger. This action will fill the tip.
2. Withdraw the tip from the liquid touching it against the edge of the reservoir to remove excess liquid.
3. Deliver the preset volume by **pressing and holding the trigger down**. Some liquid will remain in the tip and this should not be included in the delivery.
4. Dip the tip again to reagent reservoir and release the trigger. This action will fill the tip again.
5. Continue pipetting by repeating steps 3 and 4.
6. To empty the tip completely, dispense by **shortly** pressing the trigger. Some liquid will remain in the tip and this should not be included in the delivery. A text BLOWOUT is displayed.
7. To empty the tip completely, press trigger again.

If necessary, change the tip and continue pipetting.

## Stepper (multi dispensing)

With STEPPER function repeated dispensing of selected volume is possible. Choose the STEPPER function as described above.

Select the pipetting volume simply by pressing the scroll key up or down. The display shows always the maximum number of steps during volume selection. Accept the volume with OK. Next choose the number of steps with scroll key and accept with OK.

Optionally select the speed. Press SPEED and the speed in starts to blink. Select the speed with scroll key and accept with OK. Select the speed out with scroll key and accept with OK.

Fill a clean reagent reservoir with the liquid to be dispensed.

1. Dip the tip under the surface of the liquid in the reservoir and press the trigger. This action will fill the tip.
2. Withdraw the tip from the liquid touching it against the edge of the reservoir to remove excess liquid.
3. Deliver the preset volume by pressing the trigger. The display shows the number of steps left.
4. Continue dispensing by repeating step 3. After last step a text BLOWOUT is displayed.
5. To empty the tip completely, press trigger and hold it down.
6. Release the trigger.

If necessary, change the tip and continue pipetting.



**Note** The pipette can be emptied at any time by pressing CANCEL (left selection key)

## Dilute

With DILUTE function dispensing of two selected volume is possible. Choose the DILUTE function as described above. First volume (VOL 1) is shown on display.

Select the pipetting first volume simply by pressing the scroll key up or down. Accept the volume with OK. Next select the second volume (VOL 2) with scroll key and accept with OK.

Optionally select the speed. Press SPEED and the speed in starts to blink. Select the speed with scroll key and accept with OK. Select the speed out with scroll key and accept with OK.

1. Dip the tip under the surface of the first liquid in the reservoir and press the trigger. The first volume is drawn in to the tip. A text AIR appears on display.
2. Withdraw the tip from the liquid touching it against the edge of the reservoir to remove excess liquid. Press trigger again to aspirate air buffer.
3. Dip the tip under the surface of the second liquid and press the trigger. The second volume is drawn in to the tip.
4. Withdraw the tip from the liquid.
5. To deliver the both volumes, press the trigger and hold it down. The blow-out is also included to empty the tip.
6. Release the trigger to return to the ready position.

If necessary, change the tip and continue pipetting.

## Program

Programs are stored settings, that can be edited, stored and retrieved. Additional functions as mixing, counter etc. are available in program mode.

To retrieve a program, choose PROGRAM from menu as described above. The display shows the first program (PROG1). Select the desired program with scroll key and accept with OK.

If you want to change the settings, press EDIT. Select the function with scroll key and accept with OK. Note that there are additional functions available compared to main menu. After selecting the function, set the volumes, speeds etc. as described in the function instruction above.

When working with programs, the scroll key selects the program and it is a very fast way to switch between different settings.

## Additional functions in program mode

### Mix + Pipette

This function adds automatic mixing after normal pipetting. First select the desired volume with scroll key and accept with OK. Then select pipetting speeds accordingly. After dispensing the volume a text MIX appears on display. By pressing trigger the pipette starts to pipette ca. 70 % of the selected volume several times as long as the trigger is held pressed. After releasing the trigger the pipettes stops after next dispensing and a text BLOWOUT appears to display. A normal blowout function is done by pressing the trigger and pipette is again ready for next pipetting.

### Pipette + Count

This function adds automatic count number to pipetting. First select the desired volume with scroll key and accept with OK. Then select pipetting speeds accordingly. Next choose the max. number of pipettings, the default value is 999. After the max. number of pipettings is reached, the counter returns to zero. The counter can be reset at any time to zero by pressing SCROLL DOWN ; OK ; SCROLL UP ; OK.

## Seq stepper

The sequential stepper mode enables serial dispensing of different volumes (in normal stepper mode only fixed volume). First choose the amount of dispensings (max. 20) with SCROLLKEY and accept with OK. Vol 1 appears to display and highest possible volume is flashing. Select the first volume with SCROLLKEY and accept with OK. Now Vol 2 appears to display and highest possible volume left is flashing. Select the second volume with SCROLLKEY and accept with OK. After selecting the last volume the total volume is shown on display and speed in is flashing. Select the pipetting speeds and the pipette is ready for pipetting.

1. Dip the tip under the surface of the liquid in the reservoir and press the trigger. This action will fill the tip and the first volume appears on the display.
2. Withdraw the tip from the liquid touching it against the edge of the reservoir to remove excess liquid.
3. Deliver the first volume by pressing the trigger. The display shows the next volume.
4. Continue dispensing by repeating step 3. After last step a text BLOWOUT is displayed.
5. To empty the tip completely, press trigger.
6. If necessary, change the tip and continue pipetting.



**Note** The pipette can be emptied at any time by pressing CANCEL (left selection key)

## Mix + Dilute

Select the first pipetting volume by pressing the scroll key up or down. Accept the volume with OK. Next select the second volume (VOL 2) with scroll key and accept with OK. Then select the pipetting speeds.

1. Dip the tip under the surface of the first liquid in the reservoir and press the trigger. The first volume is drawn in to the tip. A text AIR appears on display.
2. Withdraw the tip from the liquid touching it against the edge of the reservoir to remove excess liquid. Press trigger again to aspirate air buffer.
3. Dip the tip under the surface of the second liquid and press the trigger. The second volume is drawn in to the tip.
4. Withdraw the tip from the liquid.
5. To deliver the both volumes, press the trigger. A text MIX appears on the display.
6. By pressing trigger the pipette starts to pipette ca. 70 % of the total volume several times as long as the trigger is held pressed.
7. After releasing the trigger the pipette stops after next dispensing and a text BLOWOUT appears to display.
8. Withdraw the tip from the liquid and press the trigger and hold it down to empty the tip.
9. Release the trigger to return to the ready position.
10. If necessary, change the tip and continue pipetting.

## Manual

With manual mode it is possible to measure volumes. In manual mode only slower speeds are available to ensure a quick stop. First select a limit for total volume, the default is the max. volume. Then select the pipetting speeds and zero volume appears to the display.

1. Dip the tip under the surface of the liquid in the reservoir and press the trigger. The liquid is drawn in to the tip and the actual volume is shown on the display.
2. The pipetting direction can be changed with IN/OUT key (Left selection key).
3. To deliver the liquid selected the down direction and press the trigger.
4. To deliver out the rest of the liquid, press the trigger and hold it down.
5. If necessary, change the tip and continue pipetting.



**Note** The volume display can be reset to zero at any time by pressing RESET with right selection key.

## Seq + Aspirate

The sequential aspirate mode enables serial aspirating of different volumes. First choose the number of volumes (max. 20) with SCROLLKEY and accept with OK. Vol 1 appears to display and highest possible volume is flashing. Select the first volume with SCROLLKEY and accept with OK. Now Vol 2 appears to display and highest possible volume left is flashing. Select the second volume with SCROLLKEY and accept with OK. After selecting the last volume the total volume is shown on display and speed in is flashing for selecting the pipetting speeds. After selecting the speeds the first volume is shown on the display and the pipette is ready for pipetting.

1. Dip the tip under the surface of the liquid and press the trigger. This action will take up first volume and the next volume appears on the display.
2. Withdraw the tip from the liquid touching it against the edge of the reservoir to remove excess liquid.
3. Dip the tip under the surface of the next liquid and press the trigger. This action will take up current volume and the next volume appears on the display.
4. Repeat steps 2. and 3. until last volume is drawn in to the tip. The total volume is shown on the display.
5. Deliver the total volume by pressing the trigger and hold it down. The blowout volume is included in the delivered volume.
6. Release the trigger to return to the ready position.
7. If necessary, change the tip and continue pipetting.



**Note** The pipette can be emptied at any time by pressing CANCEL (left selection key)

## **Options**

### **Calibrate**

Calibration mode. See chapter calibration.

### **Service**

The piston can be disconnected and reconnected in Service mode. For details see chapter Maintenance.

### **Language**

#### **Name**

This function enables user to set a name to the pipette. The name is always shown on the display when the pipette is in sleep mode. To change the default name choose NAME from the menu and press edit. The first digit starts to flash. Change the digit with SCROLLKEY and accept and move to next digit with OK. When the last digit is accepted the name is changed.

#### **Power**

With this function the power can be turned off. Pressing any key turns on the power.

#### **Buzzer**

The buzzer can be turned on and off with this function.

#### **Version**

The software version is displayed.

#### **Backlight**

With this function the backlight can be turned on/off.

# CALIBRATION

All Finnpiettes are factory calibrated and adjusted to give the volumes as specified with distilled or deionized water. Normally, the pipettes do not need adjustment, but they are constructed to permit recalibration and adjustment for liquids of different temperature and viscosity.

## Device requirements and test conditions

An analytical balance must be used. The scale graduation value of the balance should be chosen according to the selected test volume of the pipette:

Volume range	readable graduation	Precision repeatability(s) and linearity	Uncertainty of measurement
under 10 µl	0.00 1mg	0.001mg	0.002µl
10-100 µl	0.01 mg	0.02mg	0.02µl
above 100 µl	0.1 mg	0.2mg	0.2µl

If the uncertainty of measurement of the balance is known, this may be used instead of the repeatability and linearity.

Test liquid: Water, distilled or deionized, "grade 3" water conforming ISO 3696. Tests are done in a draft-free room at a constant ( $\pm 0.5^{\circ}\text{C}$ ) temperature of water, pipette and air between  $15^{\circ}\text{C}$  to  $30^{\circ}\text{C}$ .

The relative humidity must be above 50%. Especially with volumes under  $50\mu\text{l}$  the air humidity should be as high as possible to reduce the effect of evaporation loss. Special accessories, such as the evaporation trap, are recommended.

## Calibration Counter

By selecting MENU -> OPTIONS -> CALIBRATE -> COUNTER the number of pipettings since last calibration is shown on the display. The counter is reset to zero when calibration is performed.

## Checking the calibration

The pipette is checked with the maximum volume (nominal volume) and with the minimum volume. A new tip is first pre-wetted 3-5 times and a series of ten pipettings are done with both volumes. A pipette is always adjusted for delivery (Ex) of the selected volume. Measuring volumes taken from balance is not allowed.

### Procedure:

1. Do 10 pipettings with the minimum volume.
2. Do 10 pipettings with the maximum volume.
3. Calculate the inaccuracy (A) and imprecision (cv) of both series.
4. Compare the results to the limits in the Table 1.

If the calculated results are within the selected limits, the adjustment of the pipette is correct.

TABLE1: Maximum permissible errors according ISO 8655

<b>Range</b>	<b>Volume <math>\mu</math>l</b>	<b>Inaccuracy</b>		<b>Imprecision</b>	
		<b><math>\mu</math>l</b>	<b>%</b>	<b>s.d. <math>\mu</math>l</b>	<b>cv%</b>
1-10 $\mu$ l	10	$\pm 0.120$	$\pm 1.2$	0.080	0.8
	1	$\pm 0.120$	$\pm 12$	0.080	8.0
5-50 $\mu$ l	50	$\pm 0.50$	$\pm 1.0$	0.20	0.4
	5	$\pm 0.50$	$\pm 10$	0.20	4.0
10-100 $\mu$ l	100	$\pm 0.80$	$\pm 0.8$	0.30	0.3
	10	$\pm 0.80$	$\pm 8.0$	0.30	3.0
30-300 $\mu$ l	300	$\pm 4.0$	$\pm 1.3$	1.5	0.5
	30	$\pm 4.0$	$\pm 13$	1.5	5.0
100-1000 $\mu$ l	1000	$\pm 8.0$	$\pm 0.8$	3.0	0.3
	100	$\pm 8.0$	$\pm 8.0$	3.0	3.0
0,5-5 ml	5000	$\pm 40.0$	$\pm 0.8$	15.0	0.3
	500	$\pm 40.0$	$\pm 8.0$	15.0	3.0
1-10 ml	10000	$\pm 60.0$	$\pm 0.6$	30.0	0.3
	1000	$\pm 60.0$	$\pm 6.0$	30.0	3.0

<b>Range</b>	<b>Channel</b>	<b>Volume <math>\mu</math>l</b>	<b>Inaccuracy</b>		<b>Imprecision</b>	
			<b><math>\mu</math>l</b>	<b>%</b>	<b>s.d. <math>\mu</math>l</b>	<b>cv%</b>
1-10 $\mu$ l	8, 12	10	$\pm 0.24$	$\pm 2.4$	0.16	1.6
		1	$\pm 0.24$	$\pm 24$	0.16	16
5-50 $\mu$ l	8, 12, 16	50	$\pm 1.0$	$\pm 2.0$	0.4	0.8
		5	$\pm 1.0$	$\pm 20$	0.4	8.0
30-300 $\mu$ l	8, 12	300	$\pm 8.0$	$\pm 2.7$	3.0	1.0
		30	$\pm 8.0$	$\pm 26.7$	3.0	10.0
100-1200 $\mu$ l	8	1200	$\pm 32$	$\pm 2.7$	12	1.0
		100	$\pm 32$	$\pm 32$	12	12

## Adjustment Two point calibration

Normally the two-point calibration should be used.

1. Do the pipetting series with both max. and min. volumes.
2. Calculate the actual results.
3. Press MENU and select options with SCROLLKEY and accept with OK.
4. Select CALIBRATE and press OK.
5. Select two points and confirm with OK. The target max. and target min. volumes are shown on the display.
6. Press EDIT and change the actual max. volume with the SCROLLKEY and accept with OK.
7. Change the actual min. volume with the SCROLLKEY and accept with OK.
8. A text SAVE? appears on the display.
9. Accept with YES
10. The adjustment has been changed.

## One point calibration

The one point calibration can be used if a single specific volume must be calibrated. The calibration volume can be selected from the entire volume range. Note that the inaccuracy of other volumes changes also and the performance for other volumes cannot be assured.

1. Do the pipetting series with calibration volume.
2. Calculate the results.
3. Press MENU and select options with SCROLLKEY and accept with OK.
4. Select CALIBRATE and press OK.
5. Select one point and confirm with OK. The calibration volume is shown on the display.
6. Press EDIT and change the calibration volume with the SCROLLKEY and accept with OK.
7. Change the actual volume with the SCROLLKEY and accept with OK.
8. A text SAVE? appears on the display.
9. Accept with YES
10. The adjustment has been changed.

## Formulas for calculating results

### Conversion of mass to volume

$$V = (w + e) \times Z$$

V = volume (µl)  
w = weight (mg)  
e = evaporation loss (mg)  
Z = conversion factor for µl/mg conversion

Evaporation loss can be significant with low volumes. To determine mass loss, dispense water to the weighing vessel, note the reading and start a stopwatch. See how much the reading decreases during 30 seconds (e.g. 6mg = 0.2mg/s).

Compare this to the pipetting time from taring to reading. Typically pipetting time might be 10 seconds and the mass loss is 2 mg (10s x 0.2mg/s) in this example. If an evaporation trap or lid on the vessel is used the correction of evaporation is usually unnecessary.

The factor Z is for converting the weight of the water to volume at test temperature and pressure. A typical value is 1.0032µl/mg at 22°C and 95 kPa.

**See the conversion table on page 29.**

## Inaccuracy (systematic error)

Inaccuracy is the difference between the dispensed volume and the selected volume of a pipette.

$$\mathbf{A = \bar{V} - V_0}$$

A = inaccuracy  
 $\bar{V}$  = mean volume  
 $V_0$  = nominal volume

Inaccuracy can be expressed as a relative value:

$$\mathbf{A\% = 100\% \times A / V_0}$$

## Imprecision (random error)

Imprecision refers to the repeatability of the pipettings. It is expressed as standard deviation (s) or coefficient of variation (cv)

$$\mathbf{S = \sqrt{\frac{\sum_{i=1}^n (V_i - \bar{V})^2}{n - 1}}}$$

s = standards deviation  
 $\bar{V}$  = mean volume  
n = number of measurements

Standard deviation can be expressed as a relative value (CV)

$$\mathbf{CV = 100\% \times S / \bar{V}}$$

# MAINTENANCE

When the Finnpiquette Novus is not in use, make sure it is stored in an upright position. We recommend a Finnpiquette stand for this purpose.

**The part # refer to exploded views beginning at page 31.**

## Daily checking

The pipette should be checked at the beginning of each day for dust and dirt on the outside surfaces of the pipette. Particular attention should be paid to the tip cone. No other solvents except 70 % ethanol should be used to clean the pipette.

## Short-term Service Single channel pipettes

If the pipette is used daily it should be checked and lubricated every three months. The servicing procedure starts with choosing the Service-mode from the menu (Menu -> Options -> Service).

### Pipettes up to 1000 µl

1. Remove the lower tip ejector sleeve 13 by pulling it out (snap fitting).
2. Push down the ejector button and take the upper ejector top 11 between fingers.
3. Release the ejector button to up position, but hold the tip ejector top 11 in down position with the fingers.
4. Remove the tip cone by pulling it out (snap fitting).
5. Press and hold the trigger down to drive out the piston.
6. Insert the special piston removal tool and pull out the piston 14. The number 2 end is for 300µl and 1000µl pistons, the number 1 end for all the smaller volumes. **See picture.** Release the trigger.
7. Check the tip cone for foreign particles.
8. Grease the cleaned parts with the lubricant that comes with the pipette.
9. Reassemble the pipette components.
10. Insert carefully the piston to the tip cone.
11. Push the tip cone back to the handle while holding the ejector top 11 down, until you hear a "click".
12. Press trigger to reconnect the piston to drive mechanism.
13. Press READY to return from service mode.

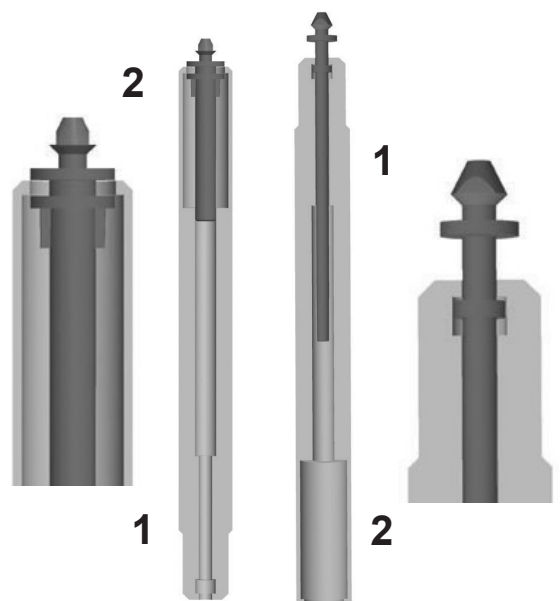

## 5 ml and 10 ml pipettes

1. Pull down the lower tip ejector sleeve.
2. Note that the tip ejector button is in fully up position.
3. Remove the tip cone by pulling it out (snap fitting).
4. Remove the ejector sleeve by pulling it to two parts (snap fitting).
5. Push the snap joints to release and remove the cylinder 14.
6. Push forward and clean the piston with a dry napless cloth.
7. Check the tip cone for foreign particles.
8. Grease the cleaned parts with the lubricant that comes with the pipette.
9. Reassemble the pipette components in reverse order.
10. Push the tip cone back to the handle while holding the ejector top 11 down, until you hear a "click"
11. Press trigger to reconnect the piston to drive mechanism.
12. Press READY to return from service mode.

## Long-term service Single channel pipettes

If the pipette is used daily it should be serviced every six months. The servicing procedure starts with the disassembly of the pipette.

### Pipettes up to 1000 $\mu$ l

1. Remove the lower tip ejector sleeve 13 by pulling it out (snap fitting).
2. Push down the ejector button and take the upper ejector top 11 between fingers.
3. Release the ejector button to up position, but hold the tip ejector top 11 in down position with the fingers.
4. Remove the tip cone by pulling it out (snap fitting).
5. Press and hold the trigger down to drive out the piston.
6. Insert the special piston removal tool and pull out the piston 14. The number 2 end is for 300 $\mu$ l and 1000 $\mu$ l pistons, the number 1 end for all the smaller volumes. **See picture on page 21.** Release the trigger.
7. Remove spring hatch 25 by pressing it down and in the same time turning 90 degrees. Take out the spring 16.
8. Remove the rest of the parts from tip cone with the piston.
9. Clean the parts with a dry napless cloth.
10. Check the tip cone for foreign particles.
11. Grease the cleaned parts with the lubricant that comes with the pipette.

## 5 ml and 10 ml pipettes

The long-term service for 5ml and 10ml pipettes is the same as short-term service.

## Reassembly:

### 1-10 µl pipettes

1. Put the spring hatch 25, the spring 16, spring support 17 and the tube 18 back on the piston.
2. Slide the bigger O-ring 19, smaller O-ring 20 and tube 21 on the piston.
3. Slide the small spring 22, spring support 23 and O-ring 24 on the tube 21.
4. Carefully slide the entire assembly into the tip, then push the spring hatch 25 down and turn it 90 degrees.
5. Take the upper ejector top 11 between fingers and pull it down.
6. Push the tip cone into the handle while holding the ejector top 11 down, until you hear a "click".
7. Reassemble the lower tip ejector sleeve 13 (snap fitting).
8. Press trigger to reconnect the piston to drive mechanism.
9. Press READY to return from service mode.

### 5-50 µl pipettes:

1. Put the spring hatch 25, the spring 16, spring support 17 and the tube 18 back on the piston.
2. Slide the bigger O-ring 19, smaller O-ring 20 and O-ring support 21 on the piston.
3. Slide the small spring 22 on the piston.
4. Carefully slide the entire assembly into the tip, then push the spring hatch 25 down and turn it 90 degrees.
5. Take the upper ejector top 11 between fingers and pull it down.
6. Push the tip cone into the handle while holding the ejector top 11 down, until you hear a "click".
7. Reassemble the lower tip ejector sleeve 13 (snap fitting).
8. Press trigger to reconnect the piston to drive mechanism.
9. Press READY to return from service mode.

### 10-100 µl pipette:

1. Put the spring hatch 25, the spring 16, spring support 17 and the O-ring 20 back on the piston.
2. Carefully slide the entire assembly into the tip, then push the spring hatch 25 down and turn it 90 degrees.
3. Take the upper ejector top 11 between fingers and pull it down.
4. Push the tip cone into the handle while holding the ejector top 11 down, until you hear a "click".
5. Reassemble the lower tip ejector sleeve 13 (snap fitting).
6. Press trigger to reconnect the piston to drive mechanism.
7. Press READY to return from service mode.

### **30-300 µl pipette:**

1. Put the spring hatch 25, the spring 16, spring support 17 and the O-ring 20 back on the piston.
2. Carefully slide the entire assembly into the tip, then push the spring hatch 25 down and turn it 90 degrees.
3. Take the upper ejector top 11 between fingers and pull it down.
4. Push the tip cone into the handle while holding the ejector top 11 down, until you hear a "click".
5. Reassemble the lower tip ejector sleeve 13 (snap fitting).
6. Press trigger to reconnect the piston to drive mechanism.
7. Press READY to return from service mode.

### **100-1000 µl pipettes:**

1. Put the spring hatch 25, the spring 16, spring support 17 and the O-ring 20 back on the piston.
2. Carefully slide the entire assembly into the tip cone.
3. Push the spring hatch 25 down and turn it 90 degrees.
4. Take the upper ejector top 11 between fingers and pull it down.
5. Push the tip cone into the handle while holding the ejector top 11 down, until you hear a "click".
6. Reassemble the lower tip ejector sleeve 13 (snap fitting).
7. Press trigger to reconnect the piston to drive mechanism.
8. Press READY to return from service mode.

## **Short-term Service Multichannel pipettes**

If the pipette is used daily it should be checked and lubricated every three months. The servicing procedure starts with choosing the Service-mode from the menu (Menu -> Options -> Service).

1. Note that the tip ejector button is in fully up position.
2. Pull down the tip ejector part of the module and remove the tip cone module by pulling it out (snap fitting).
3. Pull out the Colour Ring 15. Open the upper end of the tip ejector slightly and remove the tip ejector. Pull out the module spring and clip 22.
4. Use a screwdriver to remove the four/six screws in the module cover and lift off the cover.
5. Remove the piston bar and clean the pistons and tip cones with a dry nap-free cloth.
6. If needed, replace the o-rings as described in Long-term Service
7. Grease cleaned pistons with the lubricant provided in the pipette package.
8. Install the piston bar with pistons and tip cones in the cover and close the cover with the four/six screws. Insert the clip 22.
9. Place the tip ejector and module spring on the neck of the module. Press the spring below the tip ejector. Close the tip ejector with the Colour Ring.
10. Push the tip cone module back to the handle while holding the ejector down, until you hear a "click".
11. Press trigger to reconnect the piston to drive mechanism.
12. Press READY to return from service mode.

## Long-term service Multichannel pipettes

If the pipette is used daily it should be serviced every six months. The servicing procedure starts with the disassembly of the pipette. The servicing procedure starts with choosing the Service-mode from the menu (Menu -> Options -> Service).

1. Note that the tip ejector button is in fully up position.
2. Pull down the tip ejector part of the module and remove the tip cone module by pulling it out (snap fitting).
3. Pull out the Colour Ring 15. Open the upper end of the tip ejector slightly and remove the tip ejector. Pull out the module spring and clip 22.
4. Use a screwdriver to remove the four/six screws in the module cover and lift off the cover.
5. Remove the piston bar and clean the pistons and tip cones with a dry nap-free cloth.

6. **100-1200 µl:** Pull out the tip cones from the pistons. Clean the cylinders 30, pistons and seal rings. If the seal ring is damaged, the whole piston assembly 31 must be replaced.  
Grease the seal rings and cylinders, avoid using too much lubricant. Install the cylinders back on the pistons.

**30-300 µl & 5-50 µl:** Open the tip cone by carefully releasing the cover ring from its snap joint with the screwdriver. Remove all the parts from the tip cone. Clean all the parts. If needed, replace the o-rings Take one piston. Slide cover ring 32 (larger hole), (support ring 35 30-300µl), spring 33, support ring 35, o-ring 37 bigger and o-ring 36 (smaller) onto the piston. Grease the o-ring with the lubricant provided in the pipette package. Slide all the parts into the tip cone and close the snap joint of the cover ring.

**1-10 µl:** Open the tip cone by carefully releasing the cover ring from its snap joint with the screwdriver. Remove all the parts from the tip cone. Clean all the parts. If needed, replace the o-rings Take one piston. Slide cover ring 32 (larger hole), support 35, o-ring 36 (bigger), o-ring 37 (smaller) and o-ring support 38 onto the piston. Then slide spring 39, spring support 40 (sharp edges first) and o-ring 41 onto the o-ring support 38. Grease the o-rings with the lubricant provided in the pipette package. Slide all the parts into the tip cone and close the snap joint of the cover ring.

7. Install the piston bar with pistons and tip cones in the cover. Place aligning studs to the same side when assembling the module. Close the cover with the four screws. Insert the clip 22.
8. Place the tip ejector and module spring on the neck of the module. Press the spring below the tip ejector. Close the tip ejector with the Colour Ring.
9. Push the tip cone module back to the handle while holding the ejector down, until you hear a "click".
10. Press trigger to reconnect the piston to drive mechanism.
11. Press READY to return from service mode.

# Service Instructions for Multichannel Pipette Tip Cones

To ensure even performance between all channels in a multichannel pipette, all tip cones have to be changed at the same time, if any of them needs to be changed. Don't mix tip cones of different packages, because one bag contains a matched set of tip cones. Place aligning studs to the same side when assembling the module. **See picture on page 35.**

## Replacing the battery

There are two versions of battery lids in Finnpiquette Novus Pipettes

- Follow the instructions below according to the battery lid version

### Opening the Version 1 battery lid

- Use a small flat screwdriver for opening the battery lid.
- Put the head of the screwdriver into the slot and rotate it to open the lid.
- Disconnect the battery connector and pull out the battery.

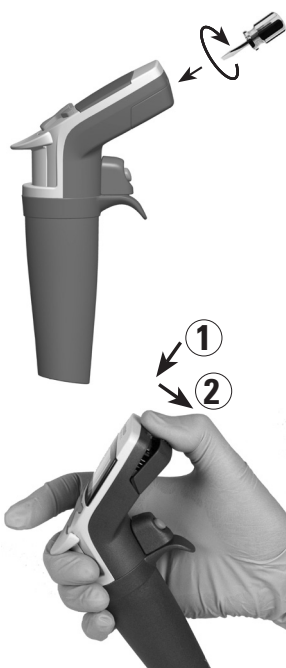

**Version 1**

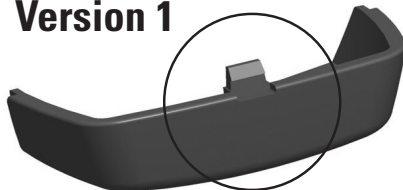

**Version 2**

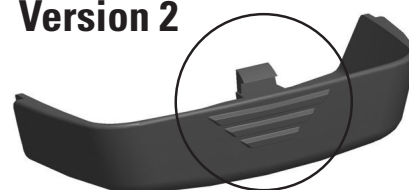

### Opening the Version 2 battery lid

- Open the battery lid by pressing and pulling the lid as shown in the picture.
- Disconnect the battery connector and pull out the battery.

**See page 6** for installing the battery.



**Note** Do not reuse version 1 style battery lid

## Sterilization Single Channel pipettes

The tip cone module can be sterilized by autoclaving it at 121°C (252°F) (2 ata) for 20 minutes. You can use steam sterilization bags if needed.

1. Remove the lower tip ejector sleeve 13 by pulling it out (snap fitting).
2. Push down the ejector button and take the upper ejector top 11 between fingers.
3. Release the ejector button to up position, but hold the tip ejector top 11 in down position with the fingers.
4. Remove the tip cone by pulling it out (snap fitting).
5. Press and hold the trigger down to drive out the piston.
6. Insert the special piston removal tool and pull out the piston 14. The number 2 end is for 300 µl and 1000 µl pistons, the number 1 end for all the smaller volumes. **See picture on page 21.** Release the trigger.
7. Remove spring hatch 25 by pressing it down and in the same time turning 90 degrees. Take out the spring 16.
8. Autoclave all module parts at 121°C (252°F) for 20 minutes.
9. Let the parts cool down to room temperature for at least two hours.
10. With pipettes up to 100 µl reassemble the plate 25 and spring 16.  
With pipettes 300 µl and 1000 µl reassemble the spring 16.
11. Attach the module back to the pipette as described in Maintenance section.

After autoclaving the module must be cooled to room temperature for at least two hours. Before pipetting, make sure that the module is dry. We recommend that you check the calibration after every sterilization cycle.

## Sterilization Multichannel pipettes

The tip cone module can be sterilized by autoclaving it at 121°C (252°F) (2 ata) for 20 minutes. You can use steam sterilization bags if needed.



**Note** The 1200 µl module is NOT autoclavable.

Remove and attach the module back to the pipette as described in Maintenance section. After autoclaving the module must be cooled to room temperature for at least two hours. Before pipetting, make sure that the module is dry. We recommend that you check the calibration after every sterilization cycle.

# TROUBLE SHOOTING

The table below lists possible problems and their solutions.

Defect	Possible reason	Solution
Leakage	Tip incorrectly attached	Attach firmly
	Foreign particles between tip and tip cone	Clean tip cones attach new tips
	Foreign particles between the piston, the O-ring and the cylinder	Clean and grease O-ring and cylinder.
	Insufficient amount of grease on cylinder and O-ring	Grease accordingly
	O-ring damaged	Change the O-ring
Inaccurate dispensing	Incorrect operation	Follow instructions carefully
	Tip incorrectly attached	Attach firmly
	Calibration altered: caused by misuse, for example	Recalibrate according to instructions
Inaccurate dispensing with certain liquids	Unsuitable calibration High viscosity liquids may require recalibration	Recalibrate with the liquids in question
No dispensing	Pistons stuck or not connected	Remove tip cone module. Move piston by hand or with piston removal tool. Attach the module in service mode.



**Caution** The Finnpiette is designed to allow easy in-lab service. If you would prefer to have us or your local representative service your pipette, please make sure that the pipette has been decontaminated before you send it to us.

Please note that the postal authorities in your country may prohibit or restrict the shipment of contaminated material by mail.

# Conversion Table

Value of the conversion factor Z ( $\mu\text{l}/\text{mg}$ ), as a function of temperature and pressure, for distilled water.

Temperature °C	Air pressure kPa						
	80	85	90	95	100	101.3	105
15.0	1.0017	1.0018	1.0019	1.0019	1.0020	1.0020	1.0020
15.5	1.0018	1.0019	1.0019	1.0020	1.0020	1.0020	1.0021
16.0	1.0019	1.0020	1.0020	1.0021	1.0021	1.0021	1.0022
16.5	1.0020	1.0020	1.0021	1.0021	1.0022	1.0022	1.0022
17.0	1.0021	1.0021	1.0022	1.0022	1.0023	1.0023	1.0023
17.5	1.0022	1.0022	1.0023	1.0023	1.0024	1.0024	1.0024
18.0	1.0022	1.0023	1.0023	1.0024	1.0025	1.0025	1.0025
18.5	1.0023	1.0024	1.0024	1.0025	1.0025	1.0026	1.0026
19.0	1.0024	1.0025	1.0025	1.0026	1.0026	1.0027	1.0027
19.5	1.0025	1.0026	1.0026	1.0027	1.0027	1.0028	1.0028
20.0	1.0026	1.0027	1.0027	1.0028	1.0028	1.0029	1.0029
20.5	1.0027	1.0028	1.0028	1.0029	1.0029	1.0030	1.0030
21.0	1.0028	1.0029	1.0029	1.0030	1.0031	1.0031	1.0031
21.5	1.0030	1.0030	1.0031	1.0031	1.0032	1.0032	1.0032
22.0	1.0031	1.0031	1.0032	1.0032	1.0033	1.0033	1.0033
22.5	1.0032	1.0032	1.0033	1.0033	1.0034	1.0034	1.0034
23.0	1.0033	1.0033	1.0034	1.0034	1.0035	1.0035	1.0036
23.5	1.0034	1.0035	1.0035	1.0036	1.0036	1.0036	1.0037
24.0	1.0035	1.0036	1.0036	1.0037	1.0037	1.0038	1.0038
24.5	1.0037	1.0037	1.0038	1.0038	1.0039	1.0039	1.0039
25.0	1.0038	1.0038	1.0039	1.0039	1.0040	1.0040	1.0040
25.5	1.0039	1.0040	1.0040	1.0041	1.0041	1.0041	1.0042
26.0	1.0040	1.0041	1.0041	1.0042	1.0042	1.0043	1.0043
26.5	1.0042	1.0042	1.0043	1.0043	1.0044	1.0044	1.0044
27.0	1.0043	1.0044	1.0044	1.0045	1.0045	1.0045	1.0046
27.5	1.0045	1.0045	1.0046	1.0046	1.0047	1.0047	1.0047
28.0	1.0046	1.0046	1.0047	1.0047	1.0048	1.0048	1.0048
28.5	1.0047	1.0048	1.0048	1.0049	1.0049	1.0050	1.0050
29.0	1.0049	1.0049	1.0050	1.0050	1.0051	1.0051	1.0051
29.5	1.0050	1.0051	1.0051	1.0052	1.0052	1.0052	1.0053
30.0	1.0052	1.0052	1.0053	1.0053	1.0054	1.0054	1.0054

# TECHNICAL DATA

## Battery

Type:	Li-ion battery
Capacity:	950 mAh
Charging time:	Approx. 1 h
Charging temperature:	0 to +45°C

## Power supply unit

Type:	Switching power supply
Input voltage:	100-240 V ~50/60 Hz, 300 mA
Output voltage:	5.0 V $\pm$ 500 mA

## Finnpipette Novus

Type:	148
Weight with battery (tip not included):	Single channel pipette 210 g max. Multichannel pipette 315 g max.
Operation:	Indoor use only
Altitude:	Up to 2000 m
Operating temperature:	+15 to +35°C
Air humidity during operation:	20 to 85% rel. humidit
Pollution degree:	2 according to IEC 60664-1*
Storage temperature:	$\leq$ 1 month -20 to +45°C (60 $\pm$ 25% Rel. humidity) > 1 month -10 to +35°C (60 $\pm$ 25% Rel. humidity)

It is recommended to charge the pipette every two months even if the pipette is not used.

\*) The pollution degree describes the amount of conductive pollution present in the operating environment. Pollution degree 2 assumes that normally only nonconductive pollution, such as dust, occurs with the exception of occasional conductivity caused by condensation.

# SPARE PARTS

## Single Channel pipette

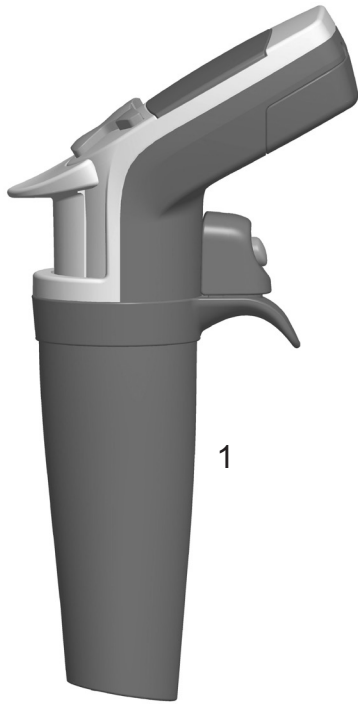

**1-10 ml**

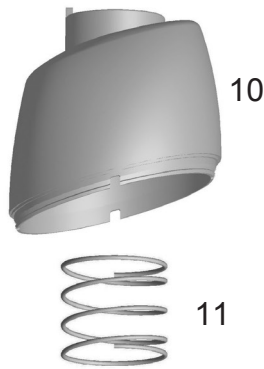

**0.5-5 ml**



**100-1000 µl**

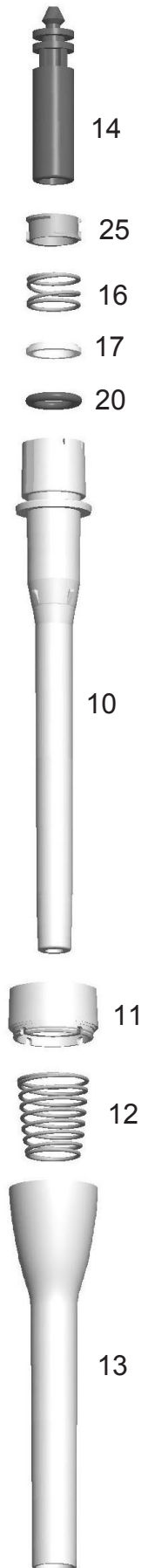

**1-10ml 2209580**

- 1. 2209680
- 10. 1062620
- 11. 1132390
- 12. 2209600
- 13. 1033050
- 14. 1060510
- 15. 1060530

**0.5-5ml 2209570**

- 1. 2209670
- 10. 1062610
- 11. 1132390
- 12. 2209590
- 13. 1030230
- 14. 1060790
- 15. 1060810

**100-1000µl 2209560**

- 1. 2209660
- 10. 1062030
- 11. 1062600
- 12. 1132180
- 13. 1062060
- 14. 1062360
- 16. 1132620
- 17. 1060630
- 20. 1030020
- 25. 1061350

**30-300 µl**

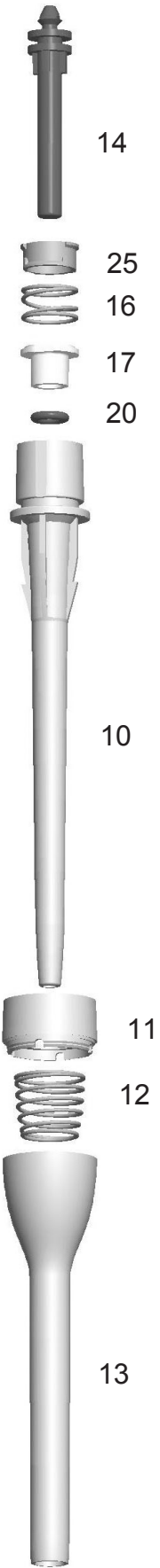

**10-100 µl**



**5-50 µl, 5-50 µl Micro**

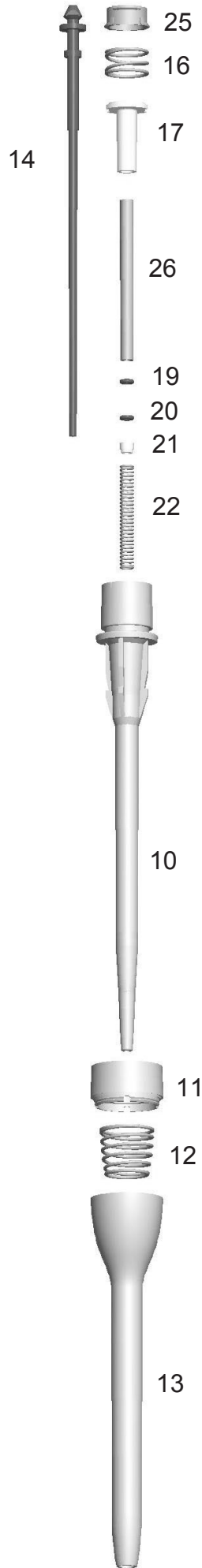

**1-10 µl, 1-10 µl Micro**



**30-300µl 2209550**

1. 2209650  
10. 1062020  
11. 1062590  
12. 1132180  
13. 1062050  
14. 1062250  
16. 1132620  
17. 1060620  
20. 1033180  
25. 1061430

**10-100µl 2209540**

1. 2209640  
10. 1062020  
11. 1062570  
12. 1132180  
13. 1062050  
14. 1062260  
16. 1132620  
17. 1060610  
20. 1030510  
25. 1061420

**5-50µl 2209530****5-50µl Micro 2209520**

1. 2209700  
1. 2209630 **Micro**  
10. 1062010  
10. 1062000 **Micro**  
11. 1062570  
11. 1062580 **Micro**  
12. 1132180  
13. 1062050  
13. 1062040 **Micro**  
14. 1062310  
16. 1132620  
17. 1060600  
19. 1030500  
20. 1033060  
21. 10593500  
22. 1132000  
22. 1132340 **Micro**  
25. 1060890  
26. 1061410

**1-10µl 2209510****1-10µl Micro 2209500**

1. 2209690  
1. 2209620 **Micro**  
10. 1062000  
11. 1062570  
11. 1062560 **Micro**  
12. 1132180  
13. 1062050  
13. 1062040 **Micro**  
14. 2207990  
16. 1132620  
17. 1060600  
18. 1060740  
19. 1030380  
20. 1030060  
21. 10593290  
22. 1131800  
23. 10593360  
24. 1030170  
25. 1060910  
26. 1061390

# SPARE PARTS

## Multichannel pipette

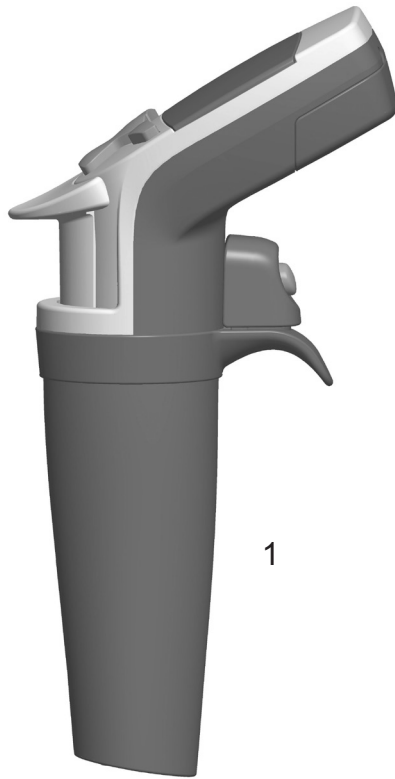

### 8-channel

14.	1062470
15.	1062460
16.	1062450
17.	1062380
18.	1062390
19.	1132470
21.	4x0202040
22.	1132490
23.	2x1062400
24.	2x1061300

### 12-channel

14.	1062470
15.	1062460
16.	1062440
17.	1062420
18.	1062410
19.	1132480
20.	2x0202020
21.	4x0202040
22.	1132500
23.	2x1062430
24.	3x1061300

### 16-channel

1.	2209790
14.	1062470
15.	1062460
16.	1062450
17.	1062380
18.	1062390
19.	1132470
21.	4x0202040
22.	1132490
23.	2x1062401
31.	2x11072010
32.	10593840
33.	2x1132130
34.	1132150
35.	2x10593500
36.	2x1030170
37.	10593870
42.	2207950 <b>8 pcs</b>

### 1-10µl

1.	2209760
31.	2209870
32.	1061020
34.	1131630
35.	10593280
36.	1030380
37.	1033160
38.	10593290
39.	1131900
40.	10593360
41.	1030170
42.	2209110 <b>12 pcs</b>

### 5-50µl

1.	2209770
31.	2208880
32.	1061020
33.	1131400
34.	1131630
35.	10589500
36.	1030480
37.	1030160
42.	2209090 <b>12 pcs</b>

### 30-300µl

1.	2209780
31.	10589170
32.	10589490
33.	1132810
34.	1131630
35.	1061980
36.	1033330
37.	1030550
42.	2212700 <b>12 pcs</b>

**1-10µl 8-ch 2209800**  
**1-10µl 12-ch 2209810**  
**5-50µl 8-ch 2209820**  
**5-50µl 12-ch 2209830**

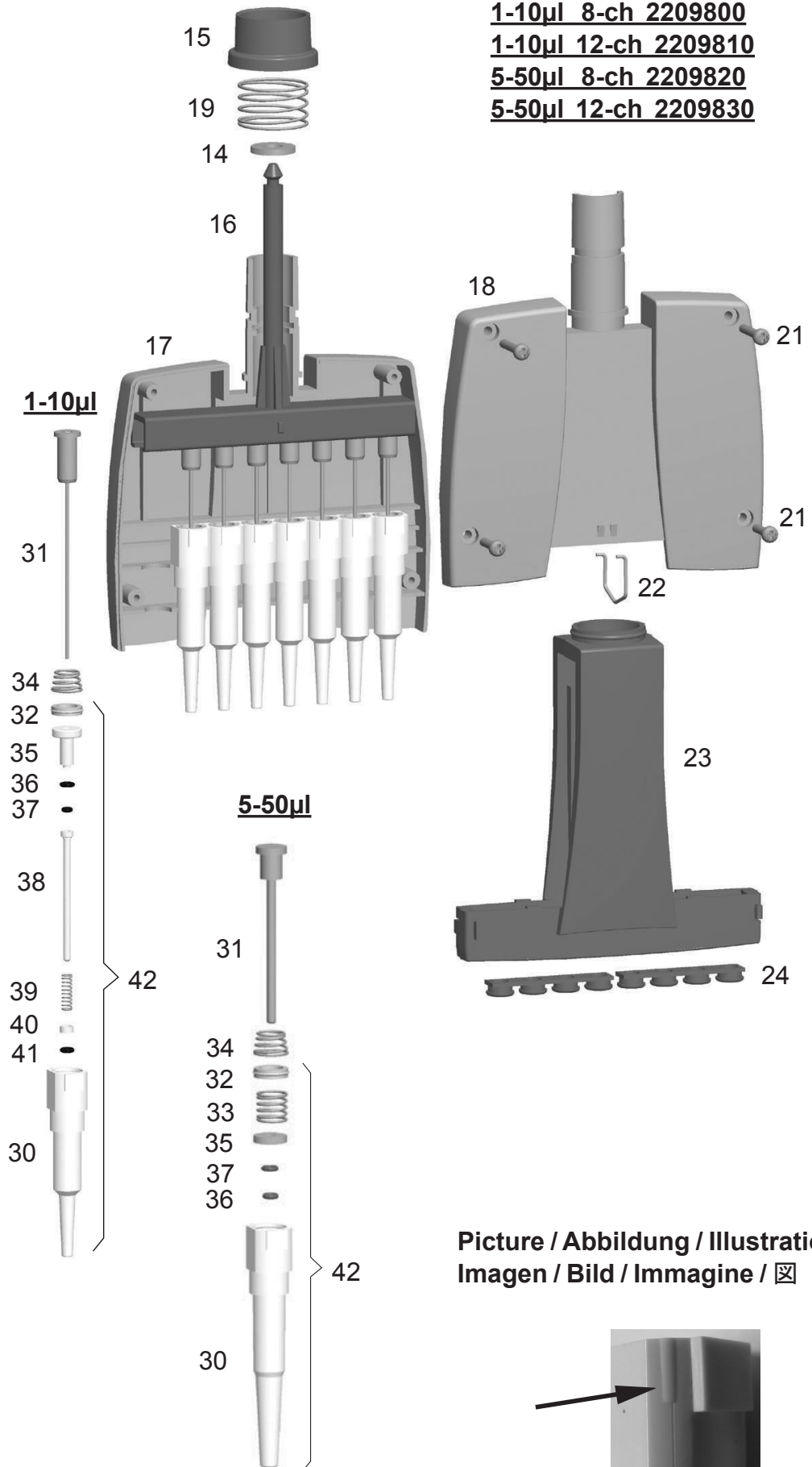

Picture / Abbildung / Illustration /  
 Imagen / Bild / Immagine / 𠄎

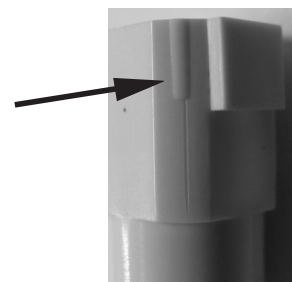

**30-300µl 8-ch 2209840**  
**30-300µl 12-ch 2209850**

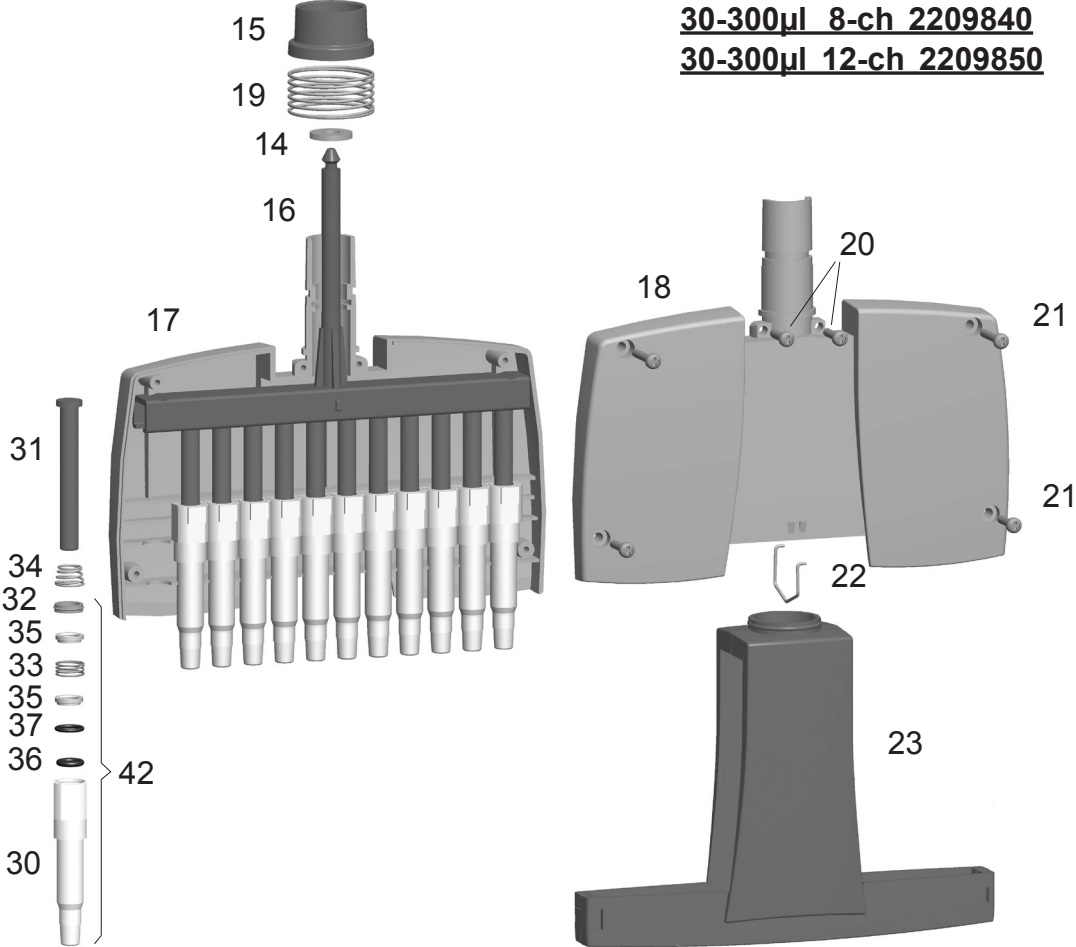

**5-50µl 16-ch 2209860**

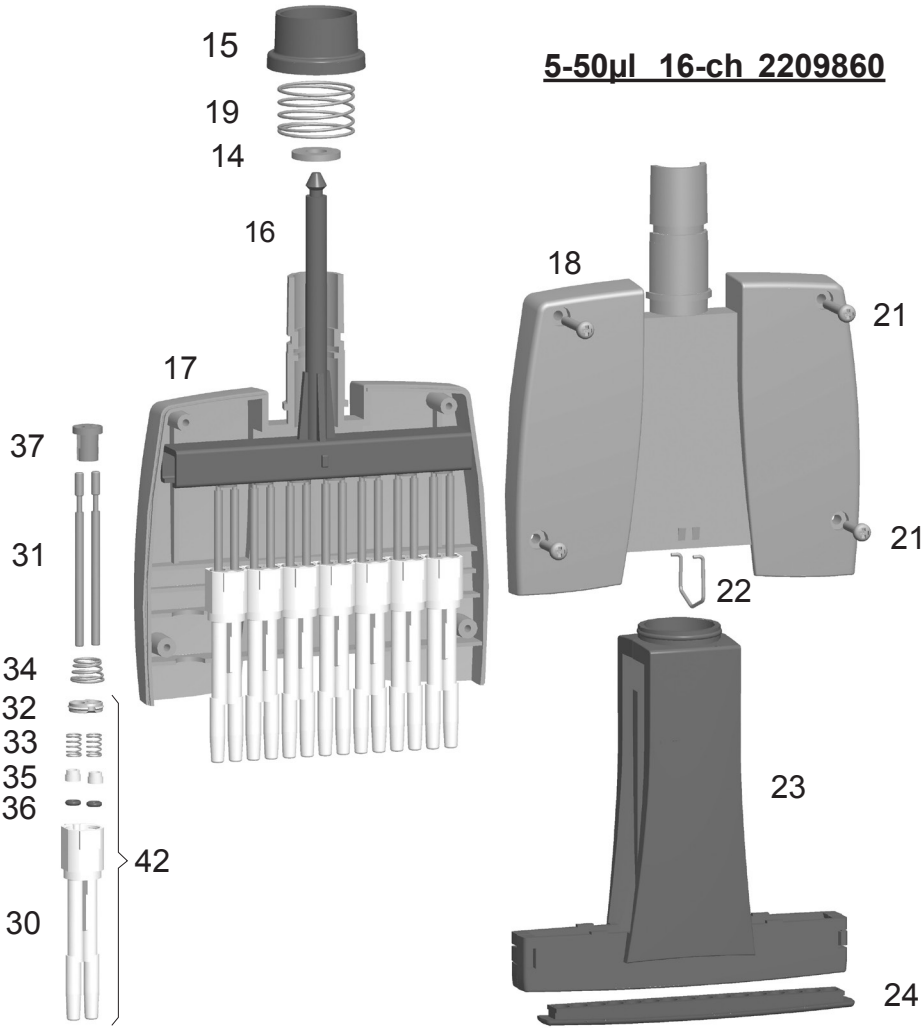

**1200µl 8-ch 2209930**

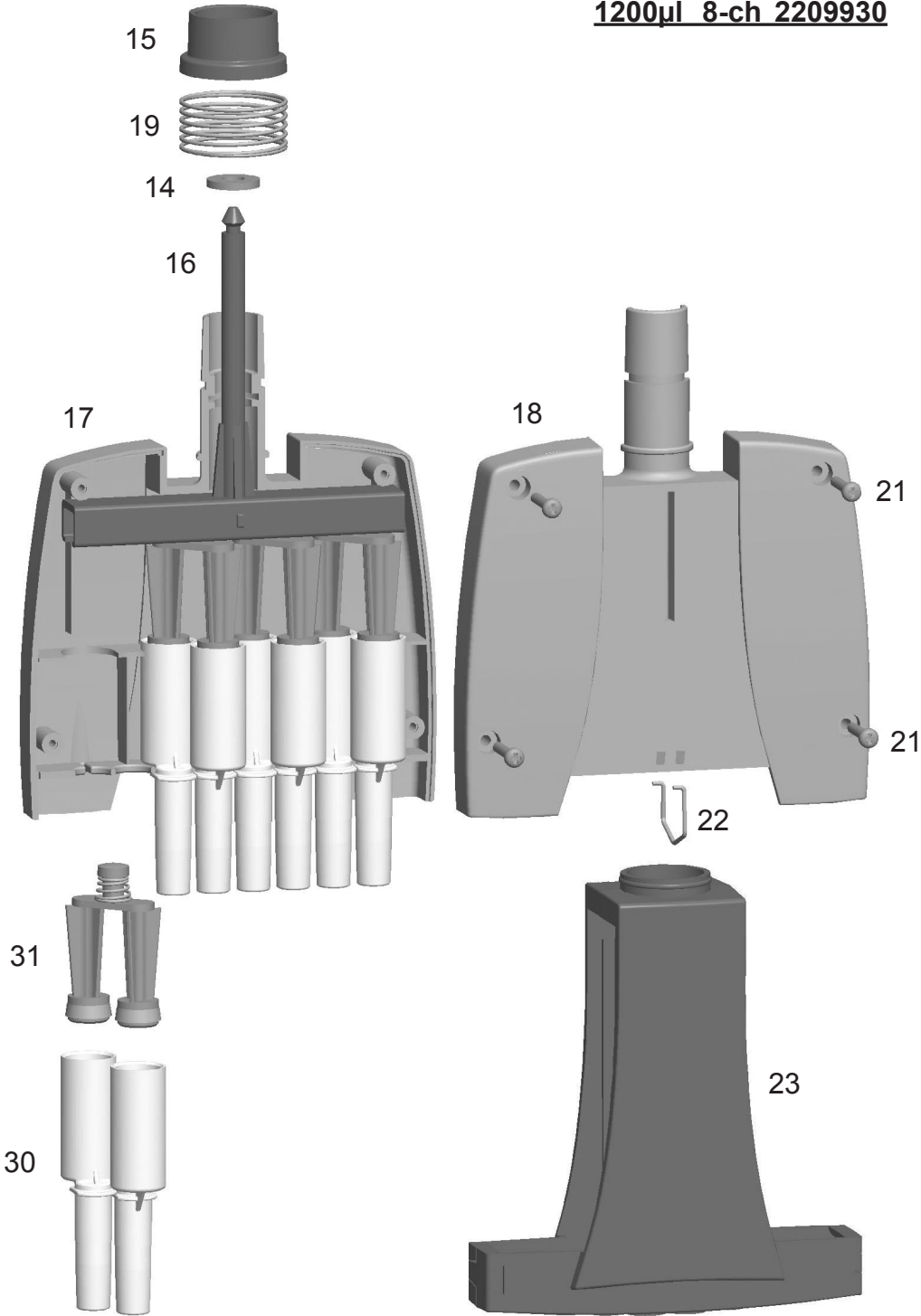

**1200 µl 8-channel**

- 1. 2209940
- 14. 1062470
- 15. 1062460
- 16. 1062780
- 17. 1062750
- 18. 1062740
- 19. 1132480
- 21. 4x0202050
- 22. 1132630
- 23. 2x1062760
- 30. 1062720
- 31. 2209920



## Tip Ordering Information

	<b>Code</b>	<b>Finntip</b>	<b>Volume</b>	<b>Qty</b>
*	9400300	10 Micro	0,2-10 µl	10x96/rack
	9400303	10 Micro sterile	0,2-10 µl	10x96/rack
*	94060100	Flex 10	0,2-10 µl	10x96/rack
	94060103	Flex 10 sterile	0,2-10 µl	10x96/rack
*	9400610	20 Micro	0,2-20 µl	10x384/rack
	9400613	20 Micro sterile	0,2-20 µl	10x384/rack
*	9400370	50 Micro	0,2-50 µl	10x384/rack
	9400373	50 Micro sterile	0,2-50 µl	10x384/rack
*	9400130	200 Ext	5-200 µl	10x96/rack
	9400133	200 Ext sterile	5-200 µl	10x96/rack
*	94060310	Flex 200	1-200 µl	10x96/rack
	94060313	Flex 200 sterile	1-200 µl	10x96/rack
*	9400260	250 Univ.	0,5-250 µl	10x96/rack
	9400263	250 Univ. sterile	0,5-250 µl	10x96/rack
*	9401250	300	5-300 µl	10x96/rack
	9401253	300 sterile	5-300 µl	10x96/rack
*	94060510	Flex 300	5-300 µl	10x96/rack
	94060513	Flex 300 sterile	5-300 µl	10x96/rack
*	9401110	1000	100-1000 µl	10x96/rack
	9401113	1000 sterile	100-1000 µl	10x96/rack
*	94060710	Flex 1000	100-1000 µl	10x96/rack
	94060713	Flex 1000 sterile	100-1000 µl	10x96/rack
*	9402070	5 ml	1-5 ml	5x54/rack
	9402073	5 ml sterile	1-5 ml	5x54/rack
*	9402160	10 ml	1-10 ml	5x24/rack
	9402163	10 ml sterile	1-10 ml	5x24/rack
	94060970	Flex 10ml Ext	1-10 ml	100 pcs/bag
	94060973	Flex 10ml Ext sterile	1-10 ml	50 pcs/bag

### \* Also available in bags

	<b>Code</b>	<b>Finntip Filter</b>	<b>Volume</b>	<b>Qty</b>
	94052000	10 Micro sterile	0,2-10 µl	10x96/rack
	94056980	Flex 10 sterile	0,2-10 µl	10x96/rack
	94052100	10 sterile	0,5-10 µl	10x96/rack
	94052020	20 Micro sterile	0,2-20 µl	10x384/rack
	94052150	20 sterile	0,5-20 µl	10x96/rack
	94052160	30 sterile	0,5-30 µl	10x96/rack
	94056510	Flex 30 sterile	5-30 µl	10x96/rack
	94052060	50 Micro sterile	0,2-50 µl	10x384/rack
	94052200	100 µl sterile	0,5-100 µl	10x96/rack
	94052310	100 µl Ext sterile	5-100 µl	10x96/rack
	94056520	Flex 100 sterile	5-100 µl	10x96/rack
	94052300	200 µl sterile	0,5-200 µl	10x96/rack
	94052320	200 µl Ext sterile	5-200 µl	10x96/rack
	94056380	Flex 200 sterile	1-200 µl	10x96/rack
	94052350	300 µl sterile	5-300 µl	10x96/rack
	94056580	Flex 300 sterile	5-300 µl	10x96/rack
	94052410	1000 µl sterile	100-1000 µl	10x96/rack
	94052430	1000 µl Ext sterile	100-1000 µl	5x96/rack
	94056710	Flex 1000 sterile	100-1000 µl	10x96/rack
	94052550	5 ml sterile	1-5 ml	5x54/rack
	94052600	10 ml sterile	1-10 ml	5x24/rack
	94056970	Flex 10 ml Ext sterile	1-10 ml	50/bag

This product is covered by patents issued in the US.

For patent coverage, see <http://www.thermofisher.com/pipetteip>

**thermofisher.com**

**info.pipettes@thermofisher.com**

© 2022 Thermo Fisher Scientific Inc. All rights reserved. All trademarks are the property of Thermo Fisher Scientific Inc. and its subsidiaries. Specifications, terms and pricing are subject to change. Not all products are available in all countries. Please consult your local sales representative for details.

**Thermo Fisher Scientific Oy**

Ratastie 2  
01620 Vantaa  
Finland

1509000-08-EN

**thermo**  
scientific