



# RADARMED 2500 CP

Manuale d'uso | User's manual | Mode d'emploi  
Gebrauchsanleitungen | Manual de instrucciones  
Руководство по эксплуатации



|  |           |
|--|-----------|
| <b>INDEX</b>   |           |
| <b>INFORMATION ON THE MANUAL</b> .....   | <b>1</b>  |
| WRITING CONVENTIONS .....  | 1         |
| <b>WARRANTY</b> .....  | <b>2</b>  |
| <b>NOTES</b> .....   | <b>2</b>  |
| <b>CAUTIONS</b> .....  | <b>2</b>  |
| <b>! WARNINGS !</b> .....  | <b>4</b>  |
| <b>INTRODUCTION OF THE TECNOLOGY</b> .....   | <b>5</b>  |
| <b>IN GENERAL</b> .....  | <b>6</b>  |
| <b>INTENDED USE</b> .....  | <b>7</b>  |
| INDICATIONS .....  | 7         |
| CONTRA-INDICATIONS .....   | 7         |
| <b>PRELIMINARY NOTES</b> .....   | <b>8</b>  |
| UNPACKING .....  | 8         |
| SETTING UP .....   | 8         |
| ACCESSORIES .....  | 8         |
| CONNECTIONS .....  | 8         |
| <b>DESCRIPTION OF THE EQUIPMENT</b> .....  | <b>10</b> |
| PROGRAMMING PANEL .....  | 11        |
| POWER SUPPLY BOARD .....   | 11        |
| .....  | 11        |
| <b>HOW TO USE OF THE DEVICE</b> .....  | <b>12</b> |
| BEST USE .....   | 12        |
| <b>SETTINGS</b> .....  | <b>13</b> |
| VARIOUS .....  | 13        |
| LANGUAGE .....   | 14        |
| DEFAULT .....  | 14        |
| TEST RADAR .....   | 15        |
| <b>FREE PROCEDURE</b> .....  | <b>15</b> |
| <b>LOADING PROGRAMS</b> .....  | <b>16</b> |
| <b>CREATE PROGRAMS</b> .....   | <b>16</b> |
| <b>MAINTENANCE</b> .....   | <b>17</b> |
| <b>ELECTROMAGNETIC INTERFERENCES</b> .....   | <b>18</b> |
| <b>TROUBLESHOOTING CHART</b> .....   | <b>18</b> |
| <b>TECHNICAL FEATURES</b> .....  | <b>19</b> |
| <b>APPENDICES</b> .....  | <b>19</b> |
| Appendix A - ENVIRONMENTAL CONSIDERATIONS .....  | 19        |
| Appendix B- LABEL .....  | 19        |
| Appendix C - INSTRUCTIONS FOR THE CONNECTION OF FEELER CABLE TO THE<br>MAGNETRON ..... | 20        |
| Appendix D – LIST OF THERAPEUTIC SUGGESTIONS .....                                     | 21        |
| Appendix E – ELECTRO-MAGNETIC COMPATIBILITY TABLES .....                               | 22        |

## INFORMATION ON THE MANUAL

This manual is addressed to:

- user of the machine;
- owner;
- responsible;
- people in charge of moving;
- installers;
- users;
- people in charge of maintenance.

This document provides valuable information regarding the installation, set up and use of RADARMED 2500 CP equipment.

It is a useful and essential reference guide for the user: read the contents of the manual carefully before installing the equipment and keep it on hand at all times for future reference.

It is of vital importance that you strictly adhere to the recommendations contained within the manual in order to avoid malfunction, which may cause damage to the equipment and consequent annulment of the validity of the warranty.

Furthermore, in order to obtain the highly efficient technical service available from the manufacturer, it is essential that any handling of the equipment be in accordance with the instructions provided.

The limits of this manual are:

- the user manual cannot replace proper experience;
- the user manual, for particularly difficult operations, can only be a reminder of the main operations.

The manual is to be considered part of the equipment and must be preserved for future reference until the decommissioning of equipment. The operating instructions must be available for consultation in the vicinity of the machine and properly stored.

This manual reflects the state of the art at the time of sale and cannot be considered inadequate because later updated based on new information. The manufacturer has the right to update products and manuals without necessarily updating preceding products or manuals unless these have implications for the safety of the device.

The company will not assume any responsibility for any major cases:

- improper use of the machine;
- use against to specific national regulations;
- incorrect installation;
- defects in power;
- serious shortcomings in maintenance;
- changes and unauthorized interventions;
- use of parts or materials not specific to the model;
- total or partial non-observance of the instructions;
- exceptional events.

If you would like any further information, please get directly in touch with the company EME srl, to stay up to date on the best ways to use these machines and to receive the necessary assistance.

### WRITING CONVENTIONS

Certain sections of the manual have been underlined in order to highlight their importance.

#### NOTE

These contain important information and useful tips for operating the equipment

#### CAUTIONS

The CAUTION message appears before operations, which, if not correctly performed, may cause damage to the machine and/or its accessories.

#### ! WARNING !

This signals operations or situations, which, if unknown to the operator, or incorrectly carried out, may harm the operator.

## WARRANTY

EME srl guarantees the quality of its products for a period of 24 months from the date of purchase, when information contained in this manual regarding installation, use and maintenance is strictly adhered to and the warranty coupon is returned within 15 days of purchase.

The guarantee covers the replacement of faulty parts.

The warranty does not however, include the replacement of the equipment.

The warranty does not cover any malfunction or damage caused by:

- 1) incorrect connection and installation;
- 2) incorrect use due to non-compliance with instructions contained in this manual;
- 3) use of the machine in environmental conditions which do not conform with those specified for the product;
- 4) improper or inadequate maintenance;
- 5) unauthorized opening of the outer casing;
- 6) tampering or unauthorized modifications;
- 7) use of non-original accessories.

EME srl registered offices provide the warranty.

Should you need to return the goods then please note the packing instructions as follows. Enclose a copy of the purchasing receipt.

You should insure the postal package.

Before sending the machine back for suspected malfunction, we recommend that first you carefully consult sections regarding MAINTENANCE and TROUBLESHOOTING of the manual, as a large part of the problems and faults are usually due to inadequate maintenance or small technical problems which can often be easily solved by the user himself.

A simple call to EME srl technical department may prove to be the solution to the problem .

When re-packing the equipment for return to the manufacturer, proceed as follows:

1. unplug the machine and any connections, devices, applicators etc;
2. carefully clean and disinfect all parts of the machine and accessories which have

been in contact with patients.

Any equipment which the technical department does not consider hygienic (Italian law T.U.S. 81/2008 on safety in the workplace) will not be accepted;

3. disassemble accessories and any mechanical supports;
4. use original box and packing materials;
5. enclose Service Request Form (available from the manufacturer) on which to write detailed informations regarding the nature of the problem in order to facilitate the technical department's intervention and save time on repair.

## NOTES

### PRELIMINARY NOTES

- The installation of the device does not require any special care, is therefore simple and immediate.

### USE

- Each time you click the START button or the STOP button the machine will emit a long confirmation beep.
- Each time you select the SMART-CARD will take a few seconds to allow the machine to recognize and load the card: meanwhile it shows the message PLEASE WAIT.
- The selection of the SMART-CARD is possible only if previously inserted into the slot.
- To prevent erasure or formatting of SMART CARD, confirmation is required.
- During the operation is normal to note a certain heating of the RF cable, which is proportional to the power output.
- To navigate the software it is necessary to use the encoder knob that can: rotate (both clockwise and anticlockwise) by moving the selection of an option, or confirm the selection by pressing the knob itself.
- The keys shown on the display are touch.

### MAINTENANCE

- For an optimal use of the device and to guarantee its maximum performance, it is recommended to perform maintenance at the correct time and suggested ways.

## CAUTIONS

### PRELIMINARY NOTES

- The customer is liable for all damage caused by inadequate packaging of the material. Keep the original packaging of the unit: it will be needed if the unit is returned to the company.
- Do not use the equipment in places where it might get wet.
- Before operating the machine carefully check the correctness of the connections according to the instructions.
- To avoid the risk of electric shock, this device must only be connected to power supply networks with protective earth.

- Do not use accessories other than the ones provided: they might damage the unit, causing the warranty to become void. In case you have any problems or difficulties with installation, contact EME srl technical support.
- If using the same extension for the unit and other units, make sure that the total current being absorbed by the connected units, does not exceed the max current allowed for that type of cable and that, however, it does not exceed 15 A.
- The therapeutic suggestions are stored in the permanent memory of the machine. These protocols can be edited but not possible to save any changes.
- The protocols of therapeutic suggestion preloaded on the machine cannot be deleted.
- It is not possible to define a number of sessions suggested to evaluate the effectiveness of the treatment, since they are related to the power delivered to the patient undergoing treatment. E 'task of the physician to decide the number of therapy sessions which subject the patient according to the specific requirements of the case, in order to ensure to the patient himself the execution of an effective treatment in time and place in conditions of absolute safety.
- Always control sometimes the integrity of the cable and of the probe/applicator connector: they must not be damaged or worn.
- CLASS A device suitable for use in all establishments other than domestic and those directly connected to the public low-voltage power supply network that supplies buildings used for domestic purposes.
- Do not use the machine near HF SURGERY DEVICES and rooms with an RF shield of an EM system for magnetic resonance, in which the intensity of the EM DISORDERS is high.
- No modification of this device is allowed.
- The use of accessories, transducers and cables, other than those specified or supplied by EME srl, could lead to higher electromagnetic emissions or a decrease in the level of electromagnetic immunity of the appliance, with consequent incorrect operation.
- The EMISSION characteristics of this device make it suitable for use in industrial and hospital environments (Class A of CISPR 11). If used in residential environments (for which CISPR 11 class B is normally required) this equipment may not offer adequate protection for radio frequency communication services. The user may have to apply noise mitigation measures, such as relocation or re-orientation of the equipment

#### USE

- On request we can provide the user manual in electronic form.
- Because of security reasons, the only specific software must be loaded into each machine. In case of exchange of software, the machine may immediately stop all its functions, requiring the intervention of EME srl technical assistance.
- The Smart Card has to be introduced keeping the golden chip facing up.
- A new Smart-Card has to be initialized using FORMATTING before being used.
- If the card is introduced in wrong way or is not formatted or results not correct, a warning window will appear with the information about the error. Close the window clicking OK to continue.
- SMART-CARD option is visible (and therefore selectable) only if the smart-card is properly inserted in its slot. In case of lacked insertion of the Smart-card in its slot or Improper insertion, the option button SMART CARD is not visible, for which a possible selection does not involve any action.

- The selection of programs to be loaded takes place by default in the user memory, that in cases of non-presence of the Smart-card (due to its lack or to an improper insertion in its slot) is the only support of available memory to load customized programs.
- In addition to possible problems of compatibility issues in the connectors, the machine does not work properly with antenna not specifically manufactured for its use with RADARMED 2500 CP. If trying to use different types of antennas / applicators, it can cause possible damages on the machine, rendered null and void the warranty
- In case of excessive overload the intervention of a protection is provided and the operation with device is interrupted. If this condition occurs, unplug the power cable for about 10 minutes. After this time, the device will automatically reset.
- The distance of the antenna from the area to be treated should not be too much less than the wavelength (About 12 cm) neither too big, to prevent excessive dispersion of the radiation beam: the more increases the distance between the antenna and the body part to be treated, the lower is the effectiveness of the treatment
- It is recommended to graduate very slowly the level of RF power that must be supplied by the machine. The optimal level for a given therapeutic application is obviously a "subjective": it would be very inconvenient (and dangerous) to take, even if the same treatment, the same irradiation dose for all patients. It is based on experience and professional training of the operator which must be addressed in appropriate way to use correct parameters to set them on the machine.
- The appliance or the system must not be used near other equipment and, if it is necessary to use it near other equipment, the medical electrical equipment must be observed to check normal operation in the configuration in which it is used.
- If the electro-medical device, interacting with another device, causes or receives detectable interferences, the user is invited to limit the interference by adopting one or more of the following measures:
  - o Reorient or reposition the receiving device;
  - o Increase the distance between the devices;
  - o Connect the equipment to a scale of a circuit different from or to devices that cause interference;
  - o Contact the manufacturer or local technician for assistance.
- Portable and mobile radiocommunication devices can affect the operation of the device.
- transportable RF communication equipment (including peripherals such as antenna cables and external antennas) should be used at a distance not less than 30 cm (12 inches) from any part of the device, including the specified cables. Otherwise, the performance of this device may be degraded.

#### MAINTENANCE

- Use the probes/applicators with care: any misuse may affect their performance and features.
- Under no circumstances technicians not authorized by EME srl are allowed to open and/or disassemble the probe/applicator: such tampering, besides damaging its characteristics, immediately invalidate the right to warranty.
- The equipment should never be disassembled for cleaning or inspection purposes: the units does not have to be cleaned internally, and if for some reason the unit must be opened, it should only be done by specialized technicians authorized by EME srl.

- Do not use thinners, detergents, acid solutions, aggressive solutions or flammable liquids to clean the external parts of the unit and accessories. Using these substances, or misusing the accessories, will cause the immediate voiding of all warranty rights, as well as irreparably damaging the unit and the accessories.
- For optimal use of the apparatus and to ensure its optimum performances it is recommended to perform properly within the time and in the manner recommended maintenance actions.
- For a correct replacement of the installed fuses, observe the following indications:
  1. Disconnect the power supply and open the fuse box using a screwdriver, making sure you insert the screwdriver in the slot on the fuse box and levering up outwards;
  2. insert a screwdriver into the two side holes for fuse expulsion
  3. remove the old fuses
  4. insert a new fuse at a time by using a slight pressure to the left, with a finger
  5. push the box back to fit into the slot
- It is recommended to perform periodic maintenance every two year, in order to check:
  - o the intensity of any leakage currents;
  - o the continuity and thus the integrity, of the ground conductor;
  - o the correctness of the value of insulation resistance;
 in order to ensure the electrical safety of the device, ensure that it is operating in a safe guaranteed. For this kind of intervention you should contact a qualified service technician or alternatively EME srl or one of its authorized service centers.
- Be careful not to exert torsion and traction on the coaxial cable to the antenna / user: you may risk damaging the electromechanical characteristics of the cable, significantly degrade the electrical isolation, with severe reduction in machine performance.
- Before you press the START button verify that the antenna is connected properly. Trying to use RADARMED 2500 CP without the antenna connected , may produce serious damage to the unit and will void automatically, the warranty.

#### WORKING PROBLEMS

- Only technicians authorized by the manufacturer may access the interior of the unit.
- You should contact EME srl or its authorized service centers for any repair work or further information.

## ! WARNINGS !

#### PRELIMINARY NOTES

- The perfect functionality of the device is guaranteed in accordance with the rules of installation and of use included, only with original accessories and spare parts.
- If there are problems or installation difficulties, please contact the EME srl technical assistance department.
- Before connecting the cable to the mains plug, check that the equipment wasn't damaged during transport. Ensure that the power supply specifications on the mains socket correspond with the information on the label attached to the back of the unit.
- The electric current that powers the unit is VERY DANGEROUS. Before connecting or disconnecting the power cable from the connector on the unit, make sure it is plugged out from the mains socket.

- The power cable has an earthed plug for safety reasons.
- Only use with a mains socket suitable for use with earthed systems
- **The equipment should only be connected to electrical systems that fully comply with regulations.**
- If you are using extensions of the socket, check that the ground is present and that it is intact.
- Connect the device directly to the wall socket possibly without using extensions. If you do not respect this warning, there may appear electrical discharges to persons and the function of the device may be altered.
- The correct position of transport of the machine provides that the apparatus is moved exclusively along the side of the arm radar toward the opposite side, by gripping it with both hands on the curved profiles of the cover
- To avoid danger of tipping properly tighten the joints of the arm when it is determined the distance of the antenna from the part of the body to be treated.
- The output power must be turned off when you are making the positioning of the antenna radiating treatment.
- The manufacturer is held responsible for the fundamental safety, reliability and performance of the device only if:
  - o The electrical system of the premises complies with the appropriate regulations;
  - o The device is used in accordance with the instructions for use.

#### USE

- In the indicated temperature range, during normal use, the rectangular antenna can reach temperatures of 54 ° without endangering the patient's health.
- In order to ensure the functioning of the machine in conditions of absolute safety for the patient, the operator must pay attention to the necessity of a periodic maintenance (every 2 years) of the equipment. EME srl authorized personnel should carry out such operations.
- It absolutely forbidden the use of the device in the presence of a flammable anesthetic mixture and oxygen-rich environments. In case of non-compliance with this indication, EME srl will not be responsible for any accidents.
- It is absolutely forbidden to cover the ventilation slots: such an action may not allow the machine to work in safe conditions. In case of non-compliance with this indication, EME srl will not be responsible for any accidents.
- It's important to pay the attention of the operator to the necessity to verify the correctness of the electric installation of device before activating the supply switch.
- It is advisable to suspend the therapeutic treatment if it were to appear some disturbances during its emission.
- It's strongly advised not to hold the device on in state of start without using the probe, it could overheat.
- If the button OK is pressed to confirm the software updating before having connected the USB-port to the source containing the software updating, the device goes out from the main program and enters in the updating routine waiting for the USB connection. A screen indicates the missed connection. If the support to connect to carry out the updating is not available, it is necessary to switch off the device and turn it on again through the general switch to restart the device with the available software.

- DO NOT EVER ORIENT THE RADIANT ANTENNA TOWARDS THE EYES OR GENITAL ORGANS.
- In the case of specific therapeutic applications may be necessary to use protective glasses by microwave.
- The RADARMED 2500 device emits radiation that could compromise the operation of electrical and electronic equipment.
- There may be potential risks due to the presence of **objects or materials located in the vicinity of the patient** during an application of radar-therapy.
- Microwave energy is not applied in particular to people with jewels non deve or wearers clothes containing metal or metal (such as buttons, clasps or wires).
- **The patients with cardiac stimulators (pacemakers) or implanted electrodes can not be treated with microwave applications and must be kept at a safe distance, away from the area of operation of these and similar equipment.**
- Any hearing must be removed from the ear of the patient. The body parts of the patient including metallic implants (eg intra-medullary or dentures) **should not be subjected to microwave treatment without express authorization specialized medical.**
- In the case of treatments of restricted areas of the body (such as a wrist), the radiating antenna must be positioned so that areas **particularly "sensitive"** (for example, eyes and genitals) **not they are exposed along the radiation beam.**
- During an application of microwave therapy, people are not subjected to such treatment must maintain a distance of at least 1.5 meters from the' antenna radiating.
- During the emission of the treatment it is necessary to remain behind the antenna;
- Keep the machine (and therefore the antenna) at a distance of at least 5 meters from an obstacle (a wall of cement, for example);
- ABSOLUTELY AVOID that in front of the antenna there is a metal wall.

#### MAINTENANCE

- For safety reasons before carrying out any maintenance or cleaning the unit, **YOU MUST turn off the equipment with the power switch at the back and unplug the socket connected to the mains.**
- Before every treatment, it is recommended to clean with caution all of the accessories and the parts of the equipment that have been to contact with the patient.
- The operator must pay attention to the necessity of a periodic maintenance (every 2 years) of the probes/applicators. EME srl authorized personnel should carry out such operations.
- The cleaning and disinfection must be done systematically before the therapeutic treatment which subject the patient.
- Do not use thinners, detergents, acid solutions, harsh solutions or flammable liquids to clean the outside of the unit and its accessories. The use of these substances, with the improper use of accessories, irreparably damages the equipment and the warranty will lapse.
- Always control sometimes the integrity of the cable and of the probe/applicator connector: they must not be damaged or worn.
- It is advised that personnel with technical preparation substitute the fuses, to perform the **operation in safety conditions.**
- Do not open the device: inside there are high voltages that may be hazardous.

- Only personnel authorized by the manufacturer may access the internal components. For repairs and further information please contact EME srl or its authorized service centers.

#### WORKING PROBLEMS

- Do NOT OPEN the unity, as HIGH VOLTAGE ELECTRICITY is present and may prove VERY DANGEROUS.

## INTRODUCTION OF THE TECNOLOGY

On a tissular level, the transformation of energy into heat has precise posologic rules; in fact when monitoring hyperemia as a quantifiable biological response to heat it is necessary to **respect certain times and doses** during temperature increase.

It is also necessary to take into account the **speed of "administration"**, which in this case is the speed of the increase of the temperature itself.

This latter aspect, which should not be overlooked, influences the choice of treatment in so far as the responses of the thermo-receptors (the heat terminus organs of Ruffini) become more pronounced the faster the heat increases. There are approximately 210,000 points of thermic sensitivity although there are in fact far more cold points than heat points. In an adult, each square centimetre of skin has between 6 and 23 cold points yet only 0 to 3 heat points.

The stimulus averted by the nerve endings is the temperature variation yet if this variation is too strong and too fast then the stimulation is perceived by the pain reception points.

This is one of the reasons why the gradual and quantitatively "controllable" heating permitted by radar-therapy makes it particularly manageable and effective in thermo-therapy applications.

Normal applications of heat treatment (including short-wave therapy) are generally used to treat the following conditions:

- reduction of pain,
- improvement in collagen extendibility,
- reduction in articular rigidity,
- reduction of oedema and inflammatory exudates,
- increase in blood flow.

There are two main reasons why it is believed to cause a reduction in pain :

- o **indirect analgesic action**, secondary to the action on the algogenic components (muscular spasm and hypoxia);

- **direct analgesic action:** the most commonly accepted explanation for this is based on the presumed “counter irritating” effect of heat according to the gate control theory of Melzack and Wall.

Two partially contradictory factors must be considered however regarding the counter irritating effect: the heat increase effect on nervous conduction and the role of thermoreceptors.

The heat increase effect regards the fact that the increase in temperature, obviously within certain limits determines a proportional increase in the nerve trunk conduction velocity.

The problem is more complex for heat receptors. Heat nociceptors respond at temperatures higher than 45° in the receptive areas. This is the threshold of heat pain in man. Polymodal receptors however respond to all types of harmful stimulation (heat, mechanical, and chemical).

Microwave therapy, or short wave therapy is important for applying heat in physiotherapy. This type of heat therapy uses radio waves with wavelengths of 10÷12.5cm and with a frequency of about 2.5 billion cycles per second. This is the method used in radiation heat therapy. Medical use of microwaves is mainly based on the fact that the microwaves are **selectively absorbed by tissues with high water content**. They can therefore heat certain selective areas such as muscles for example, while the penetration and absorption at bone level is minimal.

Once electromagnetic waves come in contact with organic tissue, they transform most of their radiating energy into heat (caloric energy) with different degrees of penetration mainly limited to muscular and peri articular tissues (skin and subcutaneous, tendons, sheaths, muscle bands, synovia). The penetration power of centimetric waves is however, good.

The production of heat is inversely proportional to the electric resistance of tissue and is at its maximum in muscular tissue (that contains a lot of water) and at its minimum in adipose tissue. The optimal penetration of the microwaves is around 3-4cm.

However it has been calculated that at the interface between subcutaneous fat and muscle, there is notable microwave reflection with the result that a large quantity of energy is converted into heat at the subcutaneous tissue level. Therefore in obese persons, that have difficulty in getting good deep muscular radiation when some areas of the body are being treated like the thigh or the buttocks or the cervical rachis (patients with the so-called “camel’s hump”: accumulation of fat at the base of the neck).

It goes without saying that microwave therapy has a capacity to produce deep heat in tissues (as stated 3÷4cm). This is inferior in an absolute sense to the depth obtained with marconi therapy (5÷7cm) but microwave therapy is much more manageable and selective than marconi therapy as you can get a higher ratio of heat in the muscular and cutaneous tissues.

Microwaves cause intense active arteriole vasodilatation and delay the onset of muscle fatigue.

## IN GENERAL

EMEsrl has recently developed a complete series of apparatus, accessories and equipment, designed and manufactured according to the highest standards of quality, making use of the latest technology and fully adhering to current directives and norms.

Particular attention has been paid to the design, easy operation, function and safety of the equipment and the final result is this modern, compact unit, which offers an extremely logical operative sequence supported by a clearly legible display .

A wide range of therapeutic applications, and guaranteed patient and therapist safety ensure that equipment is of the highest quality.

The equipment were planned and built in manner that their use, if it happens at the conditions indicated, doesn’t compromise the health and safety of the patients, of the users and of third, taking into consideration the benefit to the patient.

Such equipment are not bound to diagnosis, prevention, monitoring, compensation of injury or handicap, substitution or modification of the anatomy, control of the conception, support/vital support of functions but allow to treat special pathologies and to reduce the illness.

A special intervention is not required in the event of failure of the medical device, but just a normal maintenance/repair.

## INTENDED USE

RADARMED 2500 CP is an electro-medical device that delivers treatments of radartherapy, using a special antenna that delivers the treatment.

The use of these equipments is reserved for operators such as physiatrists, physiotherapists, and pain therapists that, by their training, provide assurance of proper use and safe for the patient.

In fact, the operator must be appropriately qualified and he carefully studied the contents of the user manual in order to use the device; or, it must operate under the supervision of a health professional adequately qualified to use the machine, able to understand the benefits and the limits of therapy and to work in conditions of safety for the person undergoing treatment.

Such equipment can be used in hospital environment outpatient, nevertheless, it is important to know that the user follow the medical instructions to use the equipment or that he follow the indications present in the user's manual.

RADARMED 2500 CP is a machine produced according to the Directive MED 93/42/EEC concerning medical devices.

## INDICATIONS

The processing of radar therapy are supplied under the following conditions:

- Knee osteoarthritis;
- Rotator cuff tendinopathy;
- Low back pain;
- Muscle stiffness;
- Cervical myofascial syndrome;
- Carpal tunnel syndrome;

## CONTRA-INDICATIONS

The treatments of radartherapy cannot be delivery in case of:

- metal in the area;
- peripheral arteriopathy;
- cardiopathy;

- acute inflammation;
- gout;
- hypertensive vasculitis;
- fertile metaphysis (high doses may cause reduced bone growth);
- great care should be taken when treating the area near the testicles as they are sensitive to heat and are easily exposed to dispersion during therapeutic applications in the area or in the vicinity (temperature increases may cause spermatogenesis problems);
- do not use near the eyes. It may cause lenticular opacity of the lens;
- people with active implantable device (they should not be admitted into the treatment area;
- pregnant women;
- people with significant articular effusion;
- people with metal braces or false teeth containing amalgam are not advised to undergo microwave treatment.
- Patients with cancer

## PRELIMINARY NOTES

### UNPACKING

The equipment is specially packaged for transport in a single pack complete with filling which has been specifically studied for safe transportation and storage.

To remove the equipment from the pack, place the box on a smooth, flat surface. Open the top of the box and remove the polystyrene filling.

Be very careful when removing the contents of the pack.

The unit and accessories are wrapped in transparent sheets of polyethylene protection and contains the following:

- the User Manual;
- n.1 mains power supply cable;
- n.2 spare fuses (see technical specifications);
- n.1 pantograph arm;
- n.1 output cable high frequency;
- n.1 circular feeler;
- n.2 Grower 5mm
- n.2 8mm nut
- n.1 8-nut nut wrench

Check the contents of the package and should any of the items be missing then contact your local authorized EMEsrl dealer.

### SETTING UP

Installation of the radar therapy equipment is fast and simple.

Position the device in such a way that the operator can remain behind the antenna during treatment delivery.

It is also important to keep the machine (and therefore the antenna) at least 5 meters away from an obstacle (eg a concrete wall) and it is absolutely necessary to avoid that there is a metal wall in front of the antenna.

Once the device is positioned, lock the wheels with the special brake to prevent unintentional movements.

The following environmental conditions are ideal when installing the equipment:

- room temperature: from +10° to +40°C;
- humidity level: from 10% to 80% without condensation;
- avoid direct exposure to sunlight, chemical products and vibrations;
- avoid using RF wireless communication devices in proximity (<0.30m).

In the indicated temperature range, during normal use, the rectangular antenna can reach a temperature of 54 ° without endangering the patient's health.

### ACCESSORIES

The devices can be used with the following accessories:

| Description                                      | Included | Optional |
|--|----------|----------|
| Power cable supply                               | 1        |          |
| Spare FUSES (see technical specifications)       | 1        |          |
| User manual                                      | 1        |          |
| Radar cable high frequency                       | 1        |          |
| Orthostatic pantograph arm for radartherapy      | 1        |          |
| AC-circular feeler diam.17cm                     | 1        |          |
| Grower 5mm                                       | 2        |          |
| 8mm nut  | 2        |          |
| 8-nut nut wrench                                 | 1        |          |
| AR-rectangoular feeler 47x12x7                   |          | x        |
| A3D-3-dimensional antenna with surrounding field |          | x        |
| Smart-card                                       |          | x        |
| Kit software update                              |          | x        |

The ACCESSORIES that can be replaced by the RESPONSIBLE ORGANIZATION and that can influence the conformity of the EM EQUIPMENT:

Coaxial cable for antenna connection. The cable length must be less than 3m.

The installing of the feelers/applicators is simple and intuitive: it is necessary to connect the two ends of the coaxial cable to the connector located respectively in the side panel of the machine and the antenna to be used, taking care to properly tighten the ring nut of the connectors.

Contact authorised dealers EME srl for problems or difficulty installation.

## CONNECTIONS

The power entry module can be found on the back of the unit and consists of a three-pole socket for the cable set, an extractible fuse box with two fuses (see technical specifications) and the main switch.

Plug the power supply cable three-pin plug into the integrated board and ensure that it is correctly plugged into the connector.

When using an extension lead, make sure that it has been earthed.

Failure to comply with the above instructions may lead to dangerous electrical discharge causing machine damage and harm to persons.

Once you have checked that installation and assembly have been carried out according to instructions provided up to this point in the manual, switch on the machine making sure that the display screen is turned on correctly.

## DESCRIPTION OF THE EQUIPMENT

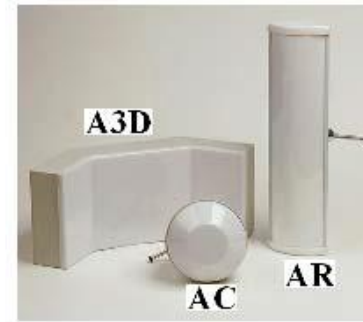

**Antenna three-dimensional (A3D model)** for applications in the shoulder, neck, spine.

**Antenna rectangular (AR model)** for applications on large areas like arms and legs, cervical brachialgie, spine.

**Circular antenna (AC model)** for use on joints, neck, hands, feet.

Application Techniques: pulsed (radiate with a sequence of actions and pauses operating with a constant period of about 1 second) continuous operation.

The pulsed operation allows to operate with a relatively long time (where necessary) without causing patient discomfort due to excessive application of heat.

### PROGRAMMING PANEL

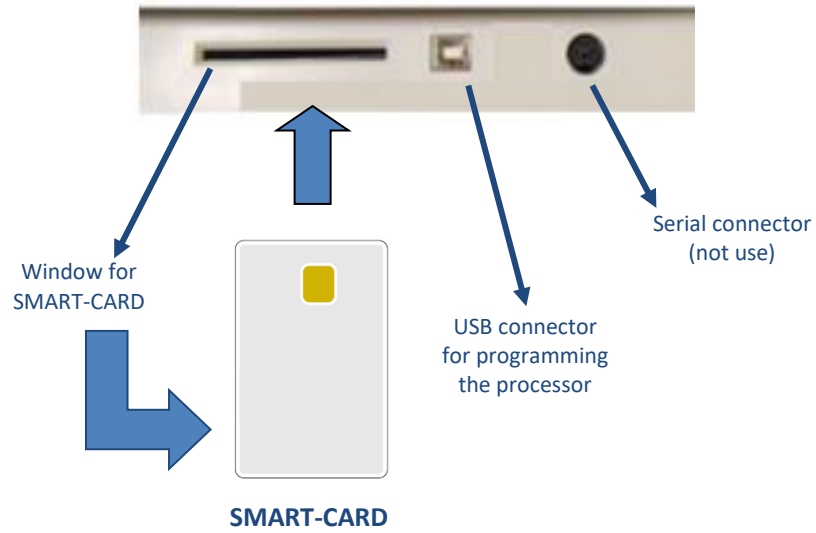

### POWER SUPPLY BOARD

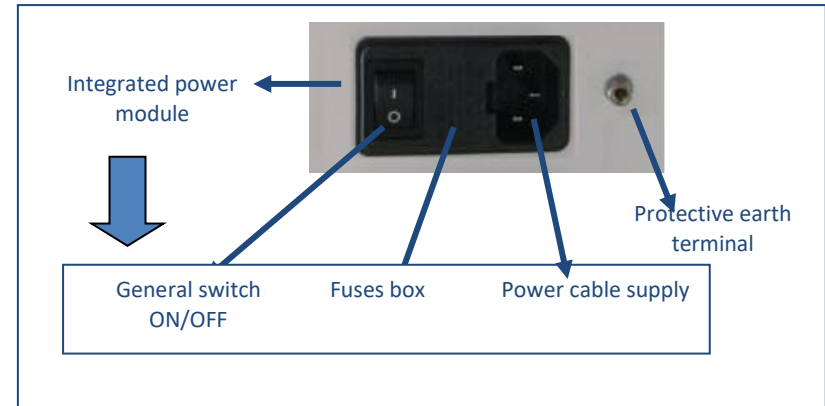

## HOW TO USE OF THE DEVICE

This section provides important information and instructions on how to make the best use of the equipment for radar-therapy RADARMED 2500 CP.

All the control functions and the machine itself are handled and co-ordinated by a microprocessor: apart from making pre-memorised programmes available for application, the microprocessor ensures that the machine can be personalised and operated in a highly safe and efficient manner.

Interfacing allows for the operator to communicate with the unit by means of a large, clear graphic backlit liquid crystal display screen (LCD) through which all operational messages required by the operator, work status during operation, and errors are visualised.

In the following chapters we describe all the operations that the operator must carry out to make the best use of the potential and the technical specifications of this device.

The following paragraphs illustrate the procedures to be carried out and the technical specifications of the RADARMED 2500 CP unit. They also deal with the different options available, from the selection of a pre-memorised programme for use in specific treatments as well as how to determine the correct working parameters for “personalised” applications.

### BEST USE

After having installed and correctly positioned the machine as per the instructions described in the previous sections and once the antenna cable has been attached to the correct connector, plug the power plug into the mains socket (230 Vac) and turn on the equipment by switching the ON/OFF switch on the back panel to “ON”.

Once turned on, the LCD display lights up and the unit is ready for use.

With the first turn on the device, you can set the language between the six available. Then turn the encoder to select the desired language and press the knob to confirm the selection. Press the SAVE button to save the changes. A confirmation message will inform you of any such modification.

After a few moments to load the settings, the LCD display will light up showing the logo (see Fig.1), and appears a screen that allows you to select between four operating modes (Fig.2) by tapping the corresponding button on the screen.



Fig.1

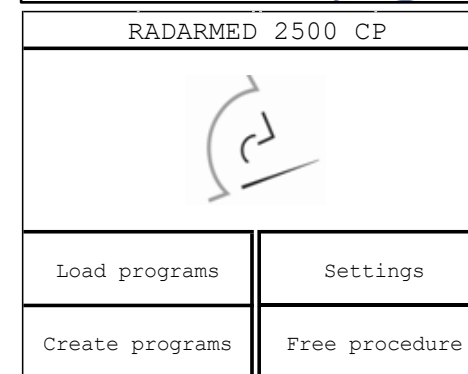

Fig.2

If you want to use the Smart-Card to create new customised programmes or to run those already stored, insert it as shown in the Fig.3, with the chip facing upward.

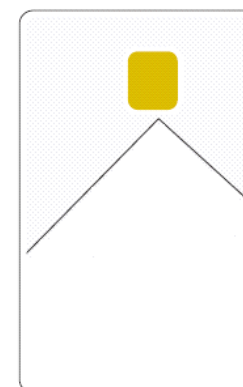

Fig.3 – SMART-CARD

## SETTINGS

The basic settings can be modified and stored in the internal memory and will be called automatically when the unit is switched on.

Pressing the button for the function SETTINGS appears the screen of the fig.4.

Turning the encoder (by the default this is located on the menu VARIOUS) you select the function that you want to change, then pressing this knob confirms the choice.

The screen displays also the version of the software installed on the equipment and contacts of the company.

Pressing the button EXIT, to return to the screen of the fig.2.

## VARIOUS

In this section, it's possible to customize or turn off the acoustic signal to suit operator preferences.

In the screen of fig.4, , rotates the encoder knob to select VARIOUS section. Then press this knob to confirm the choice. Appears the screen of fig.5.

Pressing the encoder knob on the BUZZER menu, it's possible to turn on or to turn off the acoustic signal. When there is a check the acoustic signal is working.

Pressing the SAVE button, stores the desired sound settings. Instead, pressing the EXIT taste will cancel the operation. In both cases, it returns to the screen in fig.4.

In the section VARIOUS you can also format the smart-card and the user memory.

All new cards that have never been previously used must be formatted. You can also use the FORMAT SMART-CARD function to delete it completely. If you do this it can be used on a different unit.

Select one of the memory supports to format turning to the right the encoder knob, and press this knob to confirm the choice.

In order to avoid accidental deletion, you are asked to confirm the operation (see fig.6).

Pressing the FORMAT button, the formatting operation of the selected support memory is executed. When formatting is completed, a screen will appear showing that the operation is completed (see fig.7). After some seconds the main page of this section will appear again.

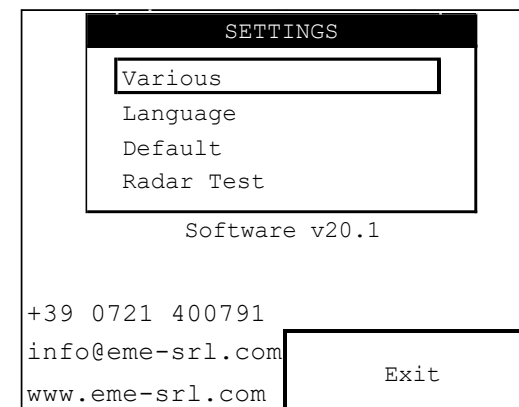

Fig.4

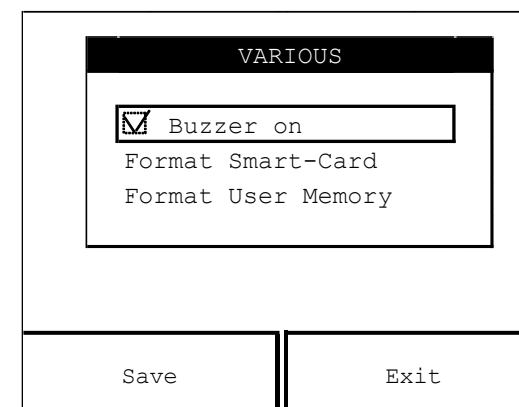

Fig.5

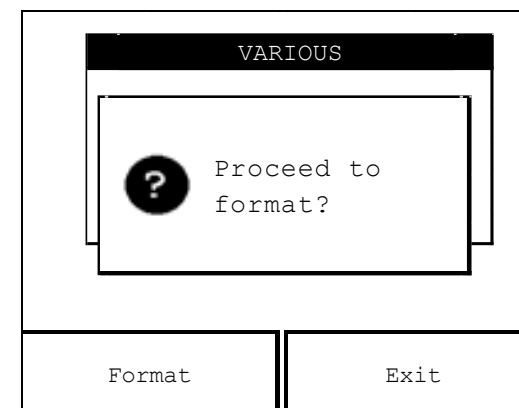

Fig.6

If you proceed with the formatting of Smart-Card but this support is not entered, the operator is informed by an error message.

Pressing the EXIT button to cancel the format operation of the selected memory support and returns to the screen in fig.5.

Pressing again the EXIT button to return to the screen in fig.4.

## LANGUAGE

To choice the language in which you wish to have all the commands and messages, rotate the encoder knob then press this knob at the LANGUAGE menu (see fig.4).

For to choose the desired language, rotate the encoder knob until to reach the correspondent language, then push this knob for to confirm the choice.

Finally, press the SAVE button for to train the device to work with the selected language. Otherwise, press the EXIT button to cancel the operation. In both cases, it returns to the screen in fig.4.

Pressing the EXIT button to return to the screen in fig.2.

After a short wait for the loading of the new dictionary, you will see the menu with the new language. To change the language back, you can repeat this procedure at any time.

## DEFAULT

Allows to set the parameters of a standard therapy, most commonly used, that can be immediately used with the FREE PROCEDURE function.

On the screen of fig.4 turn and then press the encoder knob at the DEFAULT menu to enter in this section.

Appears the screen of fig.8 where it's possible to set the default program of the device intervening on duration, power, and duty-cycle as parameters; selecting them by the rotation of the encoder knob and then pressing this knob to highlight the selected parameter.

Then turn again the knob (in clockwise way for increasing values, in counter-clockwise way for decreasing value) until to reach the desired value to assign at the selected parameters and push again the encoder knob to exit the modification procedure.

Pressing the button for the function SAVE, you return to the screen of the fig.4.

Otherwise pressing the EXIT button, you return to the screen of fig.4 without that is applied any modification.

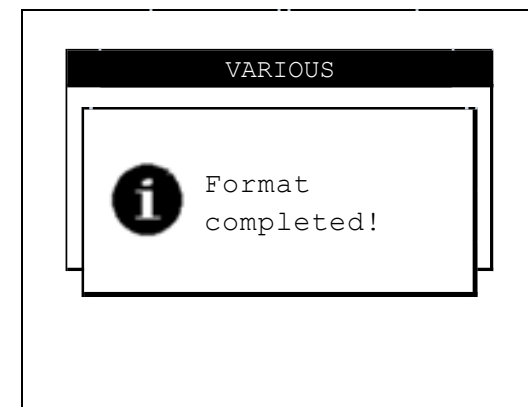

Fig.7

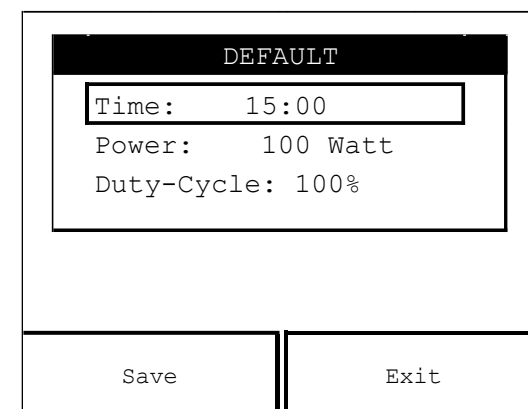

Fig.8

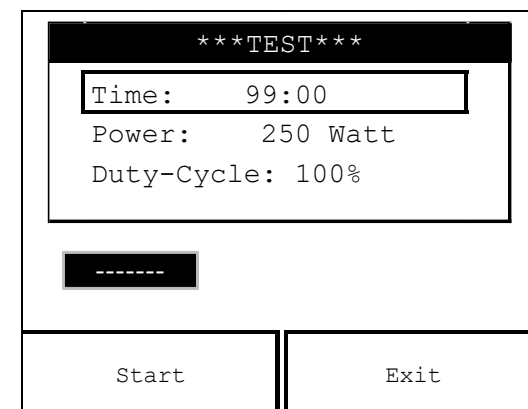

Fig.9

## TEST RADAR

This test verifies the function of the Magnetron (microwave generator), showing the power current in relation to the power issued.

On the screen of fig.4 turn and then press the encoder knob at the TEST RADAR menu to enter in this section.

The screen in fig.9 appears, where you can modify only the values of power and duty-cycle: selecting them by the rotation of the encoder knob and then pressing this knob to highlight the selected parameter.

Then turn again the knob (in clockwise way for increasing values, in counter-clockwise way for decreasing value) until to reach the desired value to assign at the selected parameters and push again the encoder knob to exit the modification procedure.

When you have modified all needed parameters, press the button START to start the test, the screen in Fig.10 will appear.

After you pressed the button START you can still modify the power and the pulse percentage, and thus verify that the current varies accordingly.

Press the button PAUSE to pause the emission, you can then resume it by pressing again the button START (see Fig.11); instead if you press the button STOP, the test will be interrupted and the screen in Fig.9 will appear again.

If you press the button EXIT, you will get back to the screen in Fig.4.

## FREE PROCEDURE

Allows you to create customized programs that can be used immediately but not stored.

Pressing the FREE PROCEDURE taste (fig.2), appears the screen of the fig.12.

Before starting treatment, you can change the parameters of treatment, select them rotating the encoder knob and then pressing it on the selected parameter. Then turn again the knob to modify the parameter value and push again the encoder knob to exit the modification procedure

During their modification, parameters are marked in black. You cannot modify other parameters or exit the modification procedure until you confirm selection by pressing the encoder knob or waiting some seconds until marking disappears.

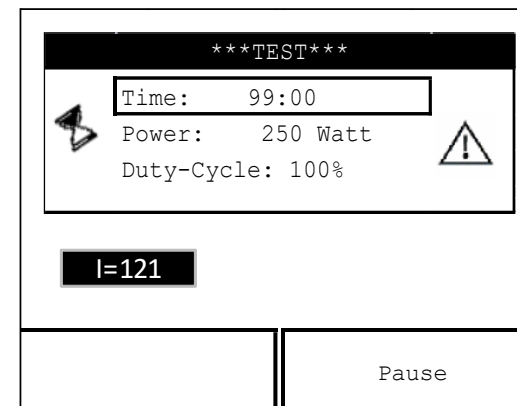

Fig.10

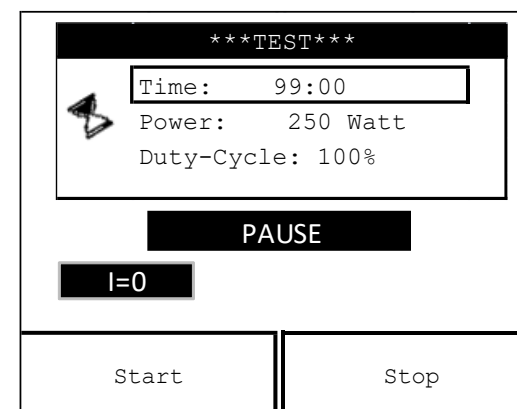

Fig.11

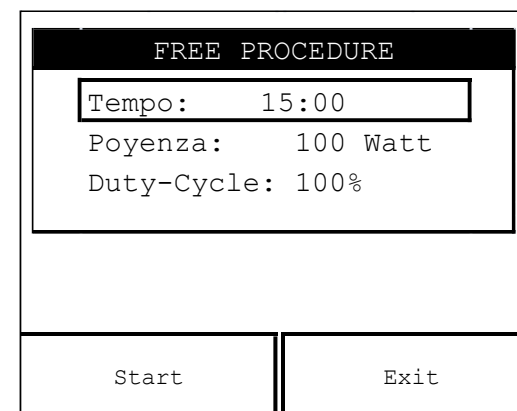

Fig.12

**N.B.:** By duty-cycle (**working cycle or effective working cycle**) we mean the fraction of real time during which an entity turns into an active state in relation to the determined total time.

To start the treatment press the START button: the countdown initiate and the hourglass moves to indicate the flowing time.

By pushing the button PAUSE emission is suspended and a PAUSE message appears on the screen.

Pressing the START button the emission resumes from where it left off and continues until the timer expires. At the end the system alerts the operator via a message on the screen that the treatment is over and you return to the screen in fig.12.

If you press the STOP button the emission finally ends and you return to the screen in fig.12. Pressing the EXIT button returns you to the screen in fig.2.

## LOADING PROGRAMS

Pressing the LOAD PROGRAM button on the screen (see fig.2), appears the list of therapeutic protocols stored in the main memory (as shown by the frame around the STANDARD PROGRAMS button which is selected by default). These programs cannot be deleted but can be overwritten by changing the parameters of interest without saving.

Instead pressing the USER PROGRAMS button, appear on the screen the numbered sections (with default parameters) that will contain the programs created with the CREATE PROGRAMS function, and you can load programs stored in the user memory.

Finally pressing the SMART-CARD PROGRAMS taste, appear on the screen the numbered sections (with default parameters) that will contain the programs created with the CREATE PROGRAMS function, and you can load customized programs, stored in the smart-card.

**NOTE:** If you save a program on Smart-Card but the Smart-Card is not inserted, the operator is alerted by an alarm message to the not inclusion of the Smart Card into place and then the inability to be able to continue in the operation of storage programs.

The stored programmes reflect the fruit of many years experience supporting expert professional operators. Appendix C shows a list of the programmes available .

Pressing the EXIT button (whatever the memory selected) returns to the screen of the fig.2.

To start the desired treatment, turn the encoder knob to reach the desired protocol, then press it to confirm the selection.

Once the display shows the selected program screen, you can go directly to its execution by simply pressing the START button.

Before initiation of therapy, however, you can modify any parameter, as discussed in FREE PROCEDURE, but the program can neither be stored nor renamed.

## CREATE PROGRAMS

This function allows to store “customized” therapeutic programs in the Smart-card or in the user memory, which are the only memory available to save the new programs.

Pressing the CREATE PROGRAMS taste on the screen (see fig.2) to create a program; appears the screen of the fig.13.

Pressing the encoder knob, you can start by default the creation of the program on the user memory (as shown by the frame around the USER PROGRAM button).

Instead, press the SMART-CARD PROGRAMS button to create a program on the smart-card.

**NOTE:** If you save a program on Smart-Card but the Smart-Card is not inserted, the operator is alerted by an alarm message (see fig.14) to the not inclusion of the Smart Card into place and then the inability to be able to continue in the operation of storage programs.

Once you select the support of memory in which to save the program, press the encoder knob to confirm the selection. It appears the screen of the figure 15.

At this screen, to assign a name to the program press the encoder knob: appears a cursor under the first character (see Figure 16), indicating the possibility to switch between the characters that you want to change by turning the knob. Then press the encoder knob at the character to confirm your choice.

Now the selected character is surrounded by two sliders (fig. 17), which means that the character is changed. Rotating the encoder to choose a new character to enter and press the encoder knob to confirm the selection. This exits from the routine to change the selected character.

Repeat the procedure for all the characters that you want to change, then press the OK button to confirm the new name to be entered. You return to the screen of the fig.15, where, however, the program now has a new name.

Before making the save, you can change the parameters of treatment, as described above in the FREE PROCEDURE menu.

Press the button corresponding to the SAVE button to confirm saving the custom program with the new name on the storage support initially selected. The operator will be notified of the rescue, then the screen will appear in fig.18.

After a few moments it returns to the screen in fig.13. Press the EXIT button to return to the fig.2.

## MAINTENANCE

The RADARMED 2500 CP device for radartherapy do not require any particular maintenance operations , but only a periodic maintenance and cleanliness of the probes, in order to ensure the better operating conditions, guarantee the effectiveness of the treatment and the safety of the patient. A special intervention is not required in the event of failure of the medical device, but just a normal maintenance / repair.

When cleaning the outer part of the equipment, make sure to use a soft, clean cloth dampened with luke-warm water or very mild non inflammable detergents. The front panel can be cleaned in the same way .

The applicators periodically should be cleaned with water and denatured alcohol. Store with care the applicators at the conclusion of every treatment

Contact authorised dealers of EME srl for information regarding original spare parts or components.

Do not spray or pour liquid onto the external parts of the equipment and onto the probes.

Do not immerse the unit in water.

After cleaning the external part of the equipment, make sure to dry it perfectly before turning on the unit.

The unit must under no circumstances be opened or dismantled in order to clean or check inner parts of equipment does not require cleaning of inner parts and in all cases, only specialised technicians or EME srl authorised personnel should carry out such operations.

The expected work life of device is 10 years.

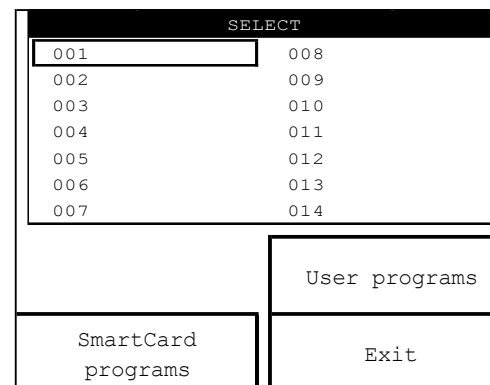

Fig.13

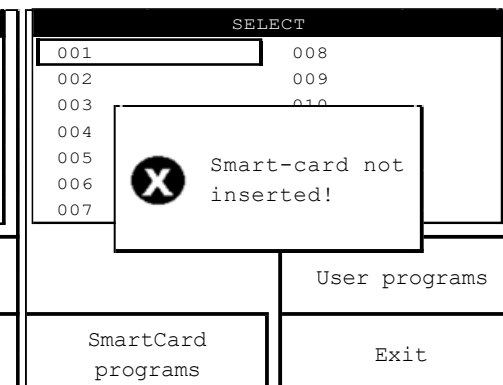

Fig.14

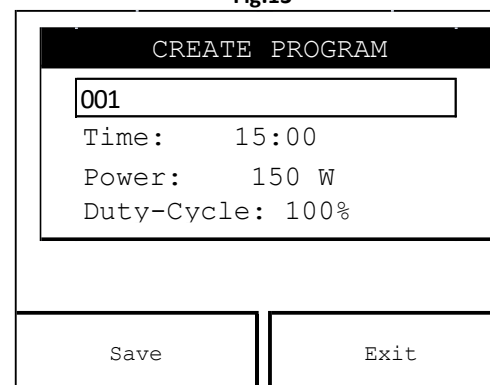

Fig.15

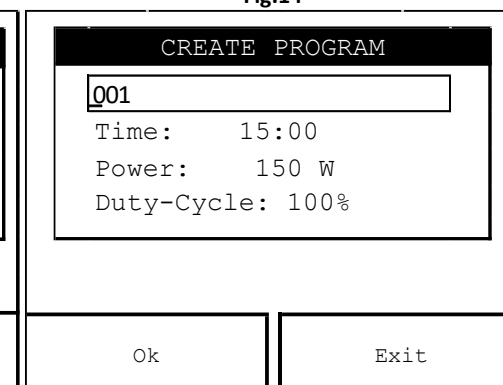

Fig.16

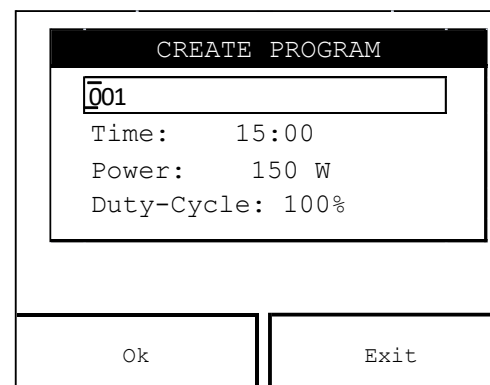

Fig.17

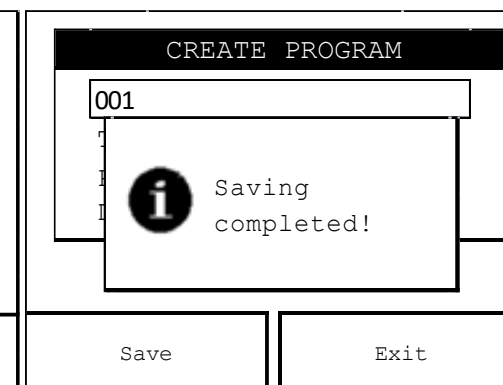

Fig.18

## TECHNICAL PROBLEMS

The equipment for radar-therapy RADARMED 2500 CP has been designed and manufactured using highly advanced technology and first class components for reliable and efficient performance.

However, should you meet with any operational problems, we recommended that you consult the following guide before contacting any of our authorised service centres.

If any of the following situations occur, disconnect the machine and contact EME srl authorised service centres:

- the cable set or rear supply panel show signs of wear and tear or are damaged;
- the liquid has entered the equipment
- the equipment has been exposed to rain.

## ELECTROMAGNETIC INTERFERENCES

The equipment for radar-therapy RADARMED 2500 CP has been designed and manufactured according to the ELECTROMAGNETIC COMPATIBILITY DIRECTIVE 2014/30/UE with the aim of providing adequate protection from harmful interference when installed in homes and health establishments.

All required measurements and tests have been carried out in EME's internal Testing, Measurement and Inspection laboratory (LPMC), in addition to other external specialised institutes. The customer, upon prior request, may view the reports relative to EMC measures within the company.

The equipment does not generate significant radio frequency energy and is adequately immune to radiated electromagnetic fields. Therefore it does not detrimentally interfere with radio-electric communications, electro-medical equipment for monitoring, diagnosis, therapy and surgery, office electronic devices such as computers, printers, photocopiers, fax machines, etc. or any electric or electronic equipment used in these environments, as long as said equipment complies with the ELECTROMAGNETIC COMPATIBILITY directive .

In any case, in order to avoid any interference problems, we recommend that you operate the therapy equipment far enough away from critical equipment for monitoring vital patient functions, and that you be careful when applying therapy to patients with pacemakers.

## TROUBLESHOOTING CHART

| PROBLEM   | POSSIBLE CAUSE  | SOLUTION  |
|---|---|---|
| Front panel LCD display doesn't come on..   | Plug incorrectly inserted into socket.  | Check that the socket is working correctly.   |
|   | Faulty components in the electronic control card.   | Contact EME srl Service centre.   |
| The unit does not work.   | Handle cable interrupted or wrongly connected   | Insert plug and cable completely into the unit connector.   |
|   | Cable is worn, damaged or blocked.  | Replace the worn out or damaged power cable   |
|   | The switch on the rear of the unit is turned off.   | Turn on the switch  |
|   | Fuses missing, blown or blocked.  | Replace any missing, blown or interrupted fuses   |
|   | Electronic control circuit does not work  | Contact EME srl Service centre  |
| Some of the buttons on the front control panel do not function correctly.   | No power reaching the socket.   | Contact EME srl Service centre  |
|   | Faulty keys or buttons  | Contact EME srl Service centre  |
| The device turns on, but there is no radiofrequency energy emission.  | Electronic control circuit malfunction  | Contact EME srl Service centre  |
|   | Incorrect turning on, setting, or starting up of the equipment.                                 | Check that the equipment settings are correct.  |
|   | Possible Magnetron microwave generator device fault.  | Contact EME srl Service centre  |
| The equipment works properly, but there is a notable fall in treatment efficiency and overheating of the coaxial cable and connecting connectors between the equipment and the radiating antenna. | Failure in electronic current generator circuit.  | Contact EME srl Service centre  |
|   | Defective connection in the connecting circuit between the equipment and the radiating antenna. | Carefully check the correctness and integrity of the output connections.  |
|   | Coaxial cable blocked worn, damaged or defective.   | Check the conditions of the radiating antenna and its connections.  |
|   | Radiating antenna defective or damaged.   | Check that there aren't any metallic objects, panels or other obstacles between the radiating antenna and the patient that could absorb or disturb the electromagnetic field emitted. |
|   | Non aligned adjustment electronic circuit.  | Contact EME srl Service centre  |

## TECHNICAL FEATURES

|   |  |  |
|---|--|--|
| Main voltage  | 230 Vac 50-60 Hz $\pm 10\%$  |  |
| Max. Power absorption   | 600 VA   |  |
| Double protection fuse on power supply (T):   | 230 Vac  | 6.3 A-T 5 x 20 mm                        |
| Backlit LCD display to view and check the operating parameters                      | Graphic 320 x 240 pixel<br>Touch screen + encoder  |  |
| Programmable treatment time   | Up to 30 minutes   |  |
| Frequency emission  | 2450 MHz   |  |
| <u>Classification in compliance with the directive 93/42/CEE</u>                    | <u>II B</u>  |  |
| <u>Class of isolation/parts applied according to the rule EN 60601-1</u>            | <u>I / BF</u>  |  |
| <u>Degree of protection by the liquid access in according to the UNI EN 60601-1</u> | <u>IPX0</u>  |  |
| Functioning   | Continuous   | 100%                                     |
|   | Pulsed   | 10% ÷ 90%                                |
| Peak continuous power with adapted load 50 Ohm                                      | 250 W  |  |
| Peak pulse power with adapted load 50 Ohm   | 1600 W   |  |
| Number of protocols that can be saved in the user memory                            | 200  |  |
| Number of protocols that can be saved in the smart-card                             | 200  |  |
| Metal trolley container, external dimensions (large. x high. x depth)               | 39 x 89 x 30 cm<br>without arm and antenna,<br>65 x 172 x 31 cm<br>including arm and antenna |  |
| Weight of the device body   | 34,2 Kg without arm and antenna,<br>38,7 Kg including arm and antenna                        |  |
| Conditions for use  | <u>Room temperature</u>  | <u>(+10 ÷ +40) °C</u>                    |
|   | <u>Relative humidity</u>   | <u>(10 ÷ 80) % without condensation</u>  |
| Conditions for stocking / transport   | <u>Room temperature</u>  | <u>(-40 ÷ +70) °C</u>                    |
|   | <u>Relative humidity</u>   | <u>(10 ÷ 100) % without condensation</u> |

Atmospheric pressure

(500 ÷ 1060) hPa

## APPENDICES

### Appendix A - ENVIRONMENTAL CONSIDERATIONS

RADARMED 2500 CP equipment for radartherapy has been designed and manufactured to have minimal negative environmental impact, in line with its operational and safety requirements.

Rigorous standards were followed in order to minimise the amount of waste, use of toxic materials, noise, non-required radiation and energy consumption.

In accordance with careful research, the unit has been designed to optimise power consumption in keeping with energy saving principles.



This symbol means that the product should not be disposed of as domestic waste.

The user must dispose of scrap equipment by taking it to a recognised electrical and electronic recycling centre.

### Appendix B- LABEL

| Symbol  | Mean   |
|---------|--|
| CE 0476 | This product complies with regulations issued under the certification from a Notified Body |
|         | Applied part BF  |
|         | Manufacturer   |
|         | Date of manufacture  |
|         | Consult instructions for use   |
|         | Attention  |
|         | The product must be disposed of as "electronic waste", not as "domestic waste"             |
|         | input characteristics  |

| Symbol | Mean                                       |
|--------|--|
|        | Input voltage to the device (mains)        |
|        | Fuses: 2xT6.3AL250V                        |
|        | Input power of the device (absorbed power) |
|        | Input frequency of the device              |
|        | Device model                               |
|        | Serial number                              |
|        | Output characteristics of the device       |
|        | Output power supply                        |
|        | Output frequency of the device             |
|        | Duty-Cycle step                            |
|        | Temperature range                          |
|        | Atmospheric pressure range                 |
|        | Humidity range                             |

| Symbol | Mean   |
|--------|--|
|        | Label indicating mandatory reading of instructions, located on the front panel of the device or near the output connectors |
|        | Label indicating sensitive equipment to electrostatic discharge, located near the connector for serial connection          |
|        | "non ionised radiation" label placed near the output cable connector for the microwaves.                                   |
|        | "Prohibited push" to apply behind the basket at the top of the center.   |



## Appendix C - INSTRUCTIONS FOR THE CONNECTION OF FEELER CABLE TO THE MAGNETRON

**NOTE:** A basic requirement for the proper functioning of the RT 250 DIGITAL equipment is that the antenna cable is properly connected and carefully checked before using it.

Incorrect assembly:

- reduces the transfer of power to the antenna,
- causes overheating of the cable and the connectors,
- can irreparably damage the Magnetron microwave generator.

### INSTALLING PROCEDURE:

|          |   |
|----------|---|
| <b>1</b> |  <p>Connection to the connector on the housing:</p> <ul style="list-style-type: none"> <li>○ fully insert the connector without screwing it in,</li> <li>○ screw (in a clockwise direction) the ring nut by hand as tightly as possible, tighten the ring nut by hand as much as possible.</li> </ul>  |
| <b>2</b> |  <p>Connection to the connector on the antenna:</p> <ul style="list-style-type: none"> <li>○ fully insert the connector without screwing it in,</li> <li>○ screw (in a clockwise direction) the ring nut by hand as tightly as possible, tighten the ring nut by hand as much as possible.</li> </ul> |

In both cases it should not now be possible to turn the connector body by hands.

## Appendix D – LIST OF THERAPEUTIC SUGGESTIONS

| List of therapeutic treatments | Time (min) | Power (Watt) | Pulse (%) | Type of feeler recommended |
|--------------------------------|------------|--------------|-----------|----------------------------|
| Knee osteoarthritis            | 30         | 50           | 100       | AC                         |
| Rotator cuff tendinopathy      | 30         | 40           | 100       | AC                         |
| Low back pain                  | 15         | 100          | 100       | A3D                        |
| Passive muscle warming *       | 8          | 100          | 100       | AI                         |
| Preparation for massage *      | 10         | 100          | 100       | AI                         |
| Muscle stiffness               | 10         | 110          | 80        | AI                         |
| Cervical myofascial syndrome   | 10         | 75           | 50        | AI                         |
| Carpal tunnel syndrome         | 15         | 32           | 100       | AC                         |

**\*Treatment not covered by medical CE.**

**NOTE:** The intensity of the energy supplied to the tissue depends on the type of radiator, therefore each treatment should be used with the recommended antenna. The abbreviations are as follows:

AC = Antenna Circular

AR = Antenna Rectangular

A3D = Antenna Three-dimensional

I = Indifferent

## Appendix E – ELECTRO-MAGNETIC COMPATIBILITY TABLES

| Guidance and manufacturer's declaration – electromagnetic emissions   |            |  |
|---|------------|--|
| The ME EQUIPMENT is intended for use in the electromagnetic environment specified below. The customer or the user of the ME EQUIPMENT should assure that it is used in such an environment. |            |  |
| Emissions test  | Compliance | Electromagnetic environment – guidance   |
| RF Emissions<br>CISPR 11  | Group 2    | The ME EQUIPMENT must emit electromagnetic energy in order to perform its intended function. Nearby electronic equipment may be affected.  |
| RF Emissions<br>CISPR 11  | Class A    | The ME EQUIPMENT is suitable for use in all establishments different from domestic establishments and those directly connected to the public low voltage power supply network that supplies buildings used for domestic purposes |
| Harmonic emissions<br>IEC 61000-3-2   | Class A    |  |
| Voltage fluctuations/<br>flicker emissions<br>IEC 61000-3-3   | Complies   |  |

| 13.4.1 Guidance and manufacturer's declaration – electromagnetic immunity   |                                  |   |  |
|---|----------------------------------|---|--|
| The ME EQUIPMENT is intended for use in the electromagnetic environment specified below. The customer or the user of the ME EQUIPMENT should assure that it is used in such an environment. |                                  |   |  |
| Immunity test   | IEC 60601 Test level             | Compliance level  | Electromagnetic environment –guidance  |
| Electrostatic discharge (ESD)<br>IEC 61000-4-2  | ± 8kV contact                    | ± 8kV contact   | Floors should be wood, concrete or ceramic tile. If floors are covered with synthetic material, the relative humidity should be at least 30 %.   |
|   | ± 2; 4; 8; 15 kV air             | ± 2; 4; 8; 15 kV air  |  |
| Electrical fast transient/burst<br>IEC 61000-4-4  | ± 2kV per power supply lines     | ± 2kV per power supply lines  | Mains power quality should be that of a typical commercial or hospital environment   |
|   | ± 1kV for input / output lines   | ± 1kV for input / output lines  |  |
| Surge<br>IEC 61000-4-5  | ± 1kV line(s) to line(s)         | ± 1kV line(s) to line(s)  | Mains power quality should be that of a typical commercial or hospital environment   |
|   | ± 2kV line(s) to earth           | ± 2kV line(s) to earth  |  |
| Voltage dips, short interruptions and voltage variations on power supply input lines<br>IEC 61000-4-11  | 0% U <sub>T</sub> for 0,5 cycles | 0% U <sub>T</sub> for 0,5 cycles  | Mains power quality should be that of a typical commercial or hospital environment. If the user of the ME EQUIPMENT requires continued operation during power mains interruptions, it is recommended that the ME EQUIPMENT be powered from an uninterruptible power supply or a battery. |
|   | 0% U <sub>T</sub> for 1 cycles   | 0% U <sub>T</sub> for 1 cycles  |  |
|   | 70% U <sub>T</sub> for 25 cycles | 70% U <sub>T</sub> for 25 cycles  |  |
|   | 0% U <sub>T</sub> for 250 cycles | 0% U <sub>T</sub> for 250 cycles  |  |
| Power frequency (50/60Hz) magnetic field<br>IEC 61000-4-8   | 30 A / m                         | Not applicable, the device does not contain components susceptible to magnetic fields | Power frequency magnetic fields should be at levels characteristic of a typical location in a typical commercial or hospital environment   |
| NOTE : UT is the a.c. mains voltage prior to application of the test level.   |                                  |   |  |

| <b>Guide and declaration of the manufacturer - electromagnetic immunity</b>   |   |                     |   |
|---|---|---------------------|---|
| The ME EQUIPMENT is designed to work in the electromagnetic environment specified below. The client or user of the ME EQUIPMENT should ensure that it is used in this environment<br>Portable and mobile RF communications equipment should not be used closer to any part of, including cables, than the recommended separation distance calculated with the equation applicable to the transmitter frequency. |   |                     |   |
| Immunity test   | Trial level of the IEC 60601  | Level of compliance | <b>Recommended separation distance d:</b> |
| Conducted RF<br>IEC 61000-4-6   | 3 Veff<br>from 150kHz to 80 MHz                                       | 3 Veff              | <b>d= 30 cm</b>                           |
| Radiated RF<br>IEC 61000-4-3  | 3 V/m<br>from 80 MHz to 2,7 GHz                                       | 3 V/m               | <b>d= 30 cm</b>                           |
| Immunity to proximity fields from wireless RF communication devices<br>IEC 61000-4-3  | TETRA 400<br>380 – 390 MHz  | 27 V/m              | 27 V/m                                    |
|   | GMRS 460<br>FRS 460<br>430 – 170 MHz                                  | 28 V/m              | 28 V/m                                    |
|   | LTE Band 13, 17<br>704 – 787 MHz                                      | 9 V/m               | 9 V/m                                     |
|   | GSM 800/900, TETRA 800, iDEN 820, CDMA 850, LTE Band 5 800 960 MHz    | 28 V/m              | 28 V/m                                    |
|   | GSM 1800; CDMA 1900; GSM 1900; DECT; LTE Band 5 1700 – 1990 MHz       | 28 V/m              | 28 V/m                                    |
|   | Bluetooth, WLAN, 802.11 b/g/n, RIFD 2450, LTE Band 70 2400 – 2570 MHz | 28 V/m              | 28 V/m                                    |
|   | WLAN 802.11 a/n 5100 – 5800 MHz                                       | 9 V/m               | 9 V/m                                     |
|   |   |                     | <b>d= 30 cm</b>                           |

DICHIARAZIONE DI  
CONFORMITÀ ALLA  
DIRETTIVA 93/42/CEE  
SUI DISPOSITIVI MEDICI

**EMME**  
ITALY

Aesthetic & Medical Technologies

DECLARATION OF  
CONFORMITY TO THE  
93/42/CEE DIRECTIVE  
ON MEDICAL DEVICES

**Il Fabbricante / The manufacturer**

**EMME Srl - Via degli Abeti, 88 / 1 - 61122 PESARO (PU) - ITALY**

**dichiara sulla sua responsabilità che il prodotto :  
declares on its own responsibility that the product :**

Apparecchiature per radar terapia /  
Equipment for radar therapy :

**RADARMED 2500 CP**

è conforme alle prescrizioni della direttiva comunitaria 93/42/CEE e successive integrazioni e modifiche  
(Allegato II eccetto il punto 4), recepita in Italia con  
D.L. N° 46 del 24 febbraio 1997 e successive integrazioni e modifiche ,  
e la classe di rischio è la IIb secondo la regola 9.

*is in compliance with the 93/42/CEE Directive and the following integrations and modifications  
(Annex II except point 4 ), implemented in Italy  
following the D.L. N° 46 directive issued on 24 february 1997,  
and the risk class is IIb according to the rule 9.*

**Certificato n. MED – 31009 / Certificate n. MED – 31009**

La macchina è marcata / The equipment is marked :

**CE**  
**0476**

Organismo Notificato / Notified Body  
Kiwa Cernmet Italia S.p.a.

Pesaro, 14/04/2016

EMME srl

L' Amministratore unico / Administrator



# EME

ITALY



Italian manufacturer of physiotherapy equipment since 1983

## **EME Srl**

Via degli Abeti 88/1, Pesaro (PU) 61122 ITALY

T +39 0721400791 - F +39 072126385 - [info@eme-srl.com](mailto:info@eme-srl.com) - [www.eme-srl.com](http://www.eme-srl.com)