

StarBoard

INTERACTIVE FLAT PANEL DISPLAY YL5X PRO



Android 13



Google EDLA Certified

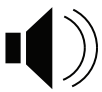

20Wx2 speakers
+ 20W Subwoofer
HIFI acoustics



Acoustics



Compatibility Windows

Mac OS & Linux

Proven Touch Screen Technology

Experience the power of proven touchscreen technology with the StarBoard IIFPD. Choose between multi-finger touch, stylus pen, or pointer response for seamless writing, drawing, and navigation.

Software

Equipped with StarBoard's Interactive Software, SBS Note, StarBoard Online, StarClass Management. Effortlessly manage content, collaborate, and create an engaging learning or working environment.

Informative, Functional, Intuitive

With advanced touch technology, The StarBoard Interactive Flat Panel Display provides the latest infrared touch technology and with all the features you expect to meet the demands of active presentations and training environments. Minimalist design with essential connectivity, front speakers, and IR technology makes it easy and intuitive to use. The large interactive surface offers a high-resolution image and delivers an excellent platform for your classroom to learn with creativity.

INTERACTIVE FLAT PANEL DISPLAY YL5X PRO

MODEL	YL5X PRO
Display Sizes	65" 75" 86"
Resolution	3840x2160 @60Hz
Active area (mm)	65": 1428.4x803.5 (64.53") 75": 1650.2x928.3 (74.52") 86": 1895.04x1065.9 (85.56")
Panel	IPS Panel (TN, TFT, VA opt.)
Glass	4mm tempered glass 7 on Mohs scale Anti-glare coating Anti-bacterial coating (opt.)
View angle	178°
Aspect Ratio	16:9
Brightness	450 cd/m2
Contrast	5000:1
Colors	10 Bit (1.07 Billion)
Resolutions supported	1024x768 / 1280x720 / 1280x960 1280x1024 / 1360x768 / 1440x900 1600x1200 / 1920x1080 / 3840x2160
Response time	< 5 ms
WiFi	6 (IEEE 802.11ax)
Bluetooth	5.2
Software included	SBS Note, SB Software, StarBoard Online, iMagic, EShare (opt.)
NFC reader	1

Input/Output connections

	Back input	Front input	Back output
HDMI 2.0	2	1	1
VGA	1		
USB-C	1	1 (65W)	
DP	1		
MIC	1		
USB 3.0	2	3	
TOUCH-USB	2	1	
RS232	1		
TF (microSD card)	1		
PC AUDIO	1		
EARPHONE			1
RJ45	1		1
OPS PORT	1		
USB 2.0	1		
COAXIAL/SPDIF			1
SPDIF			1

General	
Weight (N.W)	65": 37.00 Kg 75": 50.00 Kg 86": 60.00 Kg
Weight (G.W)	65": 48.00 Kg 75": 65.00 Kg 86": 78.00 Kg
Machine dimensions	65": 1469x915x93 mm 75": 1700x1047x96.9 mm 86": 1942x1183x93.9 mm
Packaging Dimension	65": 1646x1074x240 mm 75": 1873x1204x240 mm 86": 2120x1353x240 mm
Life span	50.000 Hours
Warranty	3 years (opt. to extend)
Certificates	EDLA, CE-RoHS, EnergyStar, EcoDesign

Android specification

System	Android 13.0
GPU	G52*8
CPU	A73*4+A53*4@2.28G
RAM	16G DDR4
Flash	EMMC 256G

Touch specification

Working temp.	0°C – 40°C
Touch points	Up to 40 Points
Writing mode	Finger or pen
Touch Technology	Infrared with Zero Air Gap
Accuracy	<1 mm
Positioning Res.	4096x4096/16384 x 16384/32768x32768
Response time	<5ms
Cursor speed	>180 dot/Sec
Comm. Port	USB

Power specification

Standby	< 0.5 W
Rated consumption	65": 140W 75": 160W 86": 180W
Voltage range	AC (100-240) V-50/ 60Hz

OPS consumption is not included

65"

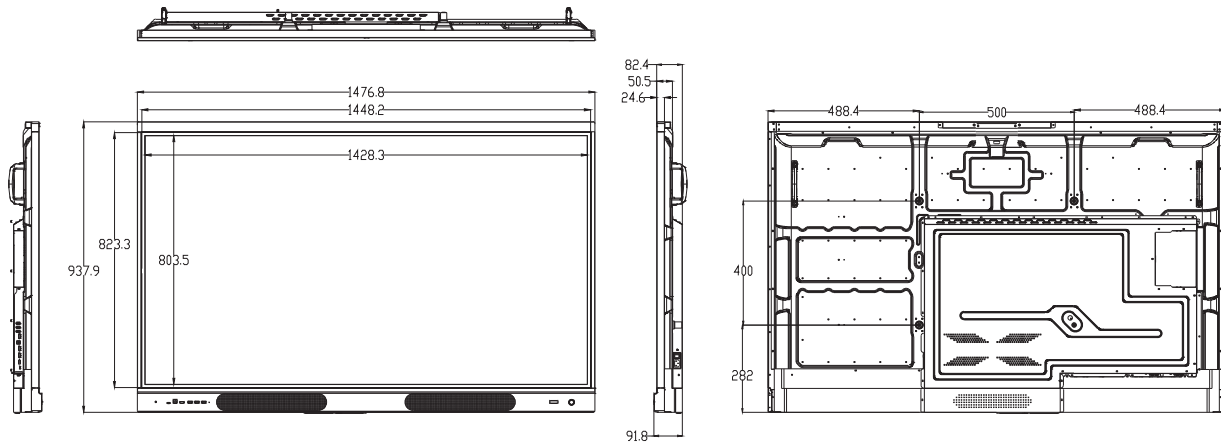

75"

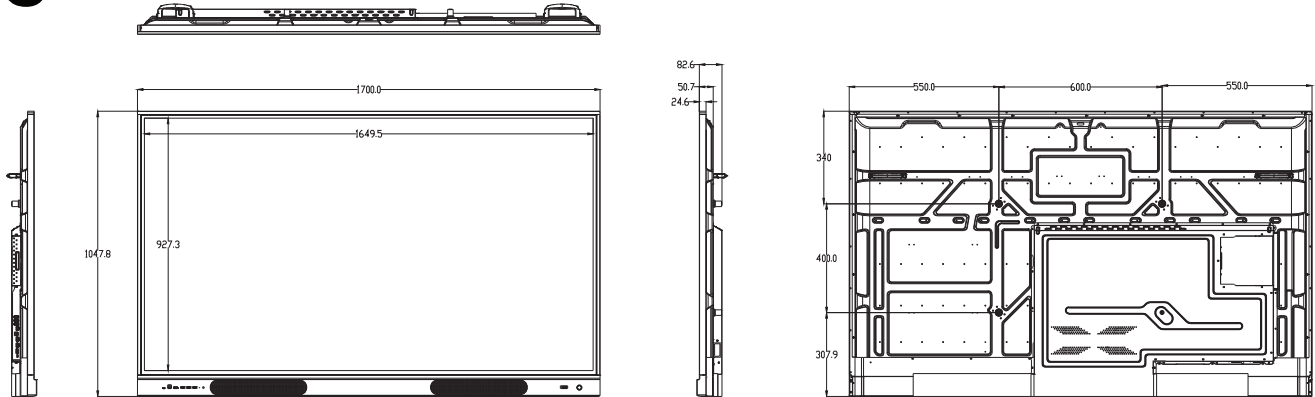

86"

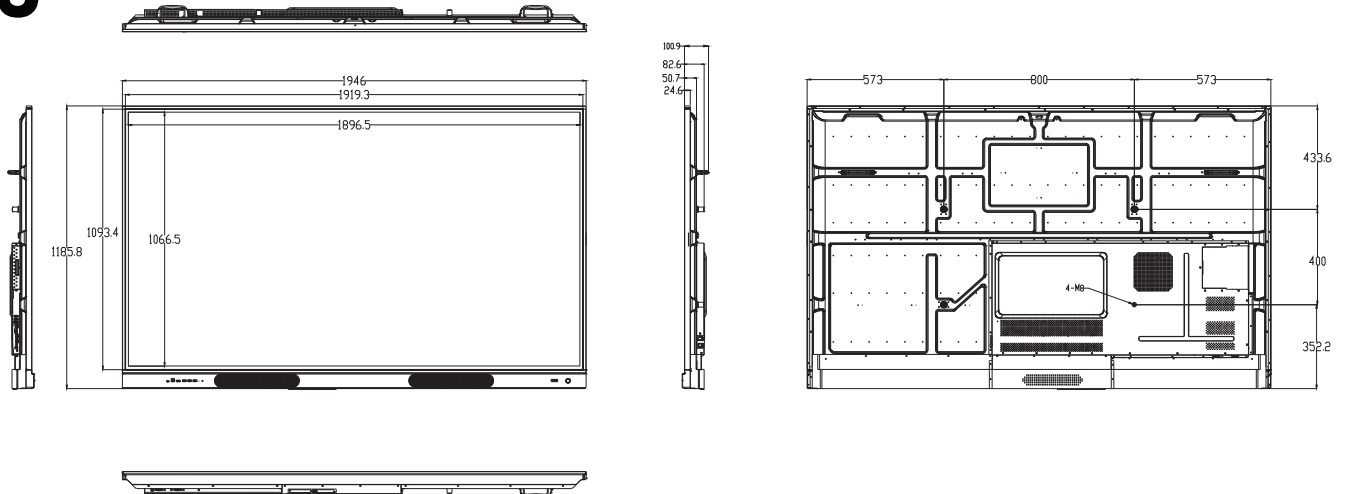

1. Accuracy of Information

We make every effort to ensure the accuracy of the information contained on our website and in our product literature. However, due to continuous product improvement and variations in manufacturing, actual product specifications and features may differ slightly from those described.

2. Changes and Updates

Product specifications, features, and availability are subject to change at any time without prior notice. We reserve the right to make changes to product designs, materials, and functionality to enhance performance and user experience.