

# OPERATIVE TECHNIQUE



**MEDGAL<sup>®</sup>**

ORTHOPAEDIC IMPLANTS & INSTRUMENTS

## Double Proximal Femoral Nail





THE FOLLOWING INSTRUCTIONS DO NOT CONSTITUTE A DETAILED OPERATING MANUAL!

THE CHOICE OF THE RIGHT SURGICAL TECHNIQUE IS THE RESPONSIBILITY OF A DOCTOR.

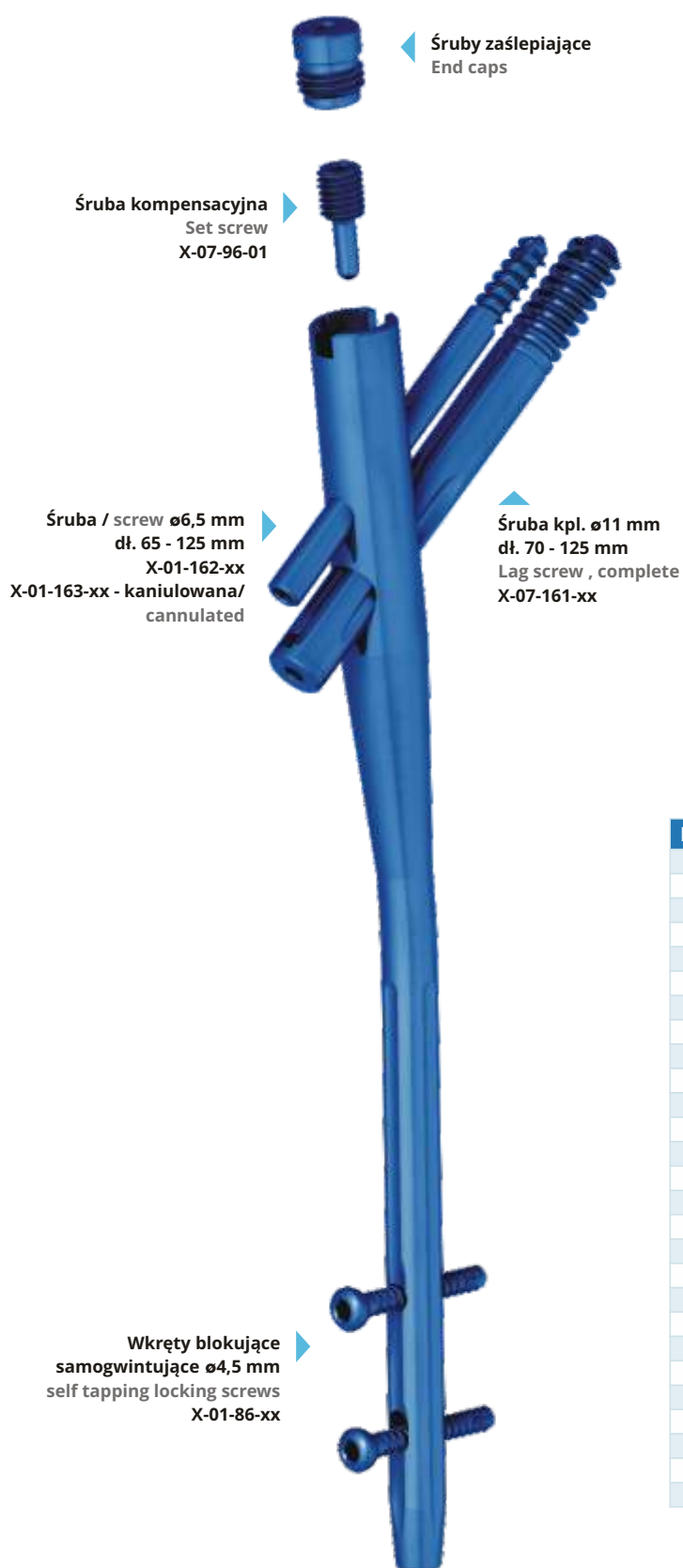

Rozmiar Size	REF
0	X-07-95-60
+5	X-07-95-61
+10	X-07-95-62
+15	X-07-95-63
+20	X-07-95-64
+25	X-07-95-65
+30	X-07-95-66

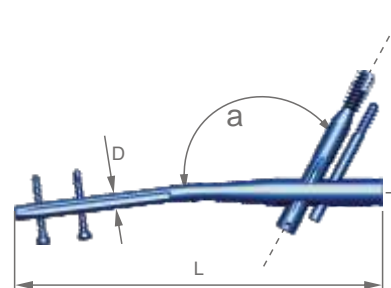

D (mm)	L (mm)	$\alpha = 125^\circ$	$\alpha = 130^\circ$	$\alpha = 135^\circ$
10	200	X-10-01-200	X-10-02-200	X-10-03-200
10	210	X-10-01-210	X-10-02-210	X-10-03-210
10	220	X-10-01-220	X-10-02-220	X-10-03-220
10	230	X-10-01-230	X-10-02-230	X-10-03-230
10	240	X-10-01-240	X-10-02-240	X-10-03-240
10	250	X-10-01-250	X-10-02-250	X-10-03-250
10	260	X-10-01-260	X-10-02-260	X-10-03-260
10	270	X-10-01-270	X-10-02-270	X-10-03-270
10	280	X-10-01-280	X-10-02-280	X-10-03-280
11	200	X-10-04-200	X-10-05-200	X-10-06-200
11	210	X-10-04-210	X-10-05-210	X-10-06-210
11	220	X-10-04-220	X-10-05-220	X-10-06-220
11	230	X-10-04-230	X-10-05-230	X-10-06-230
11	240	X-10-04-240	X-10-05-240	X-10-06-240
11	250	X-10-04-250	X-10-05-250	X-10-06-250
11	260	X-10-04-260	X-10-05-260	X-10-06-260
11	270	X-10-04-270	X-10-05-270	X-10-06-270
11	280	X-10-04-280	X-10-05-280	X-10-06-280
12	200	X-10-07-200	X-10-08-200	X-10-09-200
12	210	X-10-07-210	X-10-08-210	X-10-09-210
12	220	X-10-07-220	X-10-08-220	X-10-09-220
12	230	X-10-07-230	X-10-08-230	X-10-09-230
12	240	X-10-07-240	X-10-08-240	X-10-09-240
12	250	X-10-07-250	X-10-08-250	X-10-09-250
12	260	X-10-07-260	X-10-08-260	X-10-09-260
12	270	X-10-07-270	X-10-08-270	X-10-09-270
12	280	X-10-07-280	X-10-08-280	X-10-09-280

Gwoździe są dostępne również dla średnic / Available also for diameter D=9, 13, 14, 15 mm



D (mm)	L (mm)	GWÓZDŹ LEWY / LEFT NAIL			GWÓZDŹ PRAWY / RIGHT NAIL		
		$\alpha = 125^\circ$	$\alpha = 130^\circ$	$\alpha = 135^\circ$	$\alpha = 125^\circ$	$\alpha = 130^\circ$	$\alpha = 135^\circ$
10	300	X-10-01-300	X-10-02-300	X-10-03-300	X-10-16-300	X-10-17-300	X-10-18-300
10	310	X-10-01-310	X-10-02-310	X-10-03-310	X-10-16-310	X-10-17-310	X-10-18-310
10	320	X-10-01-320	X-10-02-320	X-10-03-320	X-10-16-320	X-10-17-320	X-10-18-320
10	330	X-10-01-330	X-10-02-330	X-10-03-330	X-10-16-330	X-10-17-330	X-10-18-330
10	340	X-10-01-340	X-10-02-340	X-10-03-340	X-10-16-340	X-10-17-340	X-10-18-340
10	350	X-10-01-350	X-10-02-350	X-10-03-350	X-10-16-350	X-10-17-350	X-10-18-350
10	360	X-10-01-360	X-10-02-360	X-10-03-360	X-10-16-360	X-10-17-360	X-10-18-360
10	370	X-10-01-370	X-10-02-370	X-10-03-370	X-10-16-370	X-10-17-370	X-10-18-370
10	380	X-10-01-380	X-10-02-380	X-10-03-380	X-10-16-380	X-10-17-380	X-10-18-380
10	390	X-10-01-390	X-10-02-390	X-10-03-390	X-10-16-390	X-10-17-390	X-10-18-390
10	400	X-10-01-400	X-10-02-400	X-10-03-400	X-10-16-400	X-10-17-400	X-10-18-400
10	410	X-10-01-410	X-10-02-410	X-10-03-410	X-10-16-410	X-10-17-410	X-10-18-410
10	420	X-10-01-420	X-10-02-420	X-10-03-420	X-10-16-420	X-10-17-420	X-10-18-420
10	430	X-10-01-430	X-10-02-430	X-10-03-430	X-10-16-430	X-10-17-430	X-10-18-430
10	440	X-10-01-440	X-10-02-440	X-10-03-440	X-10-16-440	X-10-17-440	X-10-18-440
11	300	X-10-04-300	X-10-05-300	X-10-06-300	X-10-19-300	X-10-20-300	X-10-21-300
11	310	X-10-04-310	X-10-05-310	X-10-06-310	X-10-19-310	X-10-20-310	X-10-21-310
11	320	X-10-04-320	X-10-05-320	X-10-06-320	X-10-19-320	X-10-20-320	X-10-21-320
11	330	X-10-04-330	X-10-05-330	X-10-06-330	X-10-19-330	X-10-20-330	X-10-21-330
11	340	X-10-04-340	X-10-05-340	X-10-06-340	X-10-19-340	X-10-20-340	X-10-21-340
11	350	X-10-04-350	X-10-05-350	X-10-06-350	X-10-19-350	X-10-20-350	X-10-21-350
11	360	X-10-04-360	X-10-05-360	X-10-06-360	X-10-19-360	X-10-20-360	X-10-21-360
11	370	X-10-04-370	X-10-05-370	X-10-06-370	X-10-19-370	X-10-20-370	X-10-21-370
11	380	X-10-04-380	X-10-05-380	X-10-06-380	X-10-19-380	X-10-20-380	X-10-21-380
11	390	X-10-04-390	X-10-05-390	X-10-06-390	X-10-19-390	X-10-20-390	X-10-21-390
11	400	X-10-04-400	X-10-05-400	X-10-06-400	X-10-19-400	X-10-20-400	X-10-21-400
11	410	X-10-04-410	X-10-05-410	X-10-06-410	X-10-19-410	X-10-20-410	X-10-21-410
11	420	X-10-04-420	X-10-05-420	X-10-06-420	X-10-19-420	X-10-20-420	X-10-21-420
11	430	X-10-04-430	X-10-05-430	X-10-06-430	X-10-19-430	X-10-20-430	X-10-21-430
11	440	X-10-04-440	X-10-05-440	X-10-06-440	X-10-19-440	X-10-20-440	X-10-21-440
12	300	X-10-07-300	X-10-08-300	X-10-09-300	X-10-22-300	X-10-23-300	X-10-24-300
12	310	X-10-07-310	X-10-08-310	X-10-09-310	X-10-22-310	X-10-23-310	X-10-24-310
12	320	X-10-07-320	X-10-08-320	X-10-09-320	X-10-22-320	X-10-23-320	X-10-24-320
12	330	X-10-07-330	X-10-08-330	X-10-09-330	X-10-22-330	X-10-23-330	X-10-24-330
12	340	X-10-07-340	X-10-08-340	X-10-09-340	X-10-22-340	X-10-23-340	X-10-24-340
12	350	X-10-07-350	X-10-08-350	X-10-09-350	X-10-22-350	X-10-23-350	X-10-24-350
12	360	X-10-07-360	X-10-08-360	X-10-09-360	X-10-22-360	X-10-23-360	X-10-24-360
12	370	X-10-07-370	X-10-08-370	X-10-09-370	X-10-22-370	X-10-23-370	X-10-24-370
12	380	X-10-07-380	X-10-08-380	X-10-09-380	X-10-22-380	X-10-23-380	X-10-24-380
12	390	X-10-07-390	X-10-08-390	X-10-09-390	X-10-22-390	X-10-23-390	X-10-24-390
12	400	X-10-07-400	X-10-08-400	X-10-09-400	X-10-22-400	X-10-23-400	X-10-24-400
12	410	X-10-07-410	X-10-08-410	X-10-09-410	X-10-22-410	X-10-23-410	X-10-24-410
12	420	X-10-07-420	X-10-08-420	X-10-09-420	X-10-22-420	X-10-23-420	X-10-24-420
12	430	X-10-07-430	X-10-08-430	X-10-09-430	X-10-22-430	X-10-23-430	X-10-24-430
12	440	X-10-07-440	X-10-08-440	X-10-09-440	X-10-22-440	X-10-23-440	X-10-24-440

Gwoździe są dostępne dla długości L = 300 - 600 mm, skok co 5 mm, ostatni człon numeru katalogowego oznacza długość w [mm]

Gwoździe są dostępne również dla średnic D = 9, 13, 14, 15, 16, 17, 18, 19 mm

Available in lengths L = 300 - 600 mm, last part of catalogue number is length in [mm]. Available also for diameter D = 9, 13, 14, 15, 16, 17, 18, 19 mm

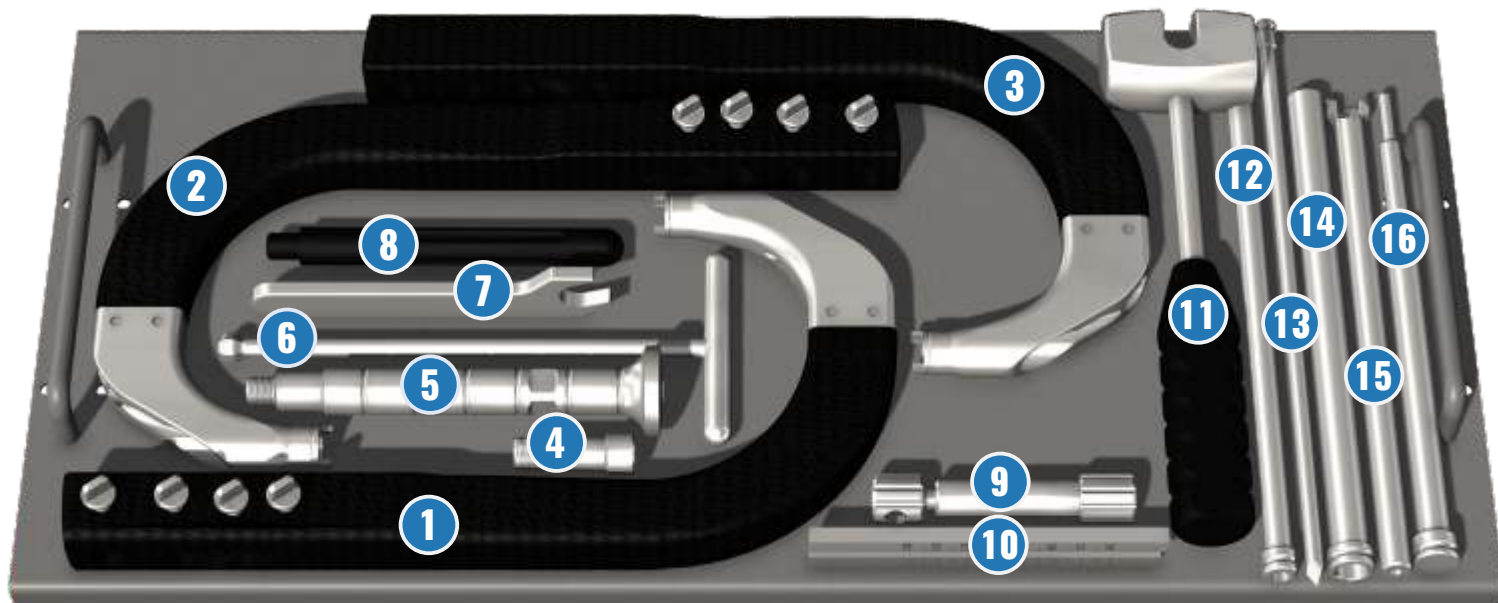

- |           |                   |                                      |
|-----------|-------------------|--------------------------------------|
| <b>1</b>  | <b>4-51-01-88</b> | Targeting device 125°                |
| <b>2</b>  | <b>4-51-01-89</b> | Targeting device 130°                |
| <b>3</b>  | <b>4-51-01-90</b> | Targeting device 135°                |
| <b>4</b>  | <b>4-51-01-22</b> | Nail holding screw M12               |
| <b>5</b>  | <b>4-51-01-23</b> | Strike plate                         |
| <b>6</b>  | <b>4-51-01-24</b> | Screwdriver 10mm,                    |
| <b>7</b>  | <b>4-50-00-41</b> | Wrench                               |
| <b>8</b>  | <b>4-51-01-46</b> | Axial indicator                      |
| <b>9</b>  | <b>4-50-00-18</b> | Guide wire handle                    |
| <b>10</b> | <b>4-50-01-12</b> | Lag screw gauge                      |
| <b>11</b> | <b>4-51-01-16</b> | Slotted Hammer                       |
| <b>12</b> | <b>4-51-01-92</b> | ø6,5 drill sleeve                    |
| <b>13</b> | <b>4-51-01-37</b> | Trocar                               |
| <b>14</b> | <b>4-51-01-91</b> | Lag screw drill sleeve for ø11 drill |
| <b>15</b> | <b>4-51-01-36</b> | K-wire sleeve                        |
| <b>16</b> | <b>4-50-00-22</b> | Control Pin ø4,6                     |

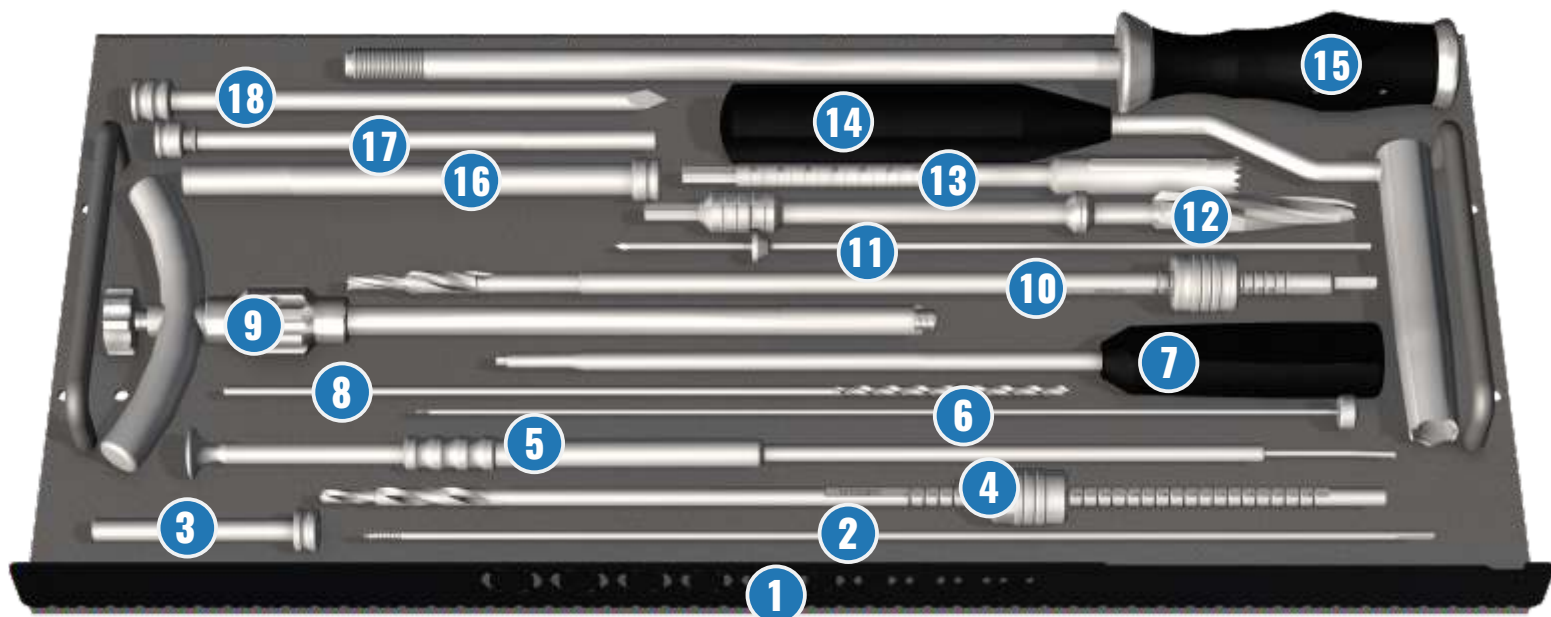

- |           |                     |   |
|-----------|---------------------|---|
| <b>1</b>  | <b>4-50-18-09</b>   | Ruler   |
| <b>2</b>  | <b>4-50-00-19</b>   | Kirschner wire $\varnothing 3,0 \times 370 \text{mm}$ x2      |
| <b>3</b>  | <b>4-50-00-38</b>   | Sleeve of hand targeting device                               |
| <b>4</b>  | <b>4-50-02-07</b>   | Anti-rotation screw Drill $\varnothing 4,8 / \varnothing 6,5$ |
| <b>5</b>  | <b>4-50-14-02</b>   | Bone thickness gauge  |
| <b>6</b>  | <b>4-51-01-19.2</b> | Locking screw of 4-51-01-19                                   |
| <b>7</b>  | <b>4-51-01-19</b>   | Cannulated screwdriver s3,5                                   |
| <b>8</b>  | <b>4-50-00-30</b>   | Drill $\varnothing 3,7$ x2                                    |
| <b>9</b>  | <b>4-51-01-12</b>   | Lag screwdriver   |
| <b>10</b> | <b>4-51-01-21</b>   | Lag screw step drill $\varnothing 11$                         |
| <b>11</b> | <b>4-51-01-15</b>   | Trepan guide wire   |
| <b>12</b> | <b>4-51-01-10</b>   | Reamer  |
| <b>13</b> | <b>4-51-01-13</b>   | Trepan drill  |
| <b>14</b> | <b>4-51-01-11</b>   | Soft tissue protection sleeve                                 |
| <b>15</b> | <b>4-51-01-47</b>   | Extractor rod   |
| <b>16</b> | <b>4-50-00-29</b>   | Protection sleeve   |
| <b>17</b> | <b>4-50-00-371</b>  | Drill sleeve for $\varnothing 3,7$ drill                      |
| <b>18</b> | <b>4-50-00-57</b>   | Trocar  |

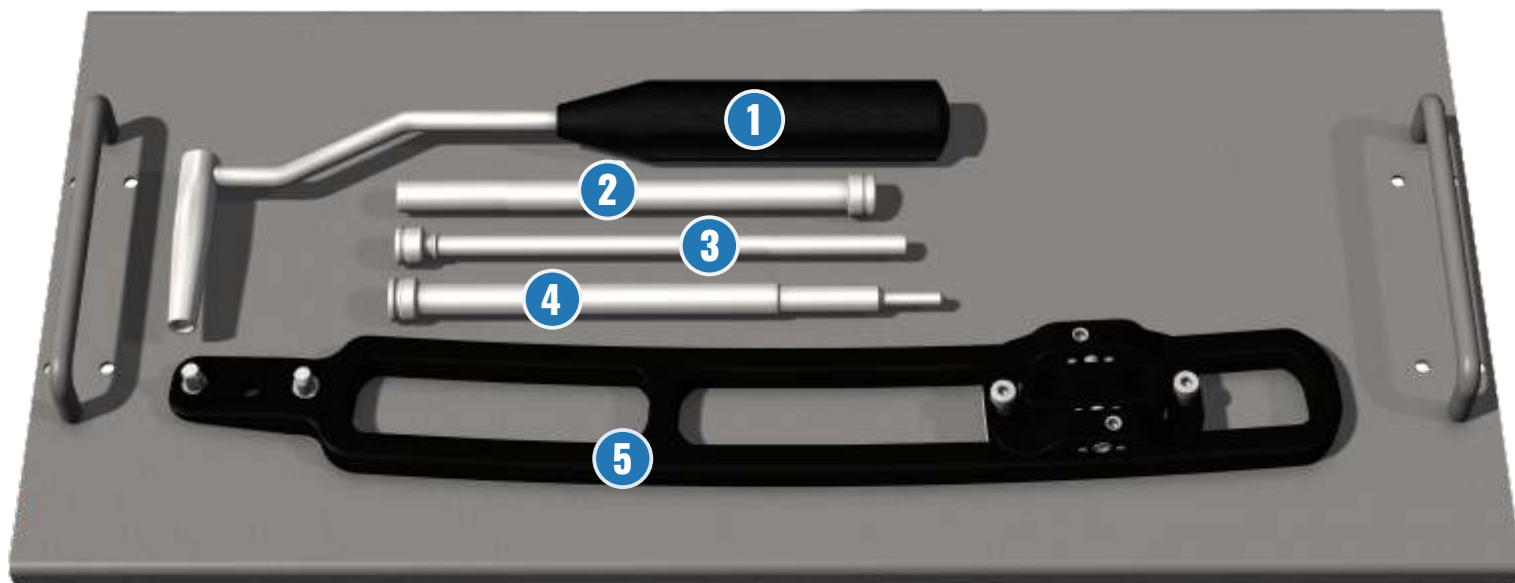

- |          |                    |  |
|----------|--------------------|--|
| <b>1</b> | <b>4-50-00-03</b>  | Hand targeting device                    |
| <b>2</b> | <b>4-50-00-29</b>  | Protection sleeve                        |
| <b>3</b> | <b>4-50-00-371</b> | Drill sleeve for $\varnothing 3,7$ drill |
| <b>4</b> | <b>4-50-00-22</b>  | Control Pin $\varnothing 4,6$            |
| <b>5</b> | <b>4-51-07-01</b>  | Distal targeting device                  |





SUGGESTED PATIENT'S POSITION





## ASSEMBLY CHECK

Connect the monolith handle **4-51-01-88/89/90** with the nail using the nail holding screw **4-51-01-22**.

Use the ball-tip screwdriver **4-51-01-24**.

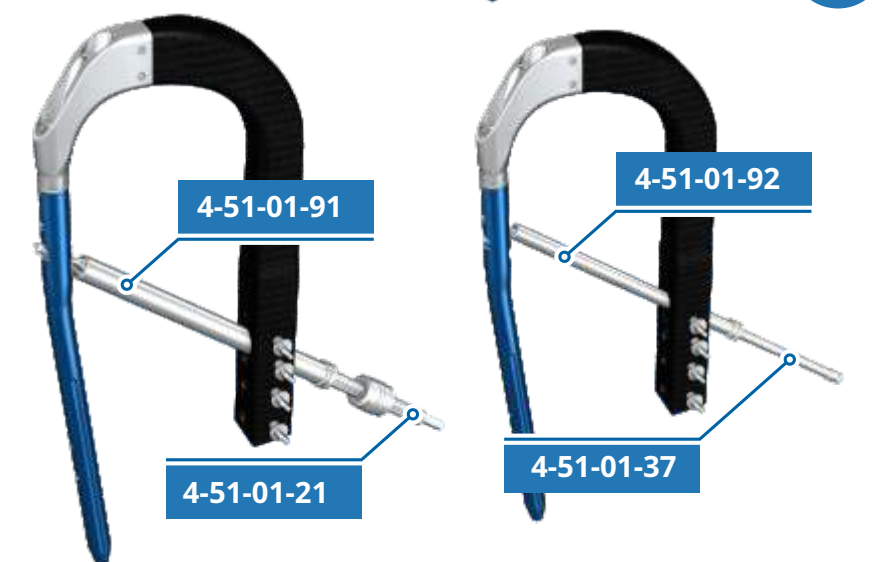

Check the lag screw hole using the sleeve **4-51-01-91** and the step drill **4-51-01-21**.

Check the anti-rotation screw hole using the sleeve **4-51-01-92** and the trocar **4-51-01-37**.



Check the distal holes using the control pin **4-50-00-22**.

01

## BONE PREPARATION

Set the correct angle for insertion of the trepan guide wire **4-51-01-15** into the bone.

Insert the trepan guide wire **4-51-01-15** into the bone.

02

Using the sleeve **4-51-01-11** and the trepan **4-51-01-13**, open the bone medullary canal.

03

Using the cannulated reamer **4-51-01-10**, prepare the bone for the proximal part of the nail.

Control the reaming depth using the gauge on the reamer.

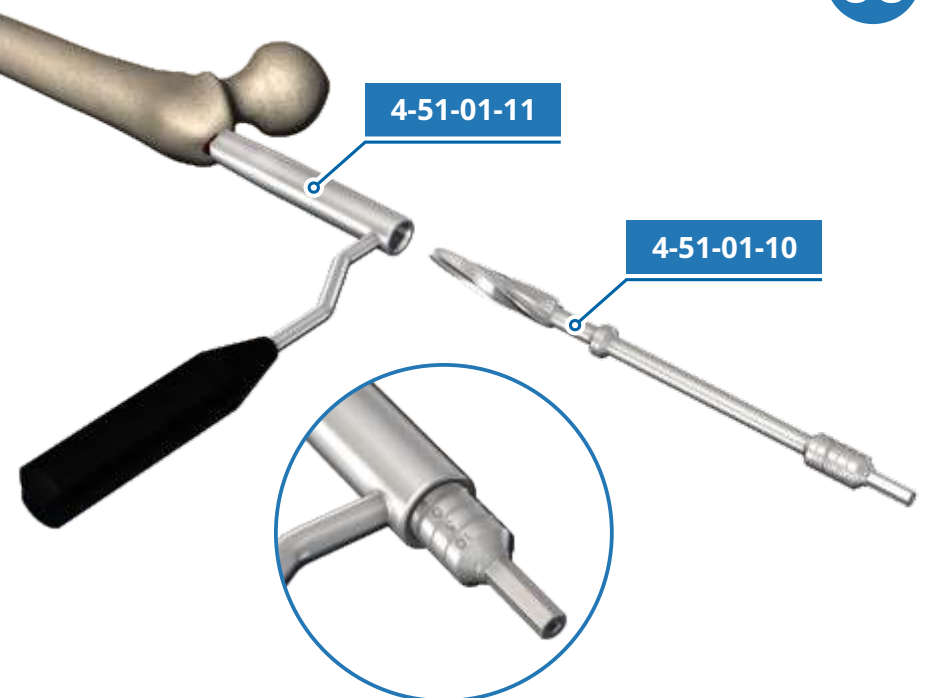
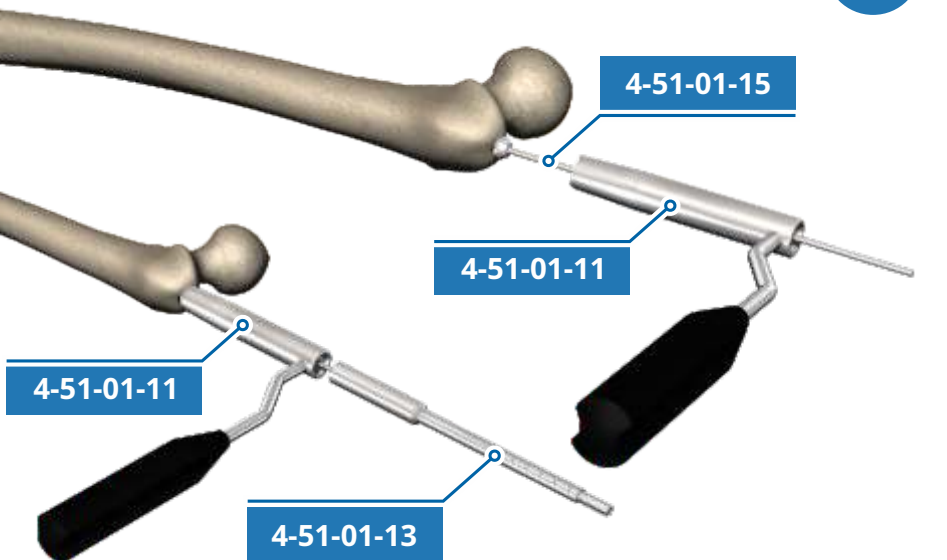
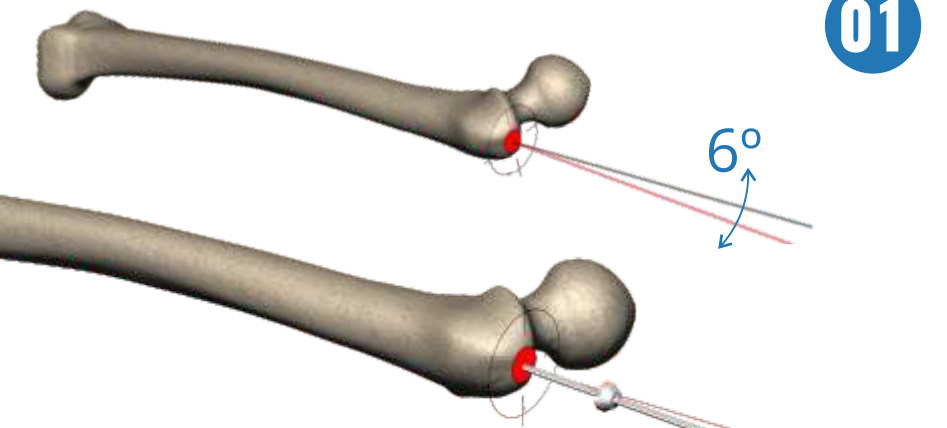

01

## NAIL INSERTION

Insert the nail into the bone using the monolith handle **4-51-01-xx**. Use appropriate handle for each angle: 125 or 130 or 135°

For insertion use the strike plate **4-51-01-23** and the hammer **4-51-01-16**.

**Always use wrench 4-50-01-41 for tightening the strike plate.**  
(to avoid thread damaging)

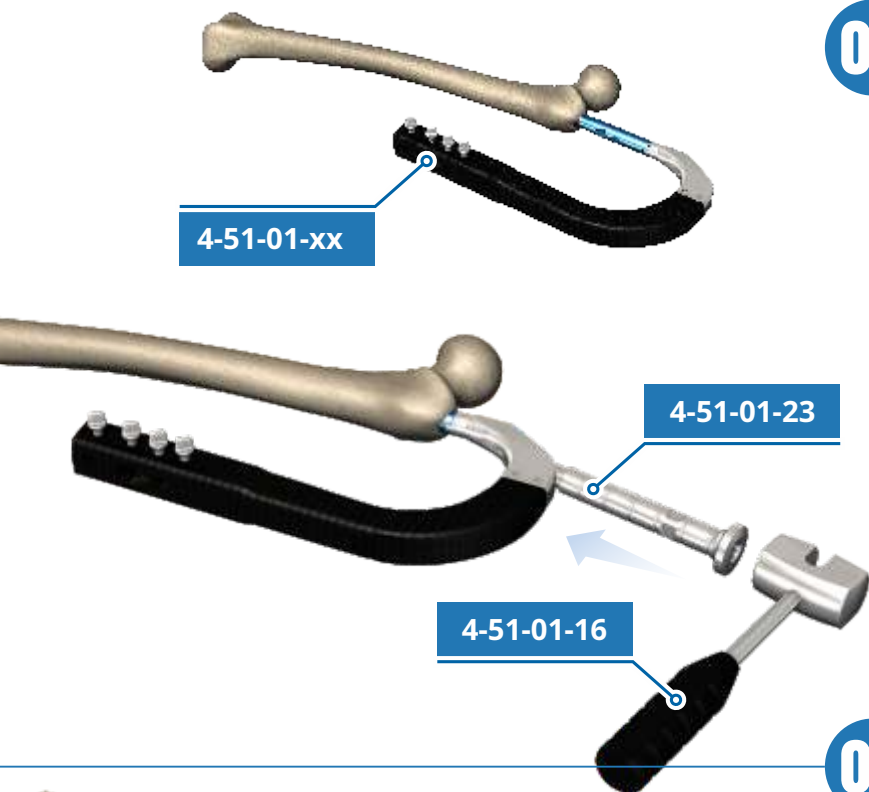

02

If necessary, use the hammer **4-51-01-16** and the extractor rod **4-51-01-47** to adjust the position of the nail in the bone.

Observe the wire indications.

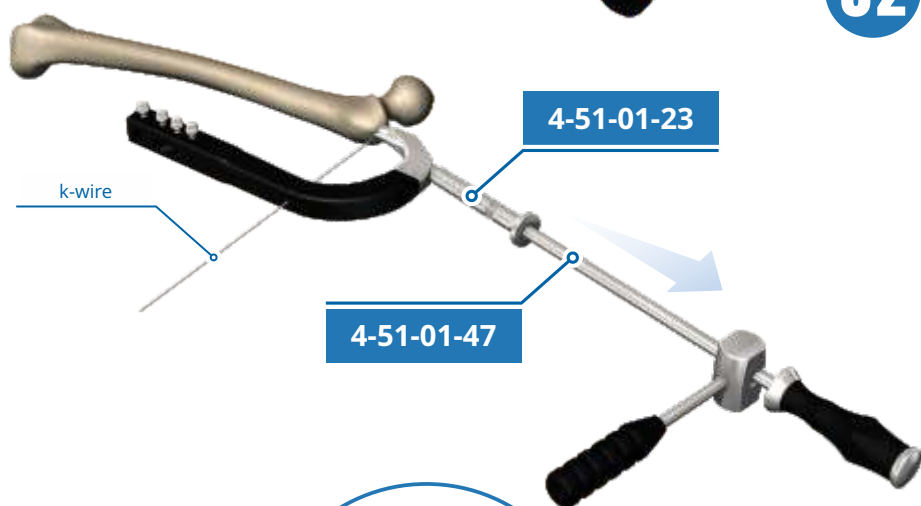

03

Use the axial indicator to determine the position of the lag screw in the bone.

Check the X-ray in axial projection.

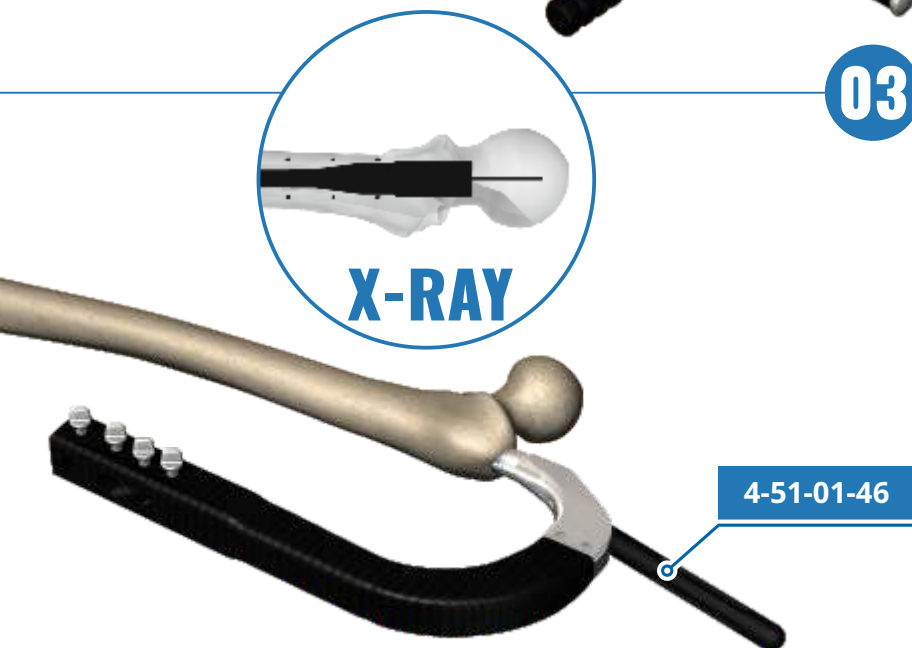

01

## LOCKING with the LAG SCREW and the ANTI-ROTATION SCREW

Insert the K-wire **4-50-00-19** through the sleeves **4-51-01-91** and **4-51-01-36**, up to the subchondral layer.

Lock the sleeve on the handle.

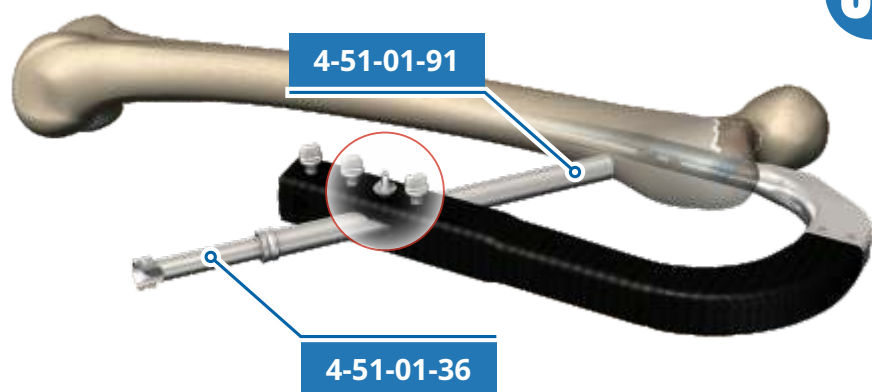

02

Measure the depth of insertion of the guide wire into the bone using the gauge **4-50-01-12**.

Determine the length of the lag screw and the anti-rotation screw. The length of the lag screw should be 10-15 mm shorter than measured length.

The anti-rotation screw should pass through the fracture plane.

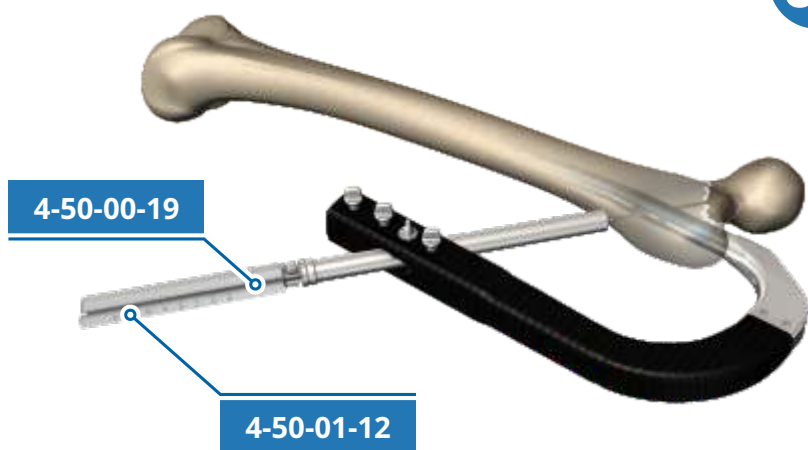

03

Insert the sleeve **4-51-01-92** and lock it in the handle.

Before drilling a hole for the anti-rotation screw, prepare the cortical bone using the trocar **4-51-01-37**.

Drill a hole to the previously determined depth using the step drill **4-50-02-07**.

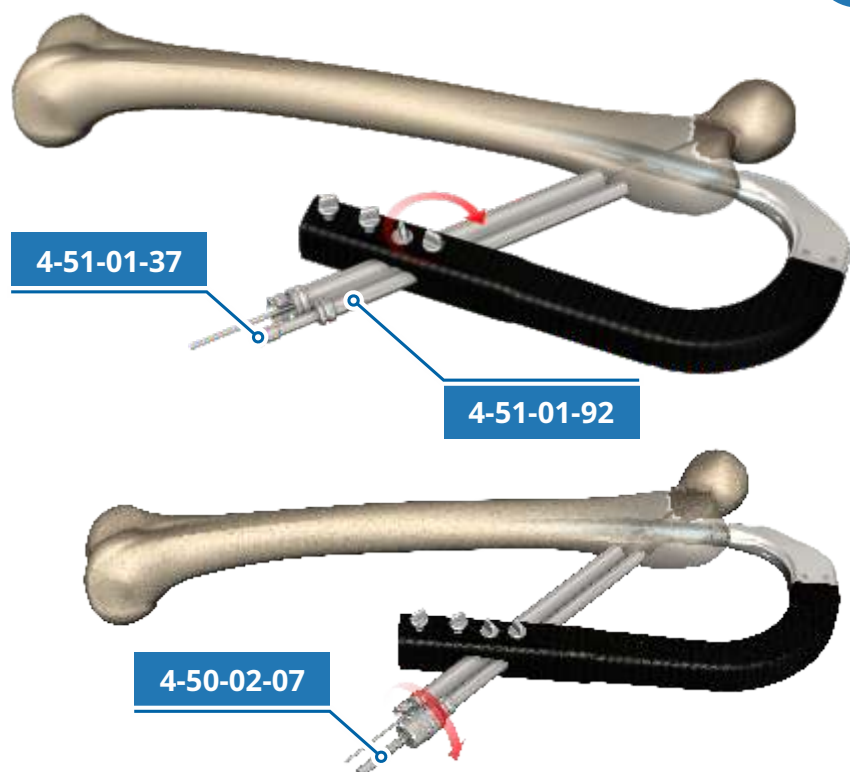

04

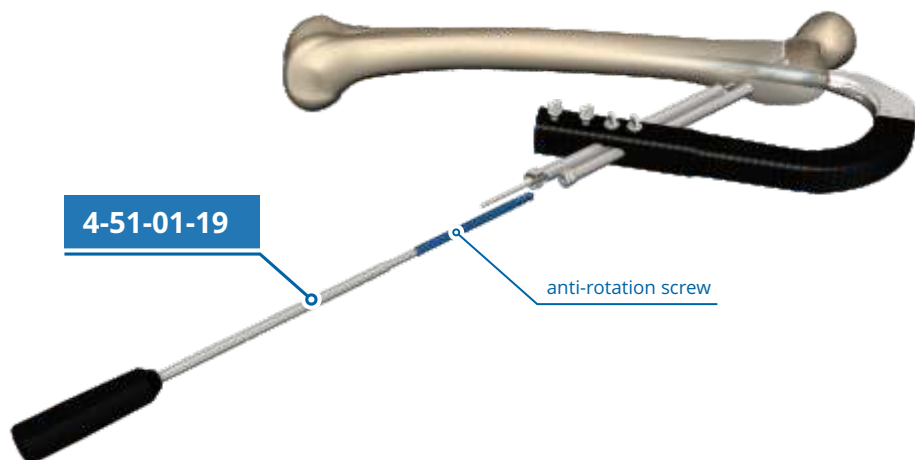

Insert the anti-rotation screw using the screwdriver **4-51-01-19**.

05

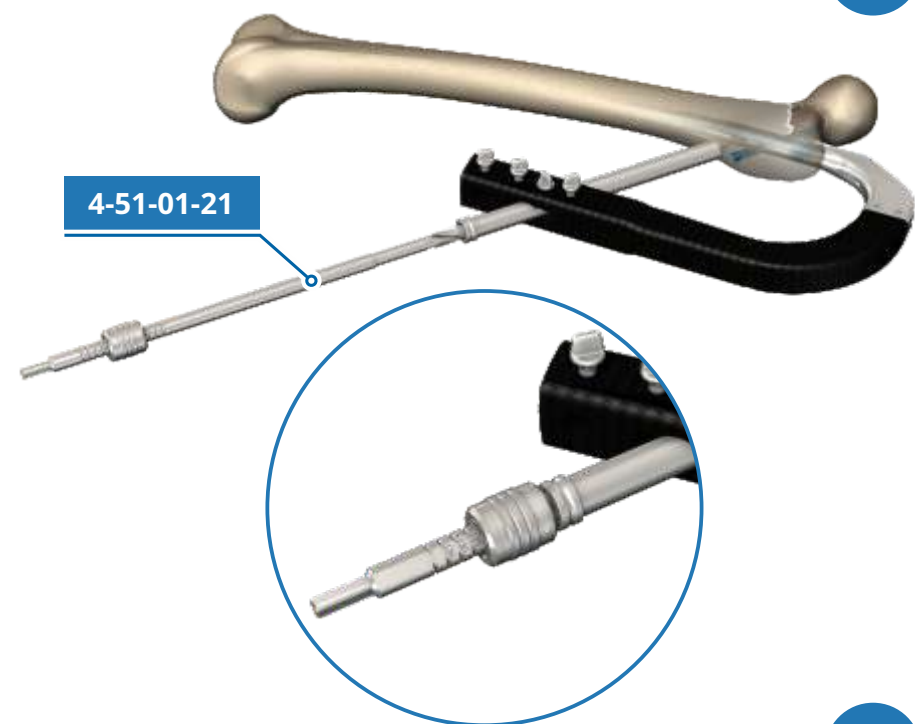

Make a hole for the lag screw using the step drill **4-51-01-21**.

Drill to the depth in accordance with the previous measurement.

06

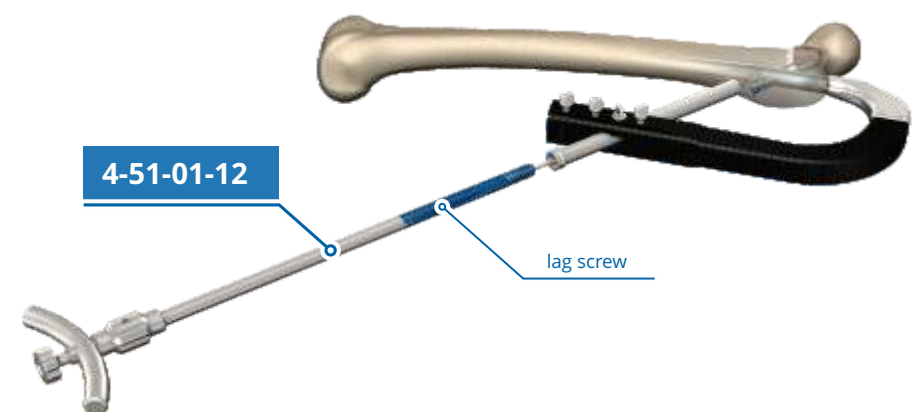

Install the lag screw on the lag screwdriver **4-51-01-12**.

Insert the lag screw using the lag screwdriver.

07

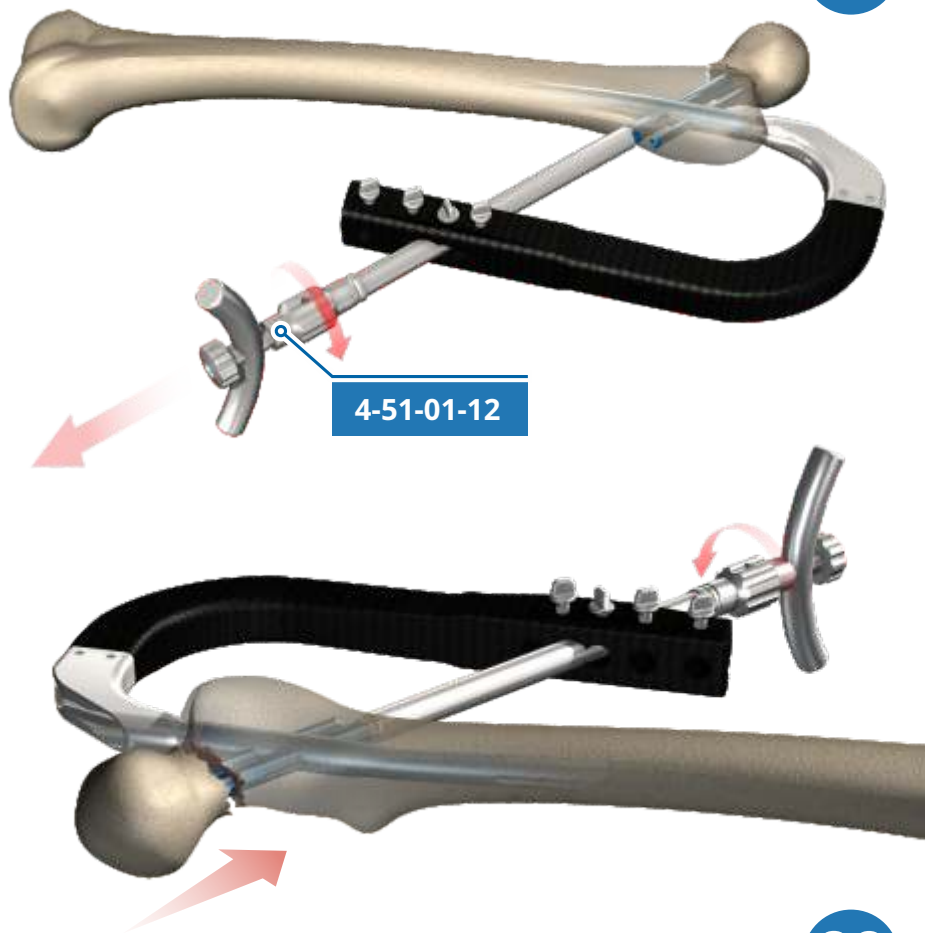

Compress the fracture.  
In order to do this, turn the knob on the screwdriver in the direction of the sleeve.

08

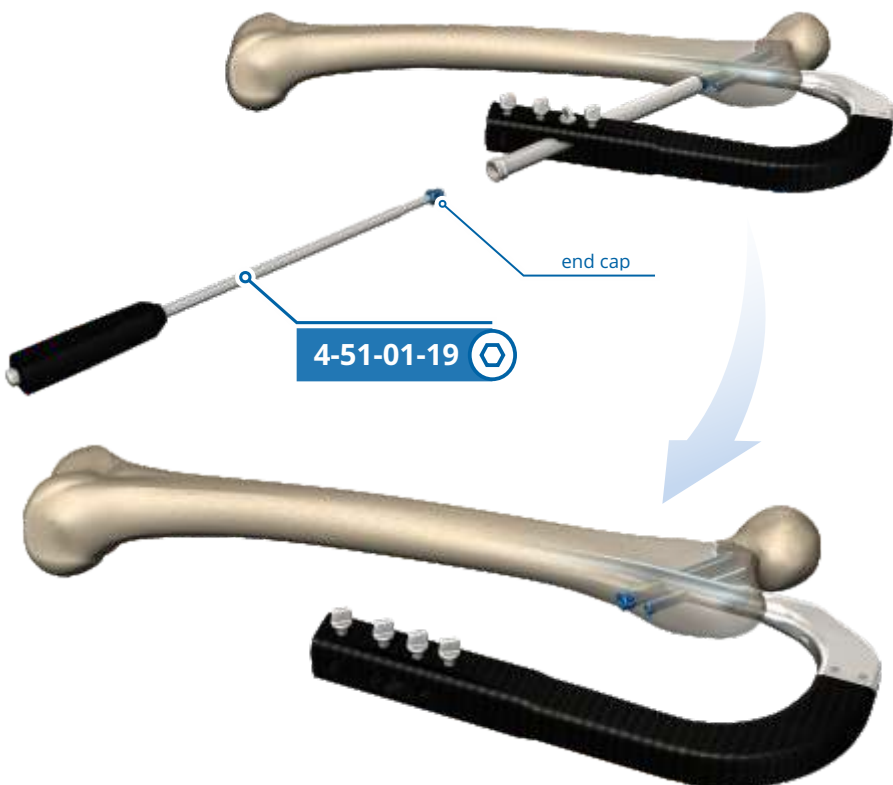

Insert the end cap in the lag screw. The end cap should be locked on the screwdriver **4-51-01-19 + 4-51-01-19.2**.

01

## LOCKING with use of ONLY STANDARD LAG SCREW

Insert the standard lag screw using the lag screwdriver **4-51-01-12**.

Compress using the knob on the lag screwdriver.

### IMPORTANT!

The position of the screwdriver should be perpendicular or parallel to the monolith handle.

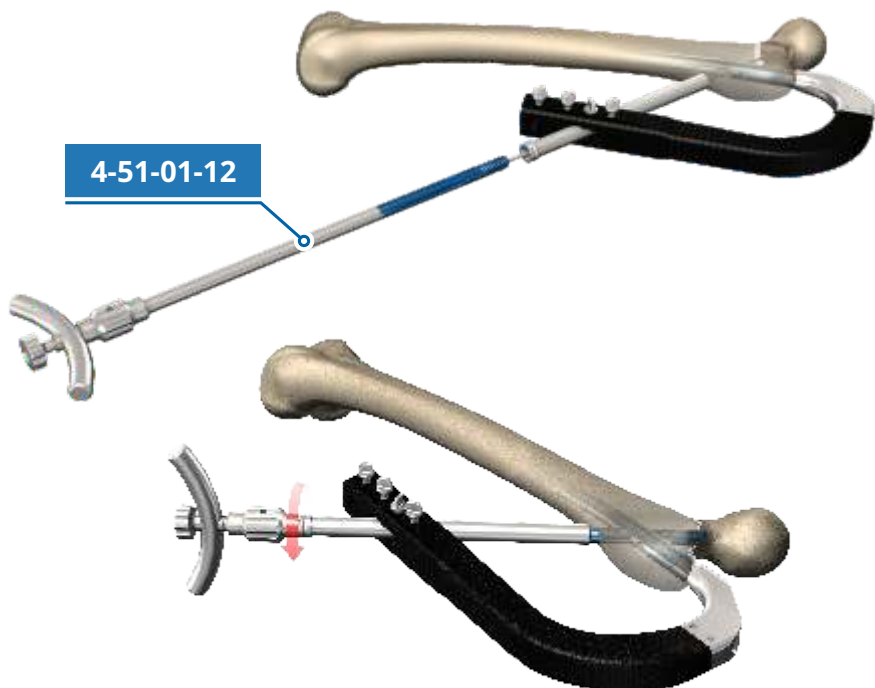

02

Insert the set screw into the nail — until you can feel the contact with the lag screw.

### NOTE!

The set screw should be locked on the screwdriver:

**4-51-01-19 + 4-51-01-19.2**

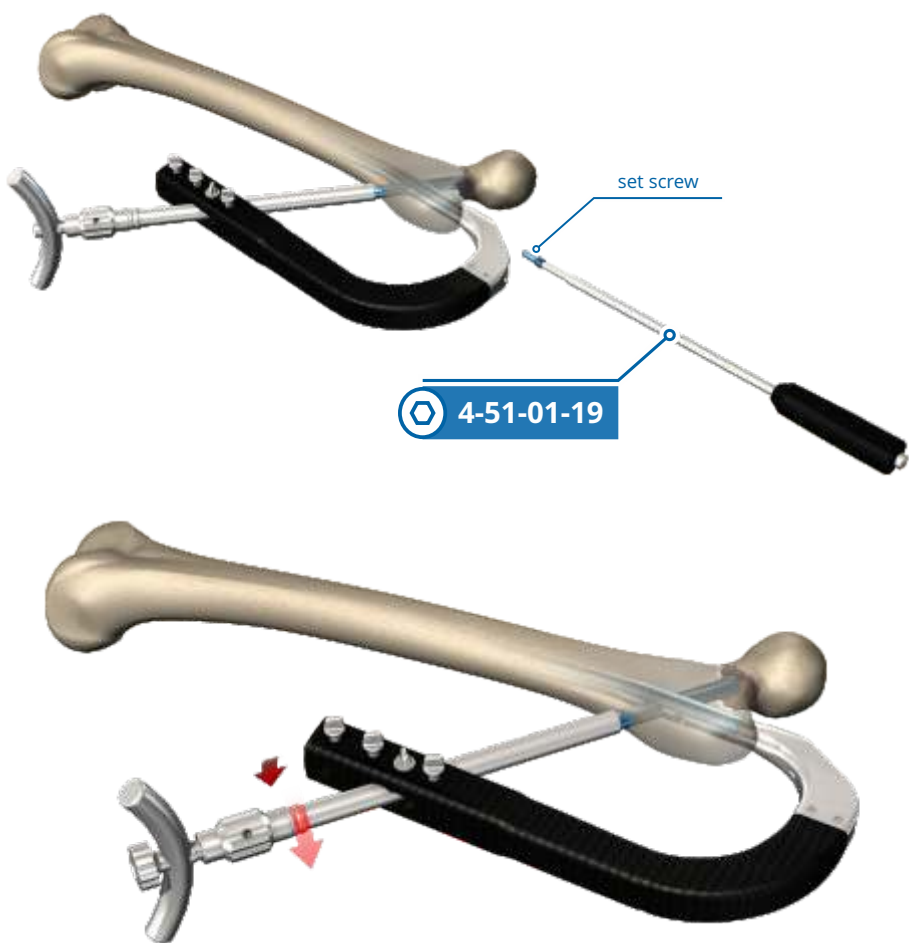

Try to turn the lag screwdriver in order to verify if the lag screw is locked correctly. If you are unable to turn it, it means that the locking point is correct.



03

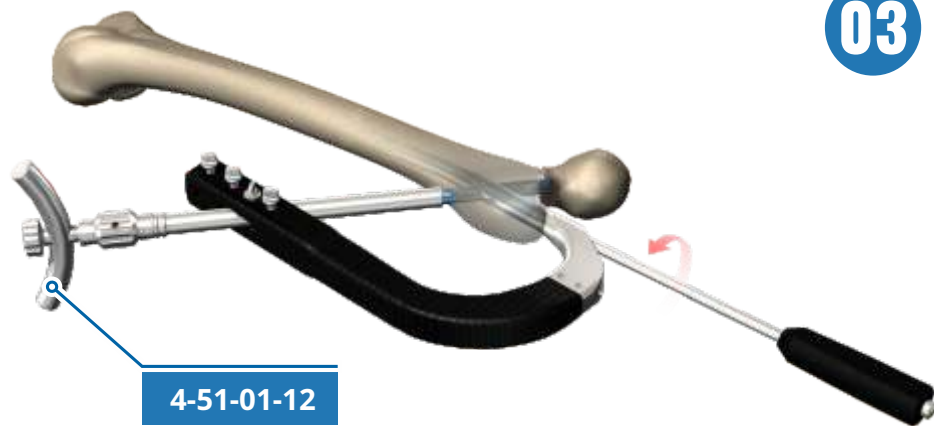

Loosen the set screw by turning the screwdriver by half a turn.

**INFO:**

This results in obtaining a dynamic connection (axial movement) between the lag screw and the set screw, with no rotational movements.

**IMPORTANT!**

No dynamisation may cause nail fracture in the postoperative period.

04

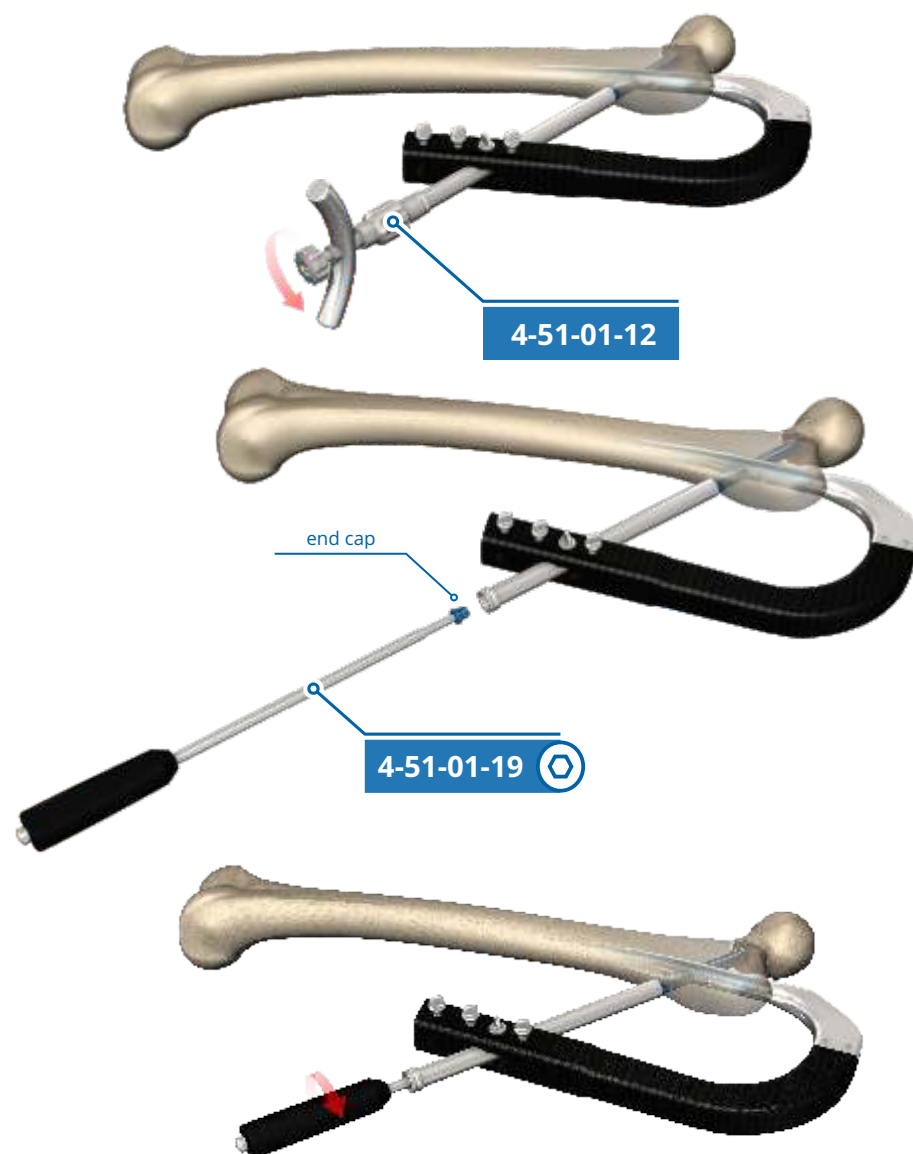

Remove the lag screwdriver **4-51-01-12** from the lag screw.

Insert the end cap in the lag screw using the screwdriver.

**NOTE!**

The end cap should be locked on the screwdriver: **4-51-01-19 + 4-51-01-19.2**

## TELESCPIC LAG SCREW

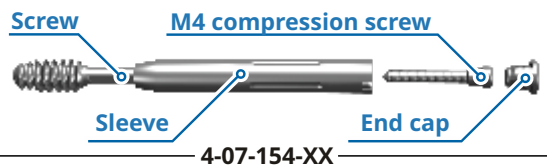

01

### LOCKING with use of ONLY TELESCOPIC LAG SCREW

Insert the telescopic lag screw using the lag screwdriver **4-51-01-12**.

02

Remove the guide wire.  
Insert the set screw into the nail.

#### NOTE!

The set screw should be locked on the screwdriver:

**4-51-01-19 + 4-51-01-19.2**

03

Insert the **M4** compression screw to the lag screw. Compress the fracture.

#### NOTE!

The set screw should be locked on the screwdriver:

**4-51-01-19 + 4-51-01-19.2**

04

Insert the end cap in the lag screw.

#### NOTE!

The end cap should be locked on the screwdriver:

**4-51-01-19 + 4-51-01-19.2**

4-51-01-19

set screw

4-51-01-19

M4 screw

4-51-01-19

end cap

01

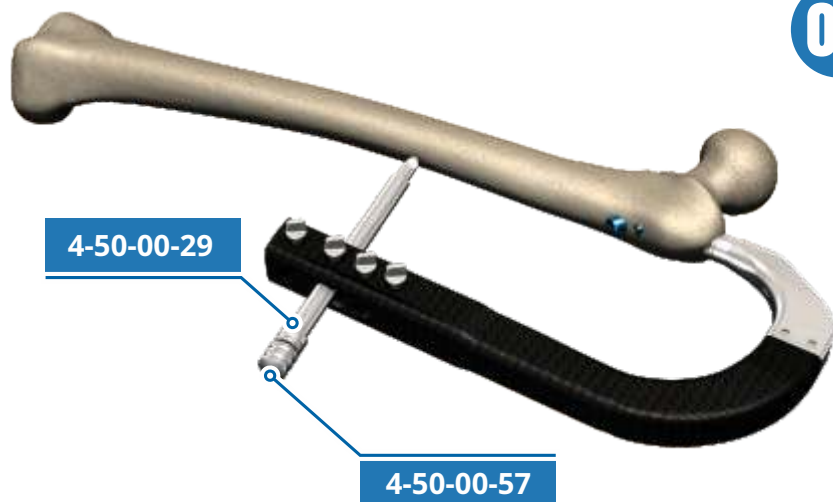

## DISTAL LOCKING

Prepare the cortical bone using the sleeve 4-50-00-29 and the trocar 4-50-00-57.

02

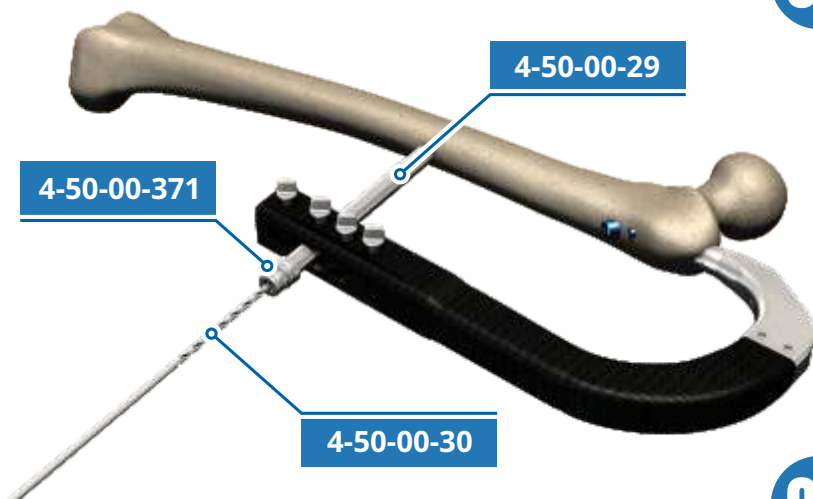

Insert the drilling sleeve 4-50-00-371 into the sleeve 4-50-00-29 and drill a hole.

03

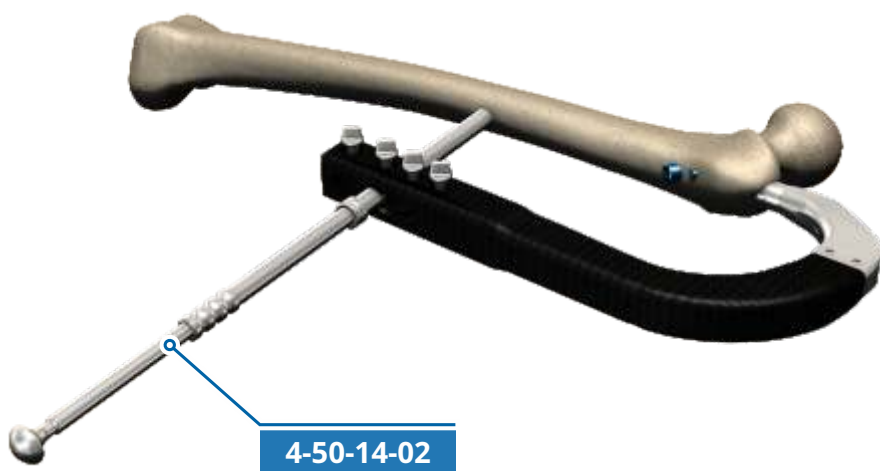

Measure the bone thickness using the gauge 4-50-14-02.  
Choose the right screw.

### NOTE!

- DYNAMIC locking
  - drill only through the DYN hole
- STATIC locking
  - drill through both static and dynamic holes or only the static hole.

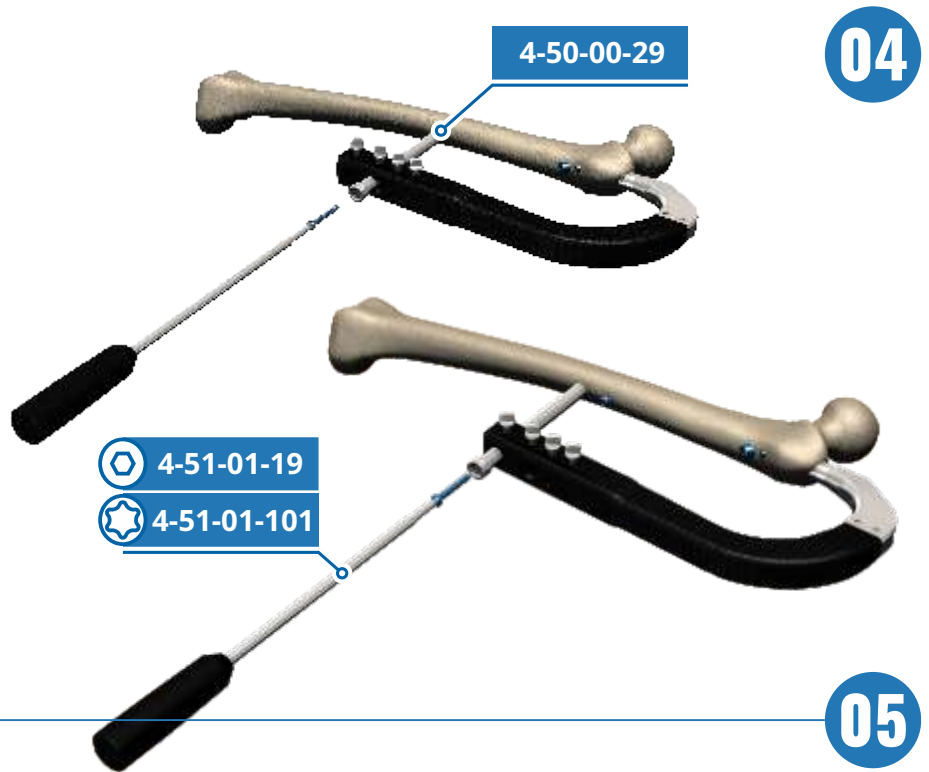

Insert appropriate screws through the sleeve **4-50-00-29** using the screwdriver **4-51-01-19**.

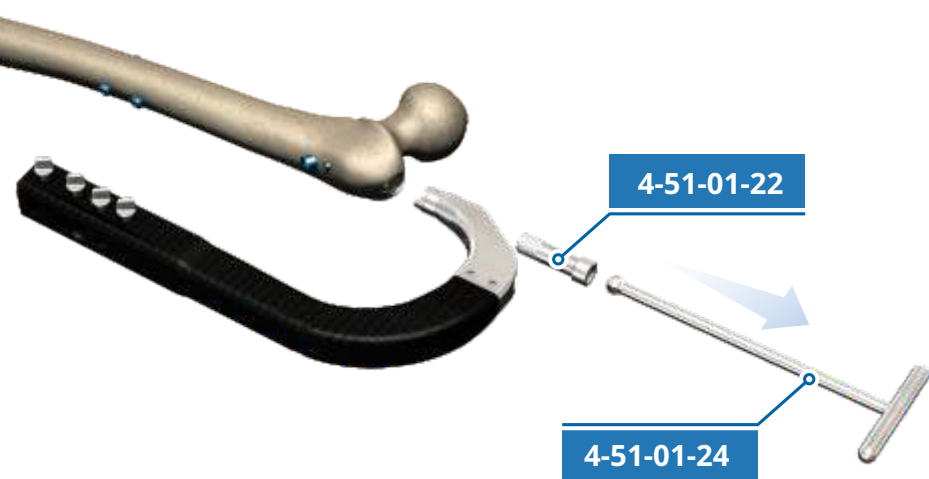

Remove the nail holding screw **4-51-01-22** using the ball-tip screwdriver **4-51-01-24**.

Remove the complete monolith handle from the nail.

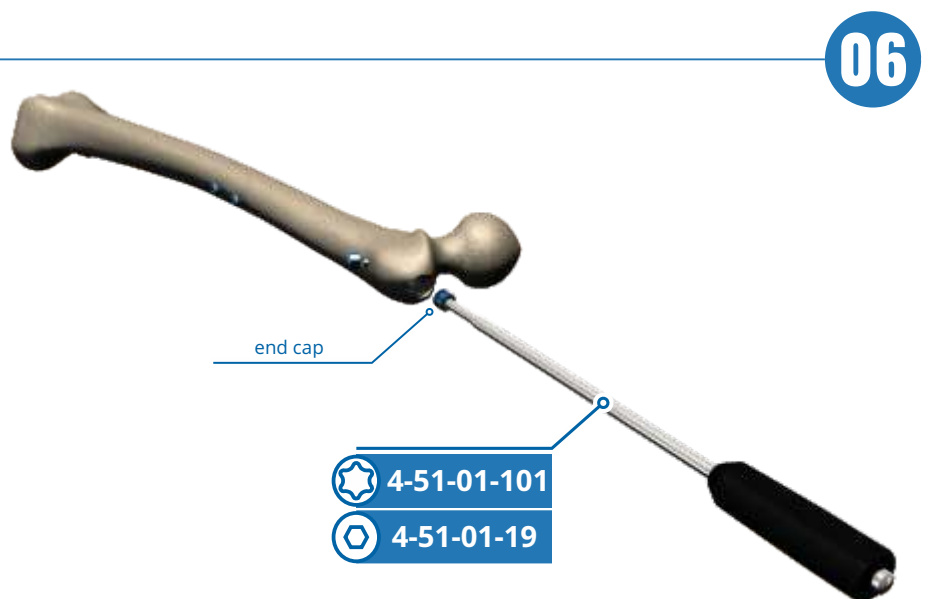

Insert the end cap in the nail using the screwdriver **4-51-01-19**.

**NOTE!**

The nail end cap should be locked on the screwdriver:

**4-51-01-19 + 4-51-01-19.2**

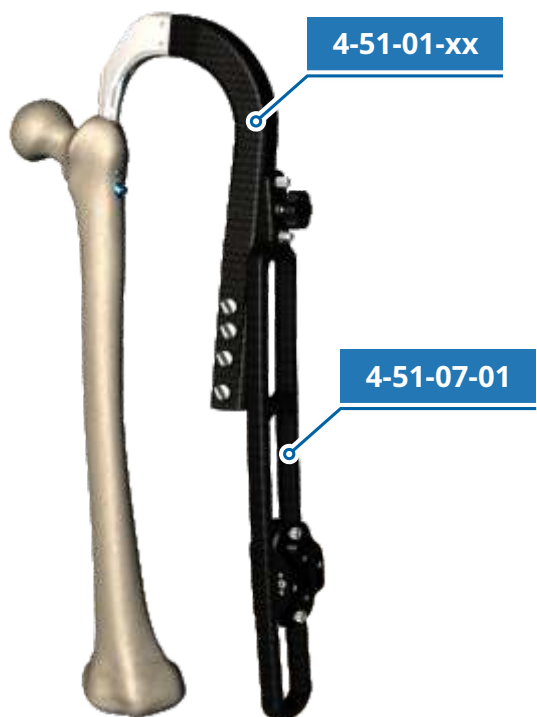

01

## DISTAL TARGETING DEVICE

Install distal targeting device **4-51-07-01**, do not change position of the targeting device.

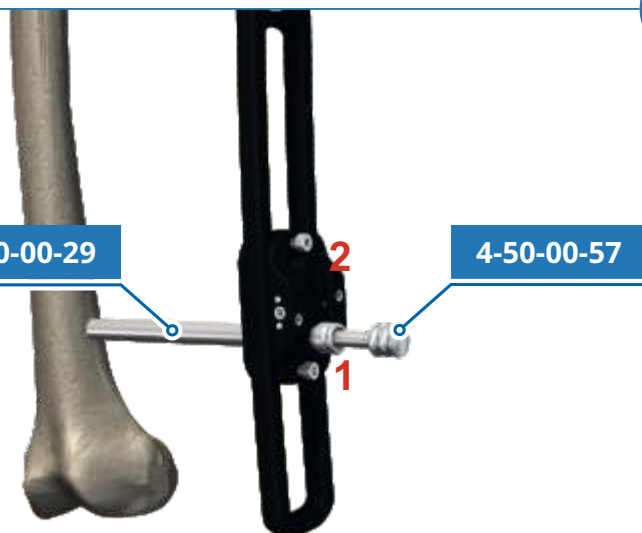

02

Prepare distal hole using trocar **4-50-00-57** through sleeve **4-50-00-29**

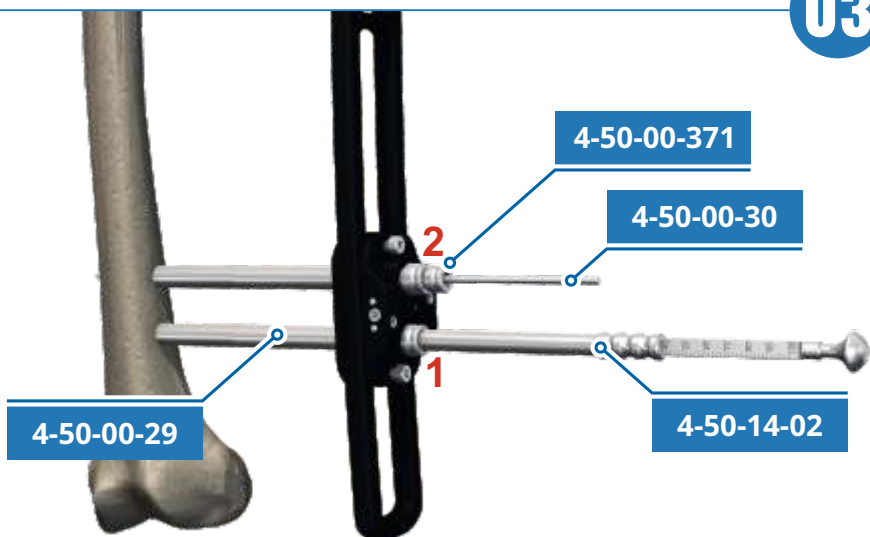

03

Drill through the second distal nail hole using sleeve **4-50-00-29**, sleeve **4-50-00-371** and drill **4-50-00-30**. Leave the drill. Drill through the first distal nail hole in the same way like second hole. Measure the depth of drilling through the first drilled hole, with bone thickness gauge **4-50-14-02** in order to determine the length of locking screw.

04

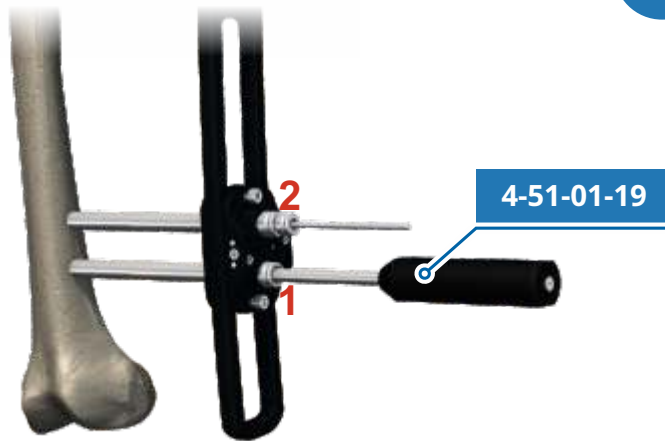

Insert  $\varnothing 4,5$  mm locking screw in the first drilled hole using screwdriver **4-50-01-19**

05

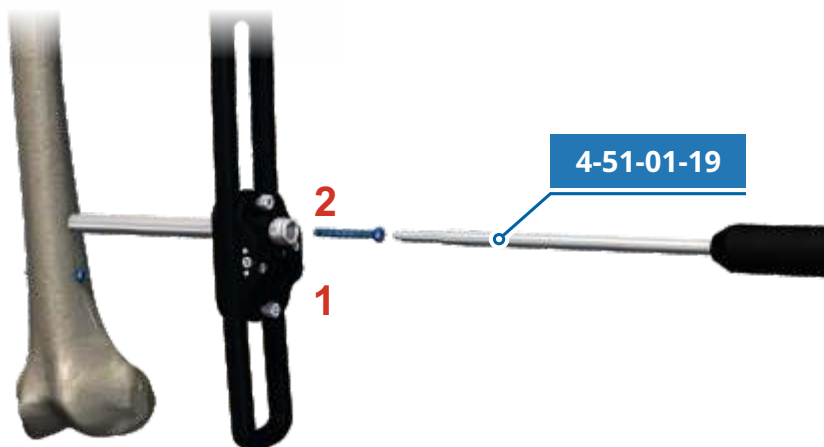

Measure the depth of drilling through the second drilled hole in the same way like the first hole.

Insert  $\varnothing 4,5$ mm locking screw into second drilled hole using screwdriver **4-51-01-19**.

06

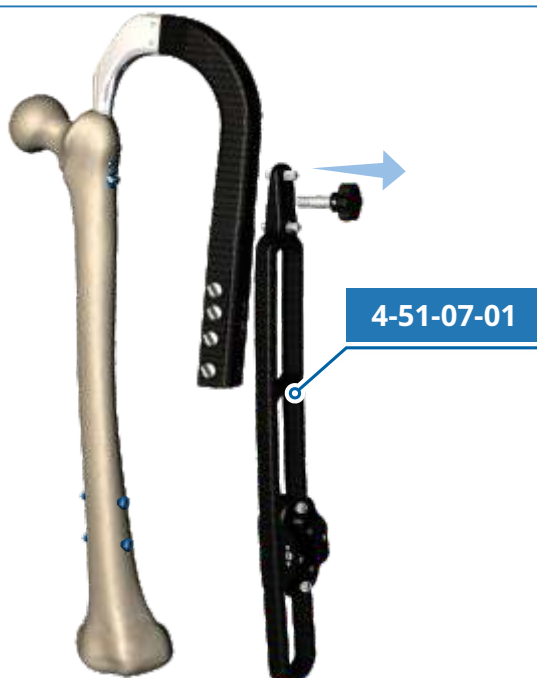

Disassemble targeting device.

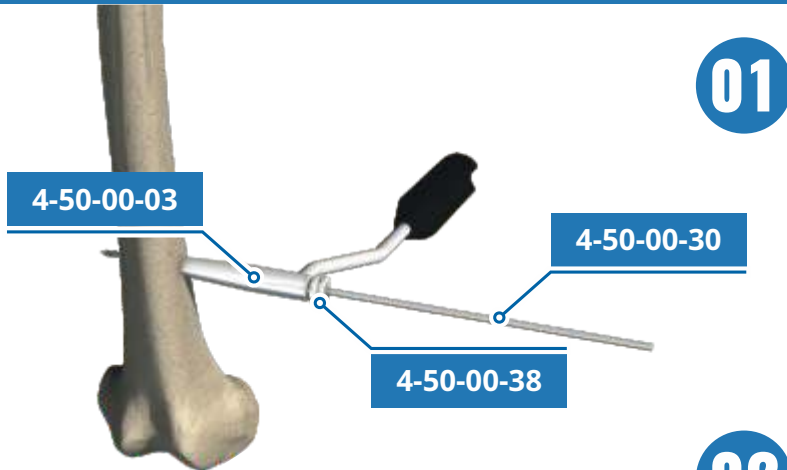

## FREEHAND LOCKING TECHNIQUE

Drill first distal nail hole using hand targeting device **4-50-00-03** and sleeve **4-50-00-38** and drill **4-50-00-30**



Measure the depth of drilling through the drilled hole, with bone thickness gauge **4-50-14-02** in order to determine the length of locking screw.

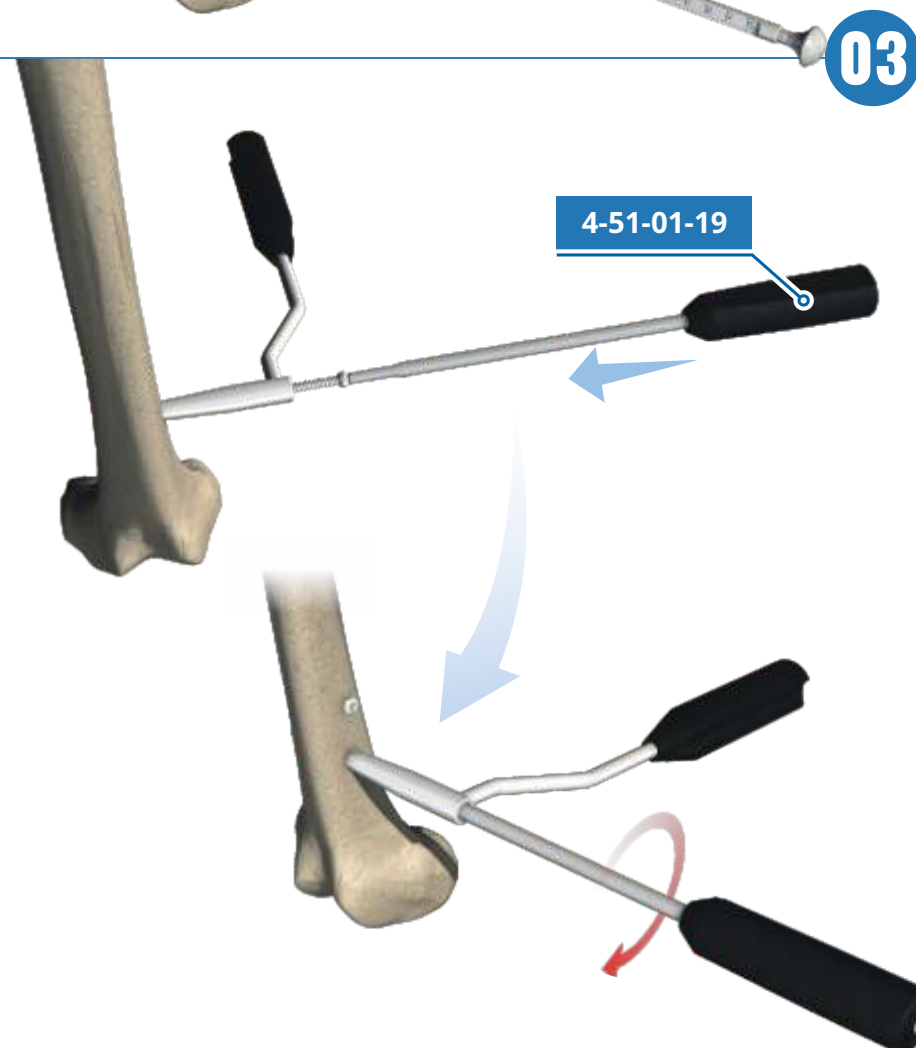

Insert  $\varnothing 4,5$  mm locking screw in first drilled hole using screwdriver **4-51-01-19**

Lock second distal hole in the same way like the first distal hole.

01

## REMOVAL OF THE NAIL WITHOUT THE ANTI-ROTATION SCREW

Remove the end cap from the nail.  
Remove the end cap from the lag screw.

### NOTE!

The end cap should be locked on the screwdriver **4-51-01-19** + **4-51-01-19.2**.

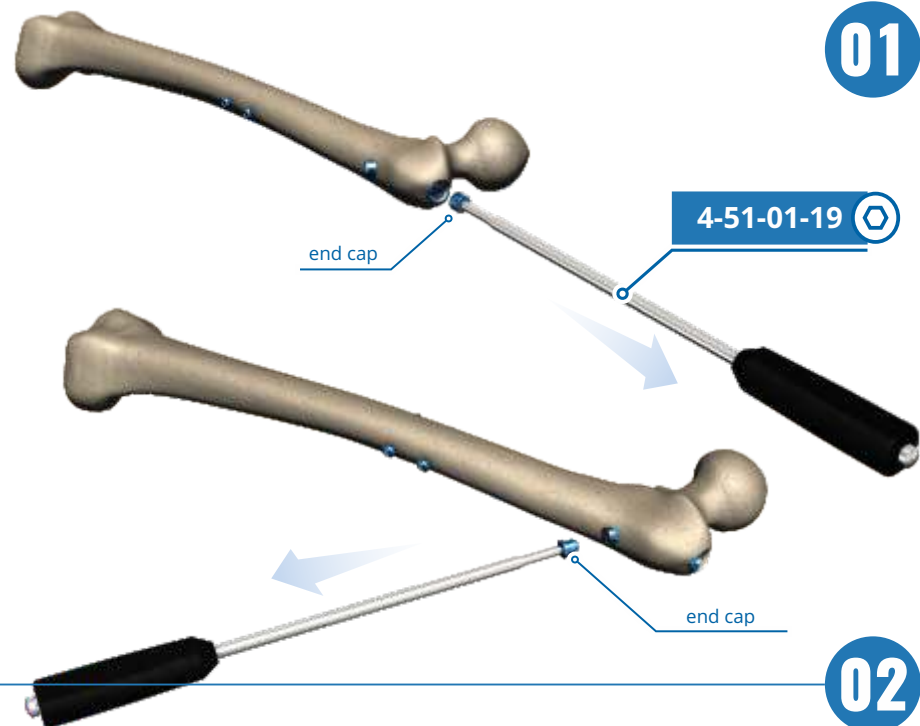

02

Install the lag screwdriver **4-51-01-12** on the lag screw and remove the set screw from the nail. Remove the lag screw.

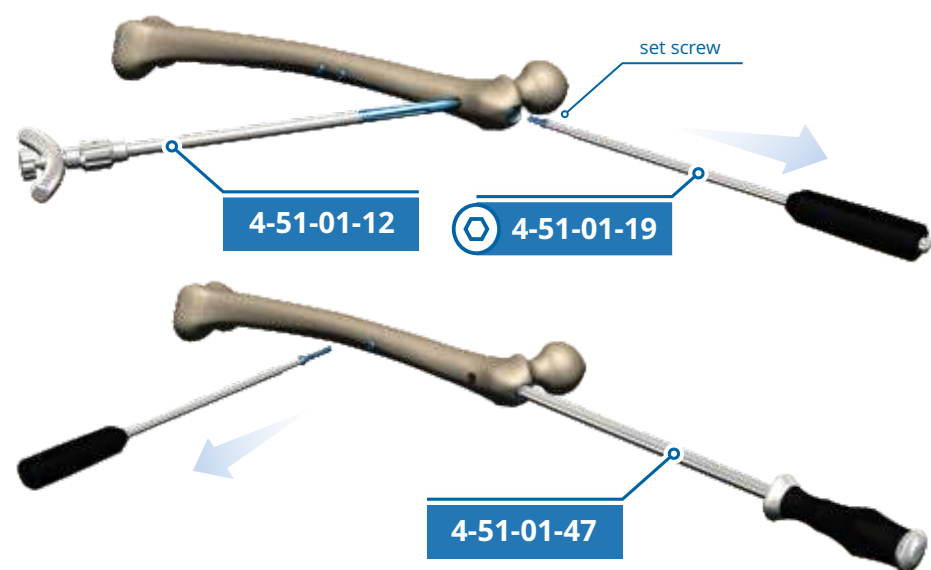

Install the extractor rod **4-51-01-47** on the nail and remove the locking screws.

03

Remove the nail using the hammer **4-51-01-16**.

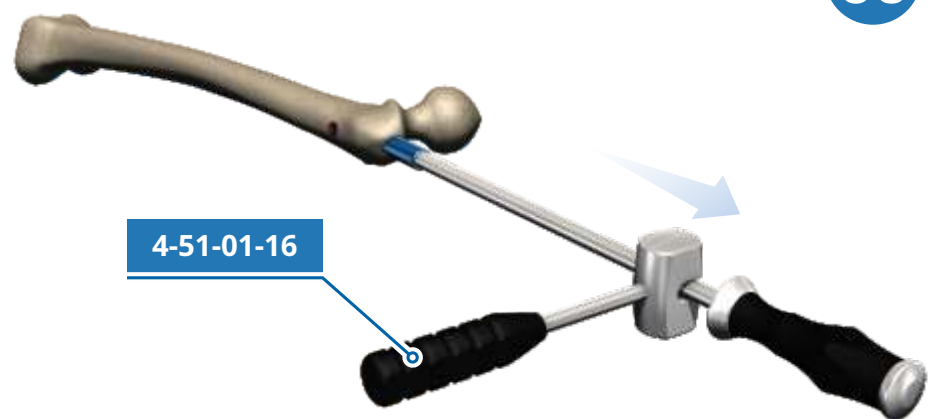



01

## REMOVAL OF THE NAIL WITH USE OF THE ANTI-ROTATION SCREW

Remove the locking screws.

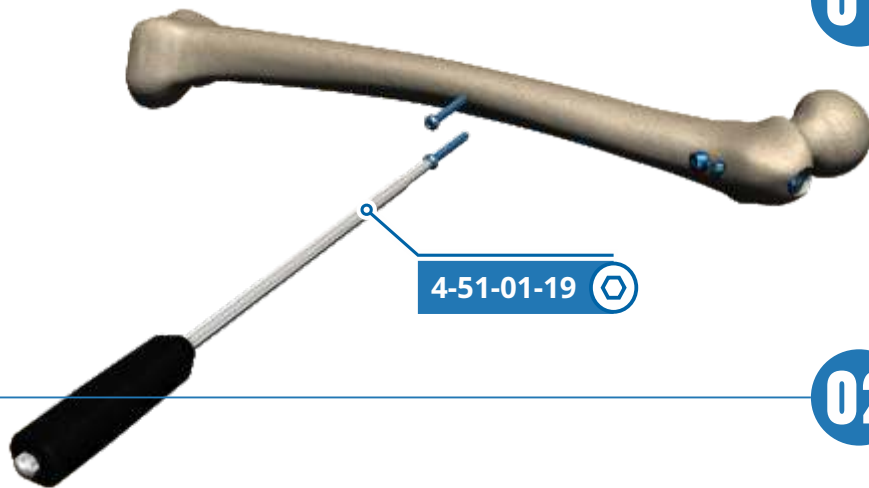

02

Remove the end cap from the lag screw.

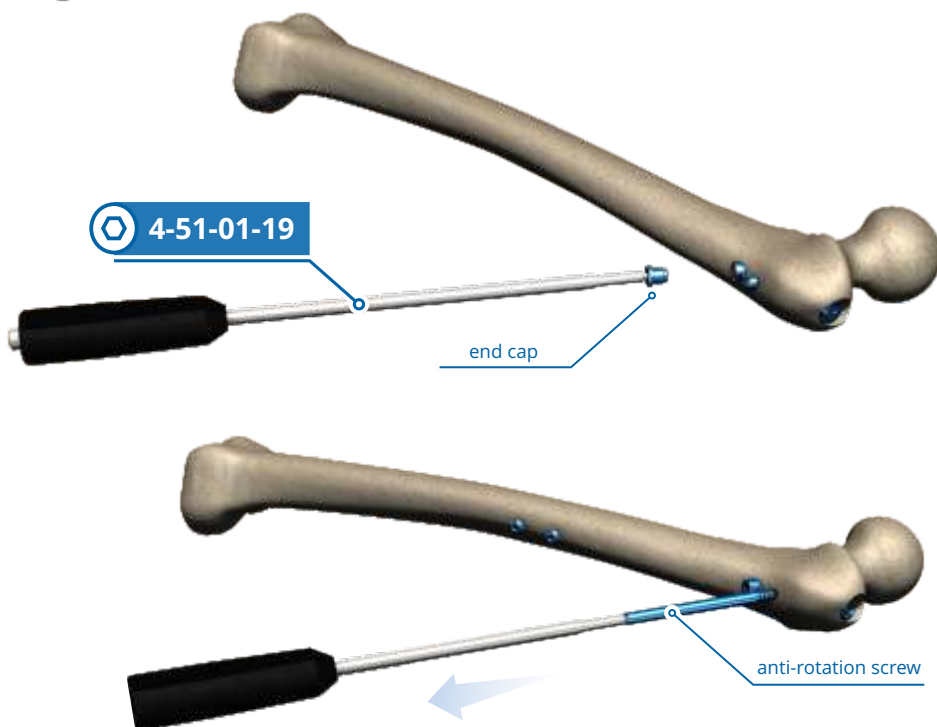

Then remove the anti-rotation screw.

### NOTE!

The end cap and the screw should be locked on the screwdriver  
**4-51-01-19 + 4-51-01-19.2**

03

Remove the end cap from the nail.

### NOTE!

The end cap should be locked on the screwdriver **4-51-01-19 + 4-51-01-19.2**.

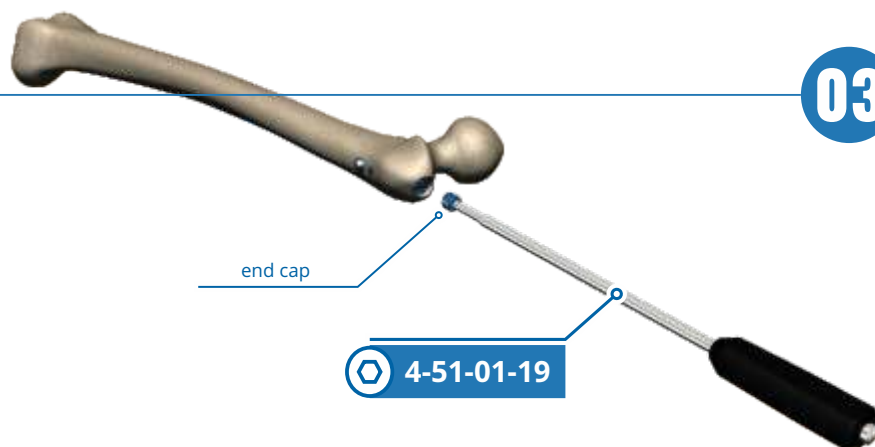

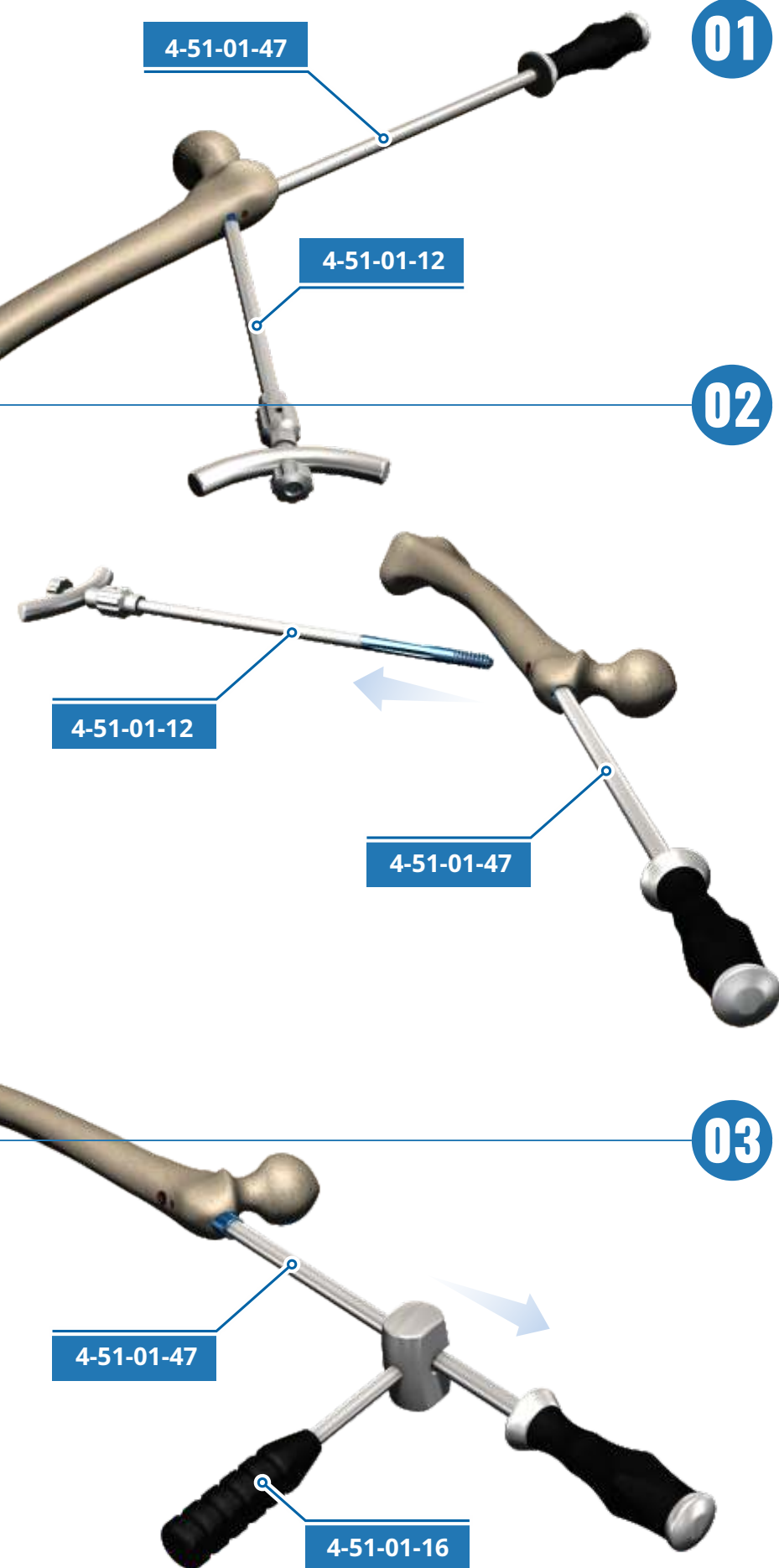

Install the extractor rod **4-51-01-47** on the nail.

Install the lag screwdriver **4-51-01-12** on the lag screw.

Remove the lag screw.

Remove the nail using the hammer **4-51-01-16** and the extractor rod **4-51-01-47**.



# **MEDGAL**<sup>®</sup>

ORTHOPAEDIC IMPLANTS & INSTRUMENTS

**MEDGAL**<sup>®</sup> Sp. z o.o.  
16-001 Księżyno (near Białystok)  
ul. Niewodnicka 26A

## **MARKETING i SALES DEPARTMENT**

info@medgal.com.pl  
phone: +48 85 6632 999

### **HEAD OFFICE**

phone: +48 85 6632 344  
fax+48 85 6632 622

