

1. General Description

1.1. Key Function

The brand PaX-i3D Smart(model named PHT-30LFO) is an advanced digital dental diagnostic system that provides 3D CT imaging, Panoramic, and Cephalometric imaging capabilities into one equipment securing the space efficiency and cost saving. Also, the revolutionary platform of PaX-i3D Smart provides a wide range of imaging option based on the customer's diagnostic needs. Its advanced digital imaging process allows for a considerably more efficient diagnosis, well-rounded management of information, and a real-time sharing of image information over a network.

- 3 in 1 – CBCT, Panoramic, Cephalometric
- 3D Pan & Real 2D by 1 scan
- Low dose Imaging
- CBCT FOV (unit : mm)
: 100x85 multi (100x85, 100x70)
- CEPH FOV (unit : inch)
 1. R-Troy(1210SGA) - One-Shot Premium (OP type)
: 12x10 multi (12x10, 9x10, 8x8)
 2. TOK-Troy(910SGA) – One-Shot Standard (OS type)
: 9x10 multi (9x10, 8x8)
- Superior Image Processing Algorithm
 - Magic PAN: a feature with an AF to acquire the sharper image, based on the principle of reconstruction through the optimal focal points to correct the improper patient positioning and rotating unit's trajectory (Optional)
 - MAR (Metal Artifact Reduction): the effects of metal artifact reduction, in order to acquire a much clearer image
- Supports DICOM format based on the governing international standards.



1.2. Product options

Option	Description	Remark
PaX-i3D Smart SP	Panoramic & CT	
PaX-i3D Smart SC	Panoramic, Cephalometric & CT	CEPH: Scan type
PaX-i3D Smart OS	Panoramic, Cephalometric & CT	CEPH: One shot type (TOK-Troy)
PaX-i3D Smart OP	Panoramic, Cephalometric & CT	CEPH: One shot type (R-Troy)

2. Functional Specification

2.1. PANORAMIC

2.1.1. Summary

PaX-i3D Smart conditionally offers 2 levels of panoramic imaging system.

Level	Imaging Option	Remark
Normal	Standard examination / Special Examination	Default
Magic Pan	Magic PAN function is applied in only Standard Examination.	Optional

2.1.2. Examination MODE & Scan Time

EXAMINATION	ARCH SELECTION	MODE	SCAN TIME (s)	
			HD	Normal/Fast
STANDARD EXAMINATION	Narrow	Standard	13.6	7.0
		Right	6.8	3.5
		Front	11.3	5.8
		Left	6.8	3.5
	Normal	Standard	13.6	7.0
		Right	6.8	3.5
		Front	11.3	5.8
		Left	6.8	3.5
	Wide	Standard	13.6	7.0
		Right	6.8	3.5
		Front	11.3	5.8
		Left	6.8	3.5
	Child	Standard	11.5	6.1
		Right	5.7	3.3
		Front	9.2	5.2
		Left	5.7	3.0

EXAMINATION	ARCH SELECTION	MODE	SCAN TIME (s)	
			HD	Normal/Fast
	Orthogonal	Standard	13.5	7.0
		Right	6.7	3.5
		Front	11.1	5.0
		Left	6.7	3.5
		Bitewing	11.3	11.3
		Bitewing Incisor	2.6	2.6
		Bitewing Right	4.9	4.9
		Bitewing Left	4.9	4.9
SPECIAL EXAMINATION	-	TMJ LAT Open	7.7	7.7
		TMJ LAT Close		
		TMJ PA Open	7.0	7.0
		TMJ PA Close		
		Sinus LAT	3.7	3.7
		Sinus PA	9.6	9.6

Panoramic Sample Image



[HD_Standard]

2.2. CEPHALOMETRIC

2.2.1. Examination Programs & Scan Time

<Scan type>

EXAMINATION PROGRAM	SCAN TIME (s)
Lateral	12.9
PA	12.9
SMV	12.9
Waters View	12.9
Carpus	12.9
Full Lateral (Optional)	16.9

Cephalometric sample image



[SC Lateral]



[SC PA]

2.3. CBCT

2.3.1. FOV & Examination Position

FOV Size	VERTICAL POSITION	HORIZONTAL POSITION			Remarks
		Right	Center	Left	
100x85 100x70	Occl	X	O	X	

** Full Arch Area capture only(Adult, Child mode)*

2.3.2. Scan Time

Mode	Low dose	Ultra low dose
Scan time	18 s	18 s
Exposure time	12 s	12 s

2.3.3. Reconstruction Time & File Size

FOV(mm)	Voxel Size	Reconstruction Time (s)	File Size (MB)	Remarks
100x70	0.2	75	202	*MAR skip
	0.3	75	60	
100x85	0.2	95	245	
	0.3	95	73	

** MAR: Metal Artifact Reduction*

***Image reconstruction time varies depending on computer specification and/or working condition.*

**** The above data is obtained from a computer system which is based on Lenovo Workstation Z420 and ZOTAC NVIDIA Geforce GTX 780 TI AMP! D5 3.0GB Graphic Card.*

***** Object : skull*

Computed Tomography(CT) sample image

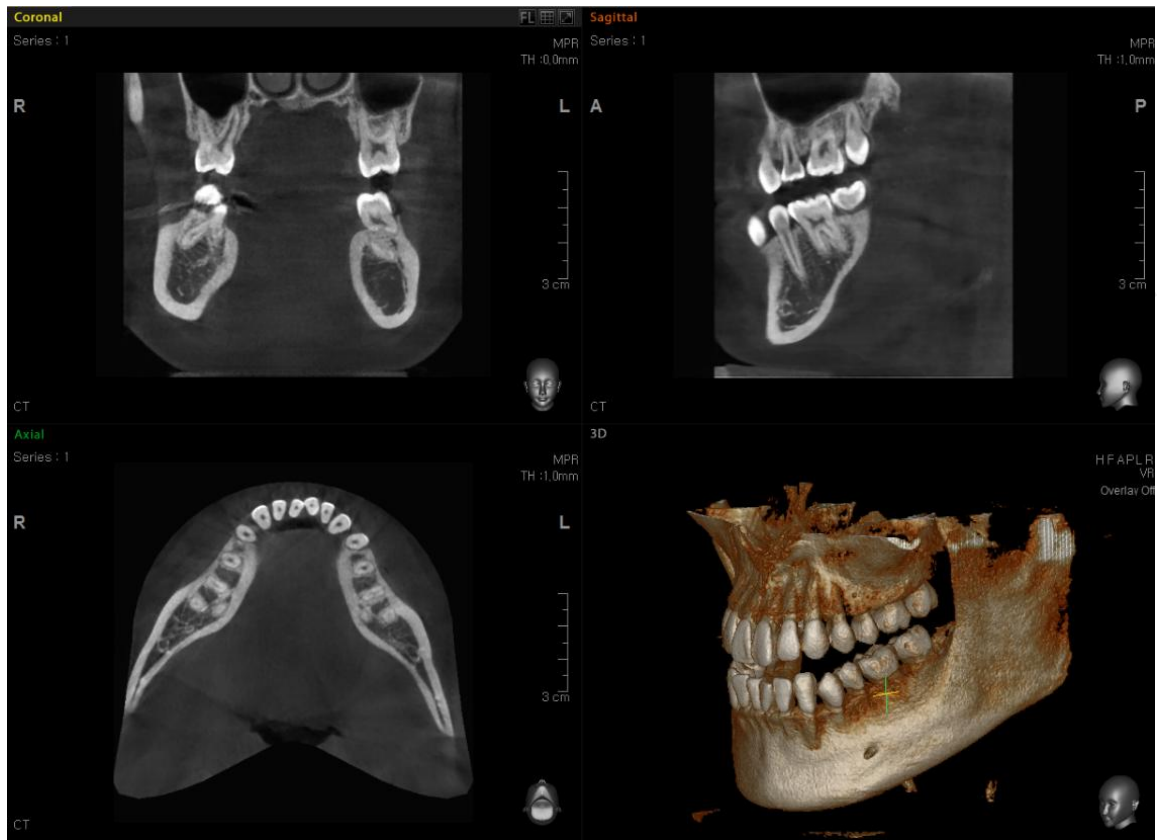

[Low dose: FOV 100 X 85_0.2 Voxel Image, MAR Skip]

CONFIDENTIAL

3. Recommended PC Specification

ITEM	HP	LENOVO
CPU	Intel Xeon E5-1607 3GHz 1600 4C or Faster	Intel Xeon E5-1607 3GHz 1066 or Faster
RAM	16GB DDR3-1600 ECC RAM	8GB DDR3 1600MHz UDIMM
Hard disk drive	1TB SATA 1st HDD	1TB SATA 1st HDD
Graphic board	ZOTAC NVIDIA Geforce GTX780 Ti AMP! D3 3GB	ZOTAC NVIDIA Geforce GTX780 Ti AMP! D3 3GB
Ethernet interface	Broadcom 5761 Gigabit Ethernet	Intel 82579 Gigabit Ethernet
Serial Port (RS232)	HP Serial Port Adapter kit	1(On Board)
Power supply	≥ 600 Watts (90% efficient)	≥ 610 Watts (85% efficient)
Slots	2 PCI Express Gen3 x16 slot 1 PCI Express Gen3 x8 Slot 1 PCI Express Gen2 x8 Slot 1 PCI Express Gen2 x4 Slot	2 PCI Express Gen3 x16 Slot, 1 PCI Express Gen3 x16 Slot(x4 Electrical) 1 PCI Express Gen2 x 4 Slot
	1 PCI Slot	1 PCI Slot
CD/DVD drive	DVD-ROM, DVD+/-RW, Blu-Ray	DVD-ROM DVD R/W, Blu-Ray R/W Multi-card reader
Monitor	19" 1280x1024 screen resolution	19" 1280x1024 screen resolution
Operating system	Windows 7 Professional 64-Bit OS	Windows 7 Professional 64-Bit OS
Recommended system	Z420	S30

** The specification above is highly recommended for proper image acquisition.*

4. Mechanical Specification

4.1. Image Magnification

Mode	FDD	FOD	ODD	magnification
CT	600 mm	428.57 mm	171.43 mm	1.4 constant
Panoramic	600 mm	428.57 mm	171.43 mm	1.4 constant
Cephalometric	1745 mm	1524 mm	221 mm	1.14 constant

* FDD : Focal Spot to Detector Distance

* FOD : Focal Spot to object Distance

* ODD : Object to Detector Distance ($ODD = FDD - FOD$)

* Magnification = FDD / FOD

4.2. Dimensions of Unit

Item	Description
Weight	without cephalometric unit
	Without base: 167 kg(368.2 lbs)
	With base: 220 kg(485 lbs)
	with cephalometric unit (SC type)
	Without base: 202kg(445.3 lbs)
	With base: 255kg(562.2 lbs)
Total height	Max. 2336 mm (92 inch)
Vertical column movement	Max. 700 mm (Max. 27.6 inch)
Length x Width x Height	without cephalometric unit
	1113 (L) x 1389(W) x 2336 (H) mm 43.8(L) x 54.7(W) x 92(H) inch
	with cephalometric unit (SC type)
	1882 (L) x 1400 (W) x 2336 (H) mm 74.1(L) x 55.1(W) x 92(H) inch
	with cephalometric unit (OS/OP type)
	1882 (L) x 1400 (W) x 2336 (H) mm 74.1(L) x 55.1(W) x 92(H) inch
Type of installation	Base Type / Non-Base Type(Wall Mount default)

Without cephalometric unit

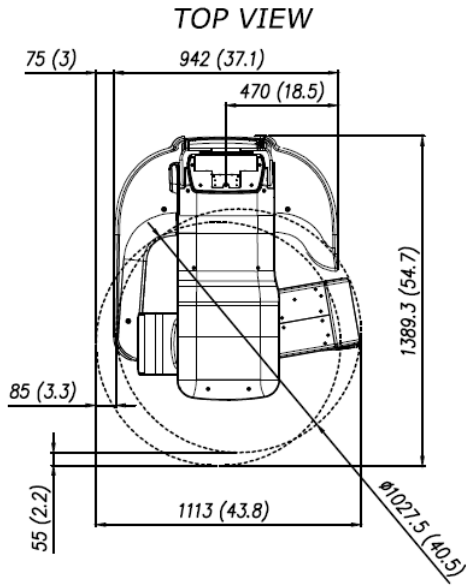

FRONT VIEW

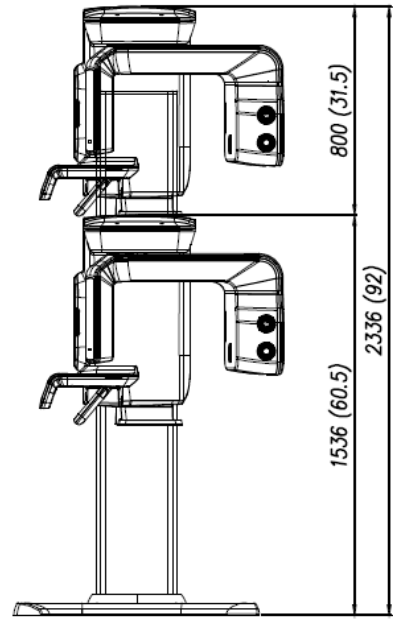

[Unit : mm(inch)]

CONFIDENTIAL

With cephalometric unit (SC type)

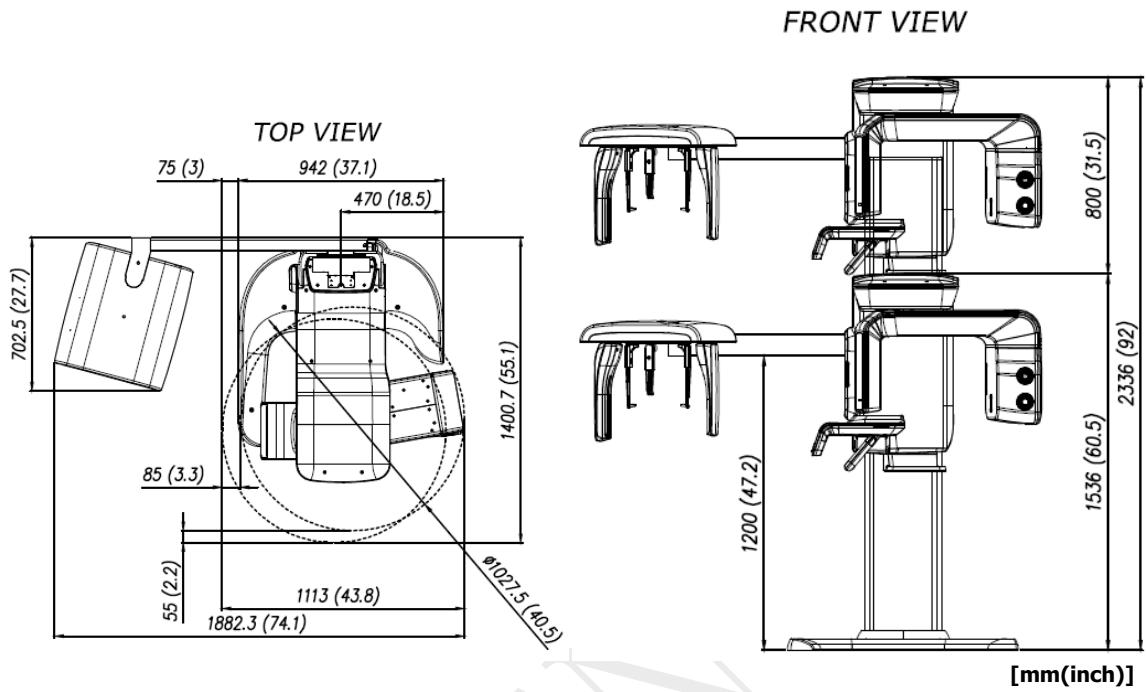

With cephalometric unit (OS/OP type)

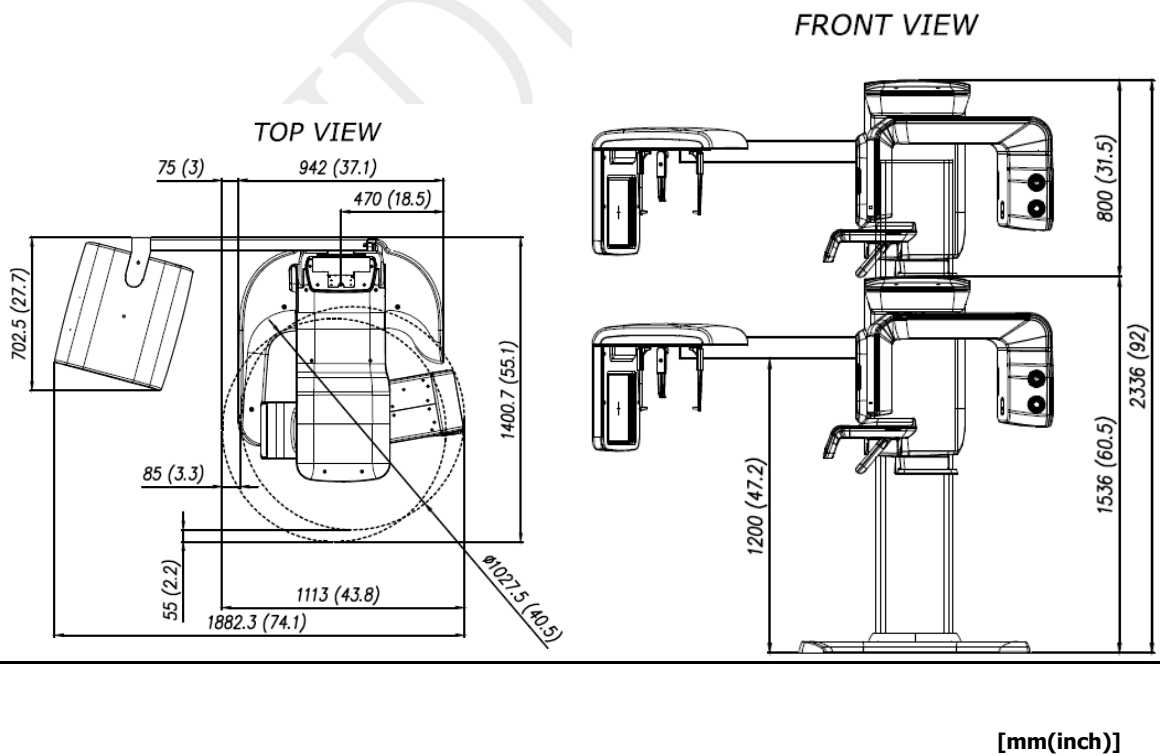

5. Technical specification

5.1. X-ray Generator(DG-07C11T2)

Item		Description	
Model		DG-07C11T2	
Rated output power		1.6 KW	
Generator Specification	Type	Inverter	
	Normal/ Pulse	kV	50 - 99 kV(Max. 99kV 10mA)
		mA	4 - 16 mA(Max 75kV 16mA)
	Cooling	Automatically controlled / Protect $\geq 60^{\circ}\text{C}$ Option: Cooling Pan	
	Total filtration	Min. 2.8 mm Al	
X-ray Tube	Manufacturer	Toshiba	
	Model	D-052SB (Stationary Anode type)	
	Focal spot size	0.5 mm (IEC60336)	
	Target Angle	5 degree	
	Inherent Filtration	At least 0.8mm Al equivalent at 50kV	
	X- ray Coverage	95x380mm at SID 550mm	
	Anode Heat Content	35 kJ	
	Duty Cycle	1:60 or more (Exposure time : interval time)	

5.2. Detector Specification

Item	Description			
	Panoramic/CT	Cephalometric		
Model	Xmaru 1404CF	Xmaru 2301CF	910SGA	1210SGA
Detector Type	CMOS photodiode array	CMOS photodiode array	Amorphous silicon TFT with scintillator	Amorphous silicon TFT with scintillator
Pixel size (μm)	49.5 99(2x2 binning) 198(4x4 binning)	100	127	127
Active area (mm)	135.8 x 36.4	5.9 x 230.4	222 x 254	264 x 325
Frame Rate	53.5 fps 107(2x2 binning) 308(4x4 binning)	200 fps	240 fps	240 fps
A/D(bit)	14	14	14	14
Sensor Size LxWxH(mm)	230 x 160 x 26	251.2 x 69 x 27.1	314 x 279 x 24	402 x 364 x 32

6. Electrical Characteristics

Item	Description
Power supply voltage	AC 100-240 V \pm 10%
Frequency	50/60 Hz
Power rating	2.2 kVA \pm 10%

* The input line voltage depends on the local electrical distribution system.

* Allowable input voltage fluctuation requirement: \pm 10%

7. Environmental Characteristics

Item	Description
Operating temperature	10 ~ 35°C
Operating relative humidity	30 ~ 75%
Operating atmospheric pressure	860 ~ 1060 hPa
Transport and storage temperature	-10 ~ 60°C
Transport and storage relative humidity	10 ~ 75%
Transport and storage atmospheric pressure	860 ~ 1060 hPa

8. Standards and Regulations

This product is designed and produced to meet the following standards:

IEC/EN/UL 60601-1, IEC/EN 60601-1-1, IEC/EN 60601-1-2, IEC/EN 60601-1-3,
IEC/EN 60601-2-7, IEC/EN 60601-2-28, IEC/EN 60601-2-32, IEC/EN 60601-2-44,
ISO 9001, ISO 13485



CE symbol grants the product compliance to the European Directive for Medical Devices 93/42/EEC as amended by 2007/47/EC as a class IIb device.

9. Additional Information

For additional information regarding any other products, please contact us by one of the following methods:

VATECH Company Limited

13, Samsung 1-ro 2-gil, Hwaseong-si, Gyeonggi-do, Korea (Postal Code: 445-170)

Tel: +82-1588-9510

Fax: +82-(0)31-286-3787

E-mail: gcs@vatech.co.kr

URL: <http://www.vatech.co.kr>

※ **The terms and conditions are subject to change at any time without previous notice.**

CONFIDENTIAL

VATECH RESERVES THE RIGHT TO CHANGE THE TERMS AND CONDITIONS OF THE DISTRIBUTION AND THESE TERMS AND CONDITIONS ARE SUBJECT TO CHANGE AT ANY TIME WITHOUT NOTICE. INFORMATION ON THIS PAGE IS THE CONFIDENTIAL PROPERTY OF VATECH. ANY UNAUTHORIZED DISTRIBUTION OR COPYING OF THIS PAGE IS STRICTLY PROHIBITED.