

# Nanjing Jingning Quality Inspection Company

## TEST REPORT

- 1.TEST DATE: January 6 th,2020
- 2.NUMBER OF SAMPLES TESTED: 50 PCS
- 3.APPLICABLE STANDARD: DIN933 Bolt, class -5.8 zinc plated 16x70 (156056)
- 4.INSPECTOR:LI JUN

### DIN933 Bolt, class -5.8 zinc plated 16x70 (156056)

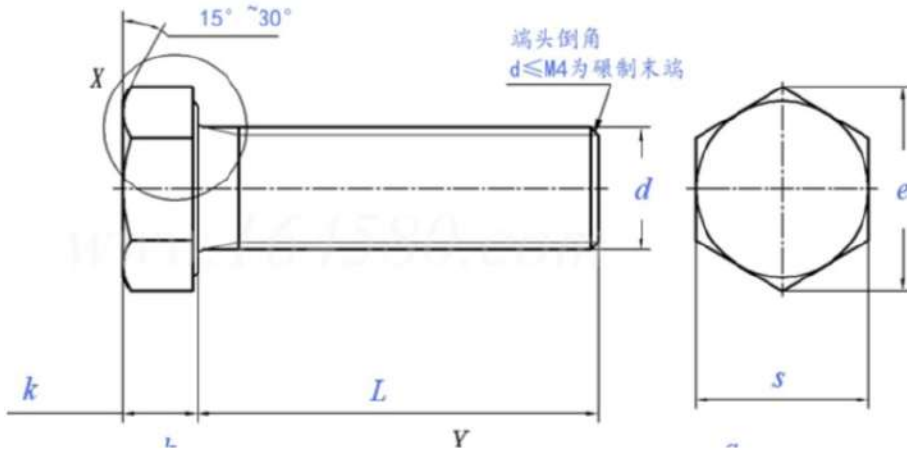

Items	d(mm)		k(mm)		s(mm)	
	Standard	Testing result	Standard	Testing result	Standard	Testing result
16x70	15.682-15.962	ACC	9.82-10	ACC	23.67-24	ACC

Items	Tensile Strength	
	Standard (kN)	Testing result
16x70	65.9	ACC

#### REMARK:

1.Test results are in accordance to the standard indicated.

2.ACC-Accept; REJ-Rejected

Material: Q195

Chemical composition & Technical specification

Element	C%	Si%	Mn%	P%	S%
16x70 Ratio	0.16~0.18	0.15~0.21	0.36~0.46	0.018~0.034	0.014~0.018

