



PROCESS INDUSTRIES /
TRANSPORTATION / ENERGY

CARBON BRUSHES
FOR MOTORS
AND GENERATORS



1

WHAT IS A CARBON BRUSH? **p.3**

2

CARBON BRUSH GRADES **p.9**

3

MAIN CARBON BRUSH SHAPES,
DIMENSIONS AND HARDWARE **p.18**

4

RECOMMENDATIONS FOR INSTALLING
CARBON BRUSHES IN MACHINES **p.22**

5

VISUAL GUIDE TO SLIP RING /
COMMUTATOR FILMS **p.24**

6

MERSEN'S SERVICES **p.29**

7

HOW TO ORDER CARBON BRUSHES? **p.31**

8

APPENDICES **p.32**

The specifications or data contained in present catalogue are only given for information and do not create any undertakings whatsoever. Any copy, reproduction or translation, either partially or fully, of these information is subject to the Mersen's prior written consent. In addition, due to the continuing improvement of techniques and change of applicable standards, Mersen is entitled to modify at any time the characteristics and specifications of its products as described in present catalogue.

WHAT IS A CARBON BRUSH?

(ALSO CALLED “MOTOR BRUSH”)

A carbon brush is a **sliding contact** used to transmit **electrical current** from a **static to a rotating part in a motor or generator**, and, as regards DC machines, ensuring a spark-free commutation.

A carbon brush can be:

- Made of one or more carbon blocks
- Equipped with one or more shunts / terminals

Five brush grade families are used for brush manufacturing. Each of them corresponds to a specific requirement and has its own production process (see pages 9 to 17 of this guide).

OPERATING PARAMETERS

The carbon brush plays an essential part in the operation of electrical machines. To enable it to fulfill its function, we need to consider three types of parameters:

- **Mechanical**
- **Electrical**
- **Physical and chemical (environment)**

Considering those parameters, together with technical information supplied by your teams, our experts will be able to select the most suitable carbon brush grade for your application. Our teams will also advise you how to optimize the parameters of your electrical machine and to improve the maintenance operations. This joint effort between your company and Mersen will contribute to the performance and longevity of your equipment.

For more information please refer to **Technical Data Sheet TDS-01***, “Functions of a good carbon brush, what you should know”.

Mechanical parameters

SLIP RING AND COMMUTATOR SURFACE CONDITIONS (ROUGHNESS)

A proper slip ring or commutator roughness will give the carbon brush an adequate seating base and will ensure a good current transmission (See **Technical Data Sheet TDS-02***). Slip ring and commutator surfaces must be neither too smooth (glossy), nor too rough to enable optimal carbon brush performance. High mica often creates serious problems for brushes. Commutators therefore have to be carefully checked (correct mica undercutting, absence of burrs along the bar edges) and the bar edges have to be properly chamfered (See **Technical Data Sheet TDS-03***).

It is also necessary to check that the commutator or slip ring run out does not exceed acceptable limits.

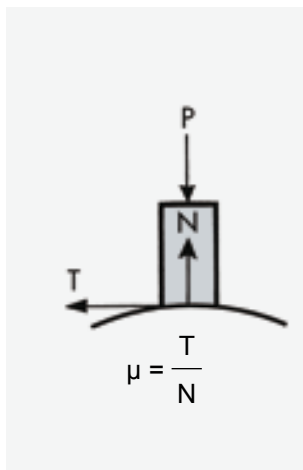

FRICITION COEFFICIENT (CALLED “μ”)

Carbon brush friction coefficient “μ” has to be low and stable over time to allow the carbon brush to work without overheating.

“μ” has no fixed value. It is the result of many factors depending upon the carbon brush grade, speed, load, commutator (or slip ring) condition and environment.

For a given carbon brush grade, it is not possible to indicate a precise “μ” value, only a magnitude. This is sufficient for most machine calculations or projects.

“μ” friction coefficient calculation formula

The “μ” friction coefficient is the relationship between T (tangential force due to friction) and N (normal force).

P is the pressure applied on the carbon brush.

VIBRATION

Excessive vibration reduces the quality of the carbon brush / commutator or carbon brush / slip ring contact, and therefore the overall performance of your equipment.

Vibration can be caused by:

- Poor machine balancing, defective bearings, incorrect alignment
- Commutators in poor condition (e.g. deformed)
- External components of the machine itself (gears, coupling, drive equipment, loads)
- Very high or fluctuating friction resulting from an unsuitable carbon brush grade, polluted atmosphere, extended periods of underload, or insufficient roughness (glazed surface)
- Moving machinery (locomotive, mine truck...)

Extreme vibration is likely to cause major brush damage as well as destruction of the brush-holder and associated commutator or slip ring. These incidents may be minimized, if not eliminated, by proper brush design and regular maintenance of the electrical machine.

CARBON BRUSH PRESSURE ON A SLIP RING OR COMMUTATOR

At any given machine speed, the spring pressure must be sufficient such that proper contact between the carbon brush and the slip ring / commutator is maintained. (See **Technical Data Sheet TDS-11***).

Mersen recommends:

- For stationary electrical machines: 180 - 250 g/cm² (2.56 - 3.56 psi)
- For electrical machines under heavy vibration (e.g. traction motors): 350 - 500 g/cm² (5.00 - 7.11 psi)

Equal spring pressure must be maintained for all carbon brushes to ensure a good current distribution. We therefore advise **periodic pressure measurement** with a scale or a load cell.



BRUSH-HOLDERS

The carbon brush has to be guided by a brush-holder of sufficient height and with an adequate clearance to avoid either the brush getting stuck or the brush rattling in the holder. Tolerances and clearances are set by the International Electrotechnical Commission (I.E.C.).

(See **Technical Data Sheet TDS-04***).

Electrical parameters

VOLTAGE DROP (OR CONTACT DROP)

The voltage drop has to be moderate to avoid overheating and abnormal electrical loss which can damage the sliding contact. It also influences commutation and current distribution in between the carbon brushes.

This is an important characteristic which depends on the carbon **brush grade**, **electrical contact** and **film** (which is a complex mix of metal oxides, carbon, and water, deposited on the slip ring or commutator).

It is therefore to be expected that the contact drop is influenced by all the factors which may modify the film:

- Room temperature, pressure and humidity
- Environmental impurities
- Commutator / slip ring speed
- Pressure applied on the carbon brushes
- Transverse current

The contact drop data indicated for each of the Mersen carbon brush grades are **typical values obtained in specific operating conditions**. They are grouped into five categories ranging from “extremely low” to “high” (see pages 13 to 15 of this guide).

COMMUTATION (DC MACHINES)

What is Commutation?

Commutation is the process of reversing the direction of the flow of current in the armature coils under the brush of a DC/AC commutator motor or generator. The time of commutation is the time taken for complete reversal.

Incorrect adjustment of the brush position relative to the neutral zone, or asymmetrical brush arm adjustment, can generate commutation sparking, which should not be confused with other types of sparking due to:

- Mechanical causes (vibration)
- Winding faults (open or short-circuit)
- Poor commutator construction
- Quality of the DC supply (ripple or spikes) from the electronic static converters...

Some solutions can help to improve commutation:

- **Multi wafer carbon brushes**
- **Dual grade composite carbon brushes** (with wafers made of different grades)
- **Sandwich brushes** (with two layers of the same grade), which limit cross currents, and have a positive influence on film control. The wafers are glued. (See **Technical Data Sheet TDS-07***)
- **Staggering carbon brushes**, adapted for large slow machines (See **Technical Data Sheet TDS-09***)

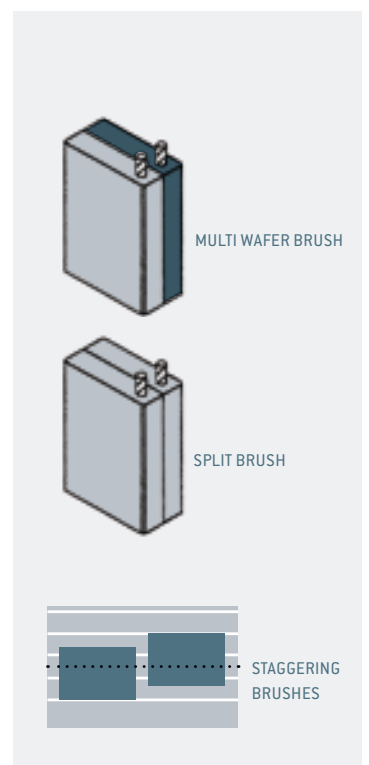
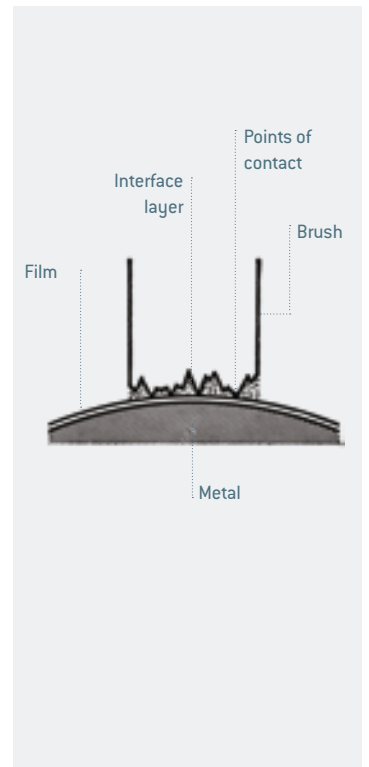



DISTRIBUTION OF CURRENT IN THE BRUSH CONTACT SURFACE

Current does not flow uniformly across the whole brush contact surface. It flows through a varying number of very small areas called contact spots. Ideally these contact spots are evenly distributed.

This balance may be disrupted when the contact spots concentrate and decrease in number. The film will then show signs of grooving, bar marking, streaking, and electrical erosion, deteriorating over time.

Various factors can cause this **imbalance**:

- External agents (dust, vapors, excessive humidity, temperature)
- Unsuitable brush grades for the operating conditions (film too thick, current density too high or low, poor ventilation...)
- Unequal spring pressures causing unequal current distribution between brushes of the same polarity on commutators and between brushes on the same slip ring

CURRENT DENSITY

What is current density?

This is the ratio of the current to the cross-sectional area of the brush. Its symbol is J_B .

$$J_B = \frac{I}{S \times N_p}$$

I = the armature or rotor current flowing through the machine (Amps)

S = carbon brush cross-sectional area (cm² or in²)

N_p = number of carbon brushes (half the number of carbon brushes for a DC machine) or number of carbon brushes per slip ring for a slip ring machine

Current density has a major influence on all aspects of brush performance: wear, friction, and temperature.

The maximum current densities for each grade are those at rated speed. They can vary, however, depending on the machine's characteristics and the ventilation method.

Please note that a low current density can be more harmful to the carbon brush and commutator / slip ring than a high current density (please contact us for more information).



NOTE

Resistivity values for brush grades indicated in this guide are measured along the radial direction (please refer to page 18 of this guide for the definition of the radial dimension).

RESISTIVITY

What is resistivity?

The resistivity of a material, usually symbolized by the Greek letter rho (ρ), represents its resistance to the flow of electrical current.

Higher resistivity materials increase the overall resistance in the commutation circuit, thereby improving commutation. It is a key parameter in the choice of the suitable carbon brush grade (please contact us for more information).

Multi wafer brushes, especially sandwich brushes, enable an artificial increase of transverse resistivity and can improve commutation.

Physical and chemical parameters (environment)

HUMIDITY

Water, the essential component of commutator or slip ring films, is supplied by ambient air. The film will form best in a humidity range of 8 to 15 g / m³ (0.008 to 0.015 oz/ft³) of air (See **Technical Data Sheet TDS-17***).

In very dry air, the film consists mostly of metal oxides, causing high friction and brush wear. These unfavorable conditions become critical when the absolute humidity rate falls below a threshold of 2 g / m³ (0.002 oz/ft³) of air.

This may be the case for:

- Aerospace and space industry, where machines are likely to operate in rarefied atmospheres at high altitudes
- Machines with brushes working in an enclosure filled with dry gas (hydrogen or nitrogen)
- Totally enclosed motors (IP 55)
- Desert or arctic environments (for example ski lifts)

Mersen proposes carbon brushes with special treatments for these particular applications. Do not hesitate to consult us.

CORROSIVE VAPORS OR GASES

Even when present in low concentrations, and especially in humid conditions, corrosive vapors or gases affect and destroy the contact film, damage the commutator (or the ring) and consequently the carbon brushes.

Examples of corrosive vapors or gases:

- Chlorine and its compounds (chlorate solvents)
- Ammonia
- Hydrogen sulphide
- Sulphur dioxide
- Products originating from hot distillation of silicones.

Mersen's treated brushes can help mitigate these problems by creating a protective film on the contact surface

OILS AND HYDROCARBONS

Commutators, slip rings and carbon brushes can get contaminated by oils and fats from various origins:

- Leaks from a bearing which is not properly sealed
- Tiny drops or mist carried by ventilating air
- Vapor condensation (developed at hot points)

These oily contaminations disturb the operation of carbon brushes in electrical machines, leading to the:

- Immobilization of brushes in their holders by the sticky mixture of oil and carbon dust
- Deterioration of slip rings, commutators and brush performance as a result of thick insulating films on the contact surfaces





DUST

The more abrasive the dust, the more harmful it is. Dust causes:

- Grooving of commutators and slip rings
- High brush wear
- Carbon brush side gulling (see picture opposite), with brushes sticking in their holders
- Pollution of machines

Dust grooves partly avoid these problems, but the best remedy is prevention, providing clean filtered air to the machines.

In totally enclosed machines, where carbon dust is continuously recirculated, the same problems are likely to arise, with the possibility of polluting the machine and decreasing its insulation resistance. These machines should be cleaned regularly.

Mersen designed and patented the DustCollector, a modular carbon dust collection system extracting dust at its source to refrain it from dispersing all over the machine (see box below).

DUSTCOLLECTOR, A NEW INNOVATION PATENTED BY MERSEN

Dust extraction system integral to the brush-holder

- No generator modification required
- Simple installation
- Standard product that can be customized
- A complete solution
- For original equipment or retrofit

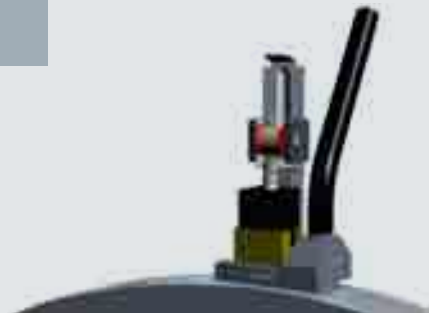

Mersen is well aware of how vital it is to control these process parameters, and can propose maintenance services, in particular in situ diagnostics and recommendations on your machines.

See page 29 of this guide.

As stated in this guide's introduction, there are five main brush grade families, each with a distinct set of properties. Some of these groups are complemented by a subgroup of impregnated brush materials (please consult us to find out more about the specific properties of those special materials).

The choice of the most suited brush grade depends on a large number of parameters linked to the machine itself as well as its environment. Choosing the brush grade that performs best for a specific application requires an in-depth knowledge of its working environment. Mersen therefore recommends contacting our experts for assistance with your specific needs.

Mersen has developed a **wide range of brush grades** able to meet even the most demanding requirements.

Hereafter, you will find a description of the manufacturing process of our main grade families, as well as a table with their material properties (see table pages 14 and 15). You will find on pages 16 and 17 a summary of the major applications together with the operating limitations of most of the grade families (based on our usual conventions reminded page 13).

GRADE FAMILIES

EG. Electrographitic brushes

How are our electrographitic brush materials manufactured?

Electrographitic materials are carbographitic materials that are graphitized at temperatures in excess of 2,500°C in order to transform basic amorphous carbon into artificial graphite.

MAIN CHARACTERISTICS

Electrographitic brushes have a medium contact drop and a low to medium friction coefficient, and therefore have low electrical loss, particularly suited to high peripheral speeds (≤ 50 m/s). The graphitization process yields a high strength, low resistance material, particularly resistant to high temperatures.

MAIN APPLICATIONS

- All DC stationary or traction industrial machines, operating with low, medium or high voltage and constant or variable loads. They are also found on AC synchronous and asynchronous slip ring applications.

OPERATING LIMITATIONS

- Current density in the brushes:
 - 8 to 12 A/cm² (50 to 75 A/in²) under steady conditions
 - 20 to 25 A/cm² (130 to 160 A/in²) for peak loads
- Maximum peripheral speed: 50 m/s (154 ft/s).



A. Carbographitic brushes

How are our carbographitic brush materials manufactured?

They are made from a mixture of coke and graphite powders, agglomerated with pitch or resin. This powder is molded into blocks which are baked at high temperature to convert the binder into coke. These materials are not graphitized.

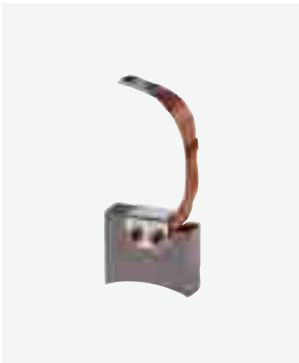

MAIN CHARACTERISTICS

Carbographitic brushes commutate well due to their high resistance and provide good polishing action, while maintaining moderate contact drop. As a result of their high temperature treatment, carbographitic brushes can withstand both high temperatures and variable loads.

MAIN APPLICATIONS

- Machines with an older design, mostly characterized by a slow speed, lack of interpoles, generally operating at low voltage
- Modern small machines, operating with permanent magnets, servomotors, and universal motors
- Low voltage battery powered motors

OPERATING LIMITATIONS

- Current density in the brushes: 8 to 12 A/cm² (50 to 75 A/in²) depending on the application
- Maximum peripheral speed: 25 m/s (82 ft/s)

LFC. Soft graphite brushes (LFC = Low Friction Coefficient)

How are soft graphite brush materials manufactured?

The main ingredients are purified natural graphite and artificial graphite, mixed with additives, agglomerated with appropriate binders, and treated at a high temperature to carbonize the binder.



MAIN CHARACTERISTICS

LFC brushes have a low Shore hardness with excellent shock absorbing properties. This allows them to work in applications where other materials would fail. They excel at high peripheral speeds which amplify the mechanical stresses associated with friction, vibration, air flow, run out, and heat.

MAIN APPLICATIONS

- Steel and stainless steel slip rings for synchronous machines

OPERATING LIMITATIONS

- Current density in the carbon brushes: 10 to 13 A/cm² (71 to 84 A/in²)
- Maximum peripheral speed: up to 100 m/s (328 ft/s)

OVERVIEW OF THE MANUFACTURE OF ELECTROGRAPHITE

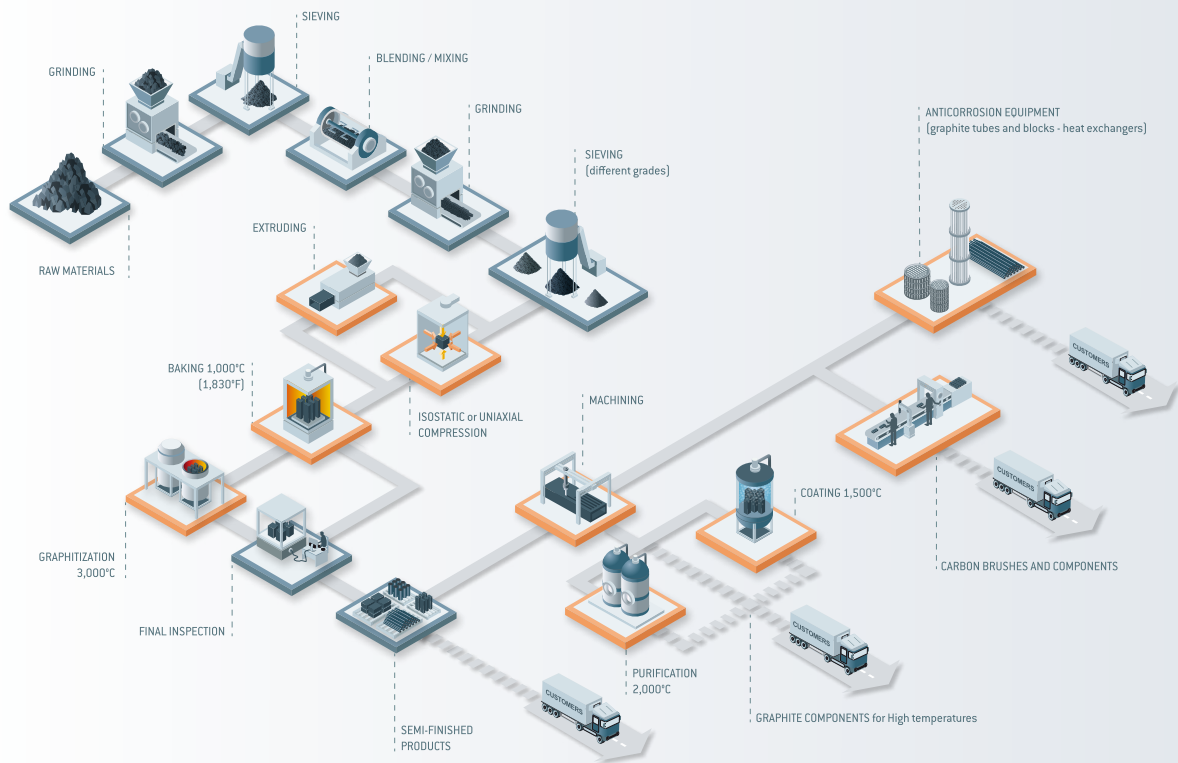

BG. Resin-bonded (bakelite graphite) brushes

How are resin-bonded brush grades manufactured?
 Powdered natural or artificial graphite is mixed with a thermo-setting resin. The mix is then pressed and polymerized at a suitable temperature.

MAIN CHARACTERISTICS

Carbon brushes with high to very high electrical resistance, contact drop, electrical loss, and mechanical strength, which have very good commutating and cleaning properties. They can also work at very low current densities.

MAIN APPLICATIONS

- AC Schrage-type commutator motors
- Medium-speed DC machines at medium voltage

OPERATING LIMITATIONS

- Resin-bonded grades should not be used at higher than rated current
- Admissible peripheral speed: 40 m/s (131 ft/s)



CG-MC-CA. Metal-graphite brushes

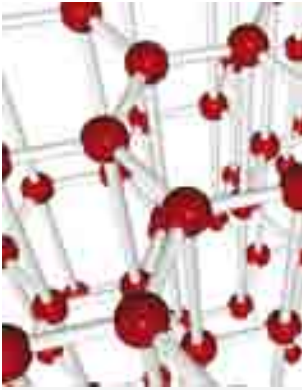

How are metal-graphite brush grades manufactured?

Powdered natural or artificial graphite is mixed with a thermo-setting resin, copper powder, and/or other metal powders. The mix is then pressed and polymerized at a suitable temperature in an inert atmosphere.

These metal-graphite materials also include EG and A carbon brushes that are metal-impregnated (see metal-impregnated brush grades on page 15).

MAIN CHARACTERISTICS

Dense to very dense carbon brushes with low friction and very low contact drop, therefore operating with very low losses and high currents.

■ (CG) COPPER-BASED BRUSH GRADES

MAIN APPLICATIONS

- Low-speed, low voltage DC machines
- Medium-speed, highly-loaded AC asynchronous machines (wind turbine generators)
- Medium-speed AC synchronous motors slip rings
- High current collection systems (electrolytic treatment lines, wire annealers, galvanizing lines...)
- Low-voltage current collection (military, medical, paramedical, signal...)
- Special machines
- Slip ring assemblies in rotary joints

OPERATING LIMITATIONS

- Current density:
 - 10 to 30 A/cm² (75 to 200 A/in²) under steady conditions
 - Up to 100 A/cm² (660 A/in²) for peak loads, depending on metal content
- Peripheral speed: up to 40 m/s (131 ft/s), depending on metal content

■ (CA/SG) SILVER-BASED BRUSH GRADES:

Silver grades have a higher conductivity than copper grades and form a special low resistance film due to the conductivity of silver oxide. Silver grades can also transfer low voltage current signals without degradation.

MAIN APPLICATIONS

- Signal current transmission (thermocouples, thermometric sensors, regulation...)
- Pulse transmission to rotating devices (radar, prospecting...)
- Tachometer generators
- Aerospace and space applications
- Shaft grounding in a dual-grade construction

OPERATING LIMITATIONS

- Current density up to 50 A/cm² (440 A/in²).
- Peripheral speed: up to 30 m/s (98 ft/s)

CONSOLIDATION OF CARBON BRUSH GRADES

An increasing number of companies wish to reduce the number of brush grades and carbon brush types they currently use. Mersen will assist in meeting these expectations. For many simple applications, this is quite easy as many different brush grades will perform well.

Difficult machines, however, will require careful preliminary examination. Mersen therefore recommends that our customers contact the Customer Technical Assistance to correctly select the brush grade to be used for each specific case.

Our Customer Technical Assistance Service is at your disposal for any question

Phone: +33 (0)3 22 54 44 90 E-mail: infos.amiens@mersen.com

Mersen is present in over 40 countries around the world; our branches are also at your disposal for local technical assistance. You can reach our worldwide network through our website at www.mersen.com

DETAILS ON CONTACT DROP AND FRICTION (SEE TABLES FOLLOWING PAGES)

The contact drop and friction values are given in the following table:

SYMBOL	SIGNIFICATION	CONTACT DROP (SUM OF BOTH POLARITIES)	FRICTION μ
E	HIGH	> 3 V	$\mu > 0.20$
M	MEDIUM	2.3 V - 3 V	$0.12 < \mu < 0.20$
B	LOW	1.4 V - 2.3 V	$\mu < 0.12$
TB	VERY LOW	0.5 V - 1.4 V	
EB	EXTREMELY LOW	< 0.5 V	

The contact drop and friction values were measured on a copper commutator in the following laboratory conditions:

ELEMENTS	CONTACT DROP	FRICTION μ
CURRENT TYPE	DC	DC
CURRENT DENSITY	10 A/cm ² (130 A/in ²)	10 A/cm ² (130 A/in ²)
SPEED	12.5 m/s (41 ft/s)	25 m/s (82 ft/s)
SPRING PRESSURE	18 kPa (2.6 PSI)	18 kPa (2.6 PSI)
TEMPERATURE	65-70°C (149-158°F)	65-70°C (149-158°F)
BRUSH TYPE	RADIAL	RADIAL

The current density and peripheral speed operating conditions were derived from observations on actual machines in good working order and operating in normal conditions.



BRUSH GRADE GROUPS MAIN CHARACTERISTICS (ACCORDING TO IEC NORM 60413)

BRUSH GRADE GROUPS	GRADES	APPARENT DENSITY*	RESISTIVITY $\Omega \cdot \text{cm}$ [$\Omega \cdot \text{in}$]	SHORE HARDNESS	FLEXURAL STRENGTH* MPA (PSI)	CONTACT DROP	FRIC-TION	OPTIMUM CURRENT DENSITY A/cm^2 [A/in^2]	RECOM-MENDED UPPER SPEED m/s [ft/s]	METAL CONTENT %
EG - ELECTRO-GRAPHITIC	EG34D	1.60	1,100 (433)	40	25 (3,626)	M	M	6 TO 12 (40 TO 77)	50 (164)	/
	EG389P	1.49	1,600 (630)	29	19 (2,756)	M	M	6 TO 12 (40 TO 77)	50 (164)	/
	L1	1.61	1,270 (500)	35	21 (3,046)	M	M	6 TO 12 (40 TO 77)	60 (197)	/
	EG362	1.60	2,500 (984)	35	21 (3,046)	M	M	6 TO 12 (40 TO 77)	50 (164)	/
	EG40P	1.62	3,200 (1,260)	57	27 (3,916)	M	M	8 TO 12 (50 TO 77)	50 (164)	/
	EG313	1.66	5,000 (1,968)	50	21 (3,046)	M	L	8 TO 12 (50 TO 77)	50 (164)	/
	EG367	1.53	4,100 (1,614)	52	21 (3,046)	M	M	8 TO 12 (50 TO 77)	50 (164)	/
	EG387	1.60	3,500 (1,378)	60	31 (4,496)	M	M	8 TO 12 (50 TO 77)	50 (164)	/
	EG300H	1.57	4,100 (1,614)	60	26 (3,771)	M	L/M	8 TO 12 (50 TO 77)	50 (164)	/
	2192	1.56	5,100 (2,008)	55	23 (3,336)	M	M	8 TO 12 (50 TO 77)	50 (164)	/
	CB377	1.71	6,350 (2,500)	75	29 (4,206)	H	L	8 TO 12 (50 TO 77)	40 (131)	/
	EG319P	1.46	7,200 (2,835)	52	26 (3,771)	H	M	8 TO 12 (50 TO 77)	50 (164)	/
	EG365	1.62	5,300 (2,087)	40	15 (2,176)	M	M	8 TO 12 (50 TO 77)	50 (164)	/
IMPREGNATED ELECTROGRAPHITIC	EG7099	1.72	1,100 (433)	40	34 (4,931)	M	M	6 TO 12 (40 TO 77)	45 (148)	/
	EG9599	1.61	1,600 (630)	33	28 (4,061)	M	M	6 TO 12 (40 TO 77)	45 (148)	/
	EG9117	1.69	3,300 (1,299)	77	36 (5,221)	M	M	8 TO 12 (50 TO 77)	50 (164)	/
	EG8019	1.77	4,700 (1,850)	77	31 (4,496)	M	M	8 TO 12 (50 TO 77)	45 (148)	/
	CB86	1.64	4,830 (1,902)	65	29 (4,206)	M	M	8 TO 12 (50 TO 77)	50 (164)	/
	2189	1.63	6,100 (2,401)	60	32 (4,641)	M	M	8 TO 12 (50 TO 77)	50 (164)	/
	510	1.44	7,100 (2,795)	45	17 (2,466)	M	M	8 TO 12 (50 TO 77)	50 (164)	/
	535	1.53	7,100 (2,795)	55	26 (3,771)	M	M	8 TO 12 (50 TO 77)	50 (164)	/
	EG8067	1.67	3,900 (1,535)	77	36 (5,221)	M	M	8 TO 12 (50 TO 77)	45 (148)	/
	AC137	1.72	5,100 (2,008)	80	41 (5,947)	M	M	8 TO 12 (50 TO 77)	50 (164)	/
	168	1.58	7,100 (2,795)	65	36 (5,221)	M	M	8 TO 12 (50 TO 77)	50 (164)	/
	EG8220	1.82	5,300 (2,087)	85	37 (5,366)	M	M	8 TO 12 (50 TO 77)	50 (164)	/
	EG7097	1.68	4,000 (1,575)	80	35 (5,076)	M	M	8 TO 12 (50 TO 77)	50 (164)	/
	EG341	1.57	7,200 (2,835)	74	34 (4,931)	H	M	8 TO 12 (50 TO 77)	50 (164)	/
	EG7655	1.70	5,600 (2,205)	68	33 (4,786)	M	M	8 TO 12 (50 TO 77)	50 (164)	/
EG6754	1.76	4,150 (1,634)	87	40 (5,802)	M	M	8 TO 12 (50 TO 77)	50 (164)	/	
A - CARBOGRAPHITIC	A121	1.75	2,250 (886)	30	26 (3,771)	M	L	8 TO 12 (50 TO 77)	25 (82)	/
	A176	1.60	52,500 (20,669)	40	20 (2,901)	H	L	8 TO 12 (50 TO 77)	25 (82)	/
	A252	1.57	45,000 (17,716)	27	16 (2,321)	H	L	8 TO 12 (50 TO 77)	25 (82)	/
	M44A	1.64	3,050 (1,201)	50	26 (3,771)	M	M	8 TO 12 (50 TO 77)	25 (82)	/

* Above values are indicative target values.

The specifications or data contained in present catalogue are only given for information and do not create any undertakings whatsoever.

BRUSH GRADE GROUPS MAIN CHARACTERISTICS (ACCORDING TO IEC NORM 60413)

BRUSH GRADE GROUPS	GRADES	APPARENT DENSITY*	RESISTIVITY $\Omega \cdot \text{cm}$ [$\Omega \cdot \text{in}$]	SHORE HARDNESS	FLEXURAL STRENGTH* MPA (PSI)	CONTACT DROP	FRIC-TION	OPTIMUM CURRENT DENSITY A/cm^2 [A/in^2]	RECOM-MENDED UPPER SPEED m/s [ft/s]	METAL CONTENT %
LFC - SOFT GRAPHITE BRUSHES	LFC501	1.46	1,900 (748)	10	8 (1,160)	M	L	6 TO 10 (40 TO 65)	75 (246)	/
	LFC554	1.26	2,000 (787)	12	11 (1,595)	M	L	11 TO 13 (71 TO 84)	100 (328)	/
BG - RESIN-GRAPHITE	BG412	1.82	13,800(5,433)	/	36 (5,221)	H	M	8 TO 10 (51 TO 65)	35 (115)	/
	BG469	1.80	9,450(3,720)	/	35 (5,076)	H	M	6 TO 8 (40 TO 50)	35 (115)	/
	BG348	1.50	25,500 (10,039)	/	25 (3,626)	H	M	8 TO 10 (51 TO 65)	40 (131)	/
CG - MC - METAL-GRAPHITE COPPER AGGLOMERATED	CG958	2.50	350 (138)	/	30 (4,351)	VL	M	10 TO 25 (65 TO 220)	40 (131)	25
	C7788	2.80	300 (118)	/	25 (3,626)	M	M	12 TO 20 (75 TO 125)	35 (115)	43
	CG651	2.95	130 (51)	/	30 (4,351)	VL	L	10 TO 14 (65 TO 90)	35 (115)	49
	CG626	2.88	180 (71)	/	45 (6,527)	VL	L	12 TO 18 (75 TO 112)	35 (115)	49
	CG607	3.60	31 (12)	/	51 (7,397)	VL	M	12 TO 18 (75 TO 112)	30 (98)	60
	CG657	4.00	30 (12)	/	65 (9,427)	VL	M	12 TO 20 (75 TO 125)	30 (98)	65
	CG677	4.00	20 (8)	/	65 (9,427)	VL	M	12 TO 20 (75 TO 125)	30 (98)	67
	CG757	4.50	35 (14)	/	45 (6,527)	VL	M	15 TO 25 (100 TO 220)	25 (82)	75
	MC79P	5.15	8 (3)	/	85 (12,328)	EL	L/M	20 TO 30 (129 TO 194)	20 (66)	83
	CG957	5.45	40 (16)	/	110 (15,964)	EL	M	20 TO 30 (129 TO 194)	20 (66)	87
MC877	5.40	12 (5)	/	85 (12,328)	EL	M	20 TO 30 (129 TO 194)	20 (66)	87	
MC837	5.50	15 (6)	/	70 (10,152)	EL	M	20 TO 30 (129 TO 194)	30 (98)	87	
CA - METAL-GRAPHITE SILVER AGGLOMERATED	CA38	2.55	250 (98)	/	10 (1,450)	EL	M	**	25 (82)	33
	CA26	3.60	20 (8)	/	40 (5,802)	EL	M	**	20 (66)	60
	CA28	4.00	40 (16)	/	45 (6,527)	EL	M	20 TO 30 (129 TO 194)	20 (66)	65
	CA10	8.00	6.5 (3)	/	160 (23,206)	EL	M	**	15	93
METAL-GRAPHITE METAL IMPREGNATED	M9020	1.75	2,700 (1,063)	68	37 (5,366)	L	M	12 TO 15 (75 TO 100)	45 (148)	5
	M673	1.72	1,180 (465)	35	26 (3,771)	EL	H	10 TO 12 (65 TO 75)	40 (131)	5.5
	M9426	1.62	1,775 (699)	24	20 (2,901)	VL	M	12 TO 15 (75 TO 100)	30/45 (98/148)	9
	M8295	1.80	1,775 (699)	54	34 (4,931)	VL	M	12 TO 15 (75 TO 100)	30/45 (98/148)	9
	M621	3.00	400 (157)	34	35 (5,076)	EL	M	40 (267)	40 (131)	44
	M609	2.65	310 (122)	35	33 (4,786)	VL/EL	EL	12 TO 15 (75 TO 100)	35 (115)	45
	MA7696	3.00	250 (98)	/	33 (4,786)	VL	M	12 TO 15 (75 TO 100)	35 (115)	55

Note : 1 MPa = 10 daN/cm² et 1 kPa = 10 cN/cm².

* Above values are indicative target values.

** Please consult us (mA low current)

The specifications or data contained in present catalogue are only given for information and do not create any undertakings whatsoever.



Never mix different brush grades on a slip ring or commutator.

GRADE SELECTION BASED ON APPLICATION

Mersen has developed a wide range of carbon grades to meet even the most demanding applications. We recommend that our customers contact the Customer Technical Assistance to correctly select the most suitable grade for each specific application.

The tables below detail brush grades most suited for different applications and operating conditions (current density, peripheral speed and applied brush pressure).

For each machine group, the most common brush grades are listed.

The order of the brush grades in the table does not imply a ranking of their performance.

Stationary commutator machines

TYPE OF CURRENT / APPLICATION	CURRENT DENSITY A/cm ² [A/in ²]	SPEED m/s [ft/s]	PRESSURE kPa [PSI]	BRUSH GRADES
DIRECT CURRENT				
Old machines without interpoles				
All motors	6 [40]	15 [49]	18 [2.6]	EG40P - A176 - EG34D
Low voltage machines (any power)				
Marine turbo-alternator exciters 30 to 50 V	4 - 8 [25 - 50]	25 [82]	18 [2.6]	LFC3H - EG7099 - CG651 - A121
Welding group generators 30 to 50 V	0 - 20 [0 - 125]	< 20 [< 65]	18 [2.6]	EG389P - EG367 - EG313
Industrial machines (110 - 750 V)				
Motors for general applications (high speeds)	8 - 12 [51 - 77]	20 - 45 [65 - 148]	18 [2.6]	EG34D - EG313 - EG367 - EG389P
Hydro turbo-alternator exciters	8 - 12 [51 - 77]	< 20 [< 65]	18 [2.6]	EG34D - EG7099 - EG389P EG9599 - EG365
Thermal turbo-alternator exciters	8 - 10 [51 - 65]	35 - 50 [115 - 164]	18 [2.6]	EG367 - EG365 - EG9599 - EG389P
Pilot exciters	2 - 5 [13 - 33]	< 35 [< 115]	18 [2.6]	EG34D - EG389P - BG469
Amplidynes	4 - 12 [25 - 77]	25 [82]	18 [2.6]	EG34D - EG389P
Illgner and Ward Leonard generators (any speed)	4 - 12 [25 - 77]	20 - 35 [65 - 115]	18 [2.6]	EG389P - EG367 - EG313
Paper mill motors and generators	4 - 12 [25 - 77]	35 [115]	18 [2.6]	EG34D - EG9599 - EG7099 - EG34D EG389P - BG469 - EG313 - 168
Marine generators	4 - 12 [25 - 77]	20 - 35 [65 - 115]	18 [2.6]	EG34D - EG389P - EG7099 - EG313
Rolling mill reversing motors	8 - 20 [51 - 125]	0 - 15 [0 - 49]	18 [2.6]	EG319P - EG369 - EG313 - 2192 - 535 - 510
Rolling mill roughing motors	8 - 15 [51 - 100]	20 - 35 [65 - 115]	18 [2.6]	EG389P - EG40P - EG319P - EG6489 EG313 - EG365 - 2192 - CB86
Mine winder motors	12 [77]	25 [82]	18 [2.6]	EG313 - EG365 - EG367 - CB377
Totally enclosed motors	10-12 [65 - 77]		18 [2.6]	EG9117 - EG8067 - EG7593
ALTERNATING CURRENT				
Single phase and repulsion motors	8 [51]	5 - 15 [16 - 49]	18 [2.6]	A252 - EG367
Schrage-type three-phase motors	8 - 12 [51 - 77]	5 - 35 [16 - 115]	18 [2.6]	BG412 - BG469 - BG348 - EG367
Schorch-type three-phase motors	10 - 14 [65 - 90]	5 - 35 [16 - 115]	18 [2.6]	BG28 - BG469 - EG367 - BG348
Scherbius machines	7 - 9 [45 - 58]	30 [98]	18 [2.6]	EG389P - EG313 - LFC554 - EG362

Traction commutator machines

TYPE OF CURRENT / APPLICATION	CURRENT DENSITY A/cm ² (A/in ²)	SPEED m/s (ft/s)	PRESSURE kPa (PSI)	BRUSH GRADES
DIRECT CURRENT				
Light traction				
All motors	8 - 12 (51 - 77)	40 - 50 (131 - 164)	30 - 40 (4.4 - 5.8)	EG34D - EG7099 - EG387 - EG9599 - EG8067
Heavy traction				
Old motors	10 - 12 (65 - 77)	< 45 (< 148)	< 35 (< 5)	EG34D
Modern motors	> 12 (> 77)	> 45 (> 148)	35 (5)	EG300H - EG9117 - EG387 - EG8067 EG7097 - EG6754 - EG8220
Diesel-electric traction (locomotives and electric trucks)				
Generators	10 - 14 (65 - 91)	40 (131)	25 (3.6)	EG389P - EG7099 - EG8067 - AC137
Alternators (excitation)	8 - 12 (51 - 77)	< 50 (< 164)	22 (3.2)	EG34D - EG389P - L1
Motors	15 (100)	45 (148)	35 (5)	EG7099 - EG8067 - EG7097 - EG6754 - EG8220
Fork lift truck and hoisting motors (low voltage)				
Open type (handling)	15 - 20 (100 - 130)	10 - 25 (33 - 82)	35 (5)	A121 - M621 - C7788
RECTIFIED CURRENT				
Heavy traction				
Modern motors	12 - 15 (77 - 100)	50 (164)	35 (5)	EG367 - EG300H - EG8067 - EG7097 - EG6754
ALTERNATING CURRENT				
16 ² / ₃ and 50 Hz heavy traction				
Motors	12 - 16 (77 - 104)	45 (148)	25 (3.6)	EG367 - E8067 - EG7097

Slip ring machines

TYPE OF CURRENT / APPLICATION	SLIP RING MATERIAL	CURRENT DENSITY A/cm ² (A/in ²)	SPEED m/s (ft/s)	PRESSION kPa (PSI)	BRUSH GRADES	
EARTH RETURN CURRENT UNITS (ERCU)						
All	Steel-Bronze	0 - 30 (0 - 194)	3 - 8 (10 - 26)	35 - 40 (5 - 5.8)	MC877 - MC79P	
DIRECT CURRENT						
Pickling / Tinning rolls	Bronze	20 - 30 (125 - 194)	3 (10)	18 - 40 (2.6 - 5.8)	MC79P - CG957	
Synchronous machines (grooved or plain slip rings)	3 000 rpm	Stainless steel	11 - 13 (62 - 85)	≤ 100 (≤ 328)	13 - 18 (1.9 - 2.6)	LFC554
		Steel	6 - 10 (39 - 65)	≤ 70 - 80 (≤ 230 - 262)	15 - 18 (2.2 - 2.6)	LFC501
	1 500 rpm	Steel-Bronze	8 - 12 (51 - 77)	≤ 40 (≤ 131)	18 (2.6)	CG651 - CG657 (BRONZE) EG34D - EG389P - L1 (ACIER)
	≤ 500 rpm	Cast iron	6 - 10 (39 - 65)	≤ 20 (≤ 66)	18 (2.6)	EG34D - EG389P - L1
Equalizers in hydrogen	Steel-Bronze	5 - 8 (33 - 52)	25 (82)	18 (2.6)	EG34D - EG9599 - M9426	
ALTERNATING CURRENT						
Asynchronous machines	Open type	Steel-Bronze	12 - 16 (78 - 104)	15 - 25 (49 - 82)	18 (2.6)	EG34D - EG389P - CG651 - CG607 - CG657 - CG677 - MC837
	Totally enclosed type	Steel-Cupro-nickel	6 - 8 (39 - 52)	15 - 25 (49 - 82)	18 (2.6)	EG34D
Motors with carbon brush lifting device	Steel-Bronze	25 - 30 (163 - 195)	20 - 25 (66 - 82)	18 (2.6)	MC79P - CG957	
High-speed asynchronous (pumps, ventilators)	Bronze	8 - 10 (52 - 65)	≤ 50 (≤ 164)	18 (2.6)	EG389P - EG34D - M9426	
Synchronous induction machines	Bronze	8 - 12 (51 - 77)	15 - 40 (49 - 131)	18 (2.6)	M673 - M9426	
Wind power generators	Steel-Carbon	12 - 15 (78 - 98)	45 (148)	18 (2.6)	M8295 - M9426 - CG626	

03

MAIN CARBON BRUSH TYPES, DIMENSIONS AND HARDWARE

“t”, “a” and “r” dimensions

When contacting us regarding your brush requirement, please provide the following:

- Dimensions in “t” x “a” x “r” (IEC norm 60136).
 - where “t” is the tangential dimension or “thickness”
 - “a” is the axial dimension or “width”
 - and “r” is the radial dimension or “length”.
- The “r” dimension may be for information only.
- The same rule applies whether this is a commutator or slip ring brush.
 - Be careful in specifying the unit of measurement as imperial and metric units may be easily confused (1” = 25.4 mm, is not the same as 25 mm).

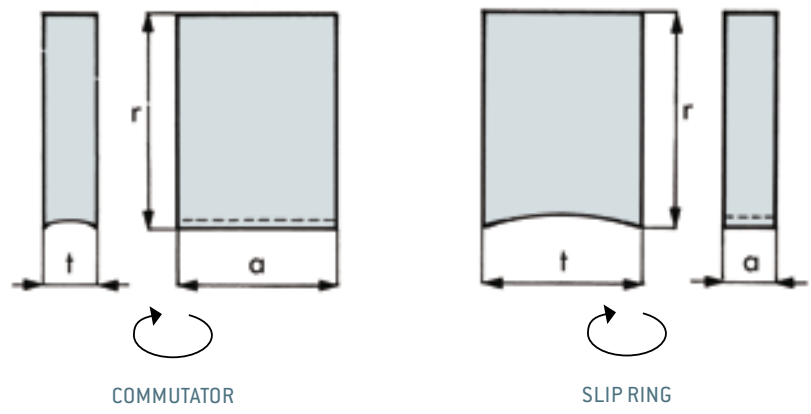

Orientation of a carbon brush on a commutator or on a slip ring

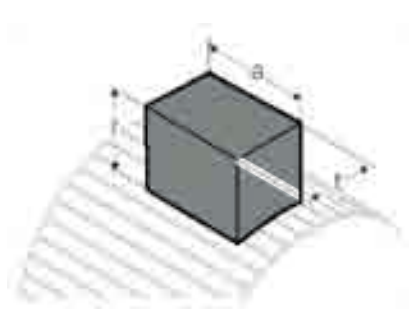

NORMAL ORIENTATION OF A CARBON BRUSH ON A COMMUTATOR

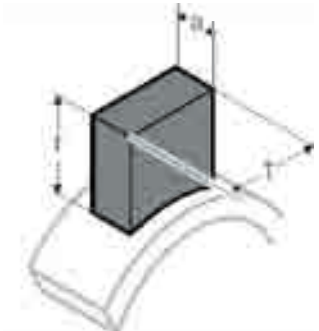

NORMAL ORIENTATION OF A CARBON BRUSH ON A SLIP RING

TYPES OF HARDWARE

Standard brush configurations

CARBON BRUSH TOPS (COMMON SHAPES)

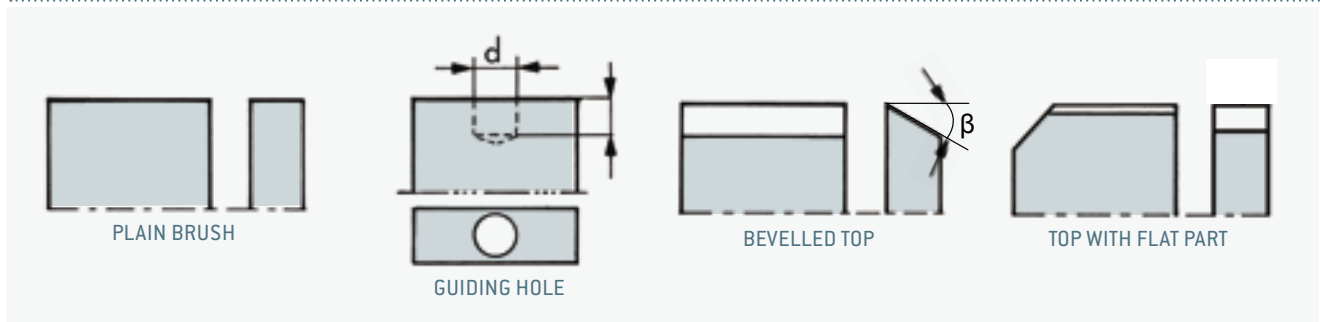

CARBON BRUSH SIDE EDGES

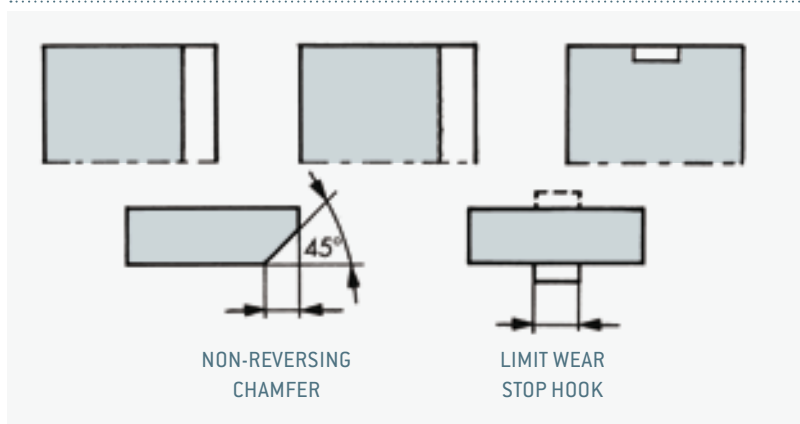

CONCAVE / CONVEX TOP

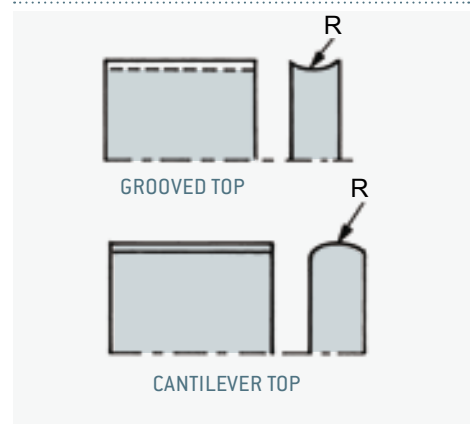

CARBON BRUSH CONTACT SURFACE

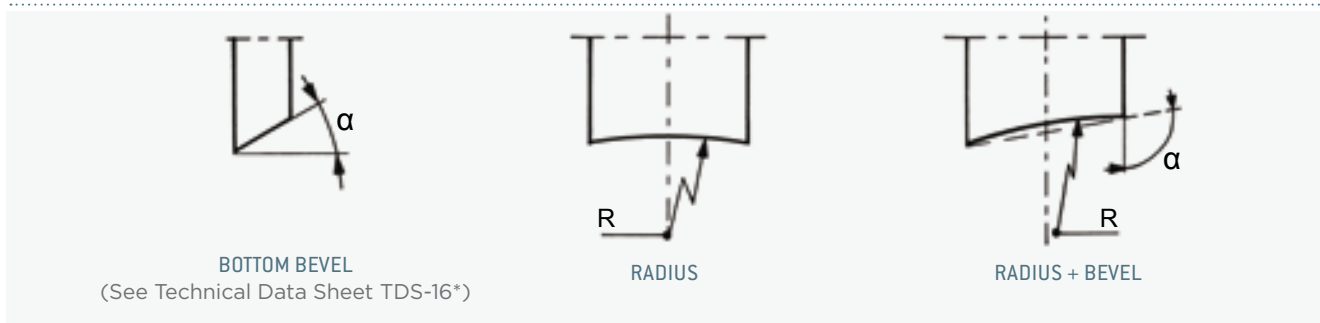

TERMINAL TYPES AND DIMENSIONS

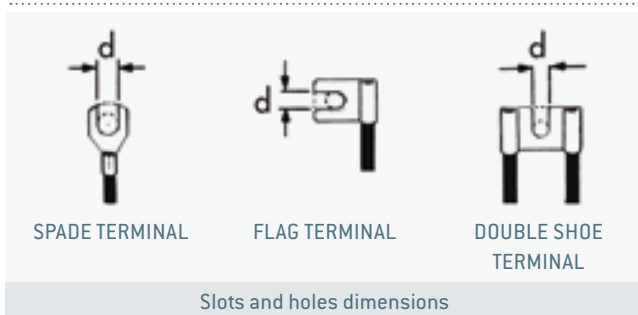

Slots and holes dimensions						
bolt ϕ (mm)	3	4	5	6	8	10
d (mm)	3,4	4,3	5,2	6,5	8,5	10,5

SHUNT LENGTH

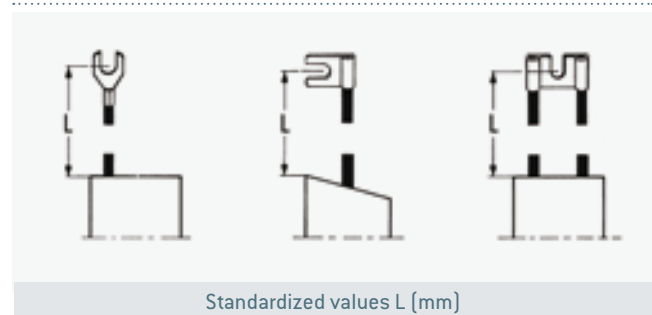

Standardized values L (mm)	
16 - 20 - 25 - 32 - 40 - 50 - 56 - 63 - 71	80 - 90 - 100 - 112 - 125 - 140 - 160

*More information can be obtained from our Technical data sheets, sent upon request, and also available from our web site www.mersen.com

Mounting methods

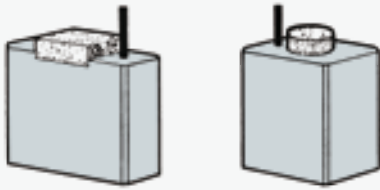

GLUED SHOCK ABSORBER

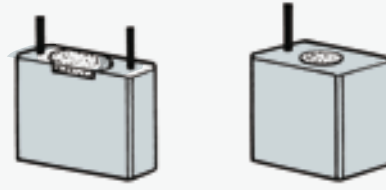

HARD INSULATING TOP
(RECESSED AND GLUED)

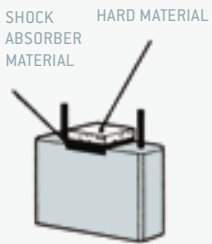

SHOCK ABSORBER
AND HARD MATERIAL
FIXED PLATE SILESS

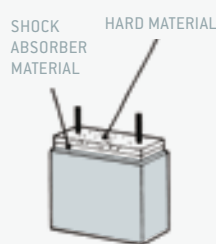

SHOCK ABSORBER
AND HARD PLATE
(THE TWO PLATES
ARE THREADED
ON TWO FLEXIBLES
AND NOT GLUED)



WEAR LIMITING
PLASTIC CLIPS

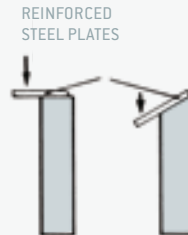

REINFORCED
STEEL PLATES

TOP PLATE
FOR CANTILEVER
PRESSURE DEVICE

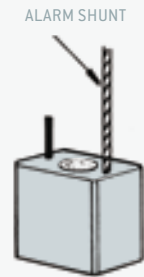

ALARM SHUNT

BRUSH WITH
ALARM SHUNT

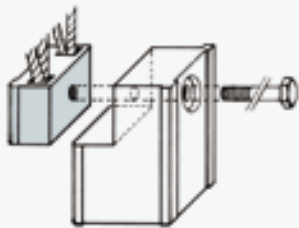

BRUSH WITH REMOVABLE TOP
FOR TINNING ROLLS

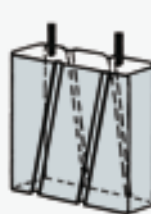

SINGLE BRUSHES

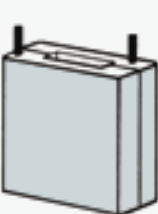
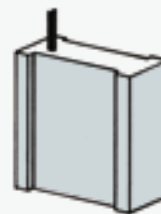

SPLIT BRUSH

DUST GROOVES AND RECESSES

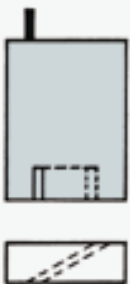

CONTACT FACE
WITH SAW CUT



CROSS GROOVED
CONTACT FACE

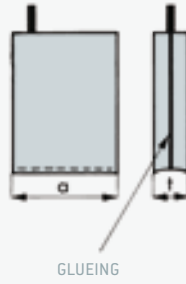

SANDWICH BRUSH*
(2 EG LAYERS)

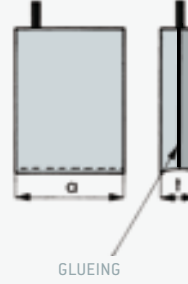

GLUED BRUSH*
1 EG LAYER
1 BG LAYER

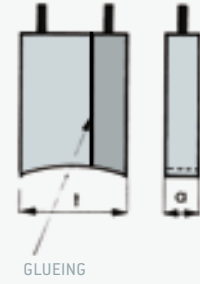

DUAL GRADE
COMPOSITE BRUSH
FOR SLIP RING*
1/3 EG LAYER
2/3 CG LAYER

*See Technical Data Sheet TDS-7, sent upon request, and also available from our web site www.mersen.com

Hardware for split brushes

GLUED RUBBER PAD

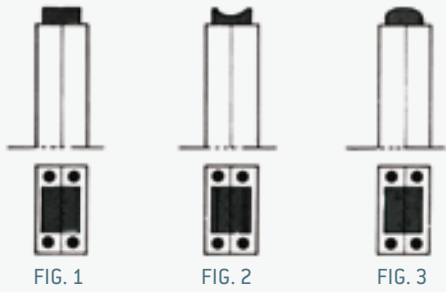

This pad is symmetrical, allowing bidirectional rotation. However, pressure is located at the contact point of the spring. Furthermore the high friction coefficient of the power pad keeps the spring from sliding freely on the brush top and creates lateral forces.

SHOCK ABSORBER PLATE AND HARD TOP PLATE

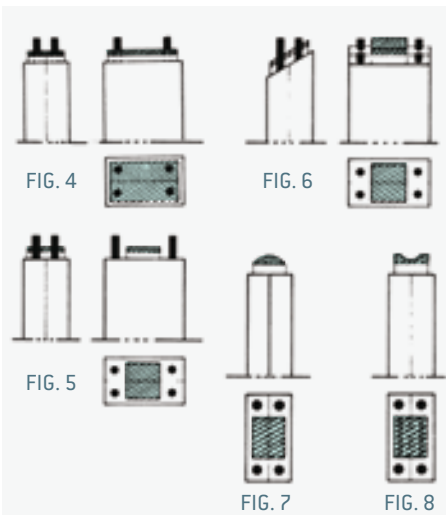

This is the most common mounting type. Placed directly on the carbon brush, the shock absorber plate is topped by a hard non-metallic plate. These two elements are kept in place by threading the shunts through them. They can either be independent (Fig. 4) or glued to each other and the carbon brush (Fig. 5 and 6). Depending on the shape of the spring, the hard top plate can be machined with a convex (Fig. 7) or concave profile (Fig. 8).



Shunts

Shunt diameters follow the industry standard as indicated below:

DIAMETER (mm)	1.6	1.8	2	2.2	2.5	2.8	3.2	3.6	4	4.5	5	5.6	6.3
NOMINAL VALUE OF CURRENT [A]	15	17	20	24	28	32	38	44	50	60	75	85	100

All shunts are available with tinned wires for corrosion protection.

MAIN SHUNT / CARBON BRUSH FASTENING METHODS

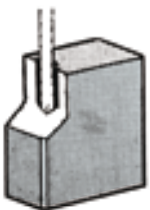

Tamping:

Conductive powder tamped mechanically into the hole around the shunt.

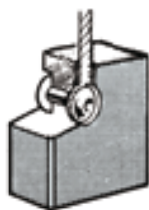

Riveting:

Process used for specific applications (e.g. aviation). The shunt loop placed into the carbon brush is preformed with a tool before the riveting operation.

04

RECOMMENDATIONS FOR INSTALLING CARBON BRUSHES IN MACHINES

22

Carbon brushes

Our recommendations are as follows:

- Do not mix different carbon brush grades on a machine to avoid serious problems.
- Make sure to remove the existing film before any carbon brush grade change.
- Check that the carbon brushes slide freely in their brush-holders without excess clearance (see Technical Data Sheet TDS-4*).
- Check that the carbon brushes were not fitted (or re-fitted) in the wrong direction in the brush-holders. This is especially crucial for carbon brushes with a bevelled contact surface or split brushes with a metal plate.

Carbon brush contact surface seating

To precisely match the carbon brush contact surface to the slip ring or commutator radius, use brush-seating stones (pumice stones) while running at low or no load. Seating stone dust rapidly erodes the brush contact surface to the right curvature. It is of course essential to use the "M" (Medium grain) grade of grinding stone again after this operation.

When a lot of carbon brush material has to be removed, first rough-grind the surface using 60 or 80-grit sandpaper. To do this, just insert it with the abrasive face up between the contact surface and the commutator, and move it back and forth as shown in Fig. 1. After brush seating thoroughly clean the contact surfaces, blowing away any abrasive material and/or carbon brush dust.

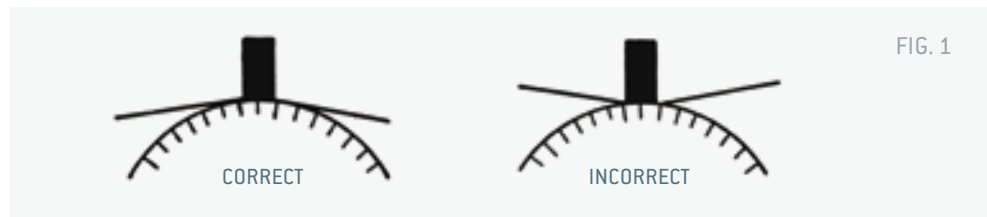

Brush-holders

- Make sure that the brush-holder is in working condition and check the interior surface condition.
- Adjust the "d" distance between brush-holder and commutator to range from 2.5 to 3 mm (Fig. 2).
- Align the carbon brushes parallel to the commutator bars.
- Check with an appropriate gauge that the pressures are equal on all the carbon brushes.

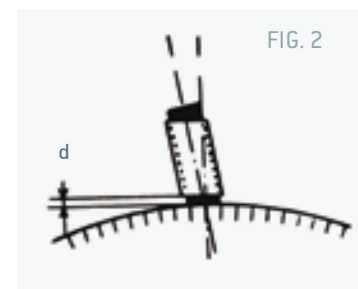

RECOMMENDED PRESSURES
IN NORMAL WORKING CONDITIONS

GRADE GROUPS	ON SLIP RING KPA (PSI)	ON COMMUTATOR	
		STATIONARY MACHINES KPA (PSI)	TRACTION MACHINES KPA (PSI)
ELECTROGRAPHITE	18 - 20 (2.6 - 2.9)	18 - 20 (2.6 - 2.9)	35 - 45 (5.1 - 6.5)
RESIN-IMPREGNATED ELECTROGRAPHITE		18 - 25 (2.6 - 3.6)	35 - 55 (5.1 - 8)
CARBOGRAPHITIC & RESIN-BONDED		18 - 20 (2.6 - 2.9)	N/A
SOFT GRAPHITE	11 - 20* (1.6 - 2.9)		
METAL-GRAPHITE	NORMAL SPEEDS	18 - 20 (2.6 - 2.9)	
	SPEEDS < 1 m/s	25 - 27 (3.6 - 3.9)	

* Please consult us

Note : 1 kPa = 10 cN/cm² = 0.145 PSI, and is close to 10 g/cm².

Commutators and slip rings

Check that there is no out-of-round above 3 mils (75 µm) or any obvious surface defect (**see Technical Data Sheet TDS-02***). If needed, grind or machine using a tool support frame. Mill or undercut the commutator slots (Fig. 1). Chamfer the bar edges 0.2 to 0.5 mm at 45° (Fig. 2). Clean the surface with an “M” grade of grinding stone. Avoid the use of abrasive paper or cloth. It is absolutely necessary to have sufficient roughness (1.3 to 2 µm Ra) in order to create and maintain a correct film.

Our experts are at your service for any on-site diagnostic, maintenance, or refurbishment.

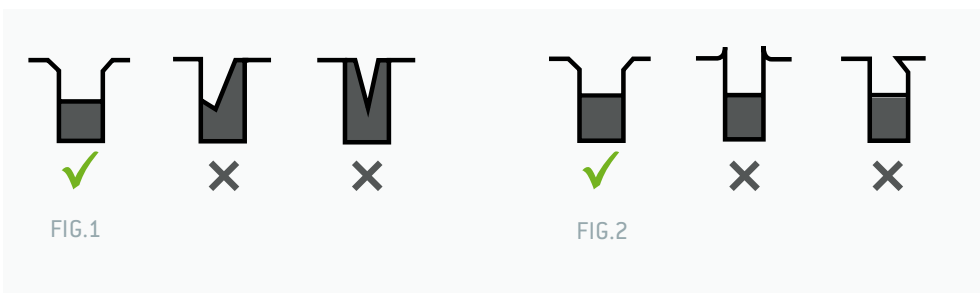

Putting the machine into service

First make sure that all carbon brushes slide freely inside the brush-holders, the shunts are correctly routed, and the terminals are properly tightened. Then start up the machine, preferably at low load, and increase progressively until full load is reached.

TECHNICAL DATA SHEET TDS-13

The film is a complex mix of metal oxides, carbon and water, which is deposited on the collector / slip ring. A close look at the film can help in assessing the condition of your electrical rotating machine.

Below are examples of various film conditions and commutator / slip ring faults, as well as their causes.

P. Film types

SUITABLE FILMS

COLOR INTENSITY

● P2 - P4 - P6: Normal films

- Uniform, light brown (P2) to darker brown (P6).
The machine and the carbon brushes work well.



P2



P4



P6

SUSPECT FILMING REQUIRING MONITORING

CLASSES OF FILM DEPOSIT

● P12: Streaky film

- Lines or bands of varying width, alternating light and dark, without copper wear
- Most frequent causes: excess humidity, oil vapors or aggressive gases in the atmosphere, underloaded carbon brushes.

● P14: Raw grooved film

(P14a: on commutator / P14b: on slip ring)

- Same as for P12, but with copper-colored raw grooved bands or very lightly colored bands. The metal is being attacked.
- Most frequent causes: same as for streaky film, but worsened or longer-lasting. Also the carbon brush grade may be unsuitable.

● P16: Patchy film

- Showing spots of various shapes, colors and dimensions, without any pattern.
- Most frequent causes: deformed or dirty commutator, out-of-round slip ring.



P12



P14a



P14b



P14c



P14FF*



P16a



P16b



P16FF*

*FF = Contact surface

PATCHINESS DUE TO MECHANICAL CAUSES

● P22: Uneven film, “screw thread” effect

- Most frequent cause: bad commutator machining during a maintenance operation (chattering tool).

● P24: Dark in patches, often followed by lighter faded patches, signs of commutator deformation

- Most frequent cause: defect affecting one bar or a group of bars, and making the carbon brush bounce. Light bars are high bars, dark bars are low bars.

● P26 - P28: Dark patches in the middle or on the edges

- Shading in the middle of the bars (P26) or at the two bar edges (P28).
- Most frequent cause: poor maintenance of the commutator.



P22



P24



P26



P28

BAR MARKING DUE TO ELECTRICAL CAUSES

● P42: Alternate bars of light and dark

- The dark bars have a polished, mat or blackened appearance. This pattern is repeated all around the whole commutator.
- The most frequent causes are of an electrical origin. They appear on armatures with more than one conductor per slot, and are linked with successive and increasingly difficult commutation of each successive conductor in the slot.

● P44: Pitting - Strong spark marks

- Most frequent cause: high frequency current flow.



P42



P44

PATCHES DUE TO POLLUTION

- **P62: Strong presence of deposits (oil, grease) on the film**

- Most frequent cause: carbon brush contaminated during maintenance operation, or environmental factors.



P62

B. Burning

- **B6: Spark burns at bar edges**

- **B8: Burning at center of bars**

- **B10: Pitted film**

- Variable number of small light patches randomly spread on a normal filmed track.
- Most frequent cause: sparking under the carbon brushes.



B6



B8



B10

T. Marking

PARTICULAR TYPES

- **T10: Brush image on commutator**

- **T11: Brush image on slip ring**

- Dark or black mark reproducing the carbon brush contact surface on the commutator / slip ring.
- Most frequent causes: accidental overload or electrolytic mark during a long period of stoppage.

- **T12: Dark fringe due to high bar L2**



T10



T11



T12

PARTICULAR TYPES (CONTINUATION)

- T14: Dark fringe due to low bar L4
- T16: Dark fringes due to high mica L6
- T18: Dark local patches due to burs L8



T14



T16



T18

L. Commutator bar faults

- L2: high bar
- L4: low bar
- L6: high mica
- L8: burs at bar edges
- L10: copper drag

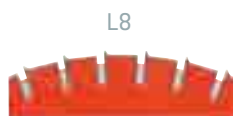
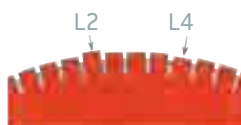

R. Commutator bar wear

- R2: Commutator with axial profile showing metal wear on each track - correct stagger. This wear may appear after a very long period of operation.
- R4: Commutator showing abnormal wear of the metal due to incorrect axial stagger, unsuitable carbon brush material, various pollutions...



R2



R4

Mersen's maintenance and service offerings

For any technical expertise, maintenance or training, Mersen experts offer their extensive knowledge, years of experience and global reach.

Expertise

- On-site practical support throughout the world
- Commutation expertise
- Measurements and diagnostics
- Support service on a daily basis
- Technical assistance by phone
- Technical documentation on-line on our website: www.mersen.com or upon request

Windtracker™ services

Mersen created the Windtracker™ Service in order to support wind farm operators. Windtracker™ experts, dedicated wind engineers and technicians, bring you up tower services, diagnostic capabilities, specific technical support and training, allowing you to optimize your wind turbine performance. They are supported by a large network of specialists in five continents, allowing Mersen to respond to your needs, wherever the location.

Training

Mersen provides training courses for maintenance of electric motors. For over twenty five years, more than 3,000 technicians have been undergone training, either at our facility or theirs.

Maintenance

- Diagnostics
- In situ commutator, slip ring and brush-holder refurbishment:
 - Surface re-conditioning
 - Mica undercutting (commutators)
 - Bar edge chamfering (commutators)
 - Helical groove edge chamfering (slip rings)
 - Out-of-round machining
 - Carbon brush pressure measurement
 - Proposal of suitable carbon brush grade
 - Redesign of the complete carbon brush, brush-holder and commutator / slip ring system
 - Installation of features to improve the performance of your machines (remote carbon brush wear monitoring, DustCollector dust extraction solutions...)
 - Retrofit solutions
- Support services on a daily basis

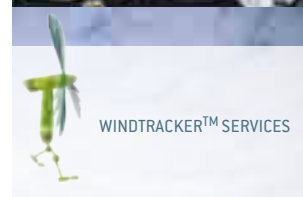

Mersen offers tools and accessories for carbon brush use and electrical rotating machine maintenance:

- **CL-Profiler:**
 - To measure commutator / slip ring profiles
 - Low speed inductive probe
 - Contact measurement
 - Ruby tip for “live” measurements
- **ComPro2000™:**
 - To measure commutator profiles during operation
 - Any speed, non-contact eddy-current transducer
- **DiaMeter**, for diameter measurement of commutators and slip ring assemblies prior to any possible machining
- **Electronic force gauges** for measuring brush-holder pressure systems
- **Stroboscopes** for slip ring, commutator and carbon brushes control on rotating machines
- **Roughness meters**
- **Commutation Indicator** (for spark intensity measurement)
- **Carbon brush wear indicator systems**
- **Tools** for maintenance of electrical rotating machine surfaces:
 - Grinding stones (abrasive cloth, brush seating stones)
 - Scrapers and slotting files
- **Mica undercutters**
- **Complete toolkit for maintenance of slip rings and commutators** (Please consult us):
 - 0-2.5 daN force gauge for measuring spring pressure
 - Battery-operated illuminated magnifier, for monitoring films and carbon brushes
 - Thickness gauges (11 blades) for measuring carbon brush / brush-holder clearance
 - 0-200 mm caliper for measuring carbon brush wear
 - Insulated probe for assessing carbon brush vibrations
 - Grinding stones
 - Abrasive cloth



Characteristics and identification

A carbon brush is clearly defined by four characteristics:

- The part number engraved on the brush or its grade (material and possible treatments)
- Its shape and main dimensions (see on page 18)
- Additional hardware type or attachment method (see on pages 19 to 21)
- The application and motor characteristics

The part number is the best way to identify a brush, but any additional information will help.

THERE ARE ALSO OTHER WAYS TO DEFINE A CARBON BRUSH:

DRAWING CATALOGUES

We can produce brush drawing catalogues containing the drawings and carbon brush model references used in our customers' plants. These catalogues make it easier for the maintenance people to identify and order spare carbon brushes. Each carbon brush is taken up by drawing and code number. To place an order you just have to quote the code mentioned in the drawing catalogue.

IDENTIFICATION BY THE BRUSH-HOLDER

If it is a Mersen brush-holder, you just have to mention its type, the " t x a " cage dimensions, and the carbon brush grade.

For modular brush-holders (MONG, MOSPI type), it is necessary to indicate the sheath height (N, B, H ou TH), which determines the carbon brush height.

The shunt length, which depends on the brush gear arrangement on the motor, also has to be mentioned, along with the terminal bolt diameter. For all other types, we need a carbon brush sample or a brush-holder drawing, as well as the motor type and characteristics.

CARBON BRUSH SAMPLE

A carbon brush sample, even worn out, will generally enable us to determine the main dimensions except the brush height, which has to be selected from the list issued by the I.E.C. according to the brush-holder, and given to us separately.

CARBON BRUSH DRAWING (OR SKETCH)

Excluding the requirements based on norms or Mersen manufacturing standards, there are few additional specifications required to make a carbon brush drawing.

Except in very specific cases, there is no need to specify:

- Tolerances on the main brush dimensions and on the shunt lengths
- Chamfer dimensions
- Type and thickness of materials used for attachments and connections
- Cross section and composition of shunts
- Shunt and terminal part fastening process
- Insertion depth of the shunts into the brushes
- Overall dimensions of the terminal parts

Delivery

We can supply most of the carbon brushes fitting any motor type within one week, or even one day under certain conditions.

CARBON BRUSH

APPLICATION DESCRIPTION FORM

(Text conforms with IEC norm 60136)

Company	<input type="text"/>	Surname / Name	<input type="text"/>
Adress	<input type="text"/>	Phone Nr	<input type="text"/> Fax Nr <input type="text"/>
Date	<input type="text"/>	Email	<input type="text"/>

Questions in grey-blue are essential information for us to determine the best brush grade appropriate to your machine.

INFORMATION CONCERNING THE MACHINE:

- Machine manufacturer:
 - Machine type:
 - Generator: AC DC - Moteur: AC DC
Direction of rotation: Reversible yes no
 - Converter: AC/DC DC/AC
- | | Nominal | In service
Normal | Max. |
|-------------------|---------|----------------------|------|
| 5• SPEED (rpm) | | | |
| 6• VOLTAGE (V) | | | |
| 7• CURRENT (Amps) | | | |
| 8• POWER (kW) | | | |
- Duty:
 - Duty cycle (including no load %):
 - Excitation: Shunt Separate Series Compound
 - Construction machine: Open Protected Closed
 - CARBON BRUSH MANUFACTURER AND GRADE:**
 - The slip rings are located: Between Outside the bearings
 - Are the slip rings in a closed enclosure? yes no

MACHINE'S ENVIRONMENT:

- Type of industry:
- Ambient temperature (°C / °F):
- Temperature in service (°C / °F):
- Relative humidity (%):
- Oil vapor:
- Corrosive gases - Type?
- Dust - Nature:
- Vibration?

OPERATING INFORMATION:

- Average brush life (hours):
- DESCRIPTION OF ANY PROBLEMS (IF ANY)**
.....
.....
.....

COMMUTATOR

- DIAMETER:**
- Nr of bars:
- Bar width:
- Micas width:
- NR OF TRACKS:**
- NR OF BRUSHES:**
- PER TRACK:**
- NR OF POLES:**
- BRUSH DIMENSIONS:**
(see Fig.1)
t = a = r =
- BRUSH BOTTOM ANGLE:**
(see Fig.3, 4 et 5)
 $\alpha = \dots\dots\dots^\circ$
- TOP BEVEL ANGLE:**
(see Fig.10 page 33)
 $\beta = \dots\dots\dots^\circ$
- SPLIT BRUSH?**
 Fig 6 Fig 7
 Fig 8 Fig 9
- The brushes on the same path are:
 In line Staggered

SLIP RINGS

- DIAMETER:**
- Width:
- NUMBER:**
- MATERIAL:**
- HELICAL GROOVE:**
 with without
Pitch:
- NR OF BRUSHES PER RING:**
.....
- BRUSH DIMENSIONS:**
(see Fig.2)
t = a = r =
- BRUSH BOTTOM ANGLE:**
(see Fig.3, 4 et 5)
 $\alpha = \dots\dots\dots^\circ$
- TOP BEVEL ANGLE:**
(see Fig.10)
 $\beta = \dots\dots\dots^\circ$
- Split brush?
 Fig 6 Fig 7
 Fig 8 Fig 9
- CURRENT PER RING:**A
 AC DC

26• COMMUTATOR'S SLIP RING'S CONDITION

- Good Glossy Matt
- Smooth Worn out Grooved
- Uniform Marked
- Marks: Evenly distributed Unevenly distributed Burnt
- Color: Light Average Dark

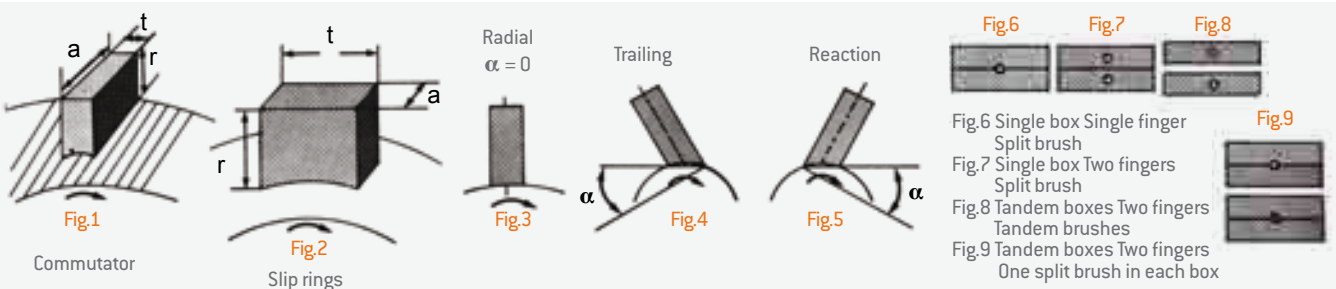

PLEASE FILL THIS FORM OUT TO HELP US FIND THE MOST SUITABLE CARBON BRUSH FOR YOUR SPECIFIC APPLICATION(S).

WHEN POSSIBLE PLEASE SEND US A SAMPLE OF THE CARBON BRUSH IN USE (even if worn) or a detailed sketch of the brush with its shunt and terminal (Use sketch Fig. 10 below as a guide).

DIMENSIONED MANUAL SKETCH OF THE BRUSH IN USE

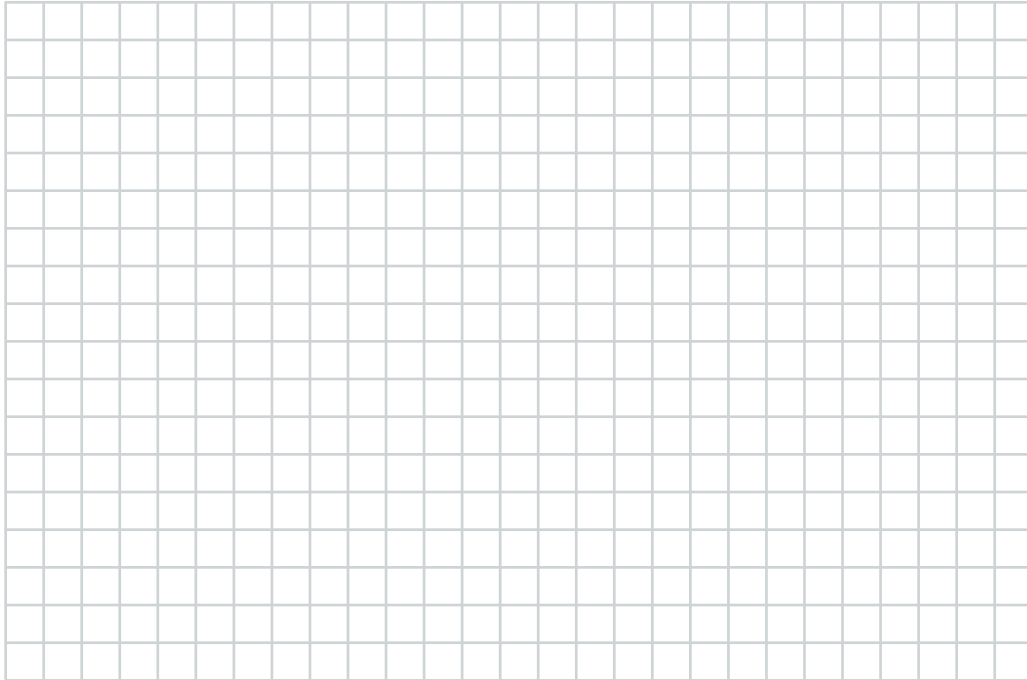

l SHUNT LENGTH
in mm

DIAMETER OR WIDTH
OF FIXING GAP in mm

ESSENTIAL INFORMATION FOR THE MANUFACTURE OF A CARBON BRUSH

Fixing gap width
or diameter in mm

If pressure clip
or insert required

β Top bevel angle
if present

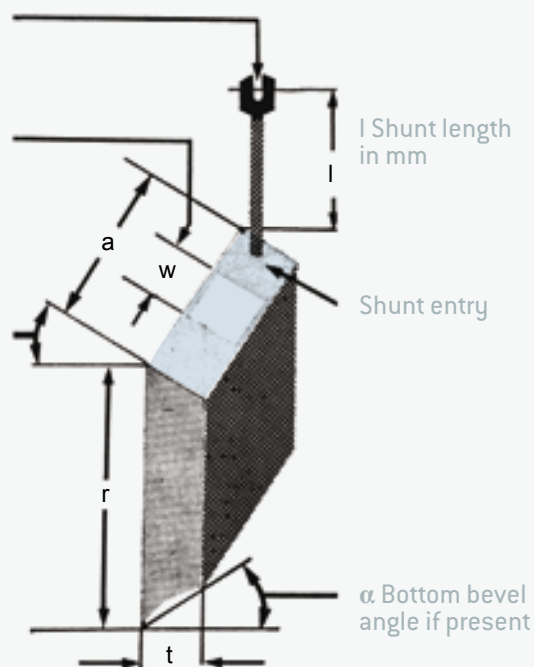

FIG.10

STANDARD SHAPES

SHAPES OF NEW TERMINALS (recommended)



SHAPES OF OLD TERMINALS

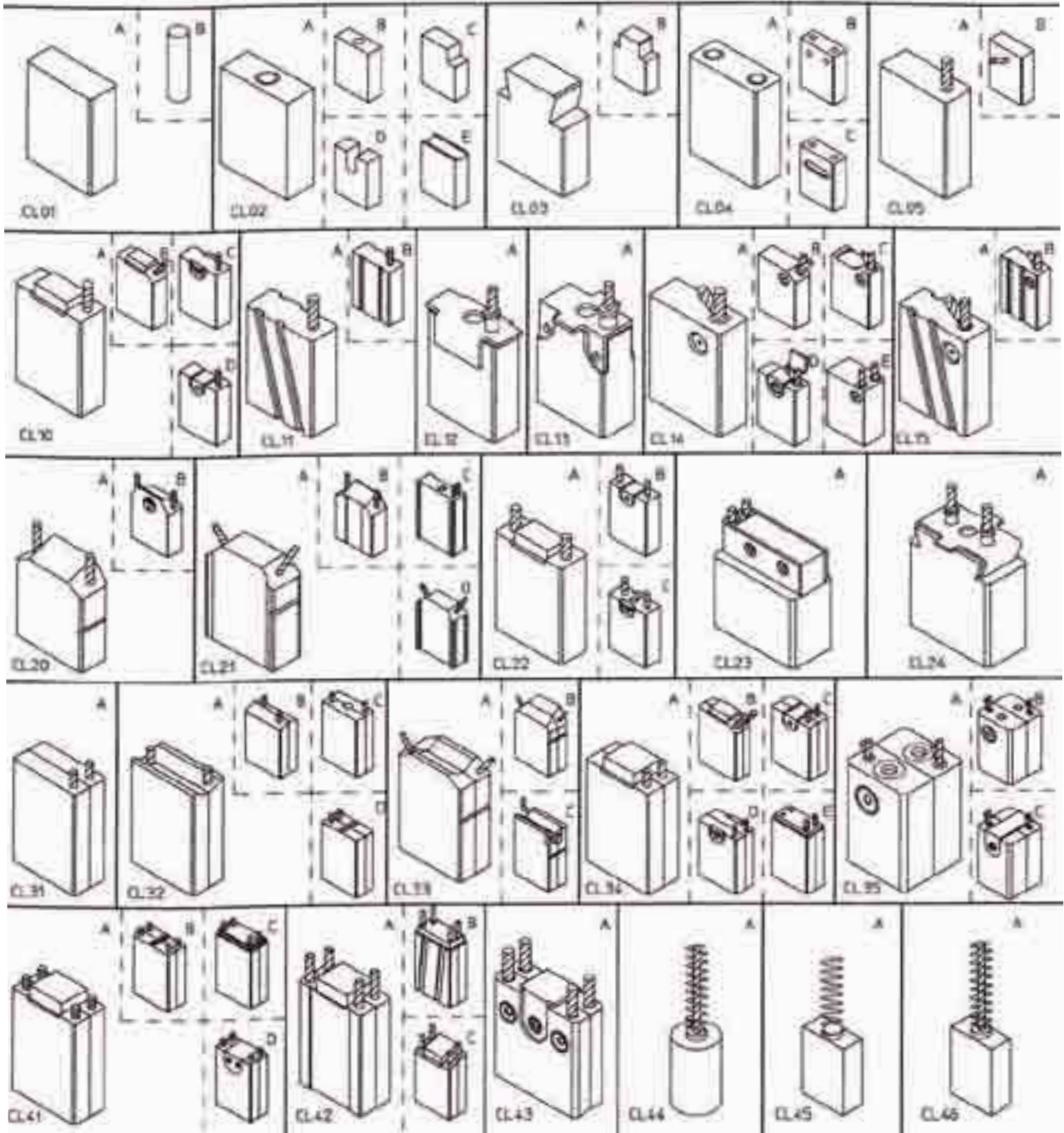
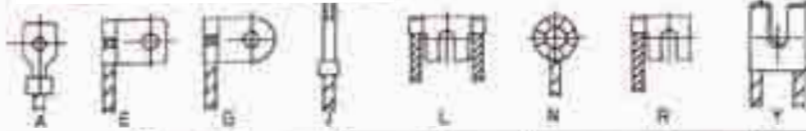

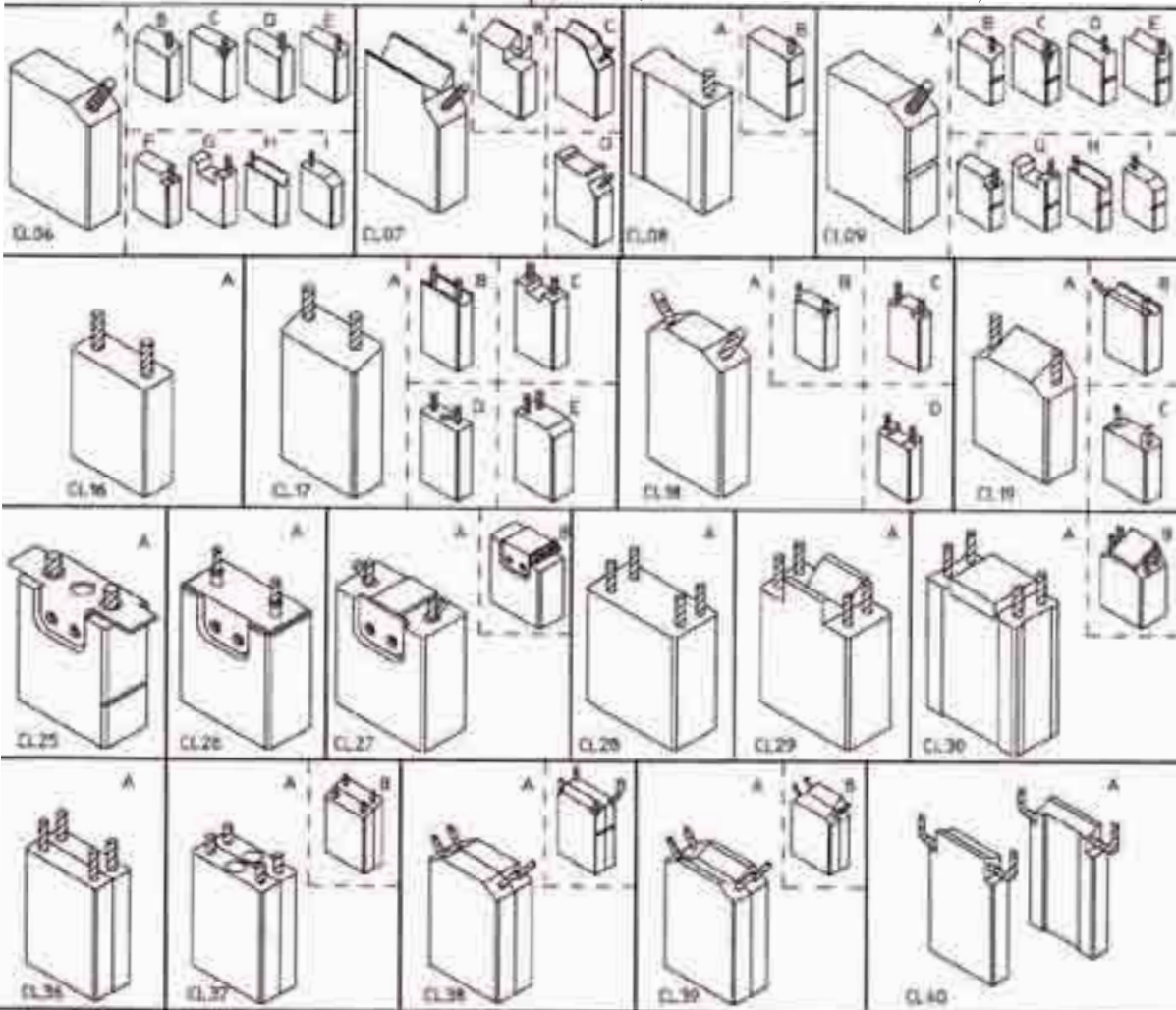
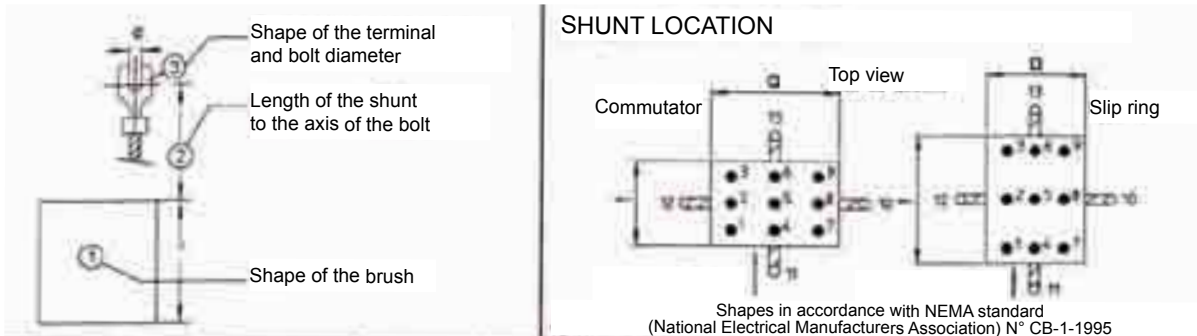

Special shapes	SANDWICH	The drawings represent 1 shape per box	
	Shape above with a "S" suffix	For example	
	Be careful: the number of wafers is multiplied by 2	Brush Pair 2 boxes = 2 shapes	Split brush 1 box = 1 shape
CL.47			

QUESTIONNAIRE FOR THE CHOICE OF A BRUSH-HOLDER PRESSURE SYSTEM

Company	<input type="text"/>	Surname / Name	<input type="text"/>
Address	<input type="text"/>	Phone Nr	<input type="text"/> Fax Nr <input type="text"/>
Date	<input type="text"/>	Email	<input type="text"/>

IDENTIFICATION OF THE SPRING AND SPRING CARRIERS FOR EUROPEAN MODELS

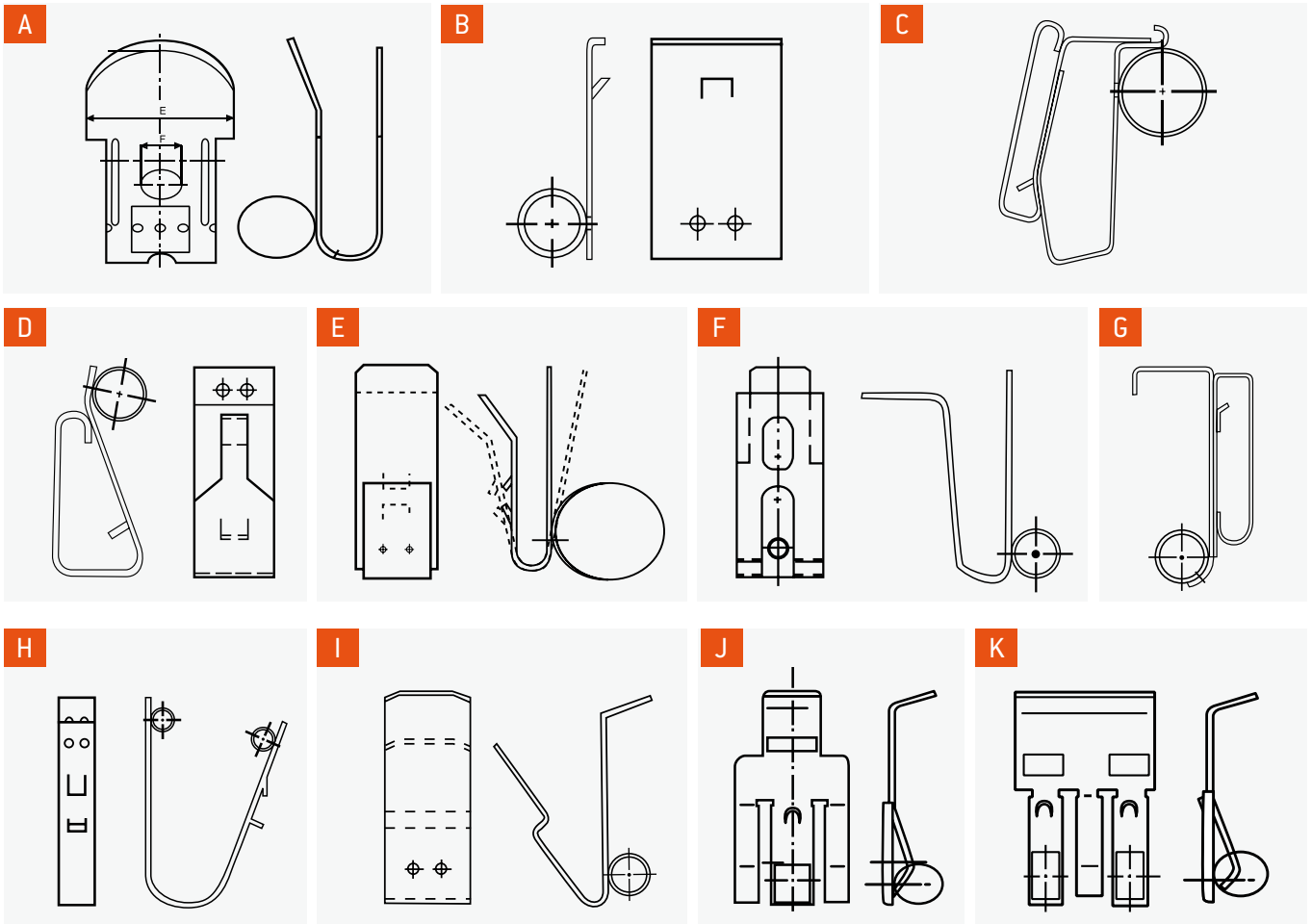

INDICATE THE LETTER CORRESPONDING TO YOUR NEED:

If the spring you need is not shown above, please provide a sketch on the reverse side of the form, showing front and side views or alternatively send us a sample. Minimum order quantity: 4 pieces.

DIMENSIONS AND CHARACTERISTICS

Brush size	t:mm	a:mm	r:mm
Spring	Diameter:mm	Width:mm	
Spring carrier	Width:mm	Height:mm	Thickness:mm
	Material:		Insulated:
Brush-holder	Width:.....mm	Length:mm	Dimension from bottom of holder to the mounting pin:.....mm

OTHER INFORMATION

Carrier engraving:	Quantity:	Delivery with brushes <input type="checkbox"/> Yes <input type="checkbox"/> No
--------------------------	-----------------	--------------------------------------------------------------------------------

OCCURRENCE OF TECHNICAL TERMS IN THIS GUIDE

• Apparent density.....	14, 15
• Bakelite graphite or resin-bonded carbon brush (grade).....	11, 15
• Bar edge chamfering.....	3, 29
• Carbographitic (grade).....	10, 14, 23
• Carbon brush bedding / seating.....	22
• Carbon brush guiding / Brush-holders.....	4, 22
• Carbon brush position.....	18, 31
• Carbon brush pressure.....	4, 5, 6, 13, 16, 22, 23, 29, 30
• Commutation, commuting.....	3, 5, 6, 11, 26, 29
• Contact surface.....	6, 7, 19, 22
• Corrosive vapors or gases.....	7, 25
• Current density.....	6, 9, 10, 11, 12, 13, 16, 17
• Current distribution.....	4, 5, 6
• Dual grade (composite) carbon brush.....	5, 20
• Dust.....	6, 7, 8, 29
• Electrographitic (grade).....	9, 14, 23
• Flexural strength.....	14, 15
• “ μ ” friction coefficient / Friction.....	4, 6, 7
• Humidity.....	5, 6, 7, 25
• Impregnation.....	9, 12
• Maximal load, underload, overload.....	4, 6, 25, 27
• Metal content (grade).....	12, 15
• Metal-graphite carbon brush (grade).....	12, 15, 23
• Mica, mica undercutting.....	3, 23, 28, 29, 30
• Multi wafer carbon brush.....	5, 20
• Oils and hydrocarbons.....	7, 25, 27
• Out-of-round, run out, deformation.....	3, 4, 23, 25, 29
• (Peripheral) speed.....	4, 5, 9, 10, 11, 12, 13, 14, 15, 16, 17, 23
• Resistivity.....	6, 14, 15
• Sandwich carbon brush.....	5, 6, 20
• Shore hardness.....	14, 15
• Skin, film.....	5, 6, 7, 22, 23, 24, 25, 26, 27, 30
• Soft graphite carbon brush (grade).....	10, 15, 23
• Staggering carbon brushes.....	5
• Surface condition / Roughness.....	3, 4, 22, 23, 29
• “t”, “a”, “r” dimensions.....	18
• Temperature.....	5, 9, 11, 12, 13
• Voltage drop / Contact drop.....	5
• Vibration.....	4, 5, 10, 30



LIST OF MERSEN'S TECHNICAL DATA SHEETS

(also available from WWW.MERSEN.COM)

OTHER DOCUMENTS RELATED TO MERSEN'S RANGE OF SOLUTIONS CAN BE SUPPLIED UPON REQUEST. DO NOT HESITATE TO CONTACT US.

TDS-01	Functions of a good carbon brush, what you should know	TDS-13	Aspects of commutator / slip ring skins
TDS-02	Condition of the surface of commutators and slip rings - Roughness	TDS-14	Brush sparking
TDS-03	Chamfering of commutator bar edges Machining of ring helical grooves	TDS-15	Brush wear
TDS-04	Brush and brush-holder tolerances on "t" and "a" dimensions	TDS-16	Standardization of carbon brush dimensions
TDS-05	Losses in carbon brushes	TDS-17	Air humidity
TDS-06	Setting the neutral at rest	TDS-18	Degreasing of commutators and rings
TDS-07	Sandwich brushes - Composite brushes	TDS-19	Brush seating
TDS-08	Preventive maintenance	TDS-20	Slip ring brushes
TDS-09	Circumferential brush stagger	TDS-21	Copper bridging of commutator bars (copper dragging)
TDS-10	Threading on slip rings	TDS-22	Ghost marking on synchronous machines slip rings (ghosting)
TDS-11	Brush spring pressure	TDS-23	Silicones
TDS-12	Ventilation	TDS-24	Dust arising from brush wear
		TDS-25	Underloaded machines

MERSEN IS A GLOBAL EXPERT IN ELECTRICAL POWER AND ADVANCED MATERIALS.

OUR MARKETS:

Energy: • Wind • Hydro • Photovoltaic • Nuclear Power • Conventional Thermal Power • Oil & Gas

Transportation: • Railways • Urban networks • Aerospace & Aeronautics • Ports & Marine • Electrical Vehicles

Electronics: • Polysilicon • Power Electronics • Semiconductors • Compound Semiconductors • Optical Fiber Production

Chemicals & Pharmaceuticals: • Organic Chemicals • Inorganic Chemicals • Fine Chemicals & Pharmaceuticals

Process industries: • Metallurgy • Mining • Oil & Gas • Cement • Pulp & Paper • Rubber & Plastic

• Water & Wastewater Treatment • Assembly Manufacturing • Mould Industry • Glass Industry • Sintering

• Furnace Industry

Other Markets: • Commercial • Residential • Data Communication • Elevators • Forklifts



GLOBAL EXPERT IN ELECTRICAL
POWER AND ADVANCED MATERIALS

EUROPE

FRANCE

Mersen France Amiens SAS
10, avenue Roger Dumoulin
80084 Amiens
France
Tel.: +33 3 22 54 45 00
infos.amiens@mersen.com

ASIA

CHINA

Mersen Pudong Co., Ltd
No 2 Building, 72 Jinwen Road
Pudong New District, Shanghai
201323 P.R China
Tel.: 86 21 58106360
sales.pudong@mersen.com

INDIA

Mersen India Pvt. Ltd.
5 Bommasandra Industrial Area
Bangalore 560099,
Karnataka
India
Tel.: +91 80 3094 6121/24/25
sales.ptt.india@mersen.com

NORTH AMERICA

USA

Mersen USA Bn Corp.
400 Myrtle Avenue
Boonton NJ 07005
U.S.A.
Tel.: +1 973 334 07 00
contact.ptt.usa@mersen.com

CANADA

Mersen Canada Dn Ltd
225 Harwood Boulevard
Vaudreuil-Dorion, Quebec
J7V 1Y3
Canada
Tel.: +1 450 455 5728
contact.ptt.dorion@mersen.com

SOUTH AMERICA

BRAZIL

Mersen do Brasil Ltda.
Rua Anita Maria Botti
Pedroso, 3
13315-000 - Cabreuva - SP
Brazil
Tel.: +55 11 2348 2360
vendas.ptt.brasil@mersen.com

